

**ML193DFE SERIES UNITS**

ML193DFE series units are high-efficiency gas furnaces manufactured with Lennox DuralokPlus aluminized steel clamshell-type heat exchangers, with a stainless steel condensing coil. ML193DFE units are available in heating input capacities of 44,000 to 88,000 Btuh and cooling applications from 1.5 to 4 tons.

Refer to Engineering Handbook for proper sizing.

Units are factory equipped for use with natural gas. A kit is available for conversion to LPG operation. All ML193DFE units are equipped with a hot surface ignition system. The gas valve is redundant to assure safety shut-off as required by C.S.A.

The heat exchanger, burners and manifold assembly can be removed for inspection and service. The maintenance section gives a detailed description on how this is done.

The ML193DFE can be "twinning" with a second unit. See twinning kit 16W72 for information for two units to operate as one, in a shared duct system controlled by a single thermostat.

All specifications are subject to change. Procedures outlined in this manual are presented as a recommendation only and do not supersede or replace local or state codes.



<b>⚠ WARNING</b>	
	<b>Electric shock hazard. Can cause injury or death. Before attempting to perform any service or maintenance, turn the electrical power to unit OFF at disconnect switch(es). Unit may have multiple power supplies.</b>

<b>⚠ WARNING</b>	
<b>Improper installation, adjustment, alteration, service or maintenance can cause property damage, personal injury or loss of life. Installation and service must be performed by a licensed professional HVAC installer (or equivalent), service agency or the gas supplier.</b>	

<b>⚠ CAUTION</b>	
<b>As with any mechanical equipment, contact with sharp sheet metal edges can result in personal injury. Take care while handling this equipment and wear gloves and protective clothing.</b>	

Table of Contents

Specifications . . . . . 2

Optional Accessories . . . . . 3

Blower Performance Data . . . . . 4

I-Unit Components . . . . . 7

II Placement and Installation . . . . . 21

III-Start-Up . . . . . 40

IV-Heating System Service Checks . . . . . 41

V-Typical Operating Conditions . . . . . 45

VI-Maintenance . . . . . 46

VII-Wiring and Sequence of Operation . . . . . 49

## SPECIFICATIONS

		Model No.	ML196DF045XE36B	ML196DF070XE48B	ML196DF090XE48C	ML196DF110XE60C
<b>Gas Heating Performance</b>	<sup>1</sup> AFUE		96%	96%	96%	96%
	Input - Btuh		44,000	66,000	88,000	110,000
	Output - Btuh		42,000	64,000	86,000	108,000
	Temperature rise range - °F		30 - 60	35 - 65	50 - 80	40 - 70
	Gas Manifold Pressure (in. w.g.) Nat. Gas / LPG/Propane		3.5 / 10	3.5 / 10	3.5 / 10	3.5 / 10
	High static - in. w.g.		0.5	0.5	0.5	0.5
<b>Energy Star® Certified</b>			Yes	Yes	Yes	Yes
<b>Connections in.</b>	Intake / Exhaust Pipe (PVC)		2 / 2	2 / 2	2 / 2	2 / 2
	Gas pipe size IPS		1/2	1/2	1/2	1/2
	Condensate Drain Trap (PVC pipe) - i.d.		3/4	3/4	3/4	3/4
	with furnished 90° street elbow		3/4 slip x 3/4 Mipt	3/4 slip x 3/4 Mipt	3/4 slip x 3/4 Mipt	3/4 slip x 3/4 Mipt
	with field supplied (PVC coupling) - o.d.		3/4 slip x 3/4 MPT	3/4 slip x 3/4 MPT	3/4 slip x 3/4 MPT	3/4 slip x 3/4 MPT
<b>Indoor Blower</b>	Wheel nom. diameter x width - in.		10 x 8	11-1/2 x 10	10 x 10	11 x 11
	Motor Type		DC Brushless	DC Brushless	DC Brushless	DC Brushless
	Motor output - hp		1/2	3/4	3/4	1
	Tons of add-on cooling		1.5 - 3	2 - 4	2 - 4	3 - 5
	Air Volume Range - cfm		505 - 1455	525 - 1720	860 - 1760	1010 - 3115
<b>Electrical Data</b>	Voltage		120 volts - 60 hertz - 1 phase			
	Blower motor full load amps		6.8	8.4	8.4	10.9
	Maximum overcurrent protection		15	15	15	15
<b>Shipping Data</b>	lbs. - 1 package		126	139	154	162

NOTE - Filters and provisions for mounting are not furnished and must be field provided.

<sup>1</sup> Annual Fuel Utilization Efficiency based on DOE test procedures and according to FTC labeling regulations. Isolated combustion system rating for non-weatherized furnaces.

## OPTIONAL ACCESSORIES

		"B" Width Models	"C" Width Models		
<b>CABINET ACCESSORIES</b>					
<b>Downflow Combustible Flooring Base</b>		<b>11M60</b>	<b>11M61</b>		
<b>CONDENSATE DRAIN KITS</b>					
<b>Condensate Drain Heat Cable</b>	6 ft.	<b>26K68</b>	<b>26K68</b>		
	24 ft.	<b>26K69</b>	<b>26K69</b>		
<b>Crawl Space Vent Drain Kit</b>	US	<b>51W18</b>	<b>51W18</b>		
	Canada	<b>15Z70</b>	<b>15Z70</b>		
<b>CONTROLS</b>					
<b>M30 Smart Wi-Fi Thermostat</b>		<b>15Z69</b>	<b>15Z69</b>		
<b>Remote Outdoor Temperature Sensor</b>		<b>X2658</b>	<b>X2658</b>		
<b>Furnace Twinning Panel</b>		<b>Y3653</b>	<b>Y3653</b>		
<b>Furnace Twinning Kit</b>		<b>16W72</b>	<b>16W72</b>		
<b>Blower Relay Kit (for two-stage outdoor units)</b>		<b>85W66</b>	<b>85W66</b>		
<b>DOWNFLOW FILTER KITS</b>					
<b><sup>1</sup> Downflow Filter Cabinet</b>		<b>51W07</b>	<b>51W08</b>		
	No. and Size of filter - in.	(2) 16 x 20 x 1	(2) 16 x 20 x 1		
<b>NIGHT SERVICE KIT</b>					
<b>Night Service Kit</b>		<b>84W48</b>	<b>84W48</b>		
<b>TERMINATION KITS</b>					
See Installation Instructions for specific venting information.					
<b>Direct Vent</b>	Concentric	US - 2 in.	<b>71M80</b>	<b>69M29</b>	
		3 in.	---	<b>60L46</b>	
		Canada - 2 in.	<b>44W92</b>	<b>44W92</b>	
		3 in.	---	<b>44W93</b>	
		Flush-Mount	US - 2, 2-1/2 or 3 in.	<b>51W11</b>	<b>51W11</b>
			Canada - 2, 2-1/2 or 3 in.	<b>51W12</b>	<b>51W12</b>
	Wall - Close Couple	US - 2 in.	<b>22G44</b>	---	
		3 in.	<b>44J40</b>	<b>44J40</b>	
	Wall - Close Couple WTK	Canada - 2 in.	<b>30G28</b>	---	
		3 in.	<b>81J20</b>	<b>81J20</b>	
	Roof Termination Flashing Kit (no vent pipe - 2 flashings)	2 in.	<b>15F75</b>	<b>15F75</b>	
		3 in.	<b>44J41</b>	<b>44J41</b>	
<b>VENTING</b>					
<b>Flue Coupling</b>	2 in.	<b>17H92</b>	<b>17H92</b>		

<sup>1</sup> Cleanable polyurethane frame type filter.

NOTE - Termination Kits (**44W92**, **44W93**, **30G28**, **51W12**, **81J20**) and Crawl Space Vent Drain Kit (**15Z70**) are certified to ULC S636 standard for use in Canada only.

**BLOWER DATA**

**ML193DF045XE36B PERFORMANCE (Less Filter)**

External Static Pressure in. w.g.	Air Volume / Watts at Various Blower Speeds									
	High (Black)		Medium-High (Brown)		Medium (Blue)		Medium-Low (Yellow)		Low (Red)	
	cfm	Watts	cfm	Watts	cfm	Watts	cfm	Watts	cfm	Watts
0.00	1436	316	1304	251	1173	186	944	104	786	69
0.10	1401	330	1275	261	1139	193	904	111	741	74
0.20	1366	344	1246	271	1105	200	864	118	696	79
0.30	1343	350	1218	278	1064	206	821	123	647	84
0.40	1311	358	1186	286	1034	214	780	127	598	87
0.50	1278	369	1160	293	998	220	736	133	544	93
0.60	1255	372	1124	301	968	228	692	138	495	97
0.70	1223	384	1095	308	931	233	646	143	442	102
0.80	1202	395	1059	312	896	239	605	149	395	106
0.90	1133	372	1033	321	864	246	561	153	350	110
1.00	981	334	994	328	827	253	519	158	---	---

**ML193DF070XE36B PERFORMANCE (Less Filter)**

External Static Pressure in. w.g.	Air Volume / Watts at Various Blower Speeds									
	High (Black)		Medium-High (Brown)		Medium (Blue)		Medium-Low (Yellow)		Low (Red)	
	cfm	Watts	cfm	Watts	cfm	Watts	cfm	Watts	cfm	Watts
0.00	1430	313	1336	252	1188	181	949	102	804	68
0.10	1407	321	1295	257	1150	188	909	108	753	73
0.20	1384	329	1254	262	1112	195	869	114	702	78
0.30	1346	342	1235	273	1080	203	825	119	647	82
0.40	1314	355	1198	278	1037	209	778	124	600	86
0.50	1301	360	1175	284	1002	215	737	131	541	92
0.60	1264	365	1120	293	973	223	693	136	492	97
0.70	1235	375	1098	300	934	228	650	142	439	100
0.80	1210	385	1068	308	896	236	602	147	392	105
0.90	1173	392	1033	312	870	243	556	152	---	---
1.00	1066	350	1002	324	831	249	516	157	---	---

**BLOWER DATA****ML193DF090XE48C PERFORMANCE (Less Filter)**

External Static Pressure in. w.g.	Air Volume / Watts at Various Blower Speeds									
	High (Black)		Medium-High (Brown)		Medium (Blue)		Medium-Low (Yellow)		Low (Red)	
	cfm	Watts	cfm	Watts	cfm	Watts	cfm	Watts	cfm	Watts
0.00	1790	368	1585	264	1458	212	1347	181	1234	136
0.10	1741	384	1526	275	1400	221	1299	189	1174	145
0.20	1692	400	1467	286	1342	230	1251	197	1114	154
0.30	1665	413	1429	296	1287	238	1209	207	1066	163
0.40	1619	426	1393	307	1245	246	1150	215	1003	171
0.50	1562	434	1341	315	1198	255	1100	222	941	177
0.60	1531	444	1287	321	1150	261	1049	230	898	183
0.70	1495	456	1246	332	1102	271	1004	237	847	190
0.80	1441	462	1204	339	1052	278	948	242	789	196
0.90	1298	403	1163	348	1012	286	900	249	730	203
1.00	1120	308	1118	355	964	292	848	256	666	209

**ML193DF090XE48C PERFORMANCE (Less Filter)**

External Static Pressure in. w.g.	Air Volume / Watts at Various Blower Speeds									
	High (Black)		Medium-High (Brown)		Medium (Blue)		Medium-Low (Yellow)		Low (Red)	
	cfm	Watts	cfm	Watts	cfm	Watts	cfm	Watts	cfm	Watts
0.00	1790	368	1585	264	1458	212	1347	181	1234	136
0.10	1741	384	1526	275	1400	221	1299	189	1174	145
0.20	1692	400	1467	286	1342	230	1251	197	1114	154
0.30	1665	413	1429	296	1287	238	1209	207	1066	163
0.40	1619	426	1393	307	1245	246	1150	215	1003	171
0.50	1562	434	1341	315	1198	255	1100	222	941	177
0.60	1531	444	1287	321	1150	261	1049	230	898	183
0.70	1495	456	1246	332	1102	271	1004	237	847	190
0.80	1441	462	1204	339	1052	278	948	242	789	196
0.90	1298	403	1163	348	1012	286	900	249	730	203
1.00	1120	308	1118	355	964	292	848	256	666	209

# PARTS ARRANGEMENT

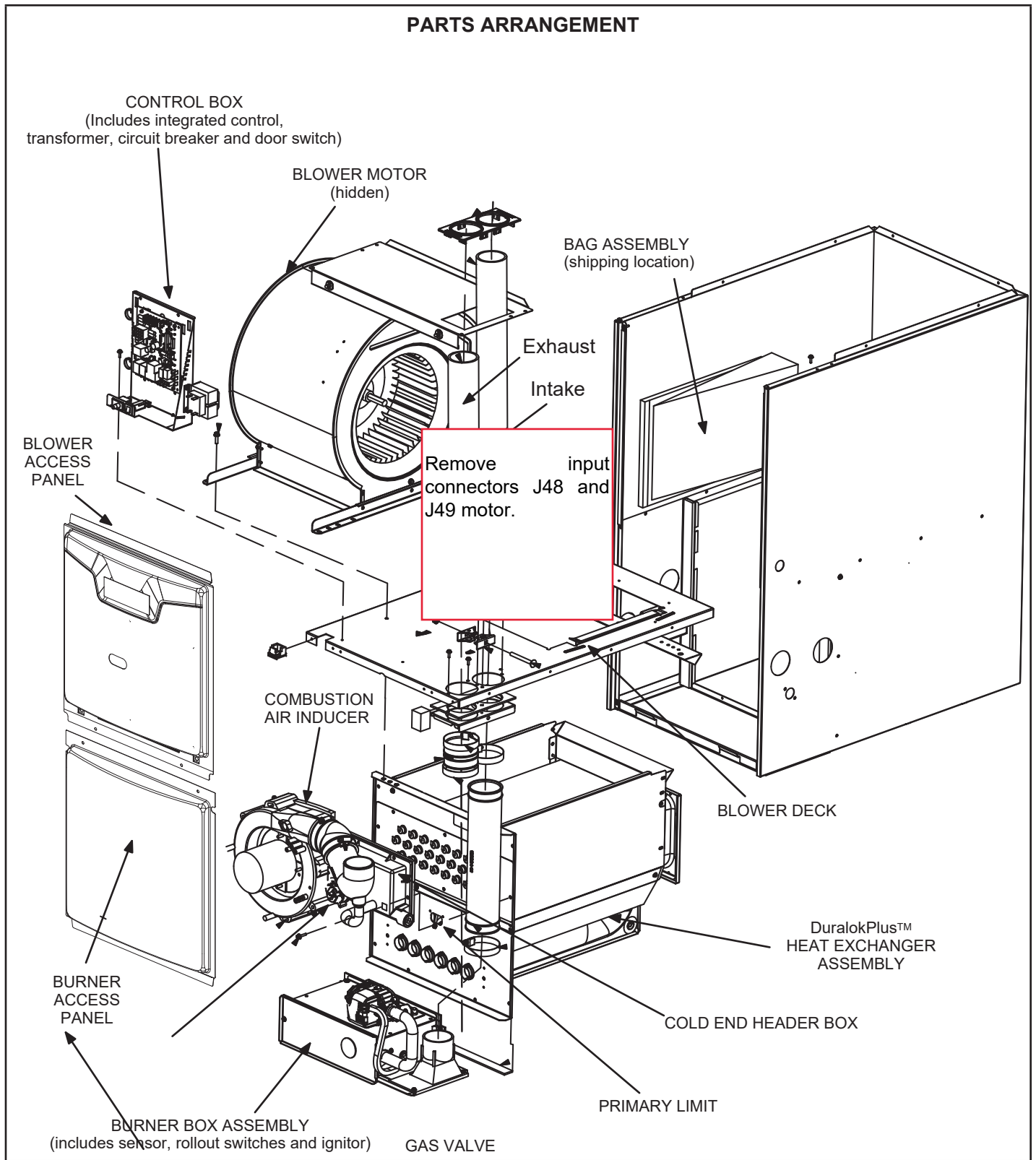

FIGURE 1

## I-UNIT COMPONENTS

### ELECTROSTATIC DISCHARGE (ESD) Precautions and Procedures



## CAUTION



**Electrostatic discharge can affect electronic components. Take precautions to neutralize electrostatic charge by touching your hand and tools to metal prior to handling the control.**

ML193DFE unit components are shown in FIGURE 1. The combustion air inducer, gas valve and burners can be accessed by removing the burner access panel. The blower and control box can be accessed by removing the blower access door.

#### A-Control Box Components (FIGURE 2)

Unit transformer (T1) and integrated ignition control (A92) are located in the control box. In addition, a door interlock switch (S51) is located in the control box.

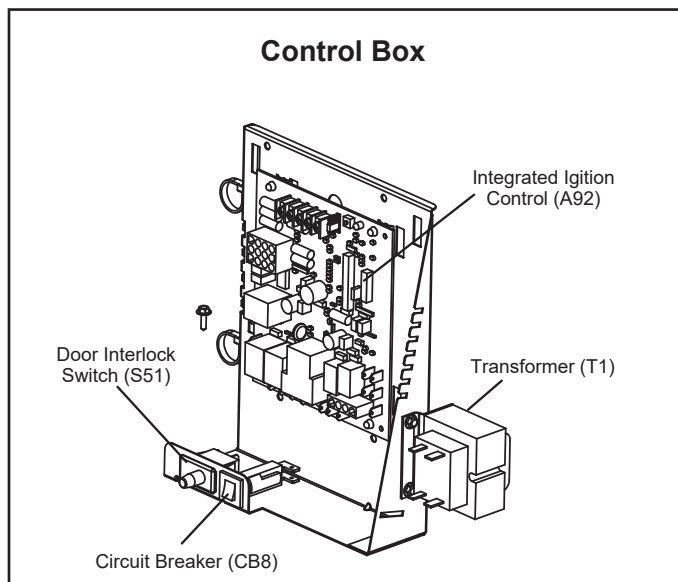

**FIGURE 2**

#### 1. Transformer (T1)

A transformer located in the control box provides power to the low voltage section of the unit. The transformers on all models are rated at 40VA with a 120V primary and 24V secondary.

#### 2. Door Interlock Switch (S51)

A door interlock switch rated 14A at 120VAC is located on the control box. The switch is wired in series with line voltage. When the blower door is removed the unit will shut down.

#### 3. Circuit Breaker (CB8)

A 24V circuit breaker is also located in the control box. The switch provides overcurrent protection to the transformer (T1). The breaker is rated at 3A at 32V. If the current exceeds this limit the breaker will trip and all unit operation will shutdown. The breaker can be manually reset by pressing the button on the face.

#### 4. Integrated Ignition Control (A92)

103217-03 & 107163-01



## WARNING

**Shock hazard.**

**Disconnect power before servicing. Control is not field repairable. If control is inoperable, simply replace entire control.**

**Can cause injury or death. Unsafe operation will result if repair is attempted.**

The hot surface ignition control system consisting of an integrated control (FIGURE 3 or FIGURE 5 with control terminal designations in TABLE 1, TABLE 2 and TABLE 3), sensor and ignitor (FIGURE 7). The integrated control and ignitor work in combination to ensure furnace ignition and ignitor durability. The integrated control, controls all major furnace operations. The integrated control also features a RED LED for troubleshooting and two accessory terminals rated at (1) one amp. The nitride ignitor is made from a non-porous, high strength proprietary ceramic material that provides long life and trouble free maintenance.

**TABLE 1**

4-Pin Terminal Designation	
PIN #	FUNCTION
1	Combustion Air Inducer Line
2	Ignitor Line
3	Combustion Air Inducer Neutral
4	Ignitor Neutral

**TABLE 2**

12-Pin Terminal Designations	
PIN #	FUNCTION
1	High Limit Output
2	IFC 103217-03 Not Used IFC 107163-01 Flame Sense
3	24V Line
4	Not Used
5	Rollout Switch Out
6	24V Neutral
7	High Limit Input
8	Ground
9	Gas Valve Common
10	Pressure Switch In
11	Rollout Switch In
12	Gas Valve Out

**TABLE 3**

<b>1/4" Quick Connect Terminals</b>	
120HUM	Humidifier 120VAC
LINE	120VAC
XFMR	Transformer 120VAC
CIRC	Indoor blower 120VAC
EAC	Indoor air quality accessory 120VAC
NEUTRALS	Common 120VAC
HUM24	Humidifier 24VAC
<b>3/16" Quick Connect Terminals</b>	
COOL	Cooling tap 24VAC
HEAT	Heating tap 24VAC
FAN	Continuous blower 24 VAC
PARK (no power)	Park terminal for speed taps
FS	Flame sense
24 COM	Common 24VAC

**TABLE 4**  
**Ignition Control 103217-03**

<b>RED LED Flash Code <sup>2</sup></b>	<b>Diagnostic Codes / Status of Furnace</b>
Off	No power to control or board fault detected
Heartbeat <sup>1</sup>	Normal Operation - Idle, Continuous Fan, Cool
Continuous Rapid Flash	Call For Heat / Burner Operation
1	Reverse Line Voltage Polarity
2	Improper Earth Ground
3	Burner failed to light, or lost flame during heat demand
4	Low Flame Signal - check flame sensor
5	Watchguard - burner failed to light, exceeded maximum number of retries or recycles.
6	Not Used
7	Primary or Secondary Limit Open or Watchguard Mode - Limit Switch Open longer than 3 minutes
8	Rollout Switch Open
9	Pressure Switch failed to close or opened during heat demand
10	Watchguard - Pressure Switch opened 5 times during one heat demand
11	Pressure Switch stuck closed prior to activation of combustion air inducer
12	Flame Sensed without gas valve energized
13	Low Line Voltage
<b>Notes</b>	
Note - 1	A "Heartbeat" is indicated by a "Slow Flash" - 1 sec on 1 sec off, repeating
Note - 2	Error codes are indicated by a "rapid flash" - the LED flashes X times at ½ second on ½ second off, remains off for 3 seconds then repeats.
Note - 3	Last 10 error codes are stored in memory including when power is shut off to the unit. - To recall, press and release button, most recent will be displayed first, LED off for 3 sec, then next error code is displayed, etc. To clear error codes, depress and hold button longer than 5 seconds.



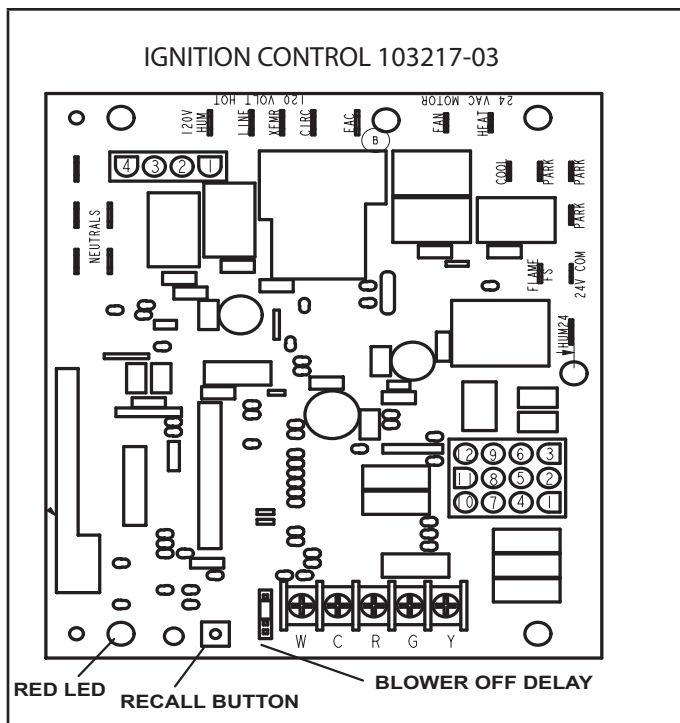

FIGURE 3

**Electronic Ignition (FIGURE 6)**

On a call for heat the integrated control monitors the combustion air inducer pressure switch. The control board will not begin the heating cycle if the pressure switch is closed (by-passed). Once the pressure switch is determined to be open, the combustion air inducer is energized. When the differential in the pressure switch is great enough, the pressure switch closes and a 15-second pre-purge begins. If the pressure switch is not proven within 2-1/2 minutes, the integrated control goes into Watchguard-Pressure Switch mode for a 5-minute re-set period.

After the 15-second pre-purge period, the ignitor warms up for 20 seconds during which the gas valve opens at 19 seconds for a 4-second trial for ignition. The ignitor remains energized for the first 3 seconds during the 4 second trial. If ignition is not proved during the 4-second period, the integrated control will try four more times with an inter-purge and warm-up time between trials of 35 seconds. After a total of five trials for ignition (including the initial trial), the integrated control goes into Watchguard-Flame Failure mode. After a 60-minute reset period, the integrated control will begin the ignition sequence again.

**Fan Time Control**

**Ignition Control 103217-03**

**Heating Fan On Time**

The fan on time of 30 seconds is not adjustable.

**Heating Fan Off Time**

Fan off time (time that the blower operates after the heat demand has been satisfied) can be adjusted by moving the jumper to a different setting. The unit is shipped with a factory fan off setting of 90 seconds. For customized comfort, monitor the supply air temperature once the heat demand is satisfied. Note the supply air temperature at the instant the blower is de-energized.

Adjust the fan-off delay to achieve a supply air temperature between 90° - 110° at the instant the blower is de-energized. (Longer delay times allow for lower air temperature, shorter delay times allow for higher air temperature). See FIGURE 4.

**Cooling Fan On Time**

The fan on time is 2 seconds and is not adjustable.

**Cooling Fan Off Time**

The control has a 45 second fan off delay after cooling demand has been met. This delay is factory set and not adjustable.

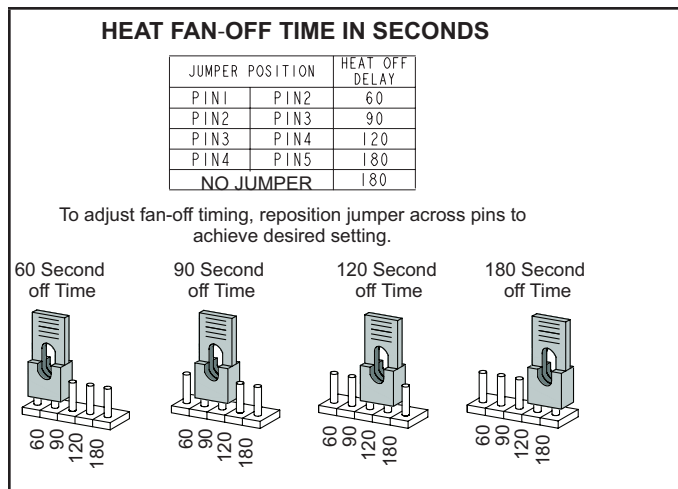
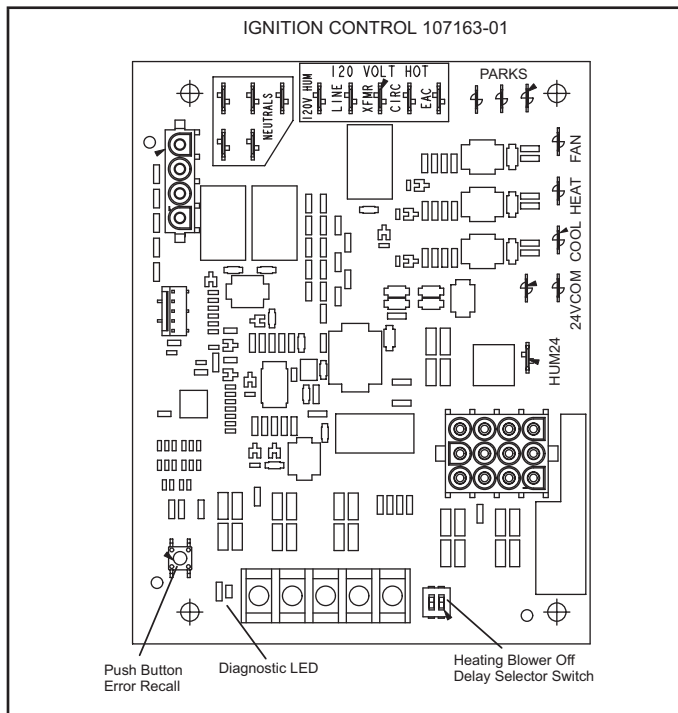

FIGURE 4

**TABLE 5**  
**Ignition Control 107163-01**

RED LED Flash Code	Diagnostic Codes / Status of Furnace
Off	No Power to Control or Board Fault Detected
On	Board Fault Detected
Fast Heartbeat <sup>3</sup>	Call for Heat / Burner Operation
Slow Heartbeat <sup>1</sup>	Normal Operation – Idle, Continuous Fan, or Cool
1 Flash <sup>2</sup>	Reverse Line Voltage Polarity or Phasing of 120V power
2 Flashes <sup>2</sup>	Improper earth ground
3 Flashes <sup>2</sup>	Burner failed to light, or lost flame during heat demand
4 Flashes <sup>2</sup>	Low flame signal – check flame sensor
5 Flashes <sup>2</sup>	Watchguard – burner failed to light, exceeded maximum number of retries/recycles, 1 hour lockout
6 Flashes <sup>2</sup>	Not used
7 Flashes <sup>2</sup>	Primary or Secondary limit switch open or Watchguard mode – Limit Switch open longer than 3 minutes
8 Flashes <sup>2</sup>	Roll-out Switch Open
9 Flashes <sup>2</sup>	Pressure Switch failed to close or opened during heat demand, inducer on
10 Flashes <sup>2</sup>	Watchguard - Pressure switch opened 5 times during a single heating demand
11 Flashes <sup>2</sup>	Pressure switch stuck closed prior to activation of Combustion Air Inducer
12 Flashes <sup>2</sup>	Flame sensed without gas valve energized
13 Flashes <sup>2</sup>	Low line voltage
Notes	
Note - 1	A slow heartbeat is indicated by 1s on / 1s off. It is used for idle, continuous fan and cool modes.
Note - 2	Error codes are indicated by a “rapid flash” - the LED flashes X times at ½ second on ½ second off, remains off for 3 seconds then repeats.
Note - 3	A fast heartbeat is indicated by 0.5s on / 0.5s off. It is only used during a heat call.
Note - 4	Last 10 error codes are stored in memory including when power is shut off to the unit. - To recall, press, and release button, most recent will be displayed first, LED off for 3 sec, then next error code is displayed, etc. To clear error codes, depress and hold button longer than 5 seconds.



**FIGURE 5**

**Fan Time Control**

**Ignition Control 107163-01**

The heat fan-on time of 30 seconds is not adjustable. The cool fan-on time of 2 seconds is not adjustable. The heat fan-off delay (amount of time that the blower operates after the heat demand has been satisfied) may be adjusted by changing the two position dip switch on the integrated control, to one of four selections. Blower off delay is factory set at 90 seconds. For other blower off delay settings, please refer to the following chart:

Blower Delay Select		
	SW2-1	SW2-2
60	OFF	ON
90	OFF	OFF
120	ON	OFF
180	ON	ON
Factory Setting is 90		

## B-Heating Components

Combustion air inducer (B6), primary limit control (S10), SureLight ignitor, burners, flame rollout switch (S47), gas valve (GV1), combustion air prove switch (S18), and clam-shell heat exchangers are located in the heating compartment. The heating compartment can be accessed by removing the burner access panel.

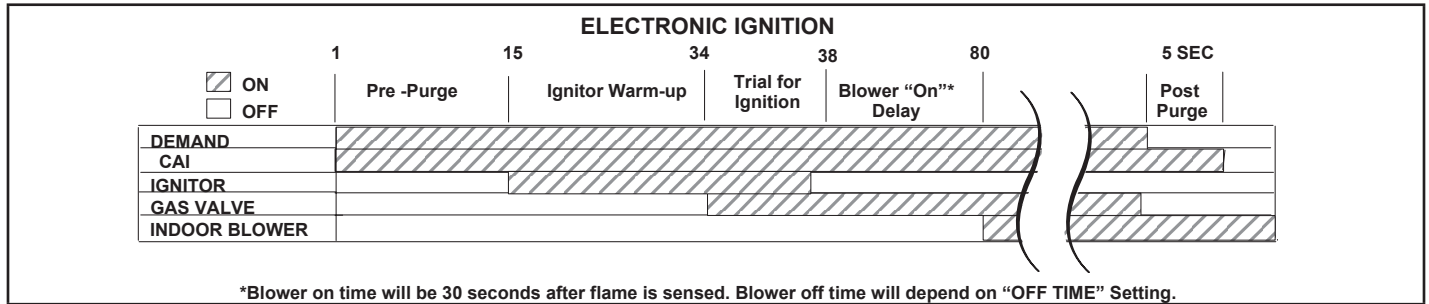

**FIGURE 6**

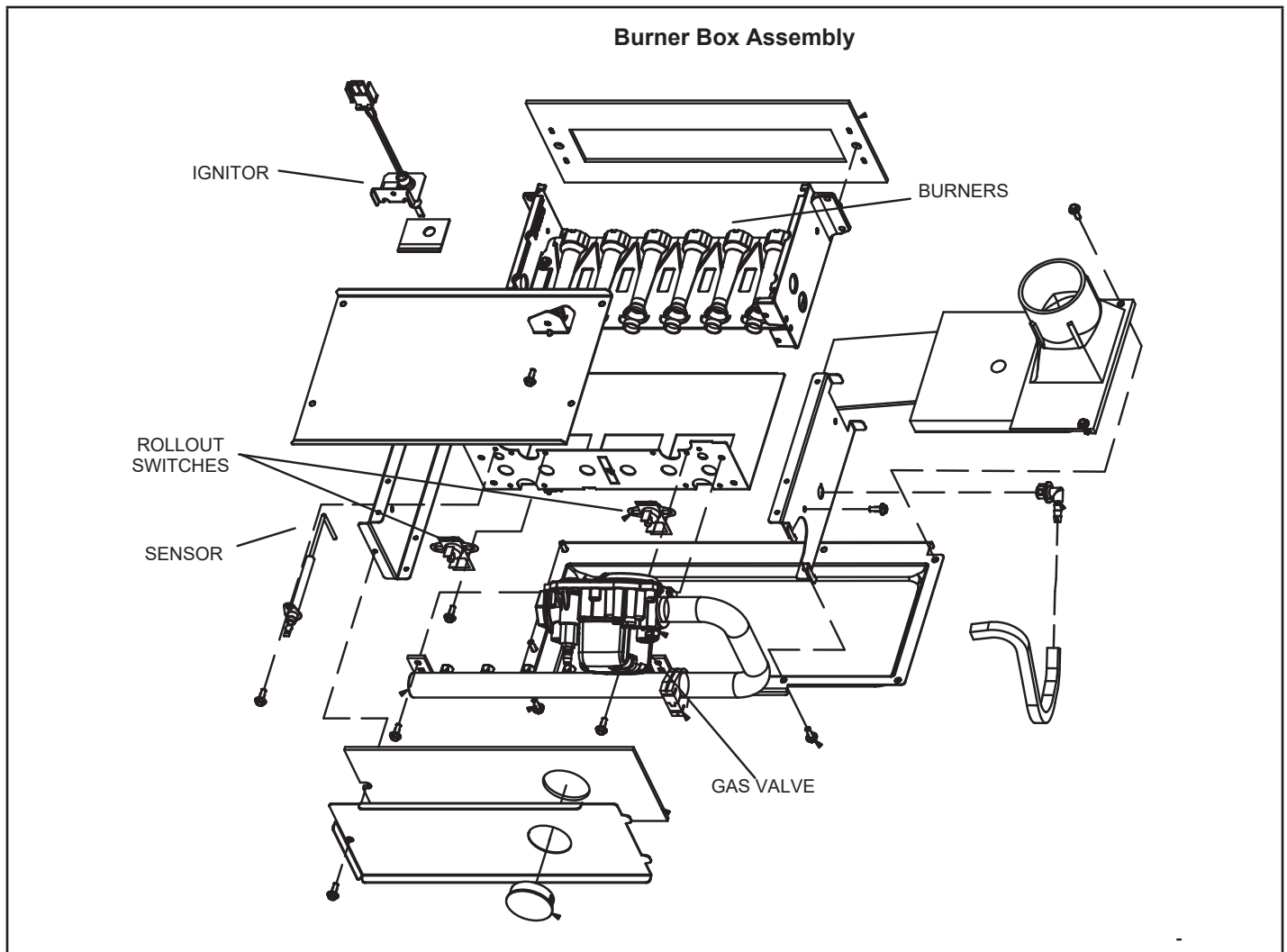

**FIGURE 7**

## 1. Flame Rollout Switches (FIGURE 7)

Flame rollout switches S47 are SPST N.C. high temperature limits located on the top left and bottom right of the front burner box plate. S47 is wired to the burner ignition control A92. When either of the switches sense flame rollout (indicating a blockage in the combustion passages), the flame rollout switch trips, and the ignition control immediately closes the gas valve. Switch S47 in all ML193DFE units is factory preset to open at 250F + 12F (121C + 6.7C) on a temperature rise. All flame rollout switches are manual reset.

## 2. Heat Exchanger (FIGURE 8)

ML193DFE units use an aluminized steel primary and stainless steel secondary heat exchanger assembly. Heat is transferred to the air stream from all surfaces of the heat exchanger. The shape of the heat exchanger ensures maximum efficiency.

The combustion air inducer pulls fresh air through the burner box. This air is mixed with gas in the burners. The gas / air mixture is then burned at the entrance of each clamshell. Combustion gases are then pulled through the primary and secondary heat exchangers and exhausted out the exhaust vent pipe.

## 3. Primary Limit Control (FIGURE 8)

Primary limit (S10) used on ML193DFE units is located in the heating vestibule panel. When excess heat is sensed in the heat exchanger, the limit will open. Once the limit opens, the furnace control energizes the supply air blower and de-energizes the gas valve. The limit automatically resets when unit temperature returns to normal. The switch is factory set and cannot be adjusted. For limit replacement remove wires from limit terminals and rotate limit switch 90 degrees. Slowly remove from the vestibule panel. Install replacement limit with same care.

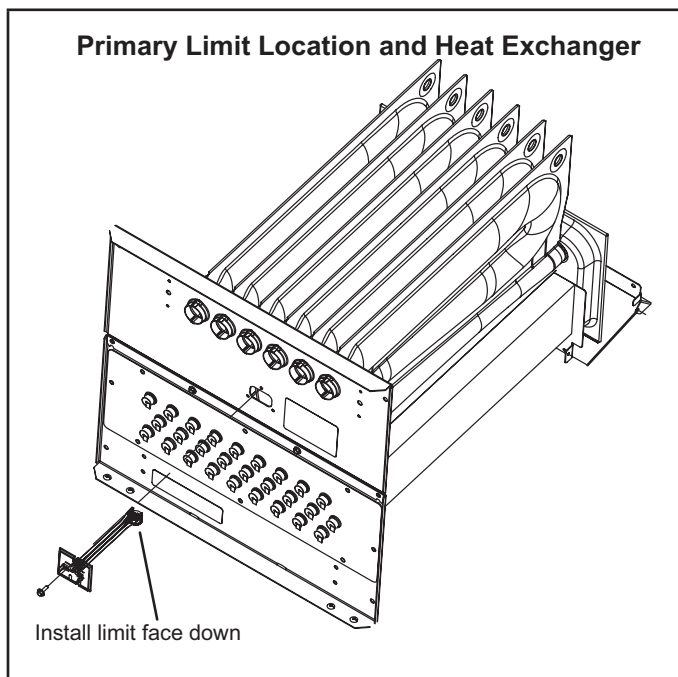

FIGURE 8

## 4. Gas Valve (GV1)

The ML193DFE uses an internally redundant to valve to assure safety shut-off. If the gas valve must be replaced, the same type valve must be used. 24VAC terminals and gas control switch are located on top of the valve. All terminals on the gas valve are connected to wires from the ignition control. 24V applied to the terminals opens the valve. Inlet and outlet pressure taps are located on the valve. A manifold adjustment screw is also located on the valve. An LPG changeover kit is available.

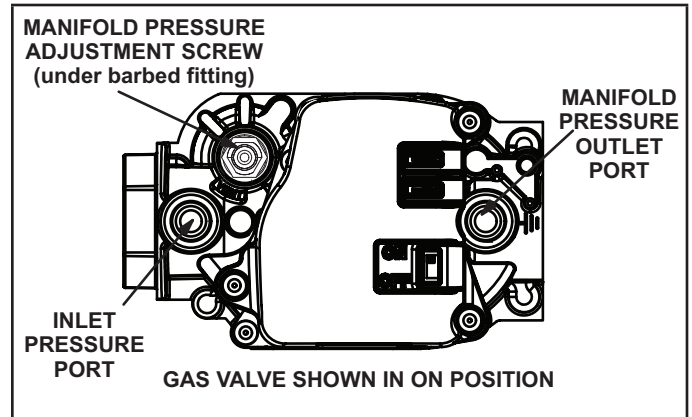

FIGURE 9

## 5. Flame Sensor (FIGURE 8)

A flame sensor is located on the left side of the burner support. The sensor is mounted on the front burner box plate and the tip protrudes into the flame envelope of the leftmost burner. The sensor can be removed for service (use steel wool only to clean) without removing any part of the burners. During operation, flame is sensed by current passed through the flame and sensing electrode. The ignition control allows the gas valve to remain open as long as flame signal is sensed.

**NOTE** - The ML193DFE is polarity sensitive. Make sure that the furnace is wired correctly and is properly grounded.

A microamp DC meter is needed to check the flame signal on the integrated control. Flame (microamp) signal is an electrical current which passes from the integrated control to the sensor during unit operation. Current passes from the sensor through the flame to ground to complete a safety circuit. See FIGURE 10 for sensor flame signal check.

## 6. Ignitor (FIGURE 7)

ML193DFE units use a mini-nitride ignitor made from a proprietary ceramic material. Ignitor longevity is enhanced by controlling the voltage to the ignitor. See FIGURE 11 for resistance and voltage checks.

### To Measure Flame Signal - Integrated Control:

Use a digital readout meter capable of reading DC microamps. See FIGURE 10 for flame signal check.

- 1 - Set the meter to the DC amps scale.
- 2 - Turn off supply voltage to control.
- 3 - Remove sensor wire from integrated control.

- 4 - Connect (-) lead to flame sensor wire.
- 5 - Connect (+) lead to Terminal FS on integrated control.
- 6 - Turn supply voltage on and close thermostat contacts to cycle system.
- 7 - When main burners are in operation for two minutes, take reading.

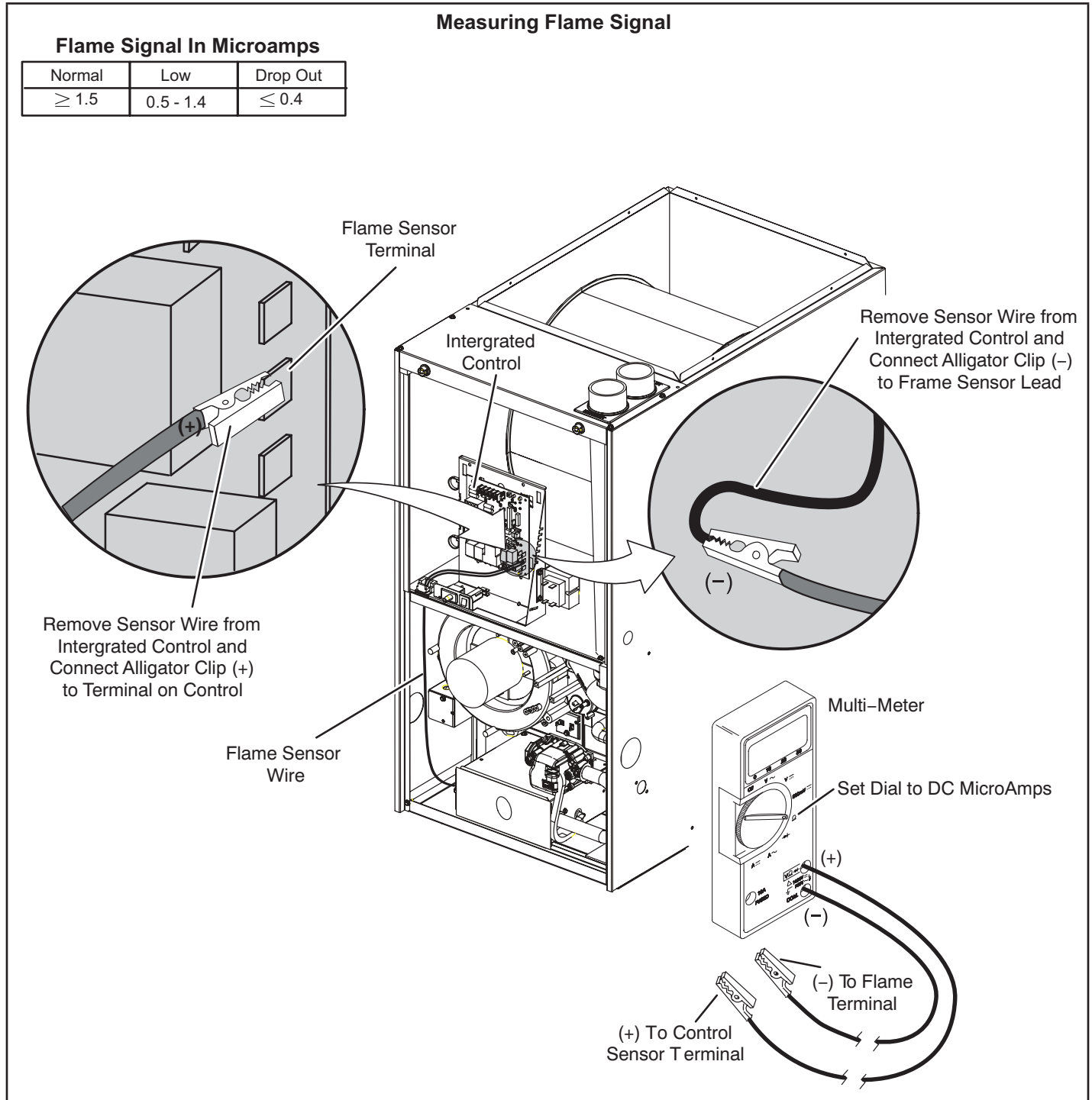
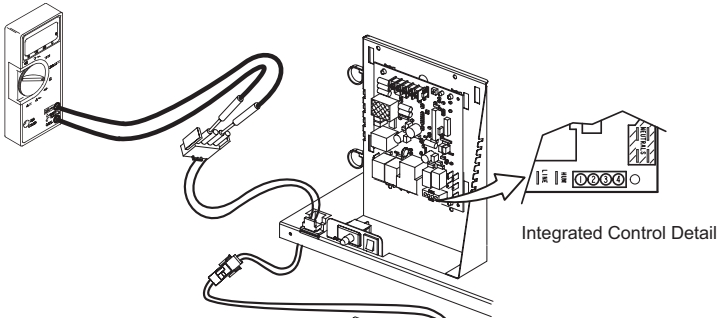
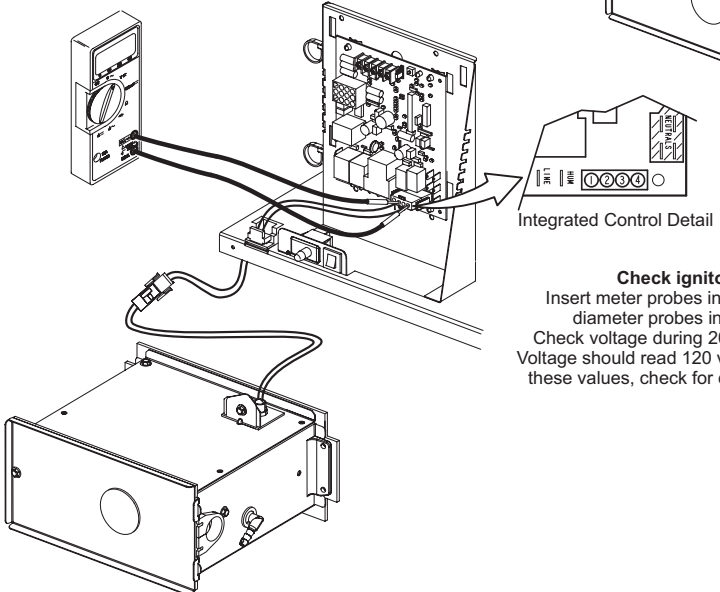
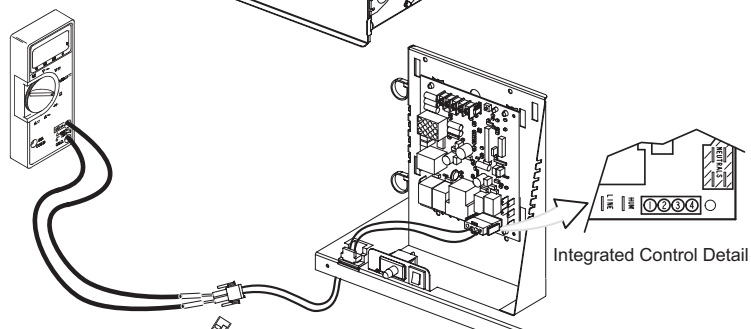

FIGURE 10

**Test 1**  
**Check ignitor circuit for correct resistance.**  
 Remove 4-pin plug from control.  
 Check ohms reading across terminals 2 and 4.  
 Reading should be between 39 and 70 ohms. If  
 value is correct, this is the only test needed.  
 If the reading on the meter is not correct, (0 or  
 infinity) then a second test is needed.



**Test 2**  
**Check ignitor for correct resistance.**  
 Separate the 2-pin jack-plug near the manifold  
 and check resistance of ignitor at the plug.  
 Reading should be between 39 and 70 ohms. If  
 the reading is correct, then the problem is with  
 the wiring between the jack-plug and the control.  
 If reading is not correct, the issue is the ignitor.



**Test 3**  
**Check ignitor for correct voltage**  
 Insert meter probes into terminals 2 and 4 (use small  
 diameter probes in order not to damage plug).  
 Check voltage during 20 second ignitor warm up period.  
 Voltage should read 120 volts  $\pm$  10%. If voltage reads below  
 these values, check for correct supply voltage to furnace.

**FIGURE 11**

## 7. Combustion Air Inducer (B6)

### & Cold End Header Box

All ML193DFE units use a combustion air inducer to move air through the burners and heat exchanger during heating operation. The blower uses a shaded pole 120VAC motor. The motor operates during all heating operation and is controlled by burner ignition control A3. Blower operates continuously while there is a call for heat. The burner ignition control will not proceed with the ignition sequence until combustion air inducer operation is sensed by the proving switches.

The CAI is installed on the cold end header box. The cold end header box is a single piece made of hard plastic. The box has an internal channel where the combustion air inducer creates negative pressure at unit start up. The channel contains an orifice used to regulate flow created by the CAI. The box has pressure taps for the CAI pressure switch hoses. The pressure switch measure the pressure across the CAI orifice or difference in the channel and the box. **If replacement is necessary the gaskets used to seal the box to the vestibule panel and the CAI to the box, must also be replaced.**

**TABLE 6**

ML193DFE Unit	C.A.I. Orifice Size in.
-045	0.700
-070	1.025
-090	1.120

## 8. Combustion Air Pressure Switch (FIGURE 12)

ML193DFE series units are equipped with a differential pressure switch located on the cold end header box. The switches monitor across the CAI orifice to insure proper flow through the heat exchanger.

The switch is a SPST N.O. prove switch electrically connected to the integrated control. The purpose of the switch is to prevent burner operation if the combustion air inducer is not moving enough air for proper combustion.

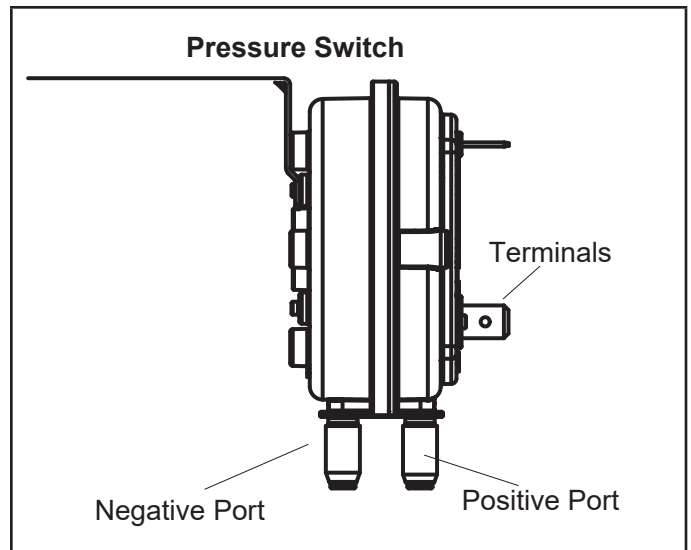

**FIGURE 12**

On start-up, the switch senses that the combustion air inducer is operating. It closes a circuit to the ignition control when the difference in pressure across the CAI orifice exceeds a non-adjustable factory setting. If the switch does not successfully sense the required differential, the switch cannot close and the furnace cannot operate. If the flue or air inlet become obstructed during operation, the switch senses a loss of pressure differential and opens the circuit to the ignition control. If the condensate line is blocked, water will back up into the header box and reduce the pressure differential across the switch. The prove switch opens if the differential drops below the set point. See TABLE 7

Checks of pressure differential can aid in troubleshooting. When measuring the pressure differential, readings should be taken at the pressure switch. See FIGURE 13. Lack of differential usually indicates problems in the intake or exhaust piping, but may indicate problems in the heat exchanger, condensing coil, header boxes, combustion inducer or other components.

**TABLE 7**

ML196DFE Unit	Altitude ft		
	0-4500	4501-7500	7501-10,000
	Set Point	Set Point	Set Point
-045			
-070	-0.65	-0.60	-0.55
-090			

*\*Set point is factory set and non-adjustable*

## Measuring Pressure Differential

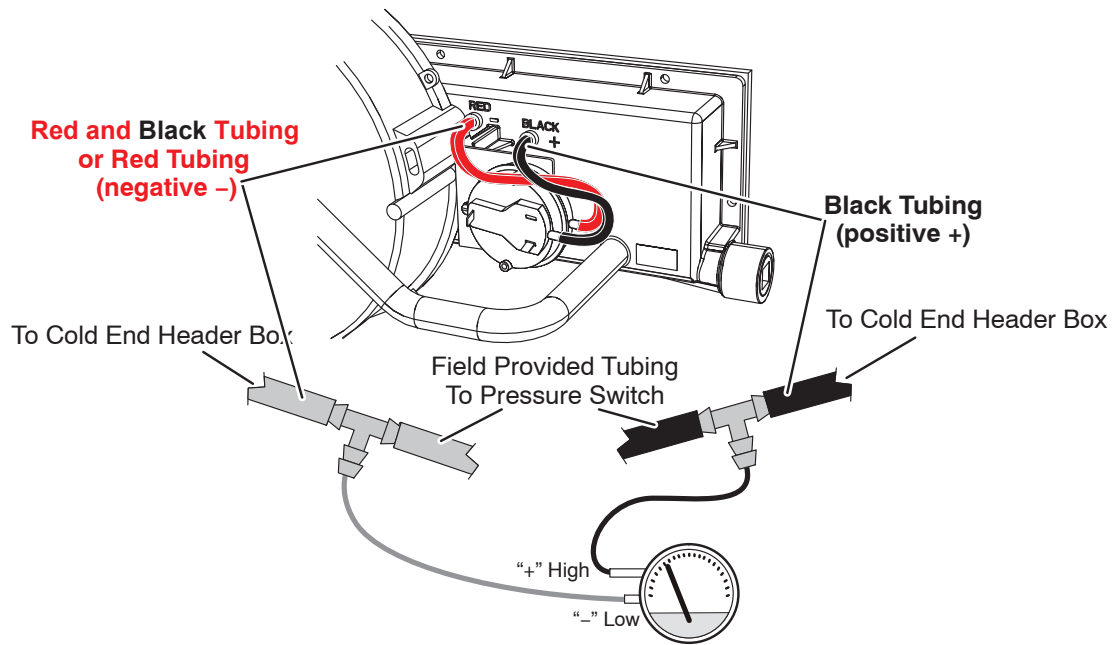

- 1 - Remove thermostat demand and allow unit to cycle off.
- 2 - Install a tee in the negative (-) line (red and black tubing or red tubing) and a tee in the positive (+) line (black tubing) running from the pressure switch to the cold end header box.
- 3 - Install a manometer with hose from the negative (-) side of the manometer to the tee installed in the negative (-) line and with hose from the positive (+) side of the manometer to the tee in the positive (+) line.

*NOTE - Both sides of the cold end header box are negative. However the (+) port reads less negative pressure than the (-) port.*

- 4 - Operate unit and observe manometer reading.  
*Readings will change as heat exchanger warms.*
  - a. Take one reading immediately after start-up.
  - b. Take a second reading after unit has reached steady state (approximately 5 minutes). This will be the pressure differential.

**The pressure differential should be greater than those listed in table 7.**

- 5 - Remove thermostat demand and allow to cycle off.
- 6 - Remove manometer and tee's. Reinstall combustion air sensing hoses to the pressure switch.

**FIGURE 13**



**TABLE 8**

<b>Problem</b>	<b>Corrective Action</b>
Pressure switch stuck closed	Check that the pressure switch is open without the combustion air inducer operating. Replace if defective.
Pressure switch does not close due to obstruction in vent pipe.	Check for restricted vent. Remove all blockage. Check for proper vent sizing. See table 13.
Pressure switch does not close due to incorrect routing of the pressure switch tubing.	Check that the pressure switch tubing is correctly routed. Correctly route pressure switch line.
Pressure switch does not close due to obstructions in the pressure switch line.	Remove any obstructions from the the pressure switch line and/or taps
Pressure switch tubing damaged.	Check pressure switch tubing for leaks. Replace damaged tubing if necessary.
Condensate in pressure switch tubing.	Check pressure switch tubing for condensate. Remove condensate from tubing.
Pressure switch does not close due to a low differential pressure across the pressure switch.	Check the differential pressure across the pressure switch. Check for restricted inlet vent. Remove all blockage. Check for proper vent sizing and run length. See table 13.
Wrong pressure switch installed in the unit, or pressure switch is out of calibration	Check that the correct pressure switch is installed in the unit. Replace pressure switch if necessary.
Miswiring of furnace or improper connections at pressure switch.	Check for correct wiring and loose connections. Correct wiring and/or replace any loose connections.
Pressure switch failure.	If all the above modes of failure have been checked, the pressure switch may have failed. Replace pressure switch and determine if unit will operate.
Damaged condensate trap.	Check trap for any cracks or damage and replace if necessary.
Cold end header box does not drain properly.	Check that the furnace is set properly with a slight tilt (0 - 1/2") towards the front if necessary. See furnace installation instruction.
Air leakage around the combustion air inducer gasket.	Check gasket and replace if necessary.
Air leakage around the cold end header box gasket.	Check gasket and replace if necessary.
Damaged cold end header box tubing.	Check tubing and replace if necessary.

## C-Blower Compartment

### **! IMPORTANT**

Each blower is statically and dynamically balanced as an assembly before installation in the unit.

EL196DFE units are equipped with a constant torque ECM motor. It has a DC motor coupled to an electronic control module both contained in the same motor housing. The motor is programmed to provide constant torque at each of the five selectable speed taps. Each tap requires 24 volts to energize.

### Input Voltage Requirements

The circuit is designed to be operated with AC voltage. To enable a tap requires 12 to 33VAC. Expected current draw will be less than 20mA.

### Troubleshooting the Motor

Troubleshooting the motor is an easy process. Follow steps below.

- 1 - Shut off power to unit.
- 2 - Remove input connectors J48 and J49 from motor. See FIGURE 17 for troubleshooting procedure.

**Note** - FIGURE 17 is a typical ignition control illustration.

If correct voltage is present in tests 1 and 2 and motor is not operating properly, replace motor. The motor is not field repairable.

If replacing the indoor blower motor or blower wheel is necessary, placement is critical. The blower wheel must be centered in the blower housing as shown in FIGURE 14. When replacing the indoor blower motor the set screw must be aligned and tightened with the motor shaft as shown in FIGURE 15.

### Secondary Limit Controls

The secondary limit is located in the blower compartment on the back side of the blower housing. See FIGURE 16. When excess heat is sensed in the blower compartment, the limit will open. If the limit is open, the furnace control energizes the supply air blower and closes the gas valve. The limit automatically resets when unit temperature returns to normal. The secondary limit cannot be adjusted.

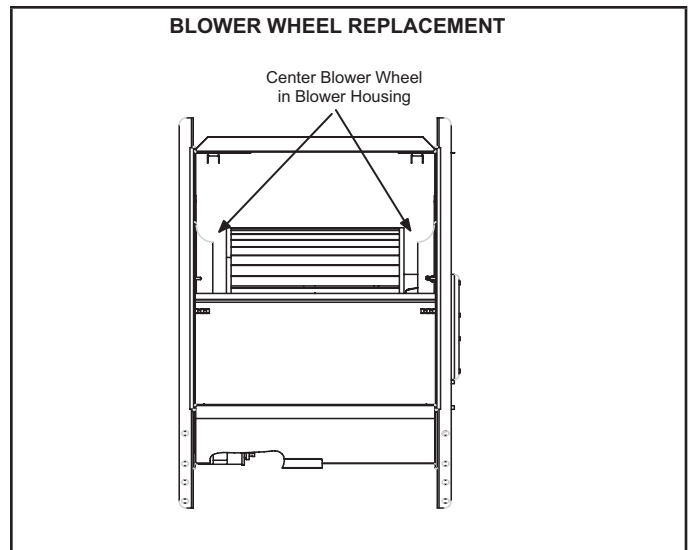

FIGURE 14

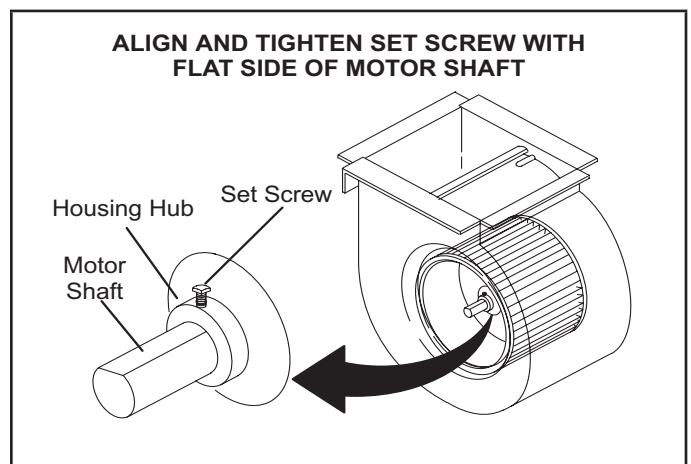

FIGURE 15

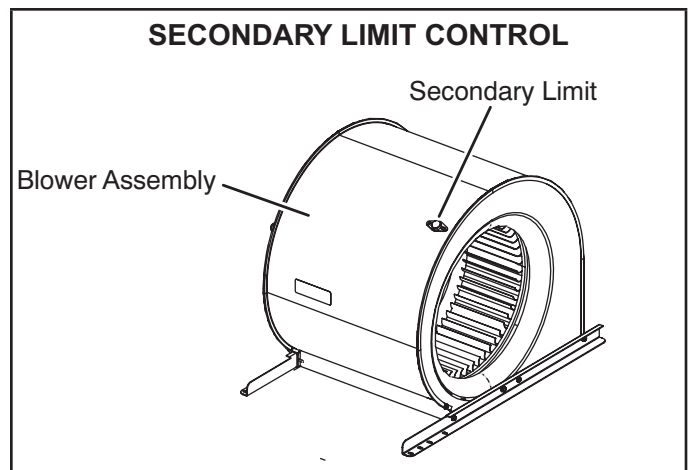
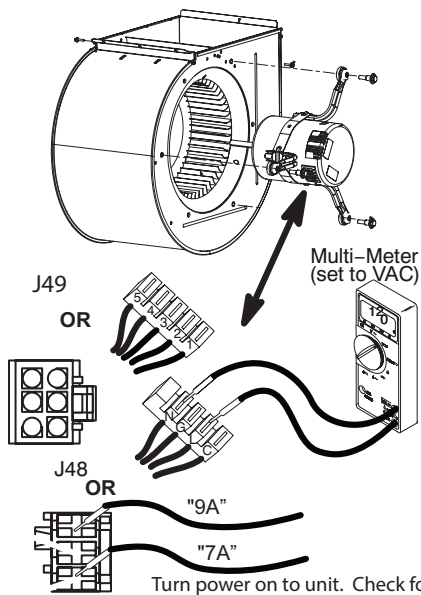
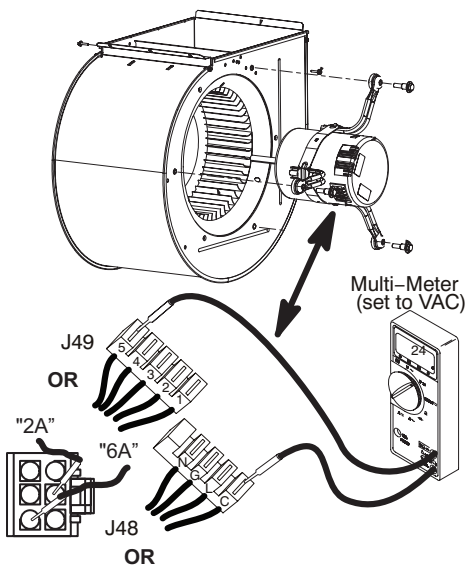

FIGURE 16



**Test 1**

Turn power on to unit. Check for 120 volts across terminals "L" and "N" or terminals "7A" and "9A" of connector J48. If voltage is present continue to test 2. If voltage is not present problem may be upstream of J48. Proceed to test3.



**Test 2**

Switch thermostat to CONTINUOUS FAN MODE. For units using 4 and 5 position connector blocks, test for 24 volts terminal "C" of J48 and the tap used for continuous fan on J49 (1, 2, 3, 4 or 5). For units using 3 and 6 position connectors, test for 24 volts between pin "6A" and the pin used for continuous fan on connector J49 (1., 2, 3, 4 or 5).

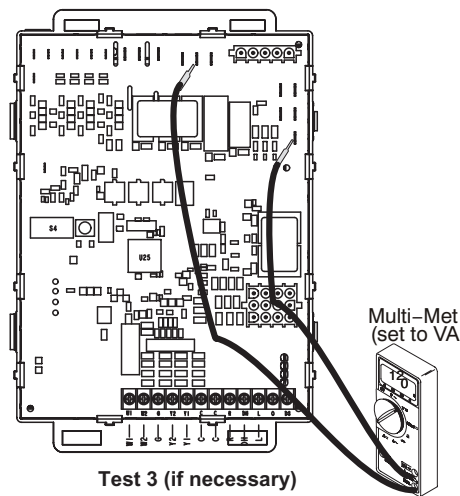

**Test 3 (if necessary)**

**NOTE- Ignition control illustration is typical**

Check for 120 volts across terminals "L1" and "Neutrals" on the integrated control. If voltage is present, problem is with the harness. If voltage is not present problem may be with the integrated control.

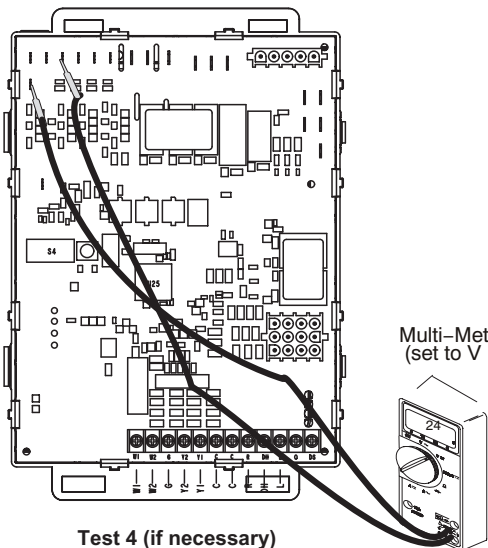

**Test 4 (if necessary)**

**NOTE- Ignition control illustration is typical**

Check for 24 volts across terminals "24 COM" and the "active speed tap" on the integrated control. If voltage is present, problem is with the harness. If voltage is not present problem may be with the integrated control

**FIGURE 17**

## Replacing the Motor Module

**NOTE** - Not all motors have field replaceable control modules. Only motors that utilize a 4 pin power connector and 5 pin signal connector as shown below may have replaceable controls. Motors that use a 3 pin power connector and 6 pin signal connector do not have field replaceable control modules. In the event of failure, the entire motor must be replaced.

- 1 - Disconnect electrical power to unit.
- 2 - Remove unit access panel.
- 3 - Unplug the two harnesses from the motor control module. See FIGURE 18.

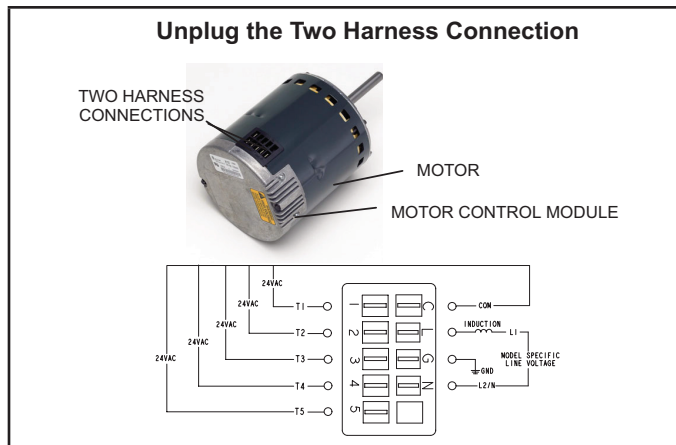

FIGURE 18

- 4 - Remove the two hex head bolts securing the motor control module to the motor (FIGURE 19).
- 5 - Slide the motor control module away from the motor to access and disconnect the internal three wire connector. It is not necessary to remove blower motor itself. Set both hex head bolts aside.



FIGURE 19

### Testing the Motor (FIGURE 20)

If any motor fails the below tests, do not install the new control module. The motor is defective and it also must be replaced. The new control can fail if placed on a defective motor.

- 1 - Using an ohmmeter check the resistance from any one of the motor connector pins to the aluminum end plate of the motor. This resistance should be greater than 100k ohms.
- 2 - Check the resistances between each of the three motor connector pins. These should all read

- approximately the same resistance within an ohm.
- 3 - Check to see if the blower wheel spins freely



FIGURE 20

TABLE 9

Scale	Measurement range in words	ohms
2 M	two megohm-two million ohms	0 - 2,000,000
200 K	two hundred kilo-ohm-two hundred thousand ohms	0 - 200,000
20 K	twenty kilo-ohm-twenty thousand ohms	0 - 20,000
2 K	two kilo-ohm two-thousand ohms	0 - 2,000
200	two hundred ohms	0 - 200

### Motor Module Installation

All replacement motor control modules look similar; however, each module is designed for a specific motor size. It is very important to make sure that you are using the correct replacement motor control module. **USE OF THE WRONG MOTOR CONTROL MODULE MAY RESULT IN UNEXPECTED UNIT OPERATION.**

- 1 - Verify electrical power to unit is disconnected.
- 2 - Connect three-wire harness from motor to control module.
- 3 - Mount new motor control module to motor using two hex head bolts removed in FIGURE 19. Torque bolts to 22 inch pounds or 1/16th clock turn as exemplified to the right.
- 4 - Reconnect the two harnesses to the motor control module.
- 5 - The electrical connectors of the motor should be facing down to form a drip loop (FIGURE 21). This will direct moisture away from the motor and its electric connections on the motor.

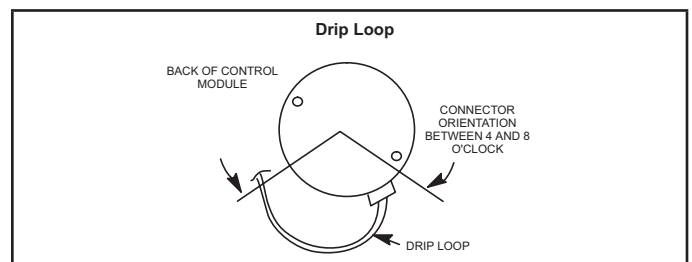

FIGURE 21

## II-PLACEMENT AND INSTALLATION

### Pipe & Fittings Specifications

All pipe, fittings, primer and solvent cement must conform with American National Standard Institute and the American Society for Testing and Materials (ANSI/ASTM) standards. The solvent shall be free flowing and contain no lumps, undissolved particles or any foreign matter that adversely affects the joint strength or chemical resistance of the cement. The cement shall show no gelation, stratification, or separation that cannot be removed by stirring. Refer to TABLE 10 for approved piping and fitting materials.

**TABLE 10**

#### PIPING AND FITTINGS SPECIFICATIONS

Schedule 40 PVC (Pipe)	D1785
Schedule 40 PVC (Cellular Core Pipe)*	F891
Schedule 40 PVC (Fittings)	D2466
Schedule 40 CPVC (Pipe)	F441
Schedule 40 CPVC (Fittings)	F438
SDR-21 PVC or SDR-26 PVC (Pipe)	D2241
SDR-21 CPVC or SDR-26 CPVC (Pipe)	F442
Schedule 40 ABS Cellular Core DWV (Pipe)*	F628
Schedule 40 ABS (Pipe)	D1527
Schedule 40 ABS (Fittings)	D2468
ABS-DWV (Drain Waste & Vent) (Pipe & Fittings)	D2661
PVC-DWV (Drain Waste & Vent) Pipe & Fittings)	D2665
<b>PRIMER &amp; SOLVENT CEMENT</b>	<b>ASTM SPECIFICATION</b>
PVC & CPVC Primer	F656
PVC Solvent Cement	D2564
CPVC Solvent Cement	F493
ABS Solvent Cement	D2235
PVC/CPVC/ABS All Purpose Cement For Fittings & Pipe of the same material	D2564, D2235, F493
ABS to PVC or CPVC Transition Solvent Cement	D3138
<b>CANADA PIPE &amp; FITTING &amp; SOLVENT CEMENT</b>	<b>MARKING</b>
PVC & CPVC Pipe and Fittings	ULCS636
PVC & CPVC Solvent Cement	
ABS to PVC or CPVC Transition Cement	
<b>POLYPROPYLENE VENTING SYSTEM</b>	
PolyPro® by Duravent	UL1738
InnoFlue® by Centrotherm	
<b>UL 1738 CERTIFIED GAS VENTING SYSTEM</b>	
IPEX System1738 Schedule 40 PVC Pipes and Fittings	UL1738
IPEX System1738 PVC FGV Cement & Primer	

\* Not approved as of 12-1-2022

## IMPORTANT

Exhaust and intake connections are made of PVC. Use PVC primer and solvent cement when using PVC vent pipe. When using ABS vent pipe, use transitional solvent cement to make connections to the PVC fittings in the unit.

## CAUTION

Solvent cements for plastic pipe are flammable liquids and should be kept away from all sources of ignition. Do not use excessive amounts of solvent cement when making joints. Good ventilation should be maintained to reduce fire hazard and to minimize breathing of solvent vapors. Avoid contact of cement with skin and eyes.

Use PVC primer and solvent cement or ABS solvent cement meeting ASTM specifications, refer to TABLE 10. As an alternate, use all purpose cement, to bond ABS, PVC, or CPVC pipe when using fittings and pipe made of the same materials. Use transition solvent cement when bonding ABS to either PVC or CPVC.

Low temperature solvent cement is recommended during cooler weather. Metal or plastic strapping may be used for vent pipe hangers. Uniformly apply a liberal coat of PVC primer for PVC or use a clean dry cloth for ABS to clean inside socket surface of fitting and male end of pipe to depth of fitting socket.

**Canadian Applications Only** - Pipe, fittings, primer and solvent cement used to vent (exhaust) this appliance must be certified to ULC S636 and supplied by a single manufacturer as part of an approved vent (exhaust) system. In addition, the first three feet of vent pipe from the furnace flue collar must be accessible for inspection.

**TABLE 11  
OUTDOOR TERMINATION USAGE\***

Input Size	Vent Pipe Dia. in.	STANDARD				CONCENTRIC		
		Flush Mount Kit	Wall Kit		Field Fabricated	1-1/2 inch	2 inch	3 inch
			2 inch	3 inch		71M80 (US) 444W92 (CA)	69M29 (US) 444W92 (CA)	60L46 (US) 444W93 (CA)
51W11 (US) 51W12 (CA)	22G44 (US) 30G28 (CA)	44J40 (US) 81J20 (CA)						
045	<sup>6</sup> 1-1/2	<sup>3</sup> YES	YES	<sup>1</sup> YES	<sup>5</sup> YES	<sup>2</sup> YES	N/A	N/A
	2	<sup>3</sup> YES	YES	<sup>1</sup> YES	<sup>5</sup> YES	<sup>2</sup> YES		
	2-1/2	<sup>3</sup> YES	YES	<sup>1</sup> YES	<sup>5</sup> YES	<sup>2</sup> YES		
	3	<sup>3</sup> YES	YES	<sup>1</sup> YES	<sup>5</sup> YES	<sup>2</sup> YES		
070	<sup>6</sup> 1-1/2	<sup>3</sup> YES	YES	<sup>1</sup> YES	<sup>5</sup> YES	<sup>2</sup> YES		
	2	<sup>3</sup> YES	YES	<sup>1</sup> YES	<sup>5</sup> YES	<sup>2</sup> YES		
	2-1/2	<sup>3</sup> YES	YES	<sup>1</sup> YES	<sup>5</sup> YES	<sup>2</sup> YES		
	3	<sup>3</sup> YES	YES	<sup>1</sup> YES	<sup>5</sup> YES	<sup>2</sup> YES		
090	2	<sup>3</sup> YES	N/A	YES	<sup>5</sup> YES	N/A	YES	YES
	2-1/2	<sup>3</sup> YES		YES	<sup>5</sup> YES		YES	YES
	3	<sup>3</sup> YES		YES	<sup>5</sup> YES		YES	YES

**NOTE** - Standard terminations do not include any vent pipe or elbows external to the structure. Any vent pipe or elbows external to the structure must be included in total vent length calculations. See vent length tables.

\* Kits must be properly installed according to kit instructions.

<sup>1</sup> Requires field-provided outdoor 1-1/2" exhaust accelerator.

<sup>2</sup> Concentric kits 71M80 and 44W92 include 1-1/2" outdoor accelerator, when uses with 045 and 070 input models. When using 1-1/2 inch vent pipe, transition to 2" pipe before installing concentric kit.

<sup>3</sup> Flush mount kits 51W11 and 51W12 includes 1-1/2 in. outdoor exhaust accelerator, required when used with 045, 070 and 090 input models. When using 1-1/2 inch vent pipe, transition to

2" pipe before installing flushmount kit..

<sup>4</sup> Termination kits 30G28, 44W92, 4493 and 81J20 are certified to ULC S636 for use in Canada only.

<sup>5</sup> See TABLE 16 for vent accelerator requirements.

<sup>6</sup> Requires field provided 2" to 1-1/2" reducer.

## Joint Cementing Procedure

All cementing of joints should be done according to the specifications outlined in ASTM D 2855.

**NOTE** - A sheet metal screw may be used to secure the intake pipe to the connector, if desired. Use a drill or self tapping screw to make a pilot hole.

## **! DANGER**

### **DANGER OF EXPLOSION!**

**Fumes from PVC glue may ignite during system check. Allow fumes to dissipate for at least 5 minutes before placing unit into operation.**

- 1 - Measure and cut vent pipe to desired length.
- 2 - Debur and chamfer end of pipe, removing any ridges or rough edges. If end is not chamfered, edge of pipe may remove cement from fitting socket and result in a leaking joint

**NOTE** - Check the inside of vent pipe thoroughly for any obstruction that may alter furnace operation

- 3 - Clean and dry surfaces to be joined.
- 4 - Test fit joint and mark depth of fitting on outside of pipe.
- 5 - Uniformly apply a liberal coat of PVC primer for PVC or use a clean dry cloth for ABS to clean inside socket surface of fitting and male end of pipe to depth of fitting socket.
- 6 - Promptly apply solvent cement to end of pipe and inside socket surface of fitting. Cement should be applied lightly but uniformly to inside of socket. Take care to keep excess cement out of socket. Apply second coat to end of pipe.

**NOTE** - Time is critical at this stage. Do not allow primer to dry before applying cement.

- 7 - Immediately after applying last coat of cement to pipe, and while both inside socket surface and end of pipe are wet with cement, forcefully insert end of pipe into socket until it bottoms out. Turn PVC pipe 1/4 turn during assembly (but not after pipe is fully inserted) to distribute cement evenly. DO NOT turn ABS or cellular core pipe.

**NOTE** - Assembly should be completed within 20 seconds after last application of cement. Hammer blows should not be used when inserting pipe.

- 8 - After assembly, wipe excess cement from pipe at end of fitting socket. A properly made joint will show a bead around its entire perimeter. Any gaps may indicate an improper assembly due to insufficient solvent.
- 9 - Handle joints carefully until completely set.

## Venting Practices

### HORIZONTAL PIPING SUPPORT GUIDELINES

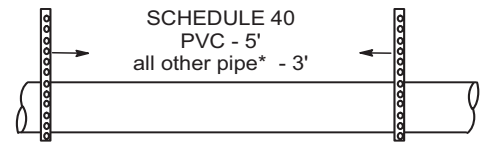

\* See Piping and Fittings Specifications table

**NOTE** - Vertical support guidelines: Recommend following the guidelines in the International Plumbing code for PVC.

**NOTE** - Isolate piping at the point where it exits the outside wall or roof in order to prevent transmission of vibration to the structure.

### Wall Thickness Guidelines

24" maximum  
3/4" minimum

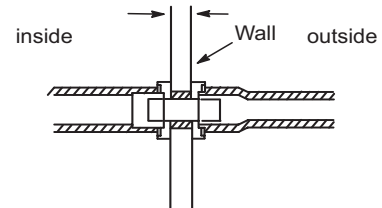
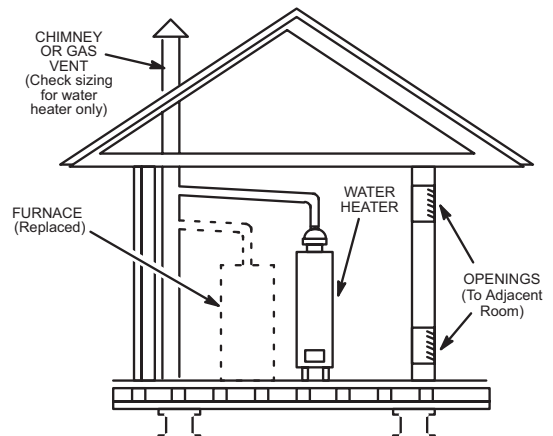

FIGURE 22

### REPLACING FURNACE THAT WAS PART OF A COMMON VENT SYSTEM



If replacing a furnace which was commonly vented with another gas appliance, the size of the existing vent pipe for that gas appliance must be checked. Without the heat of the original furnace flue products, the existing vent pipe is probably oversized for the single water heater or other appliance. The vent should be checked for proper draw with the remaining appliance.

FIGURE 23

- 1 - In areas where piping penetrates joists or interior walls, hole must be large enough to allow clearance on all sides of pipe through center of hole using a hanger.
- 2 - When furnace is installed in a residence where unit is shut down for an extended period of time, such as a vacation home, make provisions for draining condensate collection trap and lines.

### Removal of the Furnace from Common Vent

In the event that an existing furnace is removed from a venting system commonly run with separate gas appliances, the venting system is likely to be too large to properly vent the remaining attached appliances. Conduct the following test while each appliance is operating and the other appliances (which are not operating) remain connected to the common venting system. If the venting system has been installed improperly, you must correct the system as indicated in the general venting requirements section.

 <b>WARNING</b>
<b>CARBON MONOXIDE POISONING HAZARD</b> Failure to follow the steps outlined below for each appliance connected to the venting system being placed into operation could result in carbon monoxide poisoning or death. The following steps shall be followed for each appliance connected to the venting system being placed into operation, while all other appliances connected to the venting system are not in operation:

- 1 - Seal any unused openings in the common venting system.
- 2 - Inspect the venting system for proper size and horizontal pitch. Determine that there is no blockage, restriction, leakage, corrosion, or other deficiencies which could cause an unsafe condition.
- 3 - Close all building doors and windows and all doors between the space in which the appliances remaining connected to the common venting system are located and other spaces of the building. Turn on clothes dryers and any appliances not connected to the common venting system. Turn on any exhaust fans, such as range hoods and bathroom exhausts, so they will operate at maximum speed. Do not operate a summer exhaust fan. Close fireplace dampers.
- 4 - Follow the lighting instructions. Turn on the appliance that is being inspected. Adjust the thermostat so that the appliance operates continuously.
- 5 - After the main burner has operated for 5 minutes, test for leaks of flue gases at the draft hood relief opening. Use the flame of a match or candle.

- 6 - After determining that each appliance connected to the common venting system is venting properly, (step 3) return all doors, windows, exhaust fans, fireplace dampers, and any other gas-burning appliances to their previous mode of operation.
- 7 - If a venting problem is found during any of the preceding tests, the common venting system must be modified to correct the problem. Resize the common venting system to the minimum vent pipe size determined by using the appropriate tables in Appendix G. (These are in the current standards of the National Fuel Gas Code ANSI Z223.1.

### Exhaust Piping (FIGURE 25 and FIGURE 26)

Route piping to outside of structure. Continue with installation following instructions given in piping termination section.

 <b>CAUTION</b>
<b>Do not discharge exhaust into an existing stack or stack that also serves another gas appliance. If vertical discharge through an existing unused stack is required, insert PVC pipe inside the stack until the end is even with the top or outlet end of the metal stack.</b>

 <b>CAUTION</b>
<b>The exhaust vent pipe operates under positive pressure and must be completely sealed to prevent leakage of combustion products into the living space.</b>

### Vent Piping Guidelines

**NOTE** - Lennox has approved the use of DuraVent® and Centrotherm manufactured vent pipe and terminations as an option to PVC. When using the PolyPro® by DuraVent or InnoFlue® by Centrotherm venting system the vent pipe requirements stated in the unit installation instruction – minimum & maximum vent lengths, termination clearances, etc. – apply and must be followed. Follow the instructions provided with PolyPro by DuraVent and InnoFlue by Centrotherm venting system for assembly or if requirements are more restrictive. The PolyPro by DuraVent and InnoFlue by Centrotherm venting system must also follow the uninsulated and unconditioned space criteria listed in TABLE 15.

**The ML193DFE can be installed as either a Non-Direct Vent or a Direct Vent gas central furnace.**

**NOTE** - In Direct Vent installations, combustion air is taken from outdoors and flue gases are discharged outdoors. In Non-Direct Vent installations, combustion air is taken from indoors or ventilated attic or crawlspace and flue gases are discharged outdoors.

**Intake and exhaust pipe sizing** -- Size pipe according to TABLE 12 (minimum length permitted) and TABLE 13 (maximum length permitted). Count all elbows inside and outside the home.



**TABLE 12**  
**MINIMUM VENT PIPE LENGTHS**

ML193DFE MODEL	MIN. VENT LENGTH*
045, 070, 090	15 ft or 5ft plus 2 elbows or 10 ft plus 1 elbow

\*Any approved termination may be added to the minimum length listed. Two 45 degree elbows are equivalent to one 90 degree elbow.

Regardless of the diameter of pipe used, the standard roof and wall terminations described in section Exhaust Piping Terminations should be used. Exhaust vent termination pipe is sized to optimize the velocity of the exhaust gas as it exits the termination. Refer to TABLE 16.

In some applications which permit the use of several different sizes of vent pipe, a combination vent pipe may be used. Contact Lennox' Application Department for assistance in sizing vent pipe in these applications.

**⚠ CAUTION**

**Do not use screens or perforated metal in exhaust or intake terminations. Doing so will cause freeze-ups and may block the terminations.**

Use the following steps to correctly size vent pipe diameter.

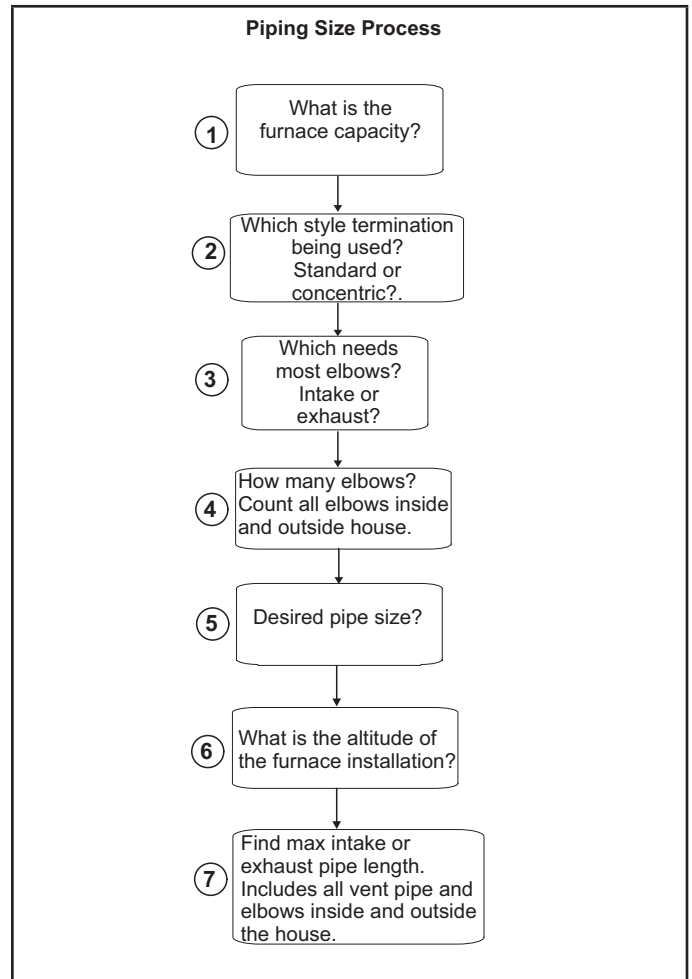

**FIGURE 24**

**NOTE** - It is acceptable to use any pipe size which fits within the guidelines allowed in table 13.

**NOTE** - All horizontal runs of exhaust pipe must slope back toward unit. A minimum of 1/4" (6mm) drop for each 12" (305mm) of horizontal run is mandatory for drainage.

**NOTE** - Exhaust pipe **MUST** be glued to furnace exhaust fittings.

**NOTE** - Exhaust piping should be checked carefully to make sure there are no sags or low spots.

**TABLE 13**

**Maximum Allowable Intake or Exhaust Vent Length in Feet**

\*Size intake and exhaust pipe length separately. Values in table are for Intake OR Exhaust, not combined total. Both Intake and Exhaust must be same pipe size.

**NOTE - Additional vent pipe and elbows used to terminate the vent pipe outside the structure must be included in the total vent length calculation.**

Standard Termination at Elevation 0 - 10,000 ft.												
Number Of 90° Elbows Used	1-1/2" Pipe			2" Pipe			2-1/2" Pipe			3" Pipe		
	Model			Model			Model			Model		
	045	070	090	045	070	090	045	070	090	045	070	090
1	20	15	n/a	61	46	24	100	80	43	127	127	108
2	15	10		56	41	19	95	75	38	122	122	103
3	10	n/a		51	36	14	90	70	33	117	117	98
4	n/a			46	31	n/a	85	65	28	112	112	93
5				41	26		80	60	23	107	107	88
6				36	21		75	55	18	102	102	83
7				31	16		70	50	13	97	97	78
8				26	11		65	45	n/a	92	92	73
9				21	n/a		60	40		87	87	68
10				16			55	35		82	82	63
Concentric Termination Elevation 0 - 10,000 ft.												
Number Of 90° Elbows Used	1-1/2" Pipe			2" Pipe			2-1/2" Pipe			3" Pipe		
	Model			Model			Model			Model		
	045	070	090	045	070	090	045	070	090	045	070	090
1	15	10	n/a	53	38	22	90	70	39	111	111	104
2	10	n/a		48	33	17	85	65	34	106	106	99
3	n/a			43	28	12	80	60	29	101	101	94
4				38	23	n/a	75	55	19	96	96	89
5				33	18		70	50	14	91	91	84
6				28	13		65	45	n/a	86	86	79
7				23	n/a		60	40		81	81	74
8				18			55	35		76	76	69
9				13			50	30	71	71	64	
10				n/a	45		25	66	66	59		

**TABLE 14**

**Maximum Allowable Exhaust Vent Lengths With Furnace Installed in a Closet or Basement Using Ventilated Attic or Crawl Space For Intake Air in Feet**

**NOTE - Additional vent pipe and elbows used to terminate the vent pipe outside the structure must be included in the total vent length calculation.**

Standard Termination at Elevation 0 - 10,000 ft.												
Number Of 90° Elbows Used	1-1/2" Pipe			2" Pipe			2-1/2" Pipe			3" Pipe		
	Model			Model			Model			Model		
	045	070	090	045	070	090	045	070	090	045	070	090
1	15	10	n/a	51	36	14	85	65	28	107	107	88
2	10	n/a		46	31	9	80	60	23	102	102	83
3	n/a			41	26	4	75	55	18	97	97	78
4				36	21	n/a	70	50	8	92	92	73
5				31	16		65	45	3	87	87	68
6				26	11		60	40	n/a	82	82	63
7				21	6		55	35		77	77	58
8				16	1		50	30		72	72	53
9				11	n/a		45	25	67	67	48	
10				6			40	20	62	62	43	

**TYPICAL EXHAUST PIPE CONNECTIONS**

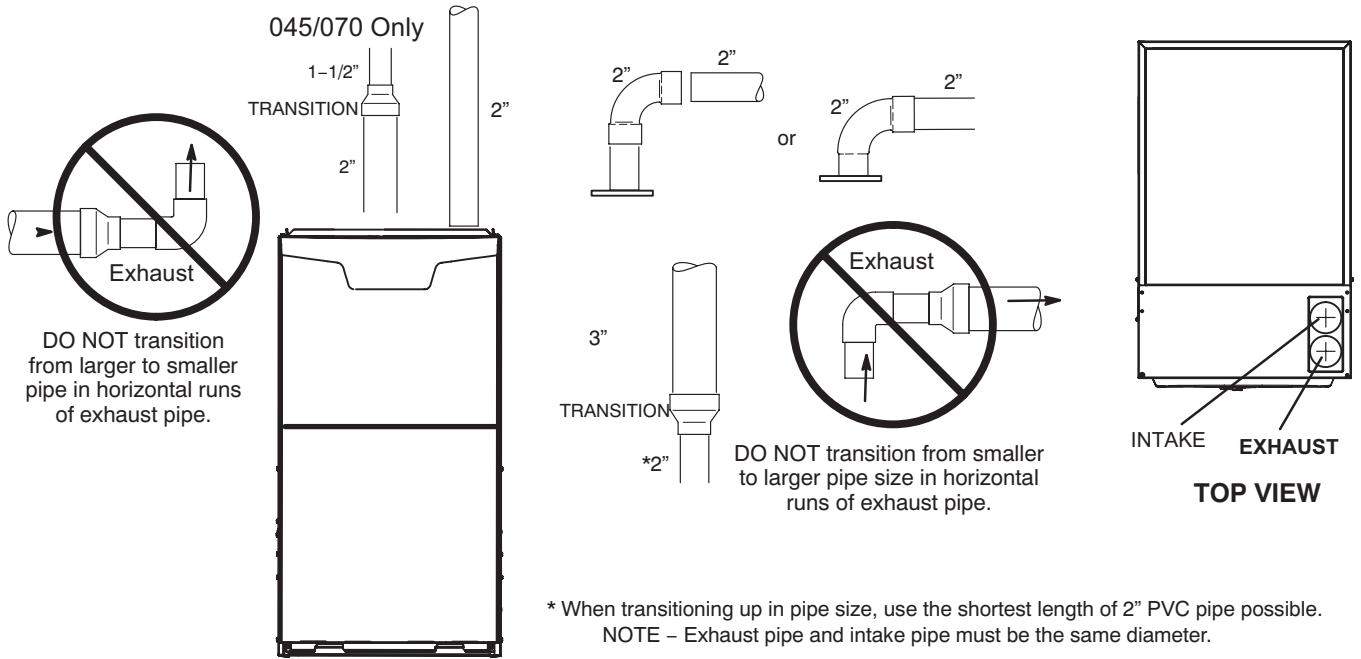

**FIGURE 25**

**TYPICAL INTAKE PIPE CONNECTIONS**

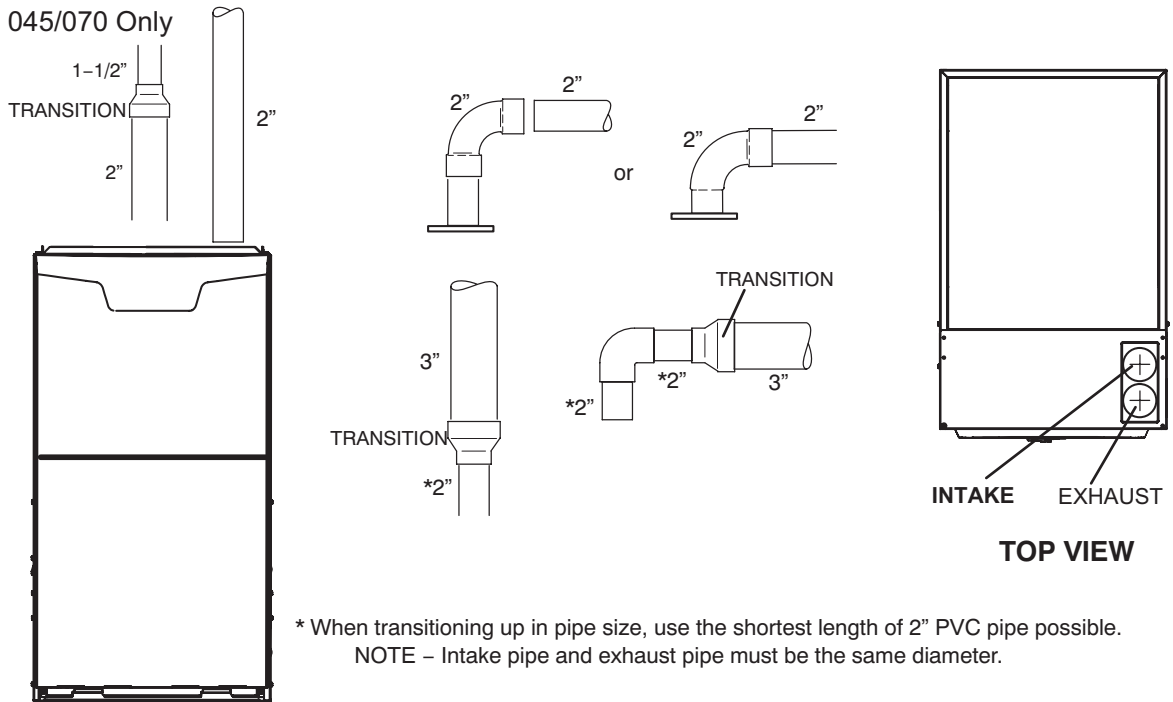

**FIGURE 26**

## Intake Piping

The ML193DFE furnace may be installed in either direct vent or non-direct vent applications. In non-direct vent applications, when intake air will be drawn into the furnace from the surrounding space, the indoor air quality must be considered. Guidelines listed in Combustion, Dilution and Ventilation Air section must be followed.

Follow the next two steps when installing the unit in **Direct Vent applications**, where combustion air is taken from outdoors and flue gases are discharged outdoors. **The provided air intake screen must not be used in direct vent applications (outdoors).**

- 1 - Use cement to secure the intake pipe to the inlet air connector.
- 2 - Route piping to outside of structure. Continue with installation following instructions given in general guide lines for piping terminations and intake and exhaust piping terminations for direct vent sections. Refer to TABLE 13 for pipe sizes.

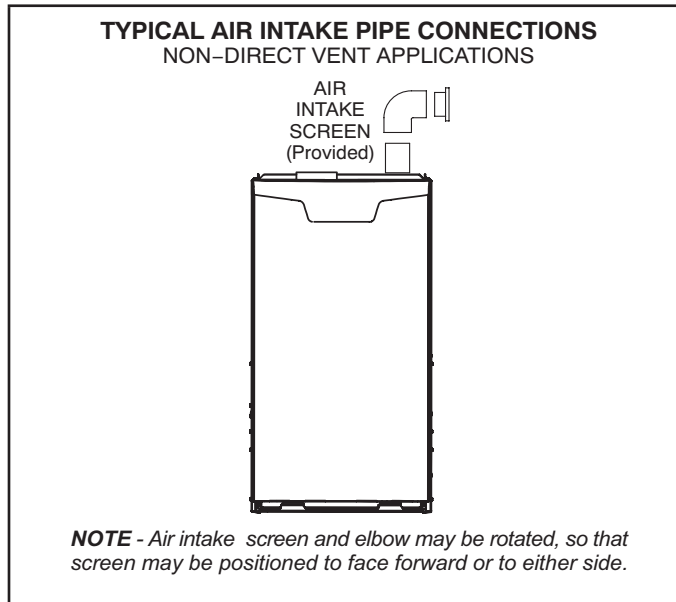

Follow the next two steps when installing the unit in Non-Direct Vent applications where combustion air is taken from indoors and flue gases are discharged outdoors.

- 1 - Use field-provided materials and the factory-provided air intake screen to route the intake piping as shown in FIGURE 27. Maintain a minimum clearance of 3" (76mm) around the air intake opening. The air intake opening (with the protective screen) should always be directed forward, or sideways.
- 2 - If intake air is drawn from a ventilated attic (FIGURE 28) or ventilated crawlspace (FIGURE 29) the exhaust vent length must not exceed those listed in TABLE 14. If 3" diameter pipe is used, reduce to 2" diameter pipe at the termination point to accommodate the debris screen.
- 3 - Use cement to secure the intake pipe to the connector, if desired.

**⚠ CAUTION**

**If this unit is being installed in an application with combustion air coming in from a space serviced by an exhaust fan, power exhaust fan, or other device which may create a negative pressure in the space, take care when sizing the inlet air opening. The inlet air opening must be sized to accommodate the maximum volume of exhausted air as well as the maximum volume of combustion air required for all gas appliances serviced by this space.**

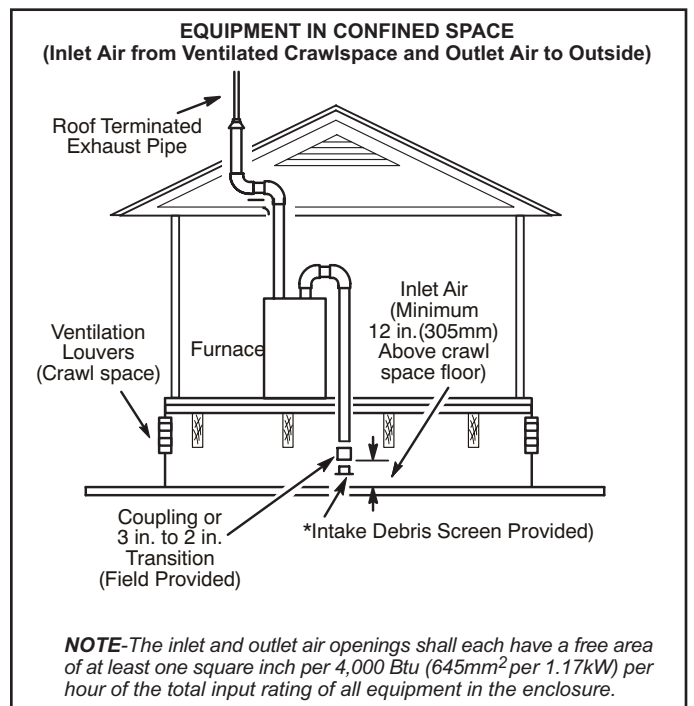
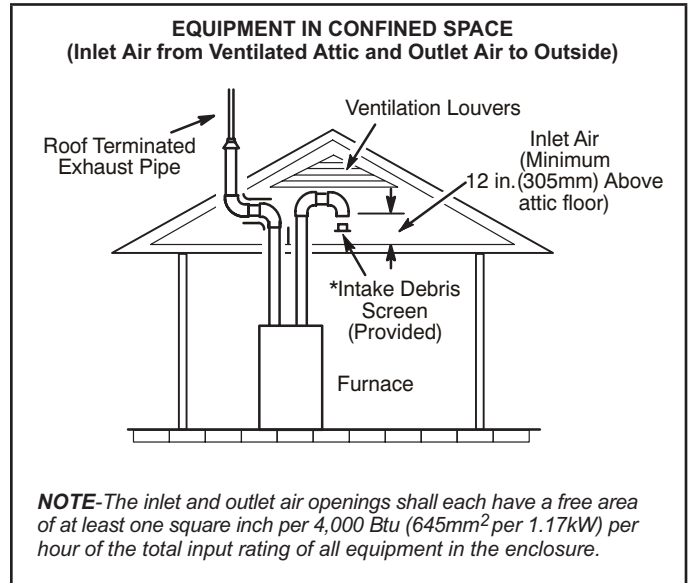

## General Guidelines for Vent Terminations

In Non-Direct Vent applications, combustion air is taken from indoors and the flue gases are discharged to the outdoors. The ML193DFE is then classified as a non-direct vent, Category IV gas furnace.

In Direct Vent applications, combustion air is taken from outdoors and the flue gases are discharged to the outdoors. The ML193DFE is then classified as a direct vent, Category IV gas furnace.

In both Non-Direct Vent and Direct Vent applications, the vent termination is limited by local building codes. In the absence of local codes, refer to the current National Fuel Gas Code ANSI Z223-1/NFPA 54 in U.S.A., and current CSAB149 Natural Gas and Propane Installation Codes in Canada for details.

Position termination according to location given in FIGURE 31 or FIGURE 32. In addition, position termination so it is free from any obstructions and 12" above the average snow accumulation. At vent termination, care must be taken to maintain protective coatings over building materials (prolonged exposure to exhaust condensate can destroy protective coatings). It is recommended that the exhaust outlet not be located within 6 feet (1.8m) of a condensing unit because the condensate can damage the painted coating.

**NOTE** - See TABLE 15 for maximum allowed exhaust pipe length without insulation in unconditioned space during winter design temperatures below 32°F (0°C). If required exhaust pipe should be insulated with 1/2" (13mm) Armaflex or equivalent. In extreme cold climate areas, 3/4" (19mm) Armaflex or equivalent may be necessary. Insulation must be protected from deterioration. Armaflex with UV protection is permissible. Basements or other enclosed areas that are not exposed to the outdoor ambient temperature and are above 32 degrees F (0°C) are to be considered conditioned spaces.

### IMPORTANT

Do not use screens or perforated metal in exhaust terminations. Doing so will cause freeze-ups and may block the terminations.

### IMPORTANT

**For Canadian Installations Only:**  
In accordance to CSA International B149 installation codes, the minimum allowed distance between the combustion air intake inlet and the exhaust outlet of other appliances shall not be less than 12 inches (305mm).

TABLE 15

Maximum Allowable Exhaust Vent Pipe Length (in ft.)<sup>3</sup> Without Insulation In Unconditioned Space For Winter Design Temperatures Single - Stage High Efficiency Furnace

Winter Design Temperatures <sup>1</sup> °F (°C)	Vent Pipe Diameter	Unit Input Size					
		045		070		090	
		PVC	<sup>2</sup> PP	PVC	<sup>2</sup> PP	PVC	<sup>2</sup> PP
32 to 21 (0 to -6)	1-1/2 in	25	N/A	20	N/A	N/A	N/A
	2 in	18	16	31	28	50	48
	2-1/2 in	13	N/A	24	N/A	42	N/A
	3 in	9	9	18	18	35	35
20 to 1 (-7 to -17)	1-1/2 in	15	N/A	20	N/A	N/A	N/A
	2 in	9	8	18	16	32	29
	2-1/2 in	5	N/A	13	N/A	24	N/A
	3 in	N/A	N/A	8	8	19	19
0 to -20 (-18 to -29)	1-1/2 in	10	N/A	15	N/A	N/A	N/A
	2 in	5	3	12	10	22	19
	2-1/2 in	N/A	N/A	7	N/A	15	N/A
	3 in	N/A	N/A	N/A	N/A	10	10

<sup>1</sup>Refer to 99% Minimum Design Temperature table provided in the current edition of the ASHRAE Fundamentals Handbook.

<sup>2</sup> Poly-Propylene vent pipe (PP) by Duravent and Centrotherm.

**NOTE** - Concentric terminations are the equivalent of 5' and should be considered when measuring pipe length.

**NOTE** - Maximum uninsulated vent lengths listed may include the termination (vent pipe exterior to the structure) and cannot exceed 5 linear feet or the maximum allowable intake or exhaust vent length listed in table 13 or 14 which ever is less.

**NOTE** - If insulation is required in an unconditioned space, it must be located on the pipe closest to the furnace. See FIGURE 30..

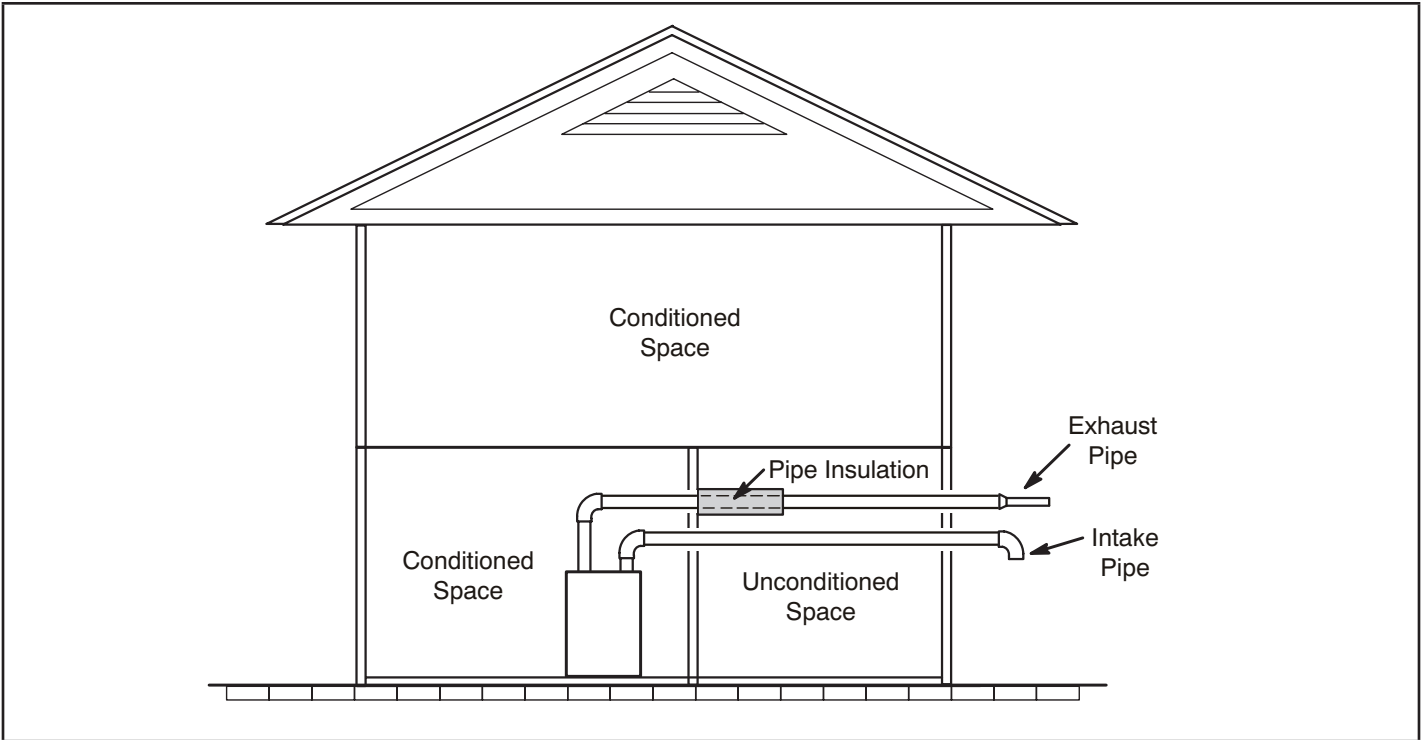

**FIGURE 30**

## VENT TERMINATION CLEARANCES FOR NON-DIRECT VENT INSTALLATIONS IN THE USA AND CANADA

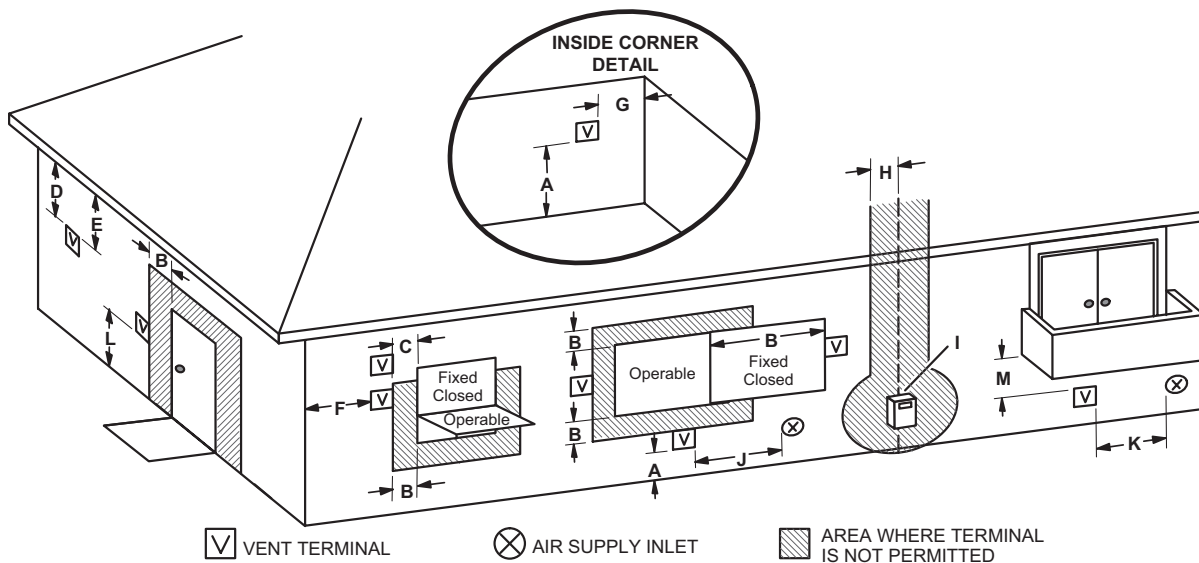

	US Installations <sup>1</sup>	Canadian Installations <sup>2</sup>
A =	Clearance above grade, veranda, porch, deck or balcony	12 inches (305mm) or 12 in. (305mm) above average snow accumulation.
B =	Clearance to window or door that may be opened	4 feet (1.2 m) below or to side of opening; 1 foot (30cm) above opening
C =	Clearance to permanently closed window	* 12"
D =	Vertical clearance to ventilated soffit located above the terminal within a horizontal distance of 2 feet (610 mm) from the center line of the terminal	* Equal to or greater than soffit depth.
E =	Clearance to unventilated soffit	* Equal to or greater than soffit depth.
F =	Clearance to outside corner	* No minimum to outside corner
G =	Clearance to inside corner	*
H =	Clearance to each side of center line extended above meter / regulator assembly	* 3 feet (.9m) within a height 15 feet (4.5m) above the meter / regulator assembly
I =	Clearance to service regulator vent outlet	* 3 feet (.9m)
J =	Clearance to non-mechanical air supply inlet to building or the combustion air inlet to any other appliance	4 feet (1.2 m) below or to side of opening; 1 foot (30 cm) above opening
K =	Clearance to mechanical air supply inlet	3 feet (.9m) above if within 10 feet (3m) horizontally
L =	Clearance above paved sidewalk or paved driveway located on public property	7 feet (2.1m)†
M =	Clearance under veranda, porch, deck or balcony	*12 inches (305mm)‡

<sup>1</sup> In accordance with the current ANSI Z223.1/NFPA 54 Natural Fuel Gas Code

<sup>2</sup> In accordance with the current CSA B149.1, Natural Gas and Propane Installation Code

† A vent shall not terminate directly above a sidewalk or paved driveway that is located between two single family dwellings and serves both dwellings.

‡ Permitted only if veranda, porch, deck or balcony is fully open on a minimum of two sides beneath the floor. Lennox recommends avoiding this location if possible.

\*For clearances not specified in ANSI Z223.1/NFPA 54 or CSA B149.1, clearance will be in accordance with local installation codes and the requirements of the gas supplier and these installation instructions."

**NOTE** - This figure is intended to illustrate clearance requirement and does not serve as a substitute for locally adopted installation codes.

**FIGURE 31**

## VENT TERMINATION CLEARANCES FOR DIRECT VENT INSTALLATIONS IN THE US AND CANADA

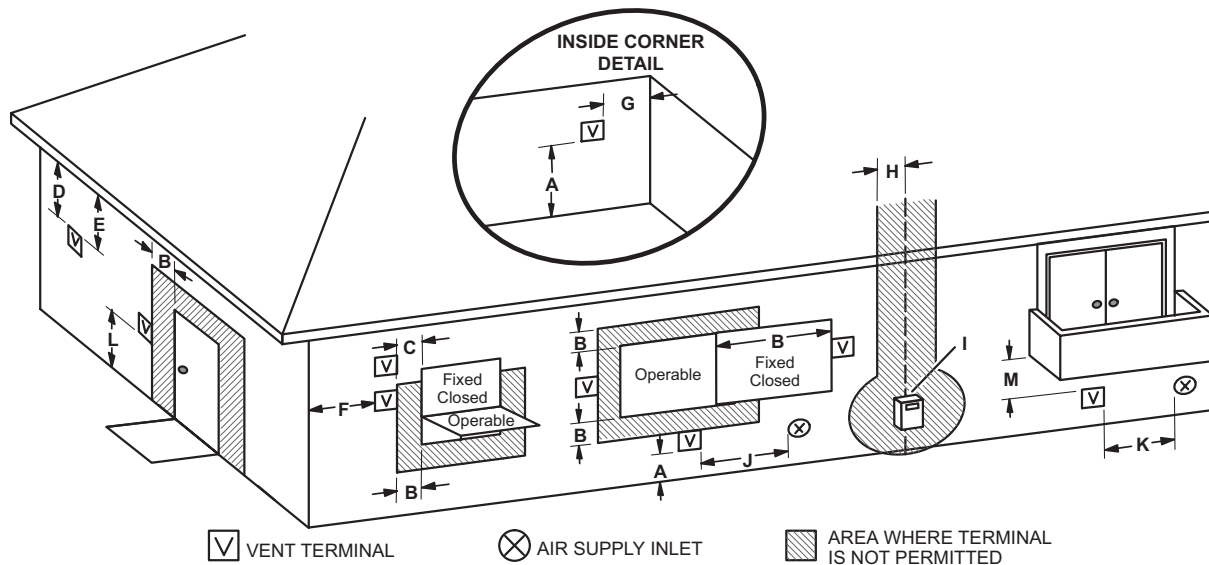

	US Installations <sup>1</sup>	Canadian Installations <sup>2</sup>	
A =	Clearance above grade, veranda, porch, deck or balcony	12 inches (305mm) or 12 in. (305mm) above average snow accumulation.	12 inches (305mm) or 12 in. (305mm) above average snow accumulation.
B =	Clearance to window or door that may be opened	6 inches (152mm) for appliances <10,000 Btuh (3kw), 9 inches (228mm) for appliances > 10,000 Btuh (3kw) and <50,000 Btuh (15 kw), 12 inches (305mm) for appliances > 50,000 Btuh (15kw)	6 inches (152mm) for appliances <10,000 Btuh (3kw), 12 inches (305mm) for appliances > 10,000 Btuh (3kw) and <100,000 Btuh (30kw), 36 inches (.9m) for appliances > 100,000 Btuh (30kw)
C =	Clearance to permanently closed window	* 12"	* 12"
D =	Vertical clearance to ventilated soffit located above the terminal within a horizontal distance of 2 feet (610mm) from the center line of the terminal	* Equal to or greater than soffit depth	* Equal to or greater than soffit depth
E =	Clearance to unventilated soffit	* Equal to or greater than soffit depth	* Equal to or greater than soffit depth
F =	Clearance to outside corner	* No minimum to outside corner	* No minimum to outside corner
G =	Clearance to inside corner	*	*
H =	Clearance to each side of center line extended above meter / regulator assembly	3 feet (.9m) within a height 15 feet (4.5m) above the meter / regulator assembly	3 feet (.9m) within a height 15 feet (4.5m) above the meter / regulator assembly
I =	Clearance to service regulator vent outlet	* 3 feet (.9m)	3 feet (.9m)
J =	Clearance to non-mechanical air supply inlet to building or the combustion air inlet to any other appliance	6 inches (152mm) for appliances <10,000 Btuh (3kw), 9 inches (228mm) for appliances > 10,000 Btuh (3kw) and <50,000 Btuh (15 kw), 12 inches (305mm) for appliances > 50,000 Btuh (15kw)	6 inches (152mm) for appliances <10,000 Btuh (3kw), 12 inches (305mm) for appliances > 10,000 Btuh (3kw) and <100,000 Btuh (30kw), 36 inches (.9m) for appliances > 100,000 Btuh (30kw)
K =	Clearance to mechanical air supply inlet	3 feet (.9m) above if within 10 feet (3m) horizontally	6 feet (1.8m)
L =	Clearance above paved sidewalk or paved driveway located on public property	* 7 feet (2.1m)	7 feet (2.1m)†
M =	Clearance under veranda, porch, deck or balcony	*12 inches (305mm)‡	12 inches (305mm)‡

<sup>1</sup> In accordance with the current ANSI Z223.1/NFPA 54 Natural Fuel Gas Code

<sup>2</sup> In accordance with the current CSA B149.1, Natural Gas and Propane Installation Code

† A vent shall not terminate directly above a sidewalk or paved driveway that is located between two single family dwellings and serves both dwellings.

‡ Permitted only if veranda, porch, deck or balcony is fully open on a minimum of two sides beneath the floor. Lennox recommends avoiding this location if possible.

\*For clearances not specified in ANSI Z223.1/NFPA 54 or CSA B149.1, clearance will be in accordance with local installation codes and the requirements of the gas supplier and these installation instructions."

**NOTE** - This figure is intended to illustrate clearance requirements and does not serve as a substitute for locally adopted installation codes.

**FIGURE 32**



## Details of Intake and Exhaust Piping Terminations for Direct Vent Installations

**NOTE** - In Direct Vent installations, combustion air is taken from outdoors and flue gases are discharged to outdoors.

**NOTE** - Flue gas may be slightly acidic and may adversely affect some building materials. If any vent termination is used and the flue gasses may impinge on the building material, a corrosion-resistant shield (minimum 24 inches square) should be used to protect the wall surface. If the optional tee is used, the protective shield is recommended. The shield should be constructed using wood, plastic, sheet metal or other suitable material. All seams, joints, cracks, etc. in the affected area should be sealed using an appropriate sealant. See FIGURE 40.

Intake and exhaust pipes may be routed either horizontally through an outside wall or vertically through the roof. In attic or closet installations, vertical termination through the roof is preferred. FIGURE 33 through FIGURE 41 show typical terminations.

1 - Intake and exhaust terminations are not required to be in the same pressure zone. You may exit the intake on one side of the structure and the exhaust on another side (FIGURE 33). You may exit the exhaust out the roof and the intake out the side of the structure (FIGURE 34).

2 - Intake and exhaust pipes should be placed as close together as possible at termination end (refer to illustrations). Maximum separation is 3" (76mm) on roof terminations and 6" (152mm) on side wall terminations.

**NOTE** - When venting in different pressure zones, the maximum separation requirement of intake and exhaust pipe DOES NOT apply.

3 - On roof terminations, the intake piping should terminate straight down using two 90° elbows (FIGURE 35).

4 - Exhaust piping must terminate straight out or up as shown. A reducer may be required on the exhaust piping at the point where it exits the structure to improve the velocity of exhaust away from the intake piping. See TABLE 16.

**TABLE 16**

EXHAUST PIPE TERMINATION SIZE REDUCTION

ML193 Model	Exhaust Pipe Size	Termination Pipe Size
*045 and 070	2" (51mm), 2-1/2" (64mm), 3" (76mm)	1-1/2" (38mm)
*090		2" (51mm)

\*ML193DFE-045, -070 and -090 units with the flush-mount termination must use the 1-1/2" accelerator supplied with the kit.

5 - On field-supplied terminations for side wall exit, exhaust piping may extend a maximum of 12 inches (305mm) for 2" PVC and 20 inches (508mm) for 3" (76mm) PVC beyond the outside wall. Intake piping should be as short as possible. See FIGURE 40.

**NOTE** - Care must be taken to avoid recirculation of exhaust back into intake pipe.

6 - On field supplied terminations, a minimum distance between the end of the exhaust pipe and the end of the intake pipe without a termination elbow is 8" and a minimum distance of 6" with a termination elbow. See FIGURE 40.

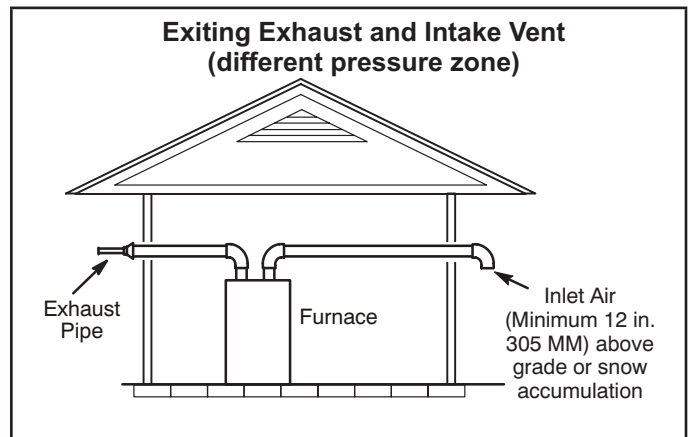

**FIGURE 33**

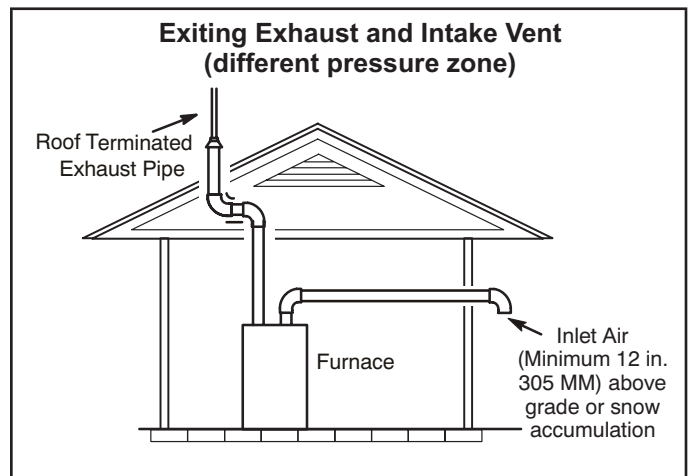

**FIGURE 34**

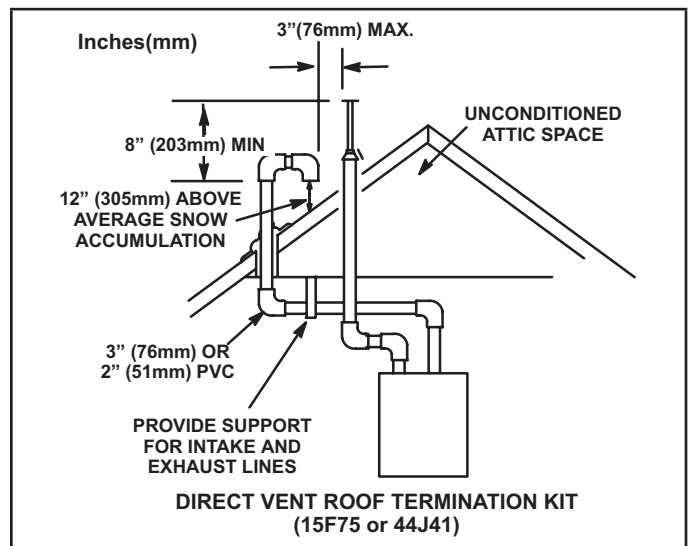

**FIGURE 35**

- 7 - If intake and exhaust piping must be run up a side wall to position above snow accumulation or other obstructions, piping must be supported. At least one bracket must be used within 6" from the top of the elbow and then every 24" (610mm) as shown in FIGURE 40, to prevent any movement in any direction. When exhaust and intake piping must be run up an outside wall, the exhaust piping must be terminated with pipe sized per table 10. The intake piping may be equipped with a 90° elbow turnaround. Using turnaround will add 5 feet (1.5m) to the equivalent length of the pipe.
- 8 - A multiple furnace installation may use a group of up to four terminations assembled together horizontally, as shown in FIGURE 38.

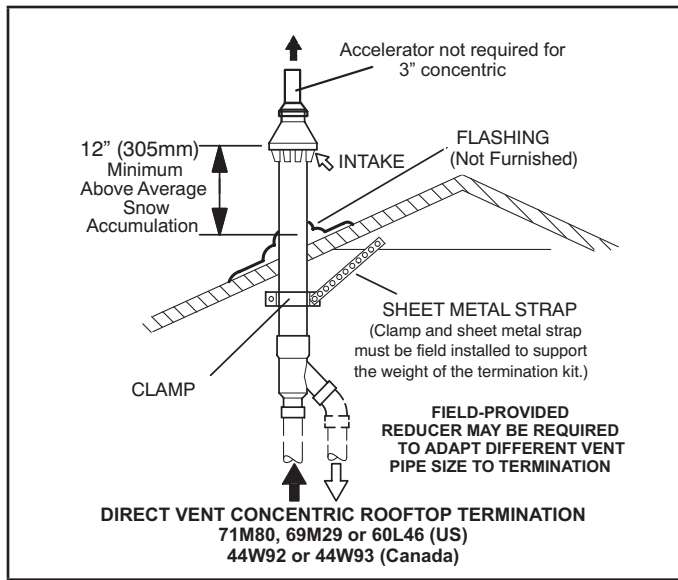

FIGURE 36

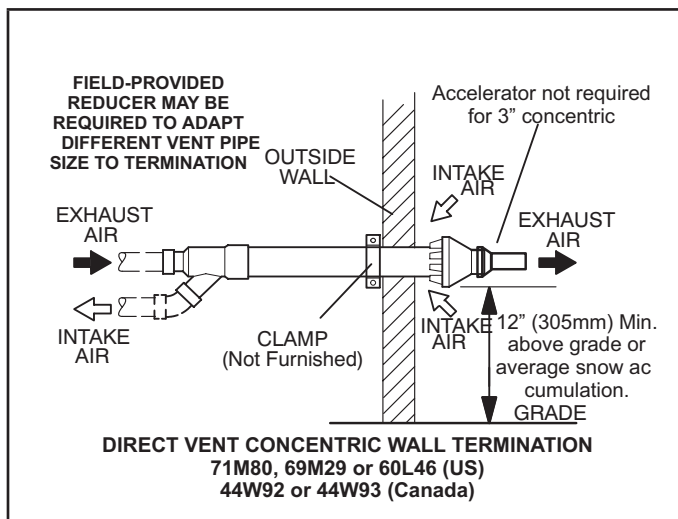

FIGURE 37

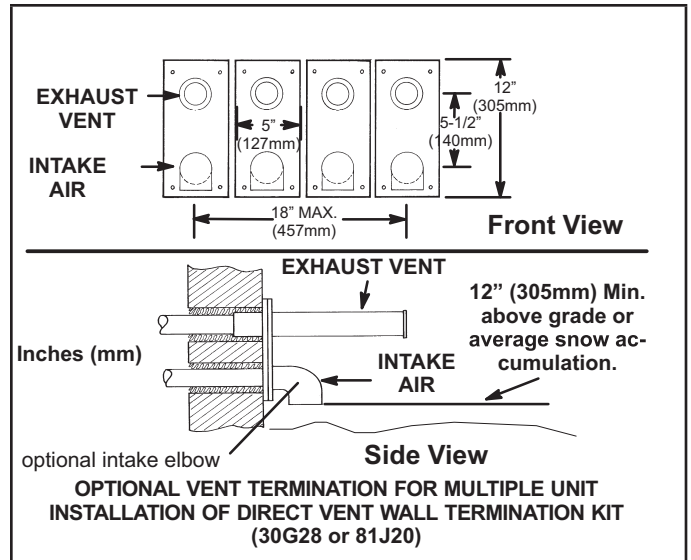

FIGURE 38

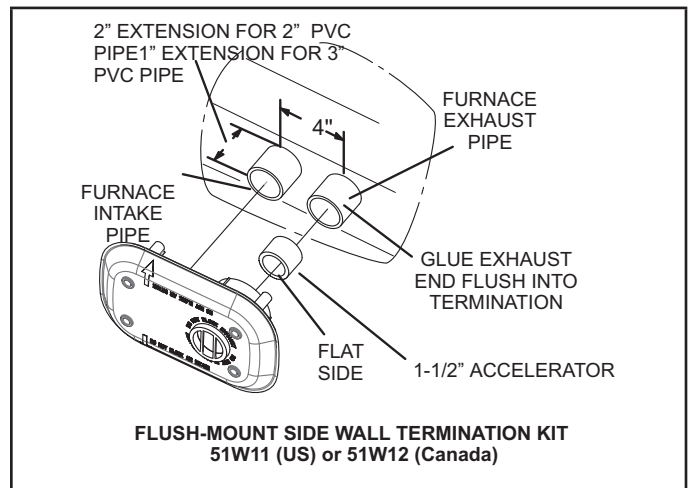
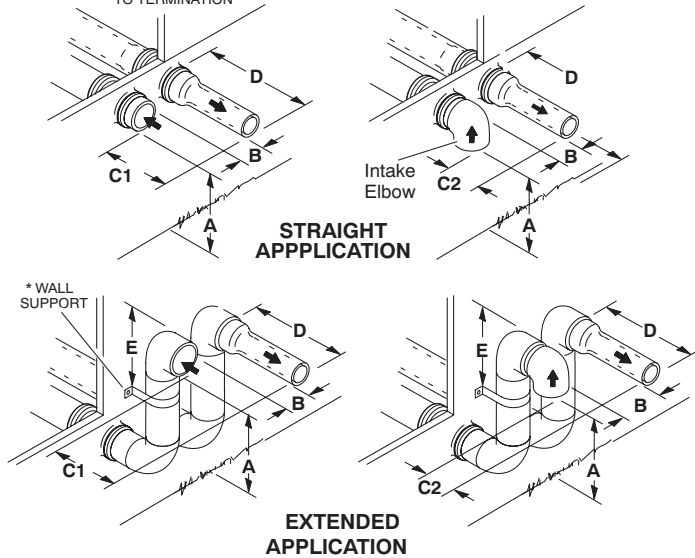

FIGURE 39

NOTE - FIELD-PROVIDED REDUCER MAY BE REQUIRED TO ADAPT LARGER VENT PIPE SIZE TO TERMINATION

### FIELD FABRICATED WALL TERMINATION



	2" (51mm) Vent Pipe	3" (76mm) Vent Pipe
<b>A</b> - Minimum clearance above grade or average snow accumulation	12" (305 mm)	12" (305 mm)
<b>B</b> - Maximum horizontal separation between intake and exhaust	6" (152 mm)	6" (152 mm)
<b>C1</b> - Minimum from end of exhaust to inlet of intake	8" (203 mm)	8" (203 mm)
<b>C2</b> - Minimum from end of exhaust to inlet of intake	6" (152 mm)	6" (152 mm)
<b>D</b> - Maximum exhaust pipe length	12" (305 mm)	20" (508 mm)
<b>E</b> - Maximum wall support distance from top of each pipe (intake/exhaust)	6" (152 mm)	6" (152 mm)

See maximum allowable venting tables for venting lengths with this arrangement.

\* Use wall support every 24" (610 mm). Use two wall supports if extension is greater than 24" (610 mm) but less than 48" (1219 mm).

NOTE - One wall support must be within 6" (152 mm) from top of each pipe (intake and exhaust) to prevent movement in any direction.

### ALTERNATE TERMINATIONS (TEE & FORTY-FIVE DEGREE ELBOWS ONLY)

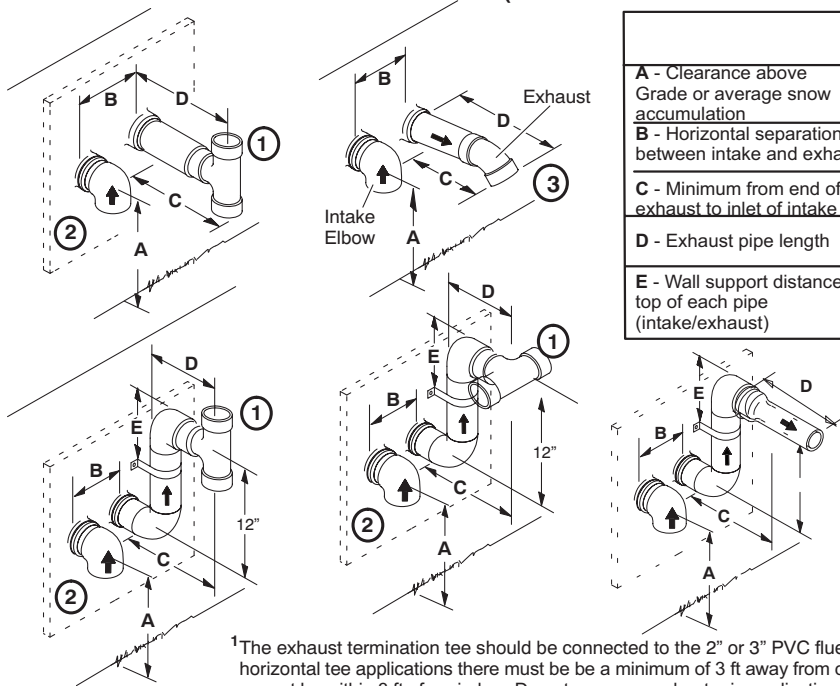

	2" (51mm) Vent Pipe	3" (76mm) Vent Pipe
<b>A</b> - Clearance above Grade or average snow accumulation	12" (305 mm) Min	12" (305 mm) Min
<b>B</b> - Horizontal separation between intake and exhaust	6" (152mm)min 24" (610mm )Max	6" (152mm)min 24" (610mm )Max
<b>C</b> - Minimum from end of exhaust to inlet of intake	9" (227mm)	9" (227mm)
<b>D</b> - Exhaust pipe length	12" (305mm)min 16" (405mm )Max	12" (305mm)min 16" (405mm )Max
<b>E</b> - Wall support distance from top of each pipe (intake/exhaust)	6" (152mm) Max	6" (152mm) Max

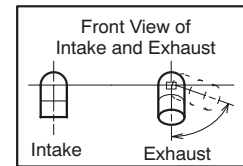

<sup>1</sup>The exhaust termination tee should be connected to the 2" or 3" PVC flue pipe as shown in the illustration. In horizontal tee applications there must be a minimum of 3 ft away from covered patios or any living areas and cannot be within 3 ft of a window. Do not use an accelerator in applications that include an exhaust termination tee. The accelerator is not required.

<sup>2</sup>As required. Flue gas may be acidic and may adversely affect some building materials. If a side wall vent termination is used and flue gases will impinge on the building materials, a corrosion-resistant shield (24 inches square) should be used to protect the wall surface. If optional tee is used, the protective shield is recommended. The shield should be constructed using wood, sheet metal or other suitable material. All seams, joints, cracks, etc. in affected area, should be sealed using an appropriate sealant.

<sup>3</sup>Exhaust pipe 45° elbow can be rotated to the side away from the combustion air inlet to direct exhaust away from adjacent property. The exhaust must never be directed toward the combustion air inlet.

FIGURE 40

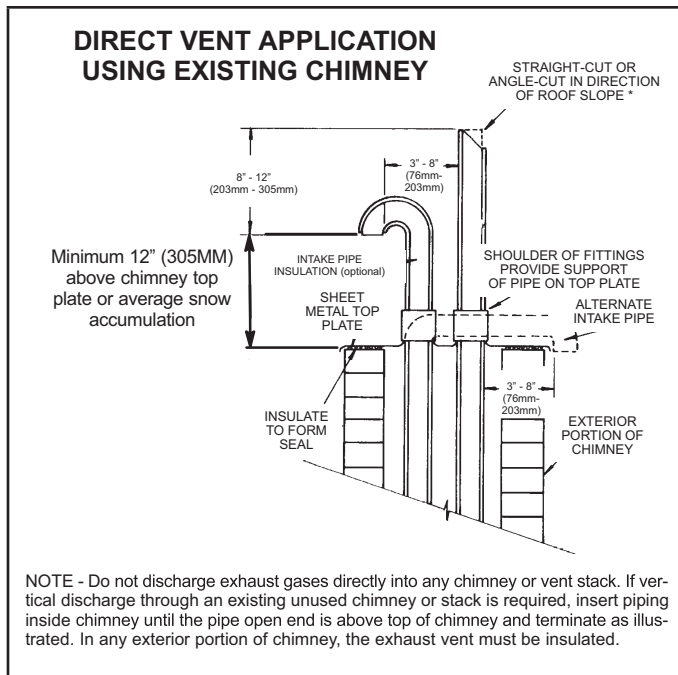
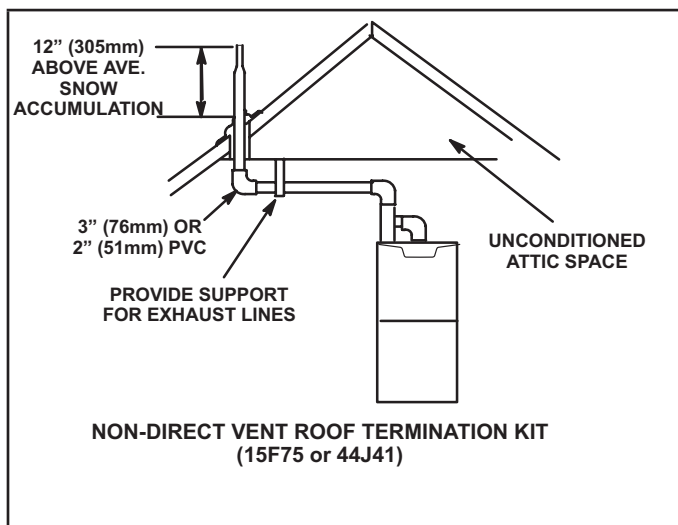

**FIGURE 41**

### Details of Exhaust Piping Terminations for Non-Direct Vent Applications

Exhaust pipes may be routed either horizontally through an outside wall or vertically through the roof. In attic or closet installations, vertical termination through the roof is preferred. FIGURE 42 and FIGURE 43 show typical terminations.

- 1 - Exhaust piping must terminate straight out or up as shown. The termination pipe must be sized as listed in TABLE 16. The specified pipe size ensures proper velocity required to move the exhaust gases away from the building.



**FIGURE 42**

- 2 - On field supplied terminations for side wall exit, exhaust piping may extend a maximum of 12 inches (305mm) for 2" PVC and 20 inches (508mm) for 3" (76mm) PVC beyond the outside wall.
- 3 - If exhaust piping must be run up a side wall to position above snow accumulation or other obstructions, piping must be supported every 24 inches (610mm). When exhaust piping must be run up an outside wall, any reduction in exhaust pipe size must be done after the final elbow.
- 4 - Distance between exhaust pipe terminations on multiple furnaces must meet local codes.

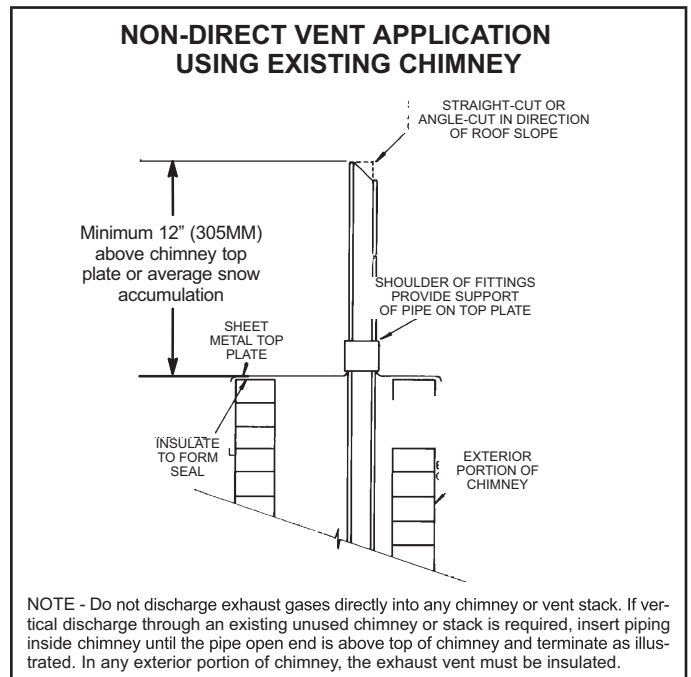
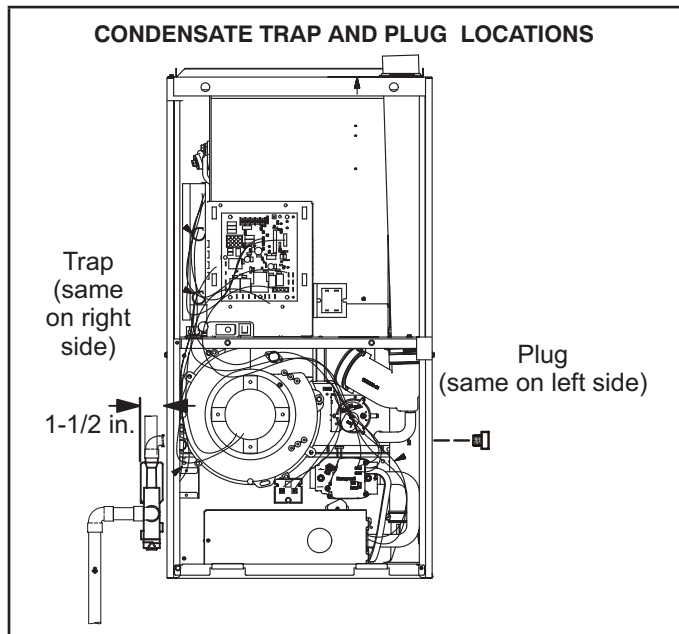

**FIGURE 43**

## Condensate Piping

This unit is designed for either right- or left-side exit of condensate piping. Refer to FIGURE 44 and FIGURE 46 for condensate trap locations.

**NOTE** - If necessary the condensate trap may be installed up to 5' away from the furnace. Use PVC pipe to connect trap to furnace condensate outlet. Piping from furnace must slope down a minimum of 1/4" per ft. toward trap.



**FIGURE 44**

- 1 - Determine which side condensate piping will exit the unit, location of trap, field-provided fittings and length of PVC pipe required to reach available drain.
- 2 - Use a large flat head screw driver or a 1/2" drive socket extension and remove plug (FIGURE 44) from the cold end header box at the appropriate location on the side of the unit. Install provided 3/4 NPT street elbow fitting into cold end header box. Use Teflon tape or appropriate pipe dope.
 

**NOTE** - Cold end header box drain plugs are factory installed. Check the unused plug for tightness to prevent leakage.
- 3 - Install the cap over the clean out opening at the base of the trap. Secure with clamp. See FIGURE 50.
- 4 - Install drain trap using appropriate PVC fittings, glue all joints. Glue the provided drain trap as shown in FIGURE 50. Route the condensate line to an open drain.
- 5 - FIGURE 48 shows the furnace and evaporator coil using a separate drain. If necessary, the condensate line from the furnace and evaporator coil can drain together. See FIGURE 49. The field provided vent must be a minimum 1" to a maximum 2" length above the condensate drain outlet connection.
- 6 - If unit will be started immediately upon completion of installation, prime trap per procedure outlined in Unit Start-Up section.

**NOTE** - If necessary the condensate trap may be installed up to 5 feet away from the furnace. Piping from furnace must slope down a minimum of 1/4" per ft. toward trap.

**NOTE** - Appropriately sized tubing and barbed fitting may be used for condensate drain. Attach to the drain on the trap using a hose clamp. See FIGURE 45.

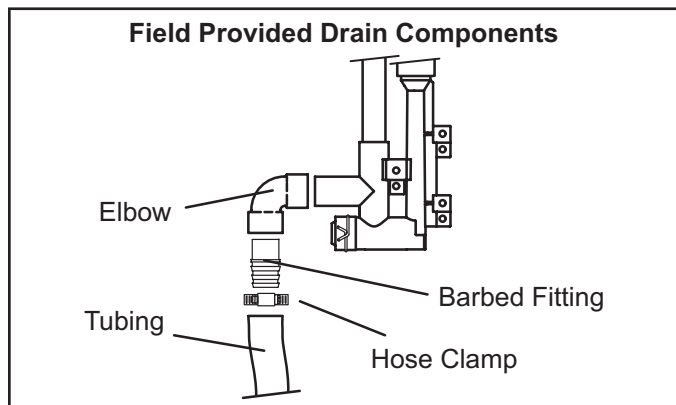

**FIGURE 45**

Condensate line must slope downward away from the trap to drain. If drain level is above condensate trap, condensate pump must be used. Condensate drain line should be routed within the conditioned space to avoid freezing of condensate and blockage of drain line. If this is not possible, a heat cable kit may be used on the condensate trap and line. Heat cable kit is available from Lennox in various lengths; 6 ft. (1.8m) - kit no. 26K68 and 24 ft. (7.3m) - kit no. 26K69.

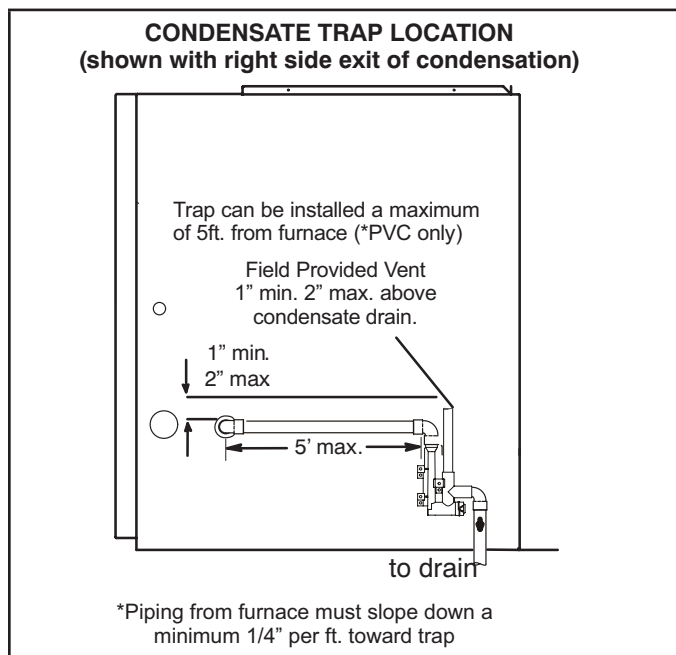

**FIGURE 46**

## **!** CAUTION

Do not use copper tubing or existing copper condensate lines for drain line.

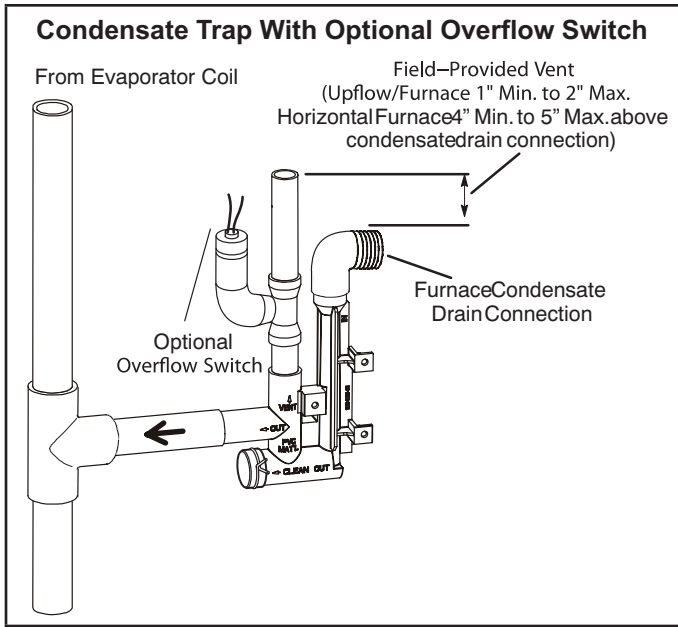

**FIGURE 47**

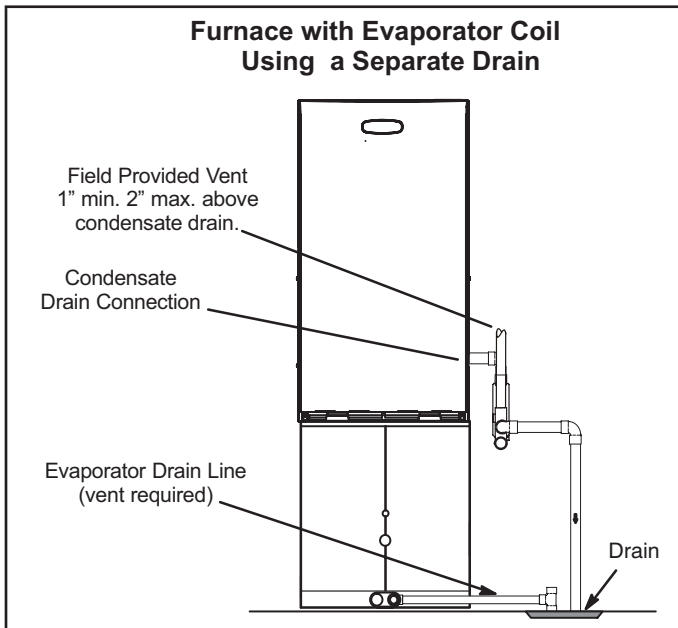

**FIGURE 48**

**! IMPORTANT**

**When combining the furnace and evaporator coil drains together, the A/C condensate drain outlet must be vented to relieve pressure in order for the furnace pressure switch to operate properly.**

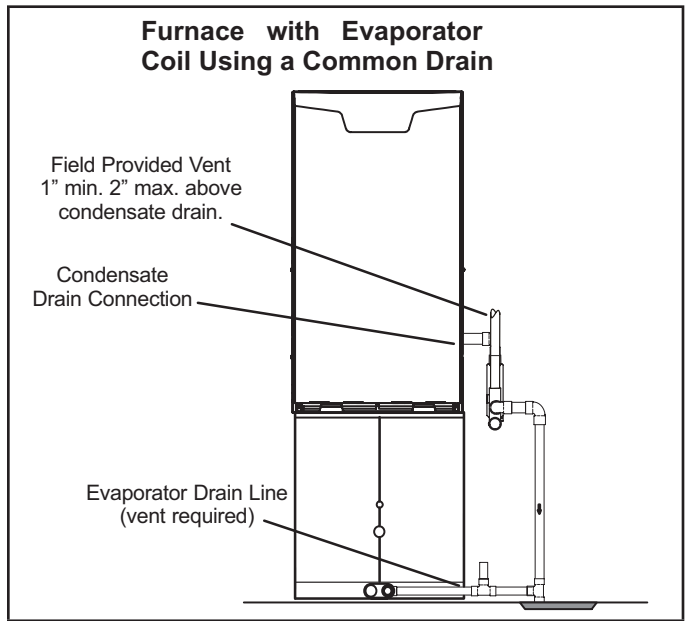

**FIGURE 49**

**TRAP / DRAIN ASSEMBLY USING 1/2" PVC OR 3/4" PVC**

**Optional Condensate Drain Connection**

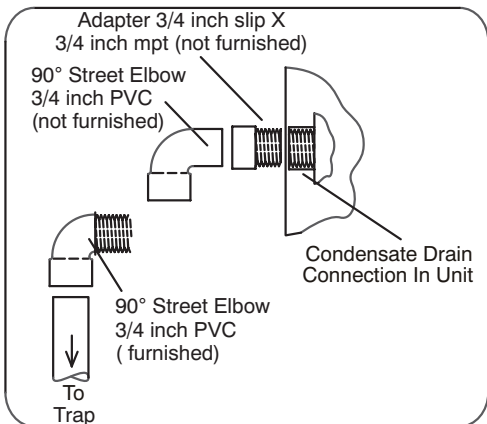

**Optional Drain Piping From Trap**

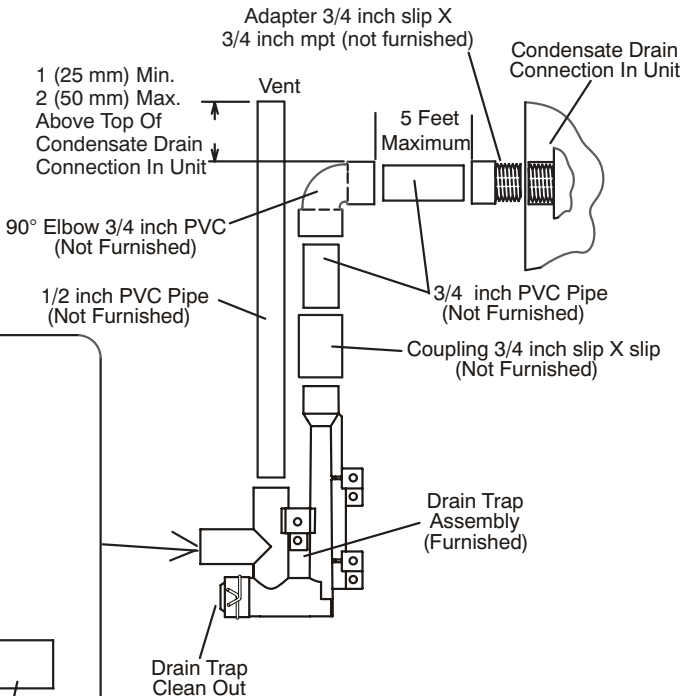
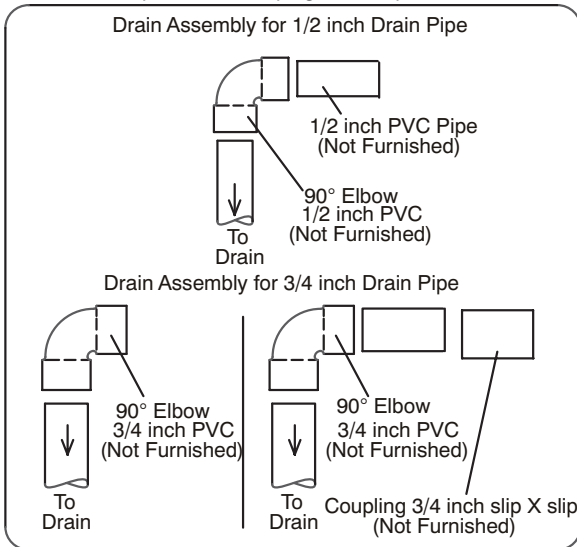

**Drain Trap Assembly with 1/2 inch Piping**

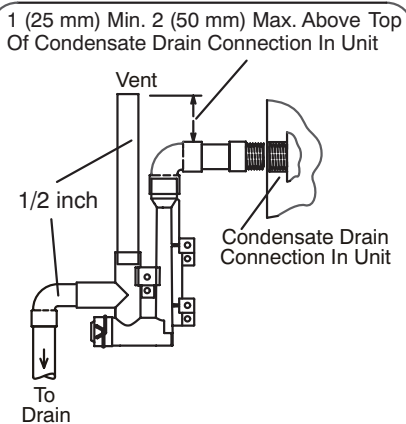

**Drain Trap Assembly with 3/4 inch Piping**

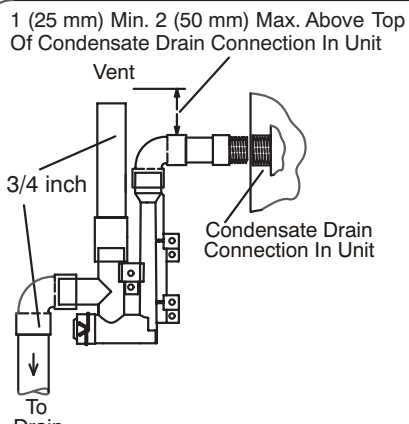

**Drain Trap Assembly (Furnished)**

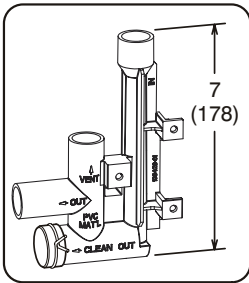

**FIGURE 50**

### III-START-UP

#### A-Preliminary and Seasonal Checks

- 1 - Inspect electrical wiring, both field and factory installed for loose connections. Tighten as required.
- 2 - Check voltage at disconnect switch. Voltage must be within range listed on the nameplate. If not, consult the power company and have voltage condition corrected before starting unit.
- 3 - Inspect condition of condensate traps and drain assembly. Disassemble and clean seasonally.

#### B-Heating Start-Up

**BEFORE LIGHTING** the unit, smell all around the furnace area for gas. Be sure to smell next to the floor because some gas is heavier than air and will settle on the floor.

The gas valve on the ML193DFE is equipped with a gas control switch. Use only your hand to move the switch.

Never use tools. If the the switch will not move by hand, replace the valve. Do not try to repair it. Force or attempted repair may result in a fire or explosion.

#### Placing the furnace into operation:

ML193DFE units are equipped with a SureLight ignition system. Do not attempt to manually light burners on this furnace. Each time the thermostat calls for heat, the burners will automatically light. The ignitor does not get hot when there is no call for heat on units with SureLight ignition system.

#### Priming Condensate Trap

The condensate trap should be primed with water prior to start-up to ensure proper condensate drainage. Either pour 10 fl. oz. (300 ml) of water into the trap, or follow these steps to prime the trap:

- 1 - Follow the lighting instructions to place the unit into operation.
- 2 - Set the thermostat to initiate a heating demand.
- 3 - Allow the burners to fire for approximately 3 minutes.
- 4 - Adjust the thermostat to deactivate the heating demand.
- 5 - Wait for the combustion air inducer to stop. Set the thermostat to initiate a heating demand and again allow the burners to fire for approximately 3 minutes.
- 6 - Adjust the thermostat to deactivate the heating demand and again wait for the combustion air inducer to stop. At this point, the trap should be primed with sufficient water to ensure proper condensate drain operation.

## **⚠ WARNING**

**If you do not follow these instructions exactly, a fire or explosion may result causing property damage, personal injury or death.**

#### Gas Valve Operation (FIGURE 51)

- 1 - **STOP!** Read the safety information at the beginning of this section.

- 2 - Set the thermostat to the lowest setting.
- 3 - Turn off all electrical power to the unit.
- 4 - This furnace is equipped with an ignition device which automatically lights the burners. Do **not** try to light the burners by hand.
- 5 - Remove the outer access panel.
- 6 - Move gas valve switch to **OFF**. See FIGURE 51.
- 7 - Wait five minutes to clear out any gas. If you then smell gas, **STOP!** Immediately call your gas supplier from a neighbor's phone. Follow the gas supplier's instructions. If you do not smell gas go to next step.
- 8 - Move gas valve switch to ON. See FIGURE 51.

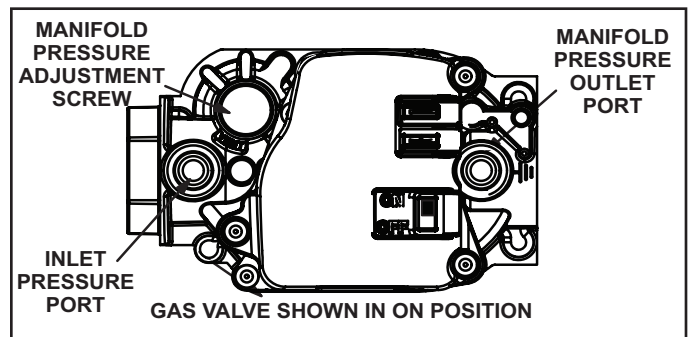

**FIGURE 51**

- 9 - Replace the upper outer access panel.
  - 10 - Turn on all electrical power to the unit.
  - 11 - Set the thermostat to desired setting.
- NOTE** - When unit is initially started, steps 1 through 11 may need to be repeated to purge air from gas line.
- 12 - If the appliance will not operate, follow the instructions "Turning Off Gas to Unit" and call your service technician or gas supplier.

#### Turning Off Gas to Unit

- 1 - Set the thermostat to the lowest setting.
- 2 - Turn off all electrical power to the unit if service is to be performed.
- 3 - Remove the outer access panel.
- 4 - Move gas valve switch to **OFF**.
- 5 - Replace the outer access panel.

#### Failure To Operate

If the unit fails to operate, check the following:

- 1 - Is the thermostat calling for heat?
- 2 - Are access panels securely in place?
- 3 - Is the main disconnect switch closed?
- 4 - Is there a blown fuse or tripped breaker?
- 5 - Is the filter dirty or plugged? Dirty or plugged filters will cause the limit control to shut the unit off.
- 6 - Is gas turned on at the meter?
- 7 - Is the manual main shut-off valve open?
- 8 - Is the internal manual shut-off valve open?
- 9 - Is the unit ignition system in lockout? If the unit locks out again, inspect the unit for blockages.



## IV-HEATING SYSTEM SERVICE CHECKS

### A-C.S.A. Certification

All units are C.S.A. design certified without modifications. Refer to the ML193DFE Operation and Installation Instruction Manual Information.

### B-Gas Piping

#### **! IMPORTANT**

If a flexible gas connector is required or allowed by the authority that has jurisdiction, black iron pipe shall be installed at the gas valve and extend outside the furnace cabinet. The flexible connector can then be added between the black iron pipe and the gas supply line.

#### **! WARNING**

Do not over torque (800 in-lbs) or under torque (350 in-lbs) when attaching the gas piping to the gas valve.

Gas supply piping should not allow more than 0.5"W.C. drop in pressure between gas meter and unit. Supply gas pipe must not be smaller than unit gas connection.

Compounds used on gas piping threaded joints should be resistant to action of liquefied petroleum gases.

### C-Testing Gas Piping

#### **! IMPORTANT**

In case emergency shutdown is required, turn off the main shut-off valve and disconnect the main power to unit. These controls should be properly labeled by the installer.

When pressure testing gas lines, the gas valve must be disconnected and isolated. Gas valves can be damaged if subjected to more than 0.5psig (14" W.C.). See FIGURE 52.

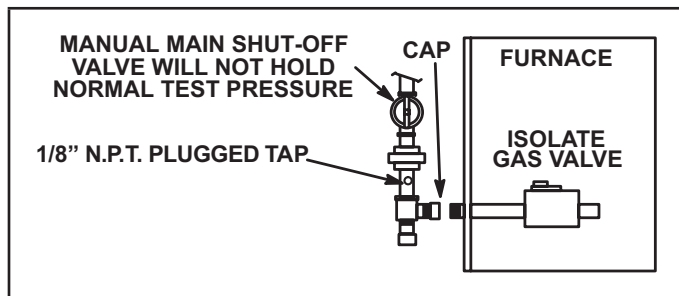

FIGURE 52

When checking piping connections for gas leaks, use preferred means. Kitchen detergents can cause harmful corrosion on various metals used in gas piping. Use of a specialty Gas Leak Detector is strongly recommended. It is available through Lennox under part number 31B2001. See Corp. 8411-L10, for further details.

#### **! WARNING**

Do not use matches, candles, flame or any other source of ignition to check for gas leaks.

### D-Testing Gas Supply Pressure

When testing supply gas pressure, use the 1/8" N.P.T. plugged tap or pressure post located on the gas valve to facilitate test gauge connection. See FIGURE 51. Check gas line pressure with unit firing at maximum rate. Low pressure may result in erratic operation or underfire. High pressure can result in permanent damage to gas valve or overfire.

On multiple unit installations, each unit should be checked separately, with and without units operating. Supply pressure must fall within range listed in TABLE 19.

### E-Check Manifold Pressure

After line pressure has been checked and adjusted, check manifold pressure. Move pressure gauge to outlet pressure tap located on unit gas valve (GV1).

Checks of manifold pressure are made as verification of proper regulator adjustment.

#### **! CAUTION**

For safety, connect a shut-off valve between the manometer and the gas tap to permit shut off of gas pressure to the manometer.

Follow the steps below and use FIGURE 53 as a reference. Gas manifold Kit 10L34 provides additional components if needed.

- 1 - Connect the test gauge positive side "+" to manifold pressure tap on gas valve.
- 2 - Tee into the gas valve regulator vent hose and connect to test gauge negative "-".
- 3 - Start unit and let run for 5 minutes to allow for steady state conditions.
- 4 - After allowing unit to stabilize for 5 minutes, record manifold pressure and compare to value given in TABLE 19.
- 5 - Shut unit off and remove manometer as soon as an accurate reading has been obtained. Take care to replace pressure tap plug.
- 6 - Start unit and perform leak check. Seal leaks if found.

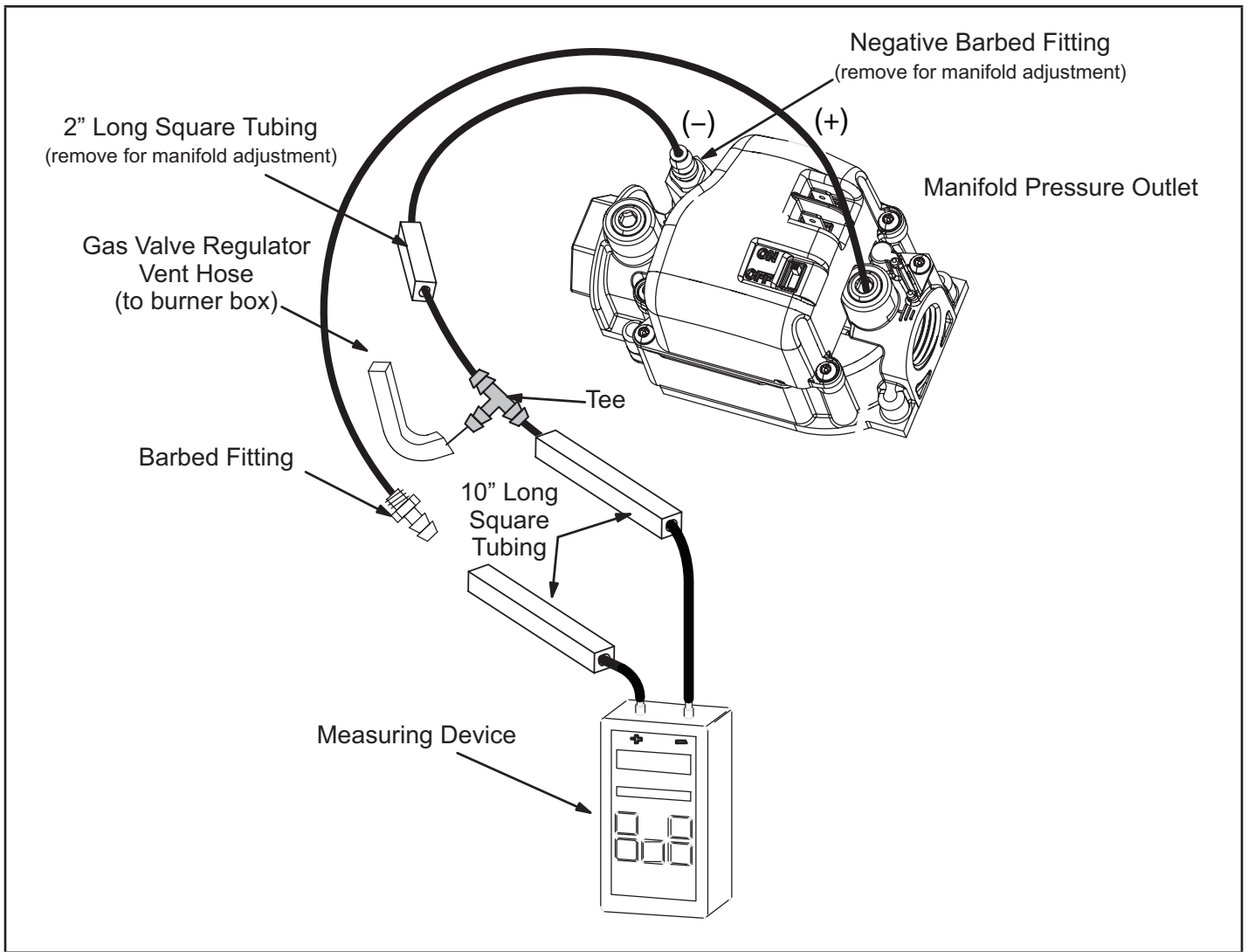

**FIGURE 53**

## F- Proper Gas Flow (Approximate)

**TABLE 17**

GAS METER CLOCKING CHART				
ML196 Unit	Seconds For One Revolution			
	Natural		LP/Propane	
	1 cu ft Dial	2 cu ft Dial	1 cu ft Dial	2 cu ft Dial
-045	80	160	200	400
-070	55	110	136	272
-090	41	82	102	204
Natural-1000 btu/cu ft LP-2500 btu/cu ft				

**NOTE** - To obtain accurate reading, shut off all other gas appliances connected to meter.

Furnace should operate at least 5 minutes before checking gas flow. Determine time in seconds for two revolutions of gas through the meter. (Two revolutions assures a more accurate time). Divide by two and compare to time in TABLE 17. If manifold pressure matches TABLE 19 and rate is incorrect, check gas orifices for proper size and restriction. Remove temporary gas meter if installed.

## G- Proper Combustion

Furnace should operate at least 15 minutes with correct manifold pressure and gas flow rate before checking combustions. Take sample beyond the flue outlet and compare to TABLE 18. **The maximum carbon monoxide reading should not exceed 100 ppm.**

**TABLE 18**

ML193 Unit	CO <sub>2</sub> % Nat	CO <sub>2</sub> % LP
-045	7.0 - 9.0	8.0 - 10.0
-070		
-090		

## H- High Altitude

**NOTE** - In Canada, certification for installations at elevations over 4500 feet (1372 m) is the jurisdiction of local authorities.

Units may be installed at altitudes up to 10,000 ft. Above sea level. See TABLE 19 for de-rate manifold values. Units installed at altitude of 7501 - 10,000 feet require an orifice change. Units installed at altitude of 4501 - 10,000 feet require a pressure switch change which can be ordered separately. TABLE 20 lists conversion kit and pressure switch requirements at varying altitudes.

**NOTE** - A natural to LP/propane gas changeover kit is necessary to convert this unit. Refer to the changeover kit installation instruction for the conversion procedure.

**TABLE 19**

**Manifold and Supply Line Pressure 0-10,000ft.**

ML193 Unit	Gas	Manifold Pressure in. wg.					Supply Line Pressure in. w.g. 0 - 10000 ft.	
		0 - 4500 ft	4501 - 5500 ft	5501 - 6500 ft	6501 - 7500 ft	7501 - 10,000 ft		
All Models	Natural	3.5	3.3	3.2	3.1	3.5	4.5	13.0
	L.P. Propane	10.0	9.4	9.1	8.9	10.0	11.0	13.0

NOTE - A natural to L.P. propane gas changeover kit is necessary to convert this unit. Refer to the changeover kit installation instruction for the conversion procedure.

**TABLE 20**

**Conversion Kit and Pressure Switch Requirements at Varying Altitudes**

ML193 Unit	Natural to LP/Propane	High Altitude Natural Burner Orifice Kit	LP/Propane to Natural	High Altitude LP/Propane Burner Orifice Kit	High Altitude Pressure Switch	
	0 - 7500 ft (0 - 2286m)	7501 - 10,000 ft (2286 - 3038m)	0 - 7500 ft (0 - 2286m)	7501 - 10,000 ft (2286 - 3038m)	4501 - 7500 ft (1373 - 2286m)	7501 - 10,000 ft (2286 - 3048m)
-045	*11K49	73W37	*73W81	11K44	11U65	11U66
-070						
-090						

\*Conversion requires installation of a gas valve manifold spring which is provided with the gas conversion kit. Pressure switch is factory set. No adjustment necessary. All models use the factory-installed pressure switch from 0-4500 feet (0-1370 m).

## I- Proper Ground and Voltage

A poorly grounded furnace can contribute to premature ignitor failure. Use the following procedure to check for ground and voltage to the integrated control.

- 1 - Measure the AC voltage between Line Neutral (spade terminals) and "C" terminal (low voltage terminal block) on the integrated control. See FIGURE 54. A wide variation in the voltage between Line Neutral and "C" as a function of load indicates a poor or partial ground. Compare the readings to the table below. If the readings exceed the maximum shown in TABLE 21, make repairs before operating the furnace

- 2 - In addition, measure the AC voltage from Line Hot to Line Neutral (spade terminals) on the integrated control. See FIGURE 54. This voltage should be in the range of 97 to 132 Vac.

**Note** - FIGURE 54 is a typical ignition control illustration.

**TABLE 21**

Furnace Status	Measurement VAC	
	Expected	Maximum
Power On Furnace Idle	0.3	2
CAI / Ignitor Energized	0.75	5
Indoor Blower Energized	Less than 2	10

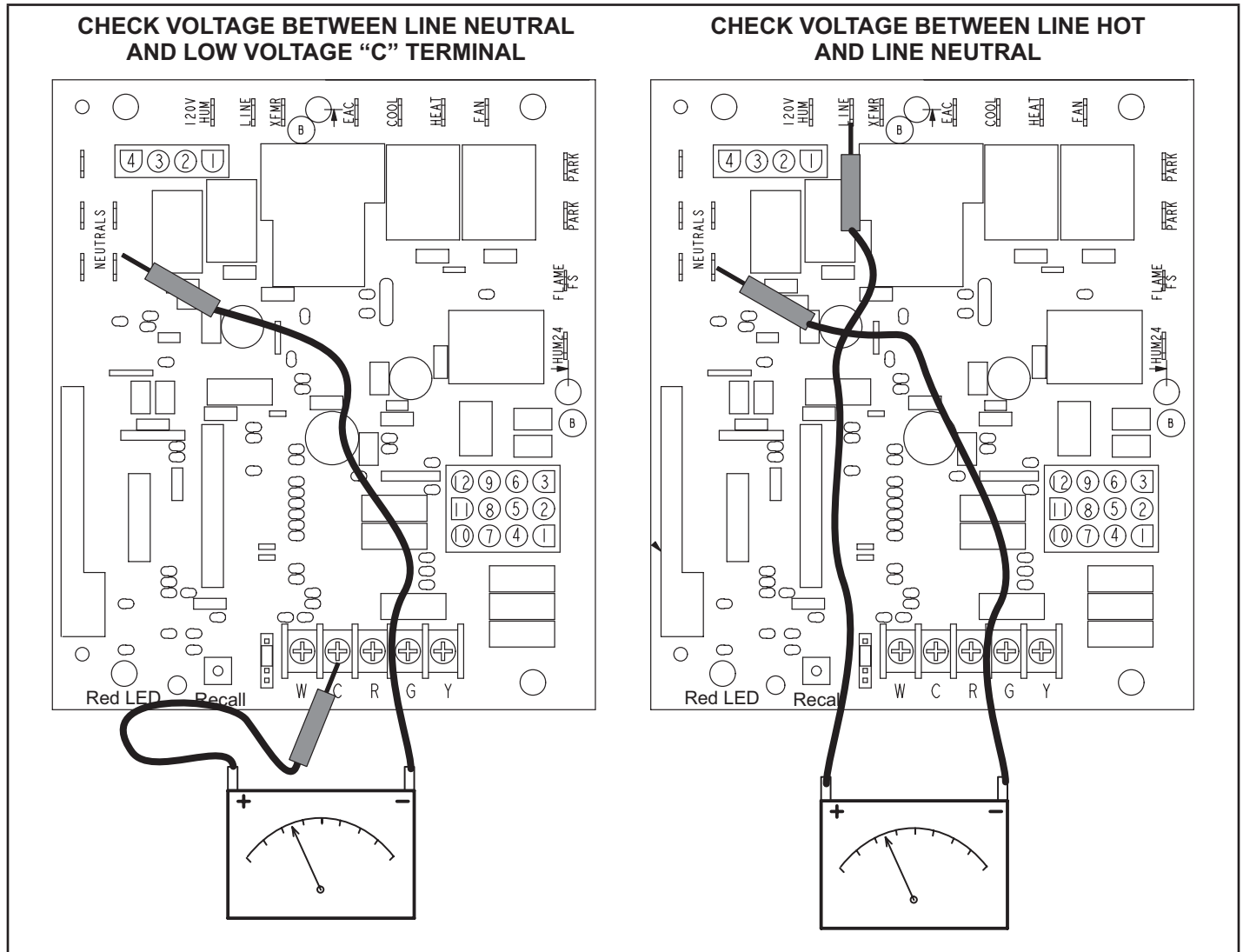

**FIGURE 54**

## V-TYPICAL OPERATING CHARACTERISTICS

### A-Blower Operation and Adjustment<sup>1</sup>

**NOTE-** The following is a generalized procedure and does not apply to all thermostat controls.

- 1 - Blower operation is dependent on thermostat control system.
- 2 - Generally, blower operation is set at thermostat sub-base fan switch. With fan switch in **ON** position, blower operates continuously. With fan switch in **AUTO** position, blower cycles with demand or runs continuously while heating or cooling circuit cycles.
- 3 - Depending on the type of indoor thermostat, blower and entire unit will be off when the system switch is in **OFF** position.

### B-Temperature Rise (FIGURE 55)

Temperature rise for ML196DF units depends on unit input, blower speed, blower horsepower and static pressure as marked on the unit rating plate. The blower speed must be set for unit operation within the range of "TEMP. RISE °F" listed on the unit rating plate.

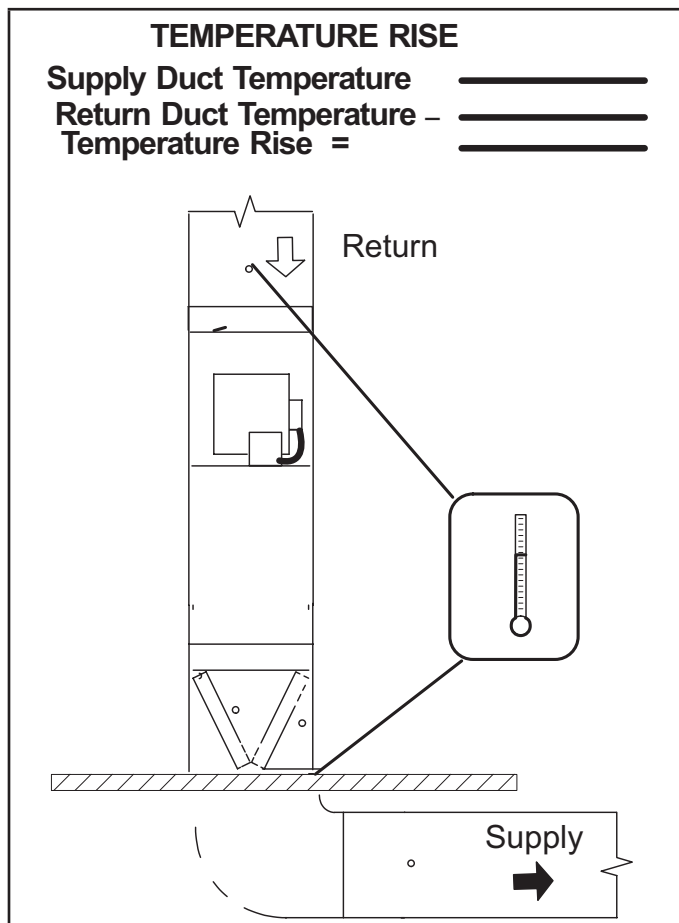

**FIGURE 55**

### C-External Static Pressure

- 1 - Tap locations shown in FIGURE 56.
- 2 - Punch a 1/4" diameter hole in supply and return air plenums. Insert manometer hose flush with inside edge of hole or insulation. Seal around the hose with permagum. Connect the zero end of the manometer to the discharge (supply) side of the system. On ducted systems, connect the other end of manometer to the return duct as above.
- 3 - With only the blower motor running and the evaporator coil dry, observe the manometer reading. Adjust blower motor speed to deliver the air desired according to the job requirements. For heating speed external static pressure drop must not be more than 0.5" W.C. For cooling speed external static pressure drop must not be more than 0.8" W.C.
- 4 - Seal the hole when the check is complete.

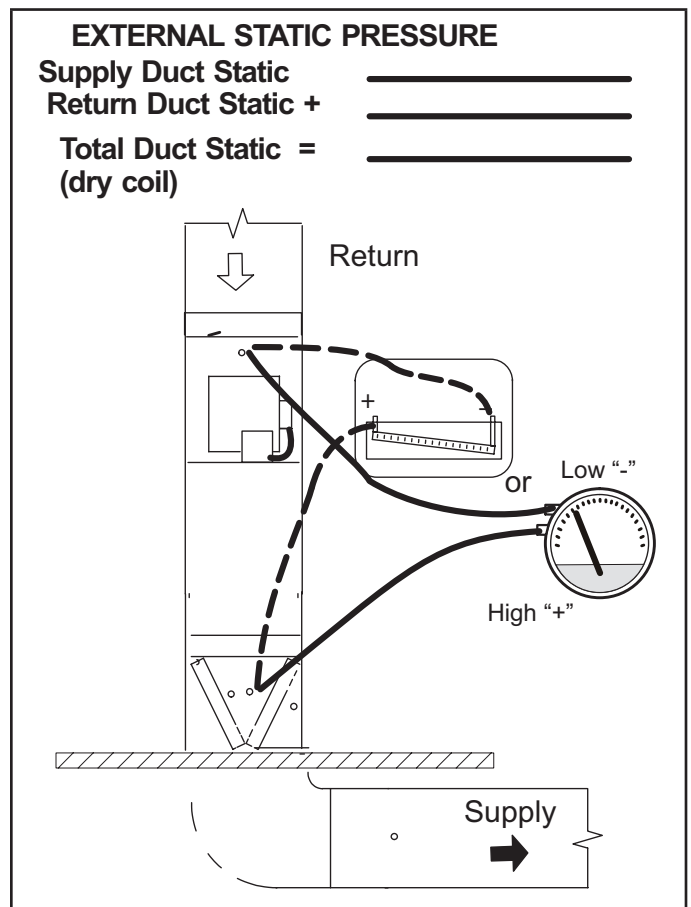

**FIGURE 56**

### D-Blower Speed Taps

Blower speed tap changes are made on the integrated control (figure 3 or 5). The heating tap is connected to the "HEAT" terminal and the cooling tap is connected to the "COOL" terminal. On all units the continuous blower tap is connected to the "FAN" terminal. Unused taps must be secured on two dummy terminals labeled "PARK". To change out existing speed tap, turn off power and switch out speed tap with tap connected to "PARK". See blower speed tap table on unit diagram for motor tap colors for each speed.

## VI-MAINTENANCE

**TABLE 22**

<b>⚠ WARNING</b>
<b>ELECTRICAL SHOCK, FIRE, OR EXPLOSION HAZARD.</b>
Failure to follow safety warnings exactly could result in dangerous operation, serious injury, death or property damage.
Improper servicing could result in dangerous operation, serious injury, death, or property damage. Before servicing, disconnect all electrical power to the furnace.

At the beginning of each heating season, system should be checked as follows by a qualified service technician:

### Blower

Check the blower wheel for debris and clean if necessary. The blower motors are prelubricated for extended bearing life. No further lubrication is needed.

<b>⚠ WARNING</b>
The blower access panel must be securely in place when the blower and burners are operating. Gas fumes, which could contain carbon monoxide, can be drawn into living space resulting in personal injury or death.

### Filters

All air filters are installed external to the unit. Filters should be inspected monthly. Clean or replace the filters when necessary to ensure proper furnace operation. TABLE 22 lists recommended filter sizes.

<b>⚠ WARNING</b>
If a highefficiency filter is being installed as part of this system to ensure better indoor air quality, the filter must be properly sized. Highefficiency filters have a higher static pressure drop than standardefficiency glass/foam filters.
If the pressure drop is too great, system capacity and performance may be reduced. The pressure drop may also cause the limit to trip more frequently during the winter and the indoor coil to freeze in the summer, resulting in an increase in the number of service calls.
Before using any filter with this system, check the specifications provided by the filter manufacturer against the data given in the appropriate Lennox Product Specifications bulletin. Additional information is provided in Service and Application Note ACC002 (August 2000).

Furnace Cabinet Width	Minimum Filter Size
17-1/2"	16 x 25 x 1 (1)
21"	

### Exhaust and air intake pipes

Check the exhaust and air intake pipes and all connections for tightness and to make sure there is no blockage.

NOTE - After any heavy snow, ice or frozen fog event the furnace vent pipes may become restricted. Always check the vent system and remove any snow or ice that may be obstructing the plastic intake or exhaust pipes.

### Electrical

<b>⚠ WARNING</b>
<b>Fire Hazard. Use of aluminum wire with this product may result in a fire, causing property damage, severe injury or death. Use copper wire only with this product.</b>

<b>⚠ WARNING</b>
<b>Failure to use properly sized wiring and circuit breaker may result in property damage. Size wiring and circuit breaker(s) per Product Specifications bulletin (EHB) and unit rating plate.</b>

- 1 - Check all wiring for loose connections.
- 2 - Check for the correct voltage at the furnace (furnace operating). Correct voltage is 120VAC + 10%
- 3 - Check amp-draw using a true RMS meter on the blower motor with blower access panel in place.

Furnace Nameplate \_\_\_\_\_ Actual \_\_\_\_\_

### Winterizing and Condensate Trap Care

- 1 - Turn off power to the furnace.
- 2 - Have a shallow pan ready to empty condensate water.
- 3 - Remove the clean out cap from the condensate trap and empty water. Inspect the trap then reinstall the clean out cap.

### Condensate Hose Screen (FIGURE 57)

Check the condensate hose screen for blockage and clean if necessary.

- 1 - Turn off power to the unit.
- 2 - Remove hose from cold end header box. Twist and pull screen to remove.
- 3 - Inspect screen and rinse with tap water if needed.
- 4 - Reinstall screen and turn on power to unit.

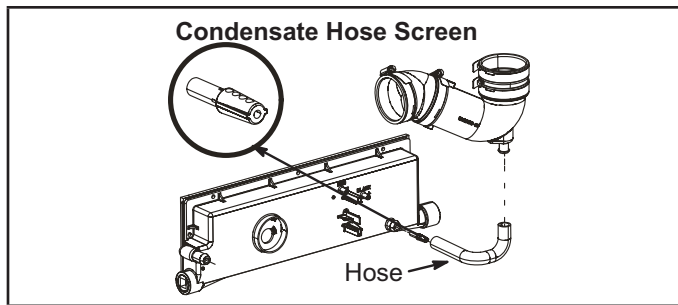

FIGURE 57

### Cleaning Heat Exchanger

If cleaning the heat exchanger becomes necessary, follow the below procedures and refer to figure 1 when disassembling unit. Use papers or protective covering in front of furnace while removing heat exchanger assembly.

- 1 - Turn off electrical and gas supplies to the furnace.
  - 2 - Remove the furnace access panels.
  - 3 - Disconnect the 2 wires from the gas valve.
  - 4 - Remove gas supply line connected to gas valve. remove as valve/manifold assembly.
  - 5 - Remove sensor wire from sensor. Disconnect 2-pin plug from the ignitor.
  - 6 - Disconnect wires from flame roll-out switches.
  - 7 - Loosen clamps at vent elbow. Disconnect condensate drain tubing from flue collar. and remove the vent elbow.
  - 8 - Remove four burner box screws at the vestibule panel and remove burner box. Set burner box assembly aside.
- NOTE** - If necessary, clean burners at this time. Follow procedures outlined in Burner Cleaning section.
- 9 - Mark and disconnect all combustion air pressure tubing from cold end header collector box.
  - 10 - Mark and remove wires from pressure switches. Remove pressure switches. Keep tubing attached to pressure switches.
  - 11 - Disconnect the plug from the combustion air inducer. Remove two screws which secure combustion air inducer to collector box. Remove combustion air inducer assembly. Remove ground wire from vest panel.
  - 12 - Remove electrical junction box from the side of the furnace.
  - 13 - Mark and disconnect any remaining wiring to heating compartment components. Disengage strain relief bushing and pull wiring and bushing through the hole in the blower deck.
  - 14 - Remove the primary limit from the vestibule panel.
  - 15 - Remove two screws from the front cabinet flange at the blower deck. Spread cabinet sides slightly to allow clearance for removal of heat exchanger.

- 16 - Remove screws along vestibule sides and bottom which secure vestibule panel and heat exchanger assembly to cabinet. Remove two screws from blower rail which secure bottom heat exchanger flange. Remove heat exchanger from furnace cabinet.
- 17 - Back wash heat exchanger with soapy water solution or steam. If steam is used it must be below 275°F (135°C) .
- 18 - Thoroughly rinse and drain the heat exchanger. Soap solutions can be corrosive. Take care to rinse entire assembly.
- 19 - Reinstall heat exchanger into cabinet making sure that the clamshells of the heat exchanger assembly are resting on the support located at the rear of the cabinet. Remove the indoor blower to view this area through the blower opening.
- 20 - Re-secure the supporting screws along the vestibule sides and bottom to the cabinet. Reinstall blower and mounting screws.
- 21 - Reinstall cabinet screws on front flange at blower deck.
- 22 - Reinstall the primary limit on the vestibule panel.
- 23 - Route heating component wiring through hole in blower deck and reinsert strain relief bushing.
- 24 - Reinstall electrical junction box.
- 25 - Reinstall the combustion air inducer. Reconnect the combustion air inducer to the wire harness.
- 26 - Reinstall pressure switches and reconnect pressure switch wiring.
- 27 - Carefully connect combustion air pressure switch hosing from pressure switches to proper stubs on cold end header collector box.
- 28 - Reinstall condensate trap.
- 29 - Reconnect exhaust piping and exhaust drain tubing.
- 30 - Reinstall burner box assembly in vestibule area.
- 31 - Reconnect flame roll-out switch wires.
- 32 - Reconnect sensor wire and reconnect 2-pin plug from ignitor.
- 33 - Secure burner box assembly to vestibule panel using four existing screws. Make sure burners line up in center of burner ports.
- 34 - Reinstall gas valve manifold assembly. Reconnect gas supply line to gas valve.
- 35 - Reconnect 2 wires to gas valve.
- 36 - Replace the blower compartment access panel.
- 37 - Refer to instruction on verifying gas and electrical connections when re-establishing supplies.
- 38 - Follow lighting instructions to light and operate furnace for 5 minutes to ensure that heat exchanger is clean and dry and that furnace is operating properly.
- 39 - Replace heating compartment access panel.

## **Cleaning the Burner Assembly**

- 1 - Turn off electrical and gas power supplies to furnace. Remove upper and lower furnace access panels.
- 2 - Disconnect the 2-pin plug from the gas valve.
- 3 - Remove the burner box cover.
- 4 - Disconnect the gas supply line from the gas valve. Remove gas valve/manifold assembly.
- 5 - Mark and disconnect sensor wire from the sensor. Disconnect 2-pin plug from the ignitor at the burner box.
- 6 - Remove four screws which secure burner box assembly to vest panel. Remove burner box from the unit.
- 7 - Use the soft brush attachment on a vacuum cleaner to gently clean the face of the burners. Visually inspect the inside of the burners and crossovers for any blockage caused by foreign matter. Remove any blockage.
- 8 - Reconnect the sensor wire and reconnect the 2-pin plug to the ignitor wiring harness.
- 9 - Reinstall the burner box assembly using the existing four screws. Make sure that the burners line up in the center of the burner ports.
- 10 - Reinstall the gas valve manifold assembly. Reconnect the gas supply line to the gas valve. Reinstall the burner box cover.
- 11 - Reconnect 2-pin plug to gas valve.
- 12 - Replace the blower compartment access panel.
- 13 - Refer to instruction on verifying gas and electrical connections when re-establishing supplies.
- 14 - Follow lighting instructions to light and operate furnace for 5 minutes to ensure that heat exchanger is clean and dry and that furnace is operating properly.
- 15 - Replace heating compartment access panel.



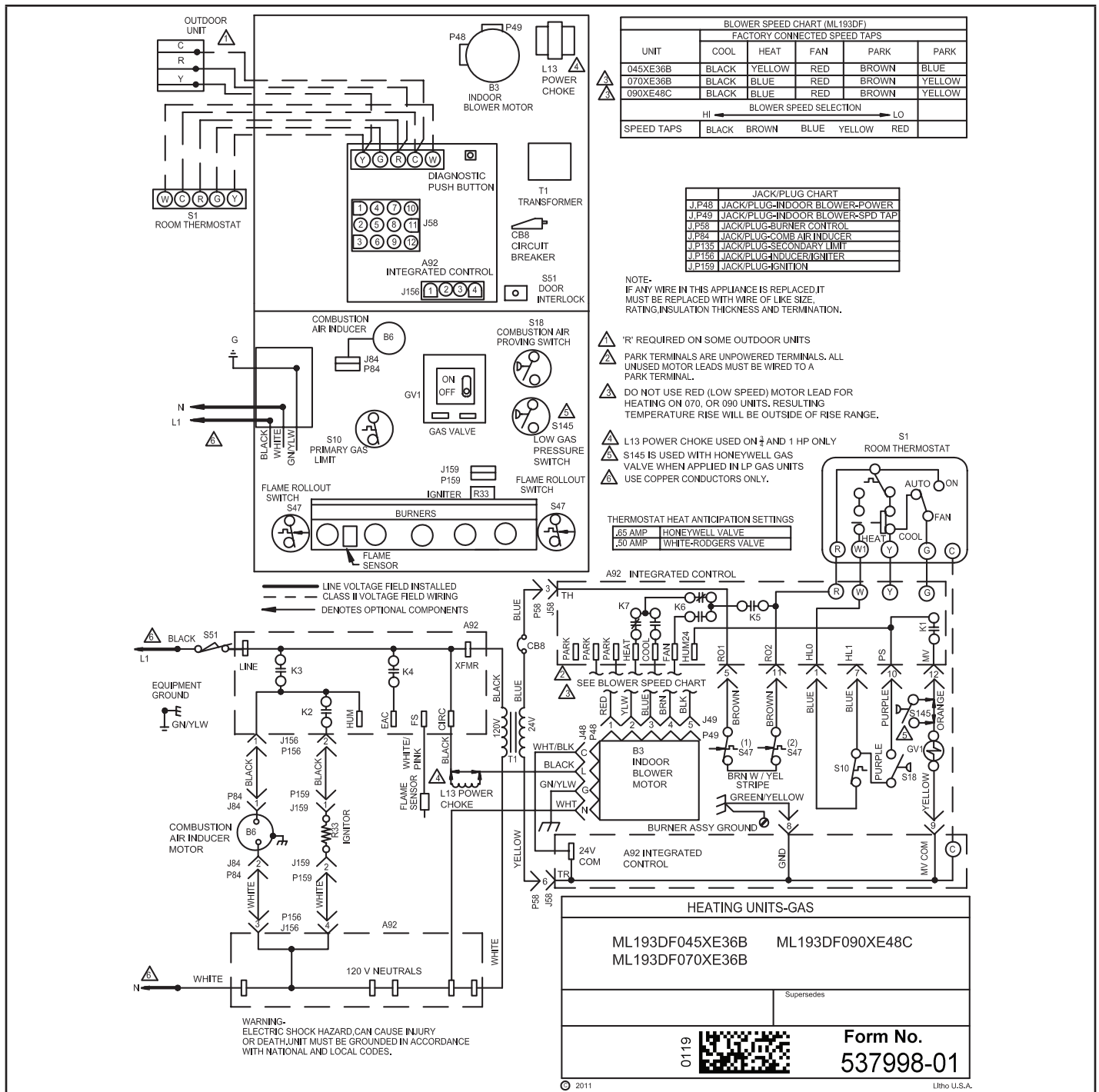

- 1 - When there is a call for heat, W1 of the thermostat energizes W of the furnace control with 24VAC.
- 2 - S10 primary limit switch and S47 rollout switch are closed. Call for heat can continue.
- 3 - The integrated control (A92) energizes combustion air inducer B6. Combustion air inducer runs until S18 combustion air prove switch closes (switch must close within 2-1/2 minutes or control goes into 5 minute Watchguard Pressure Switch delay). Once S18 closes, a 15-second pre-purge follows.
- 4 - The integrated control (A92) energizes ignitor. A 20-second warm-up period begins.

- 5 - Gas valve opens for a 4-second trial for ignition
- 6 - Flame is sensed, gas valve remains open for the heat call.
- 7 - After 30-second delay, the integrated control (A92) energizes indoor blower B3.
- 8 - When heat demand is satisfied, W1 of the indoor thermostat de-energizes W of the integrated control which de-energizes the gas valve. Combustion air inducer B6 continues a 5-second post-purge period, and indoor blower B3 completes a selected OFF time delay.

### HEATING SEQUENCE OF OPERATION

#### NORMAL HEATING MODE

#### ABNORMAL HEATING MODE

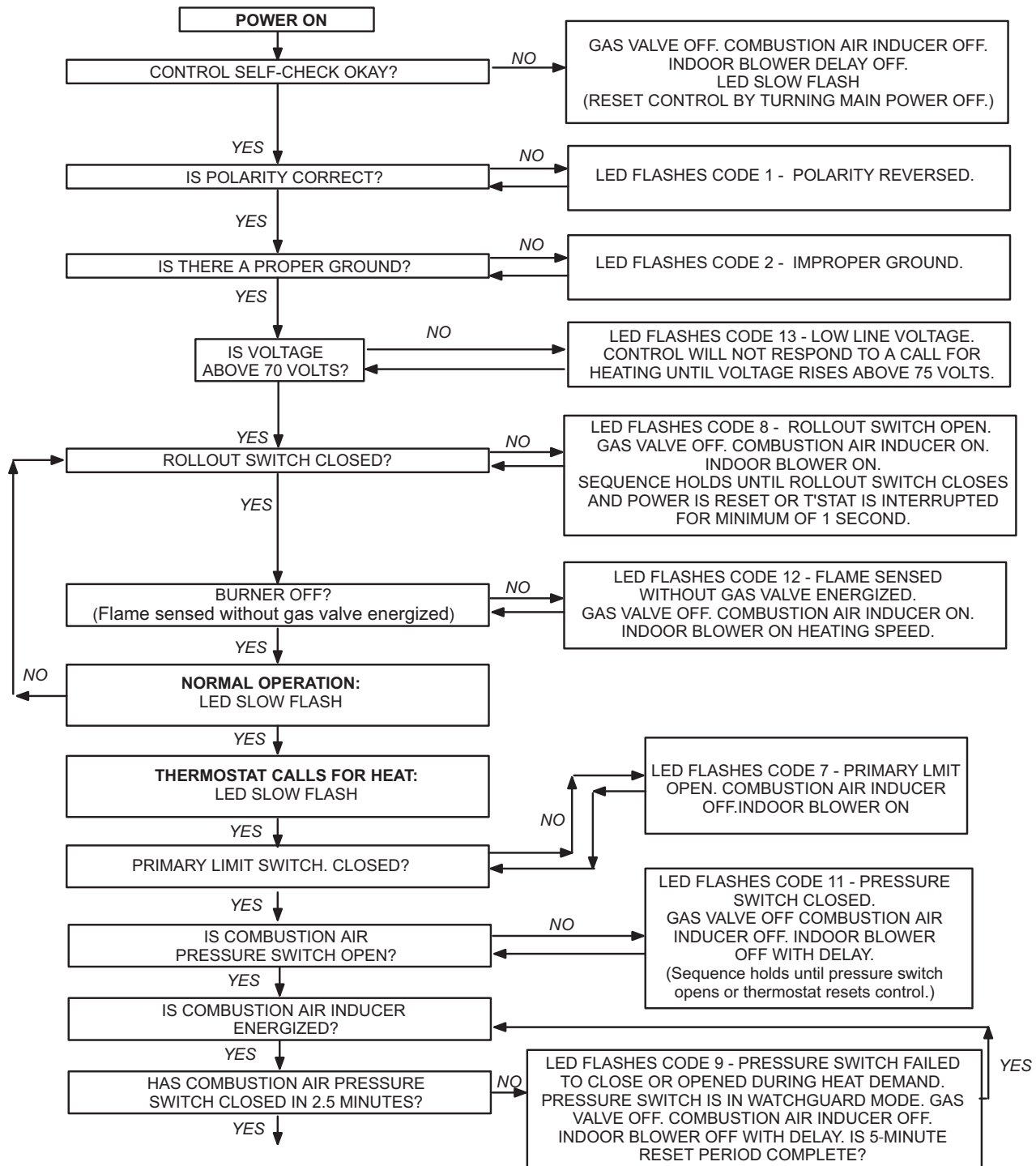

HEATING SEQUENCE CONTINUED

NORMAL HEATING MODE

ABNORMAL HEATING MODE

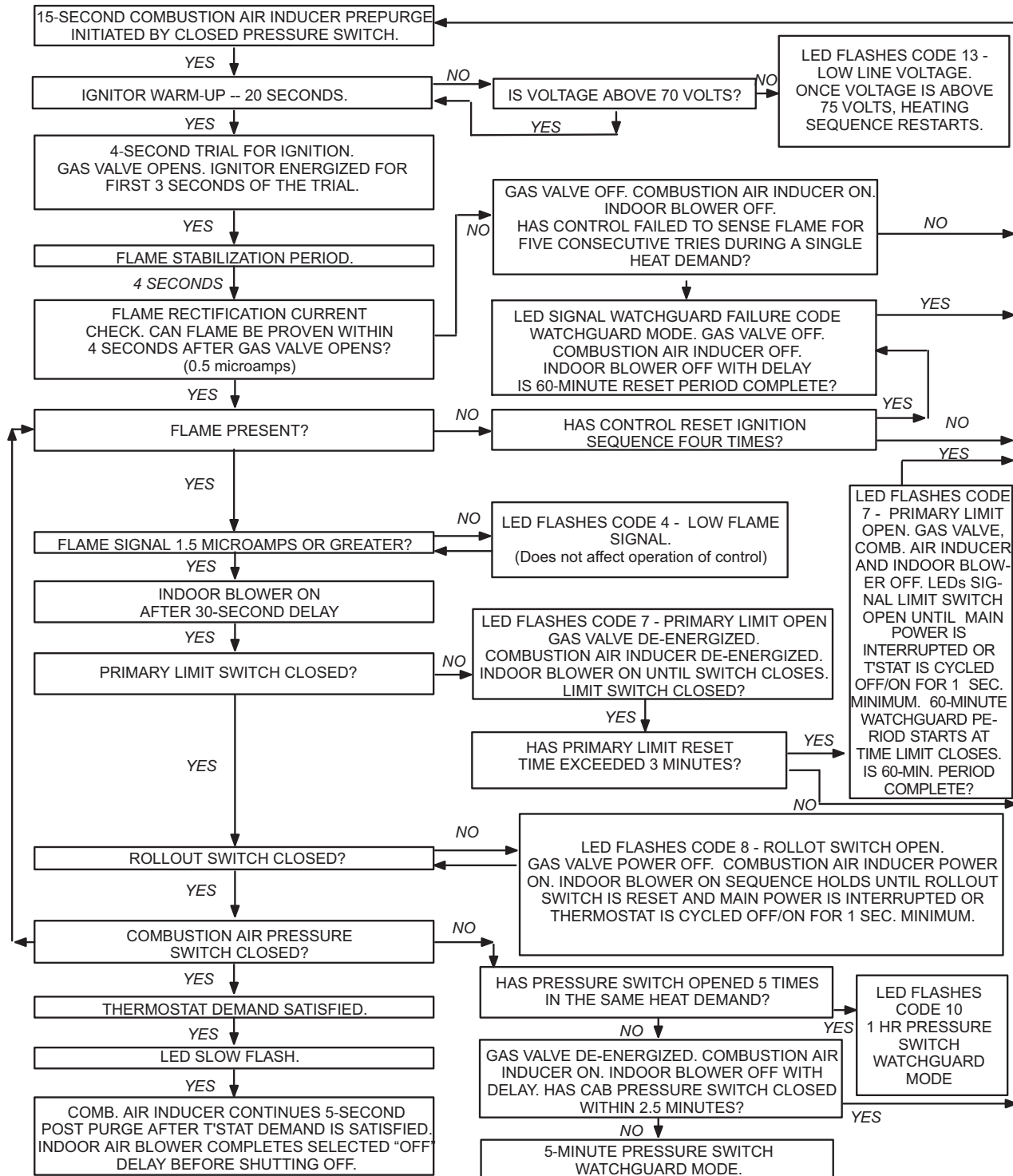

### COOLING SEQUENCE OF OPERATION

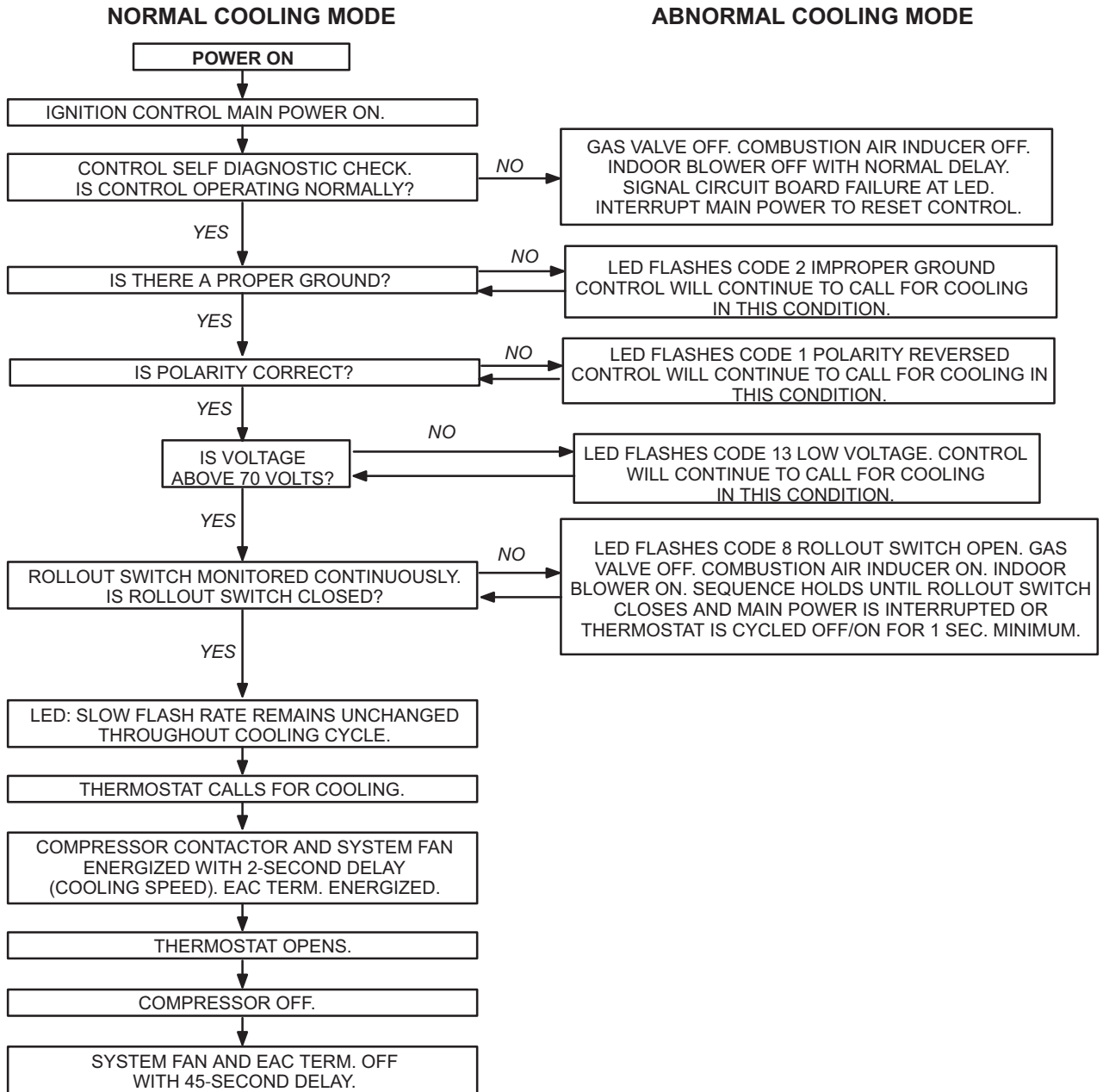

### CONTINUOUS FAN SEQUENCE OF OPERATION

