



538210-01

01

02

03

04

05

06

07

08

09

10

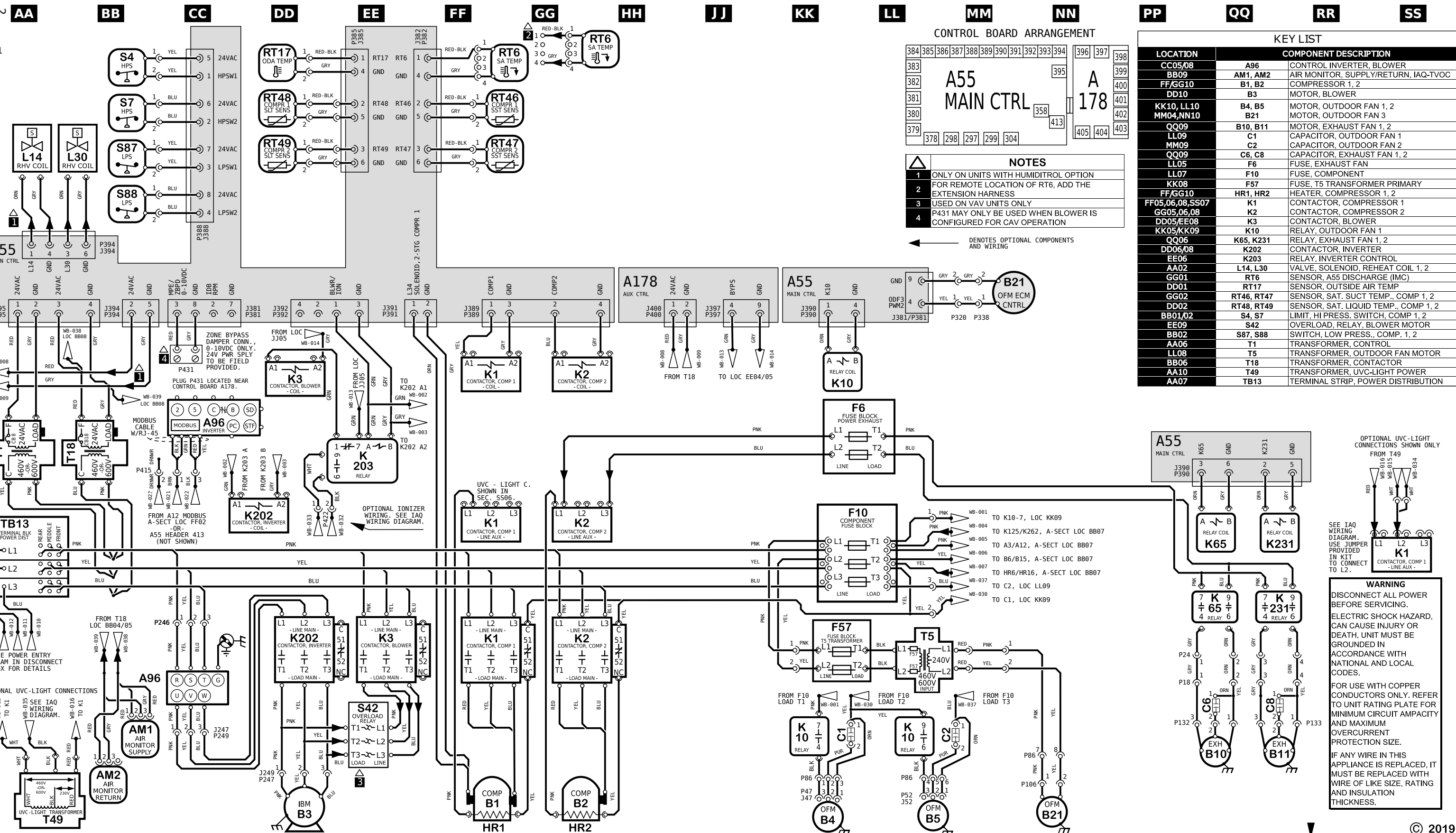

CONTROL BOARD ARRANGEMENT

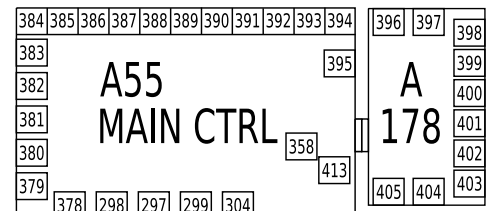

- NOTES**
- 1 ONLY ON UNITS WITH HUMIDITROL OPTION
 - 2 FOR REMOTE LOCATION OF RT6, ADD THE EXTENSION HARNESS
 - 3 USED ON VAV UNITS ONLY
 - 4 P431 MAY ONLY BE USED WHEN BLOWER IS CONFIGURED FOR CAV OPERATION

← DENOTES OPTIONAL COMPONENTS AND WIRING

KEY LIST

LOCATION	COMPONENT DESCRIPTION
CC05/08	A96 CONTROL INVERTER, BLOWER
BB09	AM1, AM2 AIR MONITOR, SUPPLY/RETURN, IAQ-TVOC
FF/GG10	B1, B2 COMPRESSOR 1, 2
DD10	B3 MOTOR, BLOWER
KK10, LL10	B4, B5 MOTOR, OUTDOOR FAN 1, 2
MM04, NN10	B21 MOTOR, OUTDOOR FAN 3
QQ09	B10, B11 MOTOR, EXHAUST FAN 1, 2
LL09	C1 CAPACITOR, OUTDOOR FAN 1
MM09	C2 CAPACITOR, OUTDOOR FAN 2
QQ09	C6, C8 CAPACITOR, EXHAUST FAN 1, 2
LL05	F6 FUSE, EXHAUST FAN
LL07	F10 FUSE, COMPONENT
KK08	F57 FUSE, T5 TRANSFORMER PRIMARY
FF/GG10	HR1, HR2 HEATER, COMPRESSOR 1, 2
FF05,06,08,SS07	K1 CONTACTOR, COMPRESSOR 1
GG05,06,08	K2 CONTACTOR, COMPRESSOR 2
DD05/EE08	K3 CONTACTOR, BLOWER
KK05/KK09	K10 RELAY, OUTDOOR FAN 1
QQ06	K65, K231 RELAY, EXHAUST FAN 1, 2
DD06/08	K202 CONTACTOR, INVERTER
EE06	K203 RELAY, INVERTER CONTROL
AA02	L14, L30 VALVE, SOLENOID, REHEAT COIL 1, 2
GG01	RT6 SENSOR, A55 DISCHARGE (IMC)
DD01	RT17 SENSOR, OUTSIDE AIR TEMP
GG02	RT46, RT47 SENSOR, SAT. SUCT TEMP., COMP 1, 2
DD02	RT48, RT49 SENSOR, SAT. LIQUID TEMP., COMP 1, 2
BB01/02	S4, S7 LIMIT, HI PRESS. SWITCH, COMP 1, 2
EE09	S42 OVERLOAD, RELAY, BLOWER MOTOR
BB02	S87, S88 SWITCH, LOW PRESS., COMP. 1, 2
AA05	T1 TRANSFORMER, CONTROL
LL08	T5 TRANSFORMER, OUTDOOR FAN MOTOR
BB06	T18 TRANSFORMER, CONTACTOR
AA10	T49 TRANSFORMER, UVC-LIGHT POWER
AA07	TB13 TERMINAL STRIP, POWER DISTRIBUTION

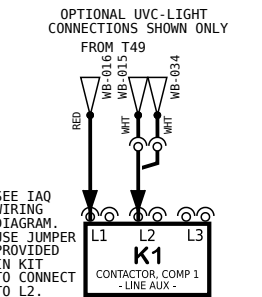

WARNING
DISCONNECT ALL POWER BEFORE SERVICING.
ELECTRIC SHOCK HAZARD, CAN CAUSE INJURY OR DEATH. UNIT MUST BE GROUNDED IN ACCORDANCE WITH NATIONAL AND LOCAL CODES.
FOR USE WITH COPPER CONDUCTORS ONLY. REFER TO UNIT RATING PLATE FOR MINIMUM CIRCUIT AMPACITY AND MAXIMUM OVERCURRENT PROTECTION SIZE.
IF ANY WIRE IN THIS APPLIANCE IS REPLACED, IT MUST BE REPLACED WITH WIRE OF LIKE SIZE, RATING AND INSULATION THICKNESS.

Model: LGT, LCT 156H - G, J-VOLT
COOLING - MSAV WITH BYPASS - 2 COMPRESSORS 3 CONDENSER FANS

Voltage: 460V/3~60Hz (G), 575V/3~60Hz (J)
Supersedes: N/A Form No: 538210-01 Rev: 2

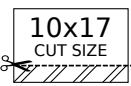
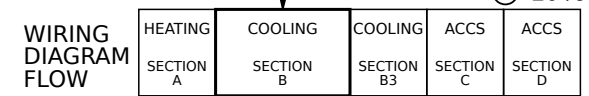

REV	EC NO.	DATE	BY	APVD	REVISION NOTE
---	CN-010356	06-14-2022	MXR6	JAL21	ORIGINATED AT PD&R CARROLLTON, TX
001	CN-010356E	07-26-2022	MXR6	JAL21	A) REVERSED HIGH VOLTAGE WIRING ON T18 TRANSFORMER.
002	CN-010356L	09-12-2022	MXR6	JAL21	A) ADDED K10-6/-9 TO CONDENSER FAN SECTION. P86-7/-8 WAS P87-1/-2.

© 2019

538210-01
01

02

03

04

05

06

07

08

09

10

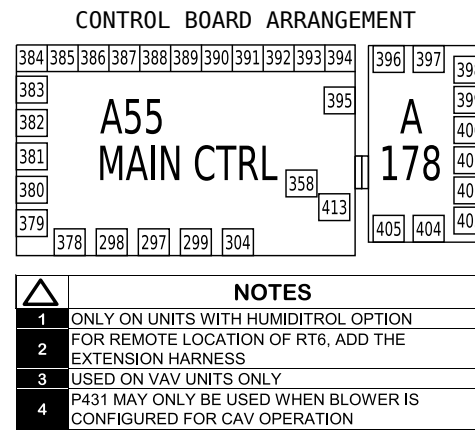
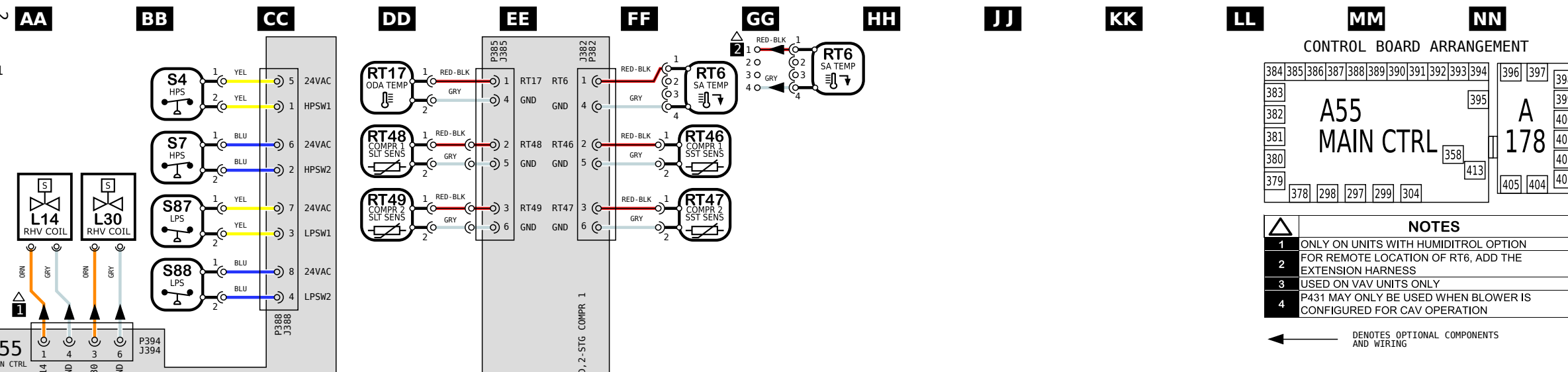

LOCATION	COMPONENT DESCRIPTION
CC05/08	A96 CONTROL INVERTER, BLOWER
BB09	AM1, AM2 AIR MONITOR, SUPPLY/RETURN, IAQ-TVOC
FF/GG10	B1, B2 COMPRESSOR 1, 2
DD10	B3 MOTOR, BLOWER
KK10, LL10	B4, B5 MOTOR, OUTDOOR FAN 1, 2
MM04, NN10	B21 MOTOR, OUTDOOR FAN 3
QQ09	B10, B11 MOTOR, EXHAUST FAN 1, 2
LL09	C1 CAPACITOR, OUTDOOR FAN 1
MM09	C2 CAPACITOR, OUTDOOR FAN 2
QQ09	C6, C8 CAPACITOR, EXHAUST FAN 1, 2
LL05	F6 FUSE, EXHAUST FAN
LL07	F10 FUSE, COMPONENT
KK08	F57 FUSE, T5 TRANSFORMER PRIMARY
FF/GG10	HR1, HR2 HEATER, COMPRESSOR 1, 2
FF05,06,08,SS07	K1 CONTACTOR, COMPRESSOR 1
GG05,06,08	K2 CONTACTOR, COMPRESSOR 2
DD05/EE08	K3 CONTACTOR, BLOWER
KK05/KK09	K10 RELAY, OUTDOOR FAN 1
QQ06	K65, K231 RELAY, EXHAUST FAN 1, 2
DD06/08	K202 CONTACTOR, INVERTER
EE06	K203 RELAY, INVERTER CONTROL
AA02	L14, L30 VALVE, SOLENOID, REHEAT COIL 1, 2
GG01	RT6 SENSOR, A55 DISCHARGE (IMC)
DD01	RT17 SENSOR, OUTSIDE AIR TEMP
GG02	RT46, RT47 SENSOR, SAT. SUCT TEMP., COMP 1, 2
DD02	RT48, RT49 SENSOR, SAT. LIQUID TEMP., COMP 1, 2
BB01/02	S4, S7 LIMIT, HI PRESS. SWITCH, COMP 1, 2
EE09	S42 OVERLOAD, RELAY, BLOWER MOTOR
BB02	S87, S88 SWITCH, LOW PRESS., COMP. 1, 2
AA05	T1 TRANSFORMER, CONTROL
LL08	T5 TRANSFORMER, OUTDOOR FAN MOTOR
BB06	T18 TRANSFORMER, CONTACTOR
AA10	T49 TRANSFORMER, UVC-LIGHT POWER
AA07	TB13 TERMINAL STRIP, POWER DISTRIBUTION

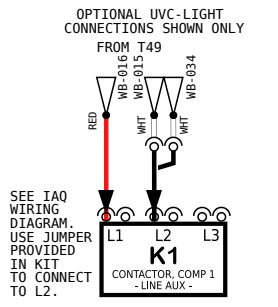
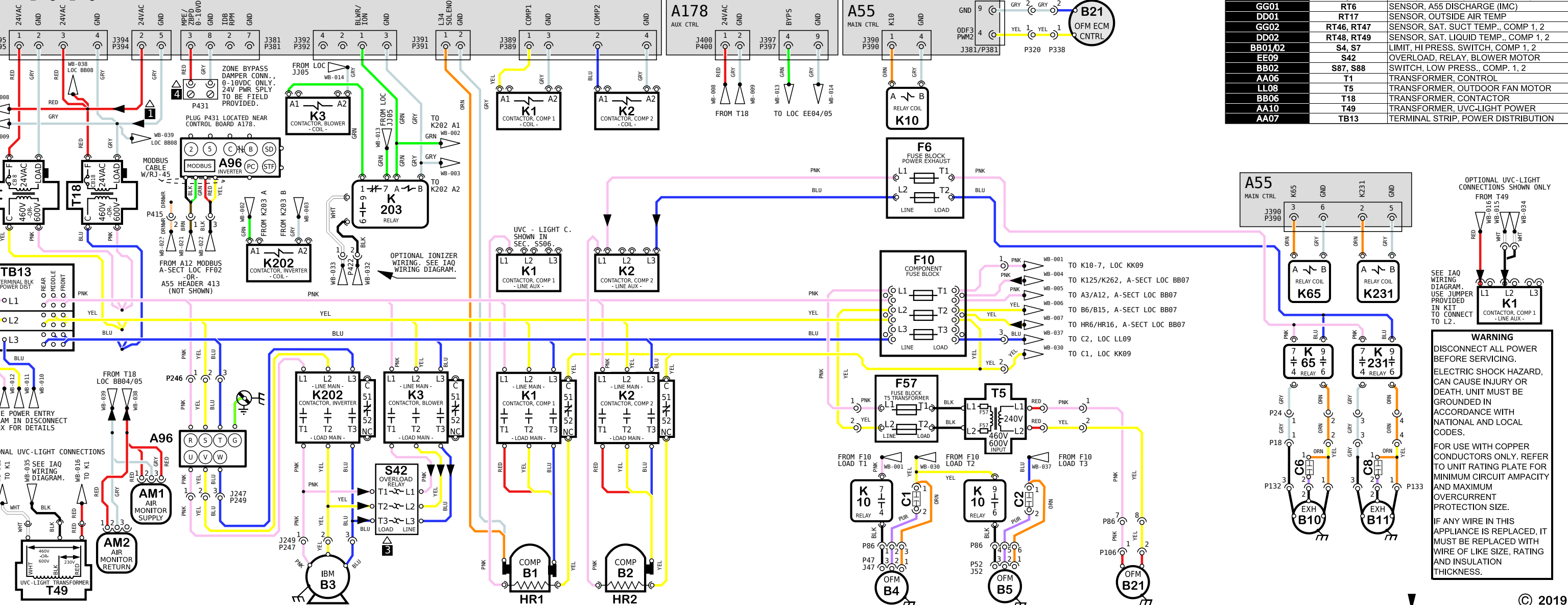

WARNING
DISCONNECT ALL POWER BEFORE SERVICING.
ELECTRIC SHOCK HAZARD, CAN CAUSE INJURY OR DEATH. UNIT MUST BE GROUNDED IN ACCORDANCE WITH NATIONAL AND LOCAL CODES.
FOR USE WITH COPPER CONDUCTORS ONLY. REFER TO UNIT RATING PLATE FOR MINIMUM CIRCUIT AMPACITY AND MAXIMUM OVERCURRENT PROTECTION SIZE.
IF ANY WIRE IN THIS APPLIANCE IS REPLACED, IT MUST BE REPLACED WITH WIRE OF LIKE SIZE, RATING AND INSULATION THICKNESS.

Model: LGT, LCT 156H - G, J-VOLT
COOLING - MSAV WITH BYPASS - 2 COMPRESSORS 3 CONDENSER FANS

Voltage: 460V/3~60Hz (G), 575V/3~60Hz (J)
Supersedes: N/A Form No: 538210-01 Rev: 2

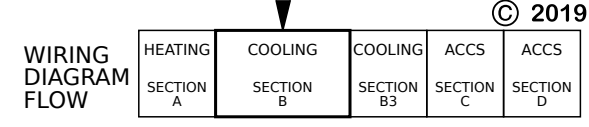

10x17 CUT SIZE

REV	EC NO.	DATE	BY	APVD	REVISION NOTE
---	CN-010356	06-14-2022	MXR6	JAL21	ORIGINATED AT PD&R CARROLLTON, TX
001	CN-010356E	07-26-2022	MXR6	JAL21	A) REVERSED HIGH VOLTAGE WIRING ON T18 TRANSFORMER.
002	CN-010356L	09-12-2022	MXR6	JAL21	A) ADDED K10-6/-9 TO CONDENSER FAN SECTION. P86-7/-8 WAS P87-1/-2.