



538228-01

01

02

03

04

05

06

07

08

09

10

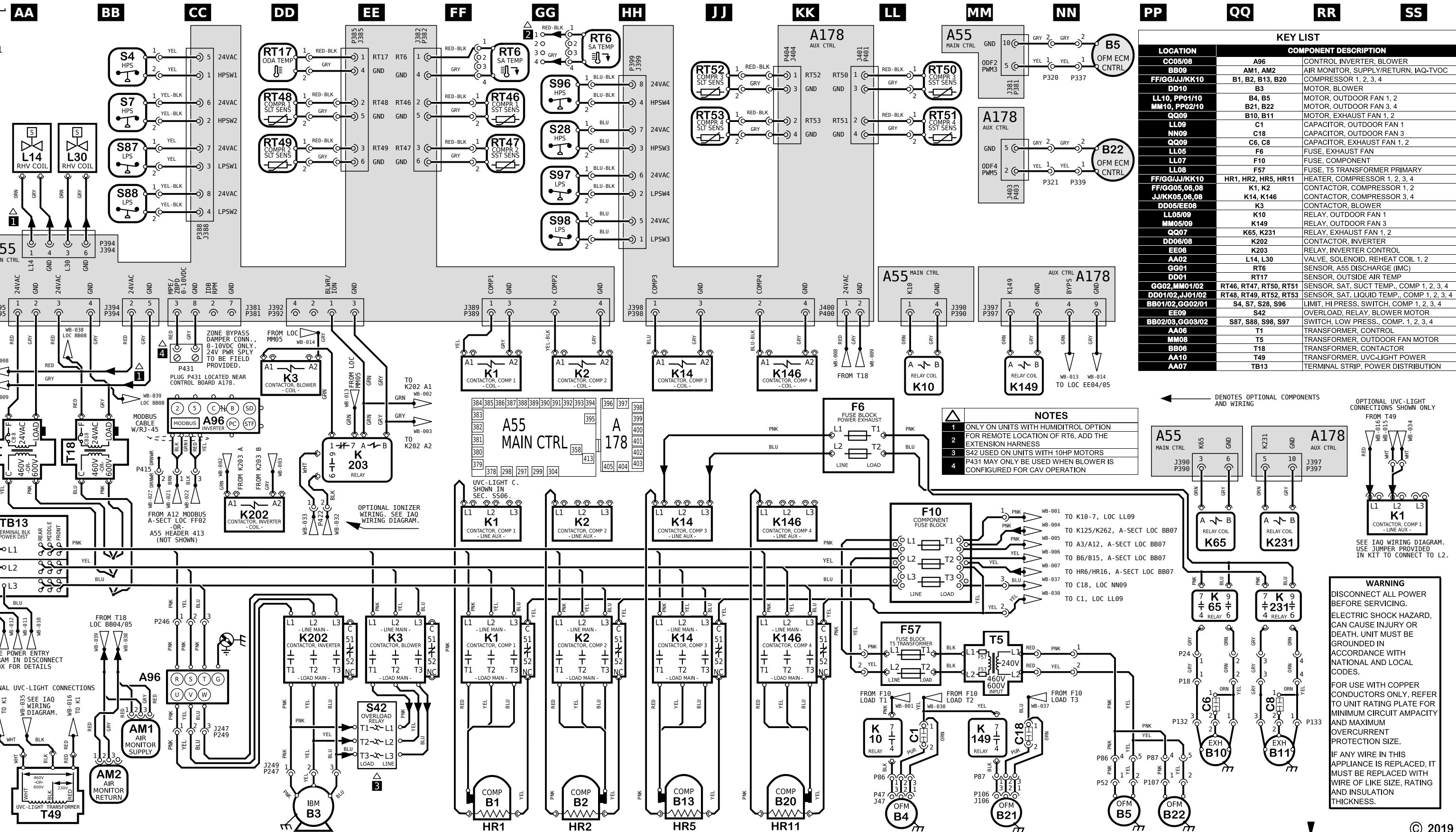

| KEY LIST | | |
|------------------|------------------------|--|
| LOCATION | COMPONENT DESCRIPTION | |
| CC05/08 | A96 | CONTROL INVERTER, BLOWER |
| BB09 | AM1, AM2 | AIR MONITOR, SUPPLY/RETURN, IAQ-TVOC |
| FF/GG/JJ/KK10 | B1, B2, B13, B20 | COMPRESSOR 1, 2, 3, 4 |
| DD10 | B3 | MOTOR, BLOWER |
| LL10, PP01/10 | B4, B5 | MOTOR, OUTDOOR FAN 1, 2 |
| MM10, PP02/10 | B21, B22 | MOTOR, OUTDOOR FAN 3, 4 |
| QQ09 | B10, B11 | MOTOR, EXHAUST FAN 1, 2 |
| LL09 | C1 | CAPACITOR, OUTDOOR FAN 1 |
| NN09 | C18 | CAPACITOR, OUTDOOR FAN 3 |
| QQ09 | C6, C8 | CAPACITOR, EXHAUST FAN 1, 2 |
| LL05 | F6 | FUSE, EXHAUST FAN |
| LL07 | F10 | FUSE, COMPONENT |
| LL08 | F57 | FUSE, T5 TRANSFORMER PRIMARY |
| FF/GG/JJ/KK10 | HR1, HR2, HR5, HR11 | HEATER, COMPRESSOR 1, 2, 3, 4 |
| FF/GG05,06,08 | K1, K2 | CONTACTOR, COMPRESSOR 1, 2 |
| JJ/KK05,06,08 | K14, K146 | CONTACTOR, COMPRESSOR 3, 4 |
| DD05/EE06 | K3 | CONTACTOR, BLOWER |
| LL05/09 | K10 | RELAY, OUTDOOR FAN 1 |
| MM05/09 | K149 | RELAY, OUTDOOR FAN 3 |
| QQ07 | K65, K231 | RELAY, EXHAUST FAN 1, 2 |
| DD08/08 | K202 | CONTACTOR, INVERTER |
| EE06 | K203 | RELAY, INVERTER CONTROL |
| AA02 | L14, L30 | VALVE, SOLENOID, REHEAT COIL 1, 2 |
| GG01 | RT6 | SENSOR, A55 DISCHARGE (IMC) |
| DD01 | RT17 | SENSOR, OUTSIDE AIR TEMP |
| GG02, MM01/02 | RT46, RT47, RT50, RT51 | SENSOR, SAT. SUCT TEMP., COMP 1, 2, 3, 4 |
| DD01/02, JJ01/02 | RT48, RT49, RT52, RT53 | SENSOR, SAT. LIQUID TEMP., COMP 1, 2, 3, 4 |
| BB01/02, GG02/01 | S4, S7, S28, S96 | LIMIT, HI PRESS. SWITCH, COMP 1, 2, 3, 4 |
| EE09 | S42 | OVERLOAD, RELAY, BLOWER MOTOR |
| BB02/03, GG03/02 | S87, S88, S98, S97 | SWITCH, LOW PRESS., COMP. 1, 2, 3, 4 |
| AA06 | T1 | TRANSFORMER, CONTROL |
| MM08 | T5 | TRANSFORMER, OUTDOOR FAN MOTOR |
| BB06 | T18 | TRANSFORMER, CONTACTOR |
| AA10 | T49 | TRANSFORMER, UVC-LIGHT POWER |
| AA07 | TB13 | TERMINAL STRIP, POWER DISTRIBUTION |

NOTES

- 1 ONLY ON UNITS WITH HUMIDITROL OPTION FOR REMOTE LOCATION OF RT6, ADD THE EXTENSION HARNESS
- 2 S42 USED ON UNITS WITH 10HP MOTORS
- 3 P431 MAY ONLY BE USED WHEN BLOWER IS CONFIGURED FOR CAV OPERATION
- 4

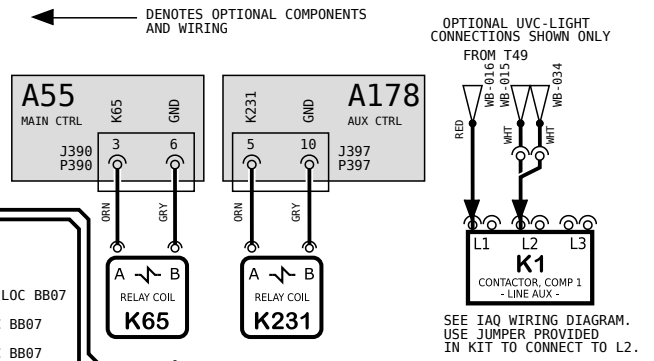

WARNING

DISCONNECT ALL POWER BEFORE SERVICING. ELECTRIC SHOCK HAZARD, CAN CAUSE INJURY OR DEATH. UNIT MUST BE GROUNDED IN ACCORDANCE WITH NATIONAL AND LOCAL CODES.

FOR USE WITH COPPER CONDUCTORS ONLY. REFER TO UNIT RATING PLATE FOR MINIMUM CIRCUIT AMPACITY AND MAXIMUM OVERCURRENT PROTECTION SIZE.

IF ANY WIRE IN THIS APPLIANCE IS REPLACED, IT MUST BE REPLACED WITH WIRE OF LIKE SIZE, RATING AND INSULATION THICKNESS.

Model: LGT, LCT 210H - G, J-VOLT
COOLING - MSAV WITH BYPASS - 4 COMPRESSORS 4 CONDENSER FANS

Voltage: 460V/3~/60Hz (G), 575V/3~/60Hz (J)
Supersedes: N/A Form No: 538228-01 Rev: 1

© 2019

| | | | | |
|-------------------|-------------------|--------------------|----------------|----------------|
| HEATING SECTION A | COOLING SECTION B | COOLING SECTION B3 | ACCS SECTION C | ACCS SECTION D |
|-------------------|-------------------|--------------------|----------------|----------------|

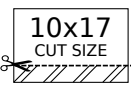

| REV | EC NO. | DATE | BY | APVD | REVISION NOTE |
|-----|------------|------------|------|-------|---|
| --- | CN-010356 | 06-20-2022 | MXR6 | JAL21 | ORIGINATED AT PD&R CARROLLTON, TX |
| 001 | CN-010356E | 07-26-2022 | MXR6 | JAL21 | A) REVERSED HIGH VOLTAGE WIRING ON T18 TRANSFORMER. |



538228-01

01

02

03

04

05

06

07

08

09

10

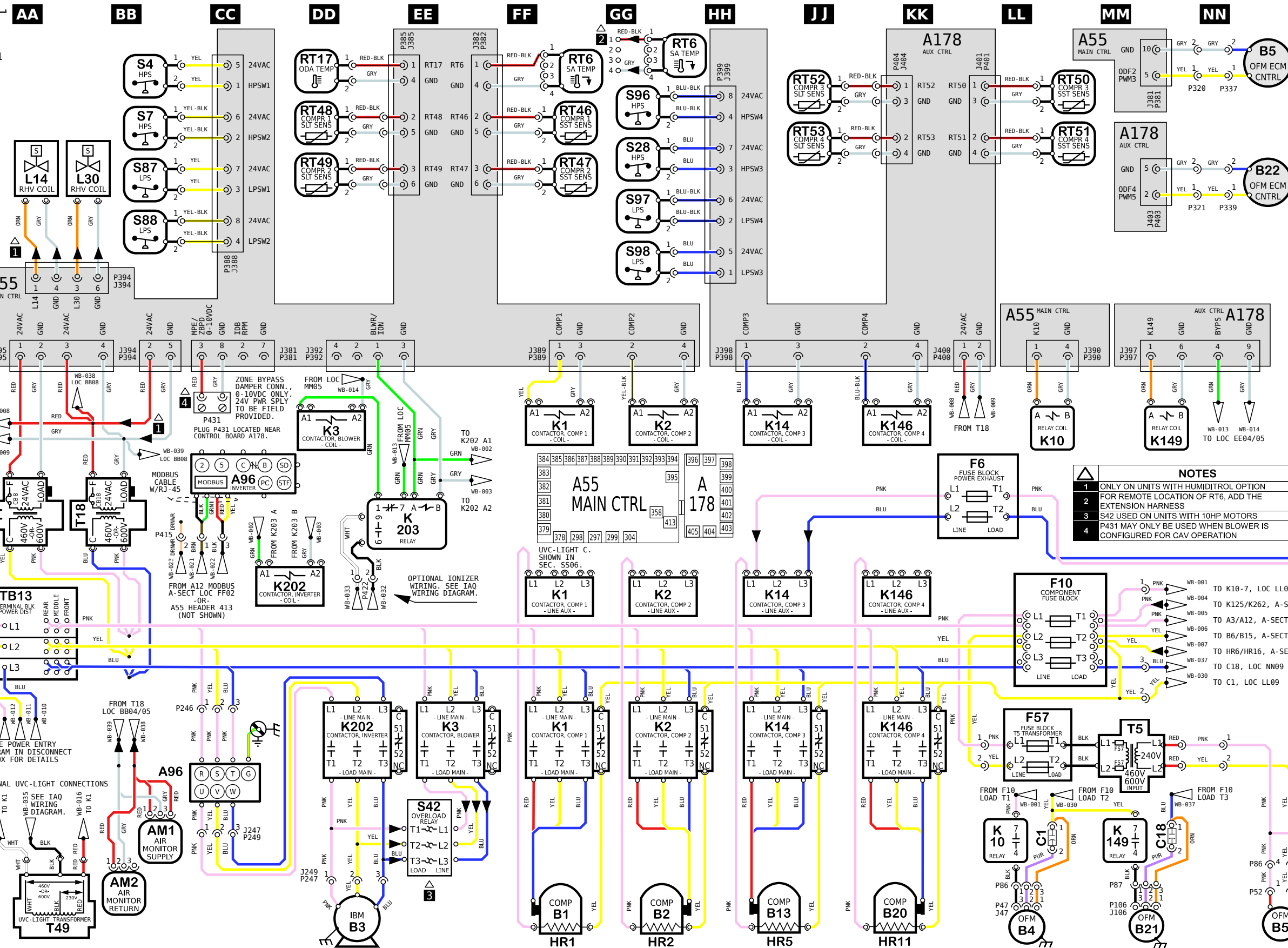

| LOCATION | COMPONENT DESCRIPTION | |
|------------------|------------------------|--|
| CC05/08 | A96 | CONTROL INVERTER, BLOWER |
| BB09 | AM1, AM2 | AIR MONITOR, SUPPLY/RETURN, IAQ-TVOC |
| FF/GG/JJ/KK10 | B1, B2, B13, B20 | COMPRESSOR 1, 2, 3, 4 |
| DD10 | B3 | MOTOR, BLOWER |
| LL10, PP01/10 | B4, B5 | MOTOR, OUTDOOR FAN 1, 2 |
| MM10, PP02/10 | B21, B22 | MOTOR, OUTDOOR FAN 3, 4 |
| QQ09 | B10, B11 | MOTOR, EXHAUST FAN 1, 2 |
| LL09 | C1 | CAPACITOR, OUTDOOR FAN 1 |
| NN09 | C18 | CAPACITOR, OUTDOOR FAN 3 |
| QQ09 | C6, C8 | CAPACITOR, EXHAUST FAN 1, 2 |
| LL05 | F6 | FUSE, EXHAUST FAN |
| LL07 | F10 | FUSE, COMPONENT |
| LL08 | F57 | FUSE, T5 TRANSFORMER PRIMARY |
| FF/GG/JJ/KK10 | HR1, HR2, HR5, HR11 | HEATER, COMPRESSOR 1, 2, 3, 4 |
| FF/GG05,06,08 | K1, K2 | CONTACTOR, COMPRESSOR 1, 2 |
| JJ/KK05,06,08 | K14, K146 | CONTACTOR, COMPRESSOR 3, 4 |
| DD05/EE06 | K3 | CONTACTOR, BLOWER |
| LL05/09 | K10 | RELAY, OUTDOOR FAN 1 |
| MM05/09 | K149 | RELAY, OUTDOOR FAN 3 |
| QQ07 | K65, K231 | RELAY, EXHAUST FAN 1, 2 |
| DD08/08 | K202 | CONTACTOR, INVERTER |
| EE06 | K203 | RELAY, INVERTER CONTROL |
| AA02 | L14, L30 | VALVE, SOLENOID, REHEAT COIL 1, 2 |
| GG01 | RT6 | SENSOR, A55 DISCHARGE (IMC) |
| DD01 | RT17 | SENSOR, OUTSIDE AIR TEMP |
| GG02, MM01/02 | RT46, RT47, RT50, RT51 | SENSOR, SAT. SUCT TEMP., COMP 1, 2, 3, 4 |
| DD01/02, JJ01/02 | RT48, RT49, RT52, RT53 | SENSOR, SAT. LIQUID TEMP., COMP 1, 2, 3, 4 |
| BB01/02, GG02/01 | S4, S7, S28, S96 | LIMIT, HI PRESS. SWITCH, COMP 1, 2, 3, 4 |
| EE09 | S42 | OVERLOAD, RELAY, BLOWER MOTOR |
| BB02/03, GG03/02 | S87, S88, S98, S97 | SWITCH, LOW PRESS., COMP. 1, 2, 3, 4 |
| AA06 | T1 | TRANSFORMER, CONTROL |
| MM08 | T5 | TRANSFORMER, OUTDOOR FAN MOTOR |
| BB06 | T18 | TRANSFORMER, CONTACTOR |
| AA10 | T49 | TRANSFORMER, UVC-LIGHT POWER |
| AA07 | TB13 | TERMINAL STRIP, POWER DISTRIBUTION |

- NOTES**
- 1 ONLY ON UNITS WITH HUMIDITROL OPTION
 - 2 FOR REMOTE LOCATION OF RT6, ADD THE EXTENSION HARNESS
 - 3 S42 USED ON UNITS WITH 10HP MOTORS
 - 4 P431 MAY ONLY BE USED WHEN BLOWER IS CONFIGURED FOR CAV OPERATION

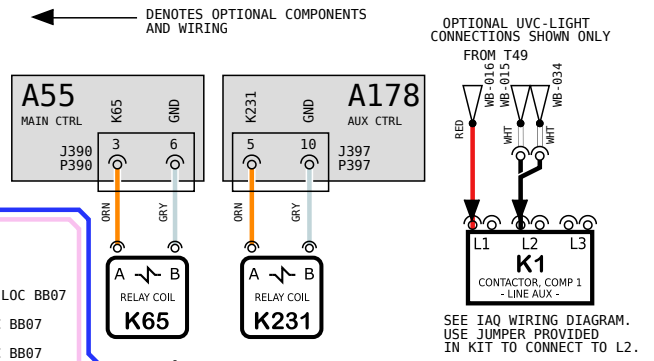

WARNING

DISCONNECT ALL POWER BEFORE SERVICING.

ELECTRIC SHOCK HAZARD. CAN CAUSE INJURY OR DEATH. UNIT MUST BE GROUNDED IN ACCORDANCE WITH NATIONAL AND LOCAL CODES.

FOR USE WITH COPPER CONDUCTORS ONLY. REFER TO UNIT RATING PLATE FOR MINIMUM CIRCUIT AMPACITY AND MAXIMUM OVERCURRENT PROTECTION SIZE.

IF ANY WIRE IN THIS APPLIANCE IS REPLACED, IT MUST BE REPLACED WITH WIRE OF LIKE SIZE, RATING AND INSULATION THICKNESS.

Model: LGT, LCT 210H - G, J-VOLT
COOLING - MSAV WITH BYPASS - 4 COMPRESSORS 4 CONDENSER FANS

Voltage: 460V/3~/60Hz (G), 575V/3~/60Hz (J)
Supersedes: N/A Form No: 538228-01 Rev: 1

© 2019

| HEATING SECTION A | COOLING SECTION B | COOLING SECTION B3 | ACCS SECTION C | ACCS SECTION D |
|-------------------|-------------------|--------------------|----------------|----------------|
|-------------------|-------------------|--------------------|----------------|----------------|

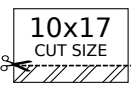

| REV | EC NO. | DATE | BY | APVD | REVISION NOTE |
|-----|------------|------------|------|-------|---|
| --- | CN-010356 | 06-20-2022 | MXR6 | JAL21 | ORIGINATED AT PD&R CARROLLTON, TX |
| 001 | CN-010356E | 07-26-2022 | MXR6 | JAL21 | A) REVERSED HIGH VOLTAGE WIRING ON T18 TRANSFORMER. |