

PACKAGEDS UNIT KITS AND ACCESSORIES

507316-03
3/2023
507316-02

BLOWER HOUSING REPLACEMENT KIT

INSTALLATION INSTRUCTIONS FOR BLOWER HOUSING REPLACEMENT KIT USED WITH LG/LC/LH/LD 078-150 UNITS

Shipping and Packing List

Package 1 of 1 contains:

- 1- Blower housing

⚠️ WARNING

Improper installation, adjustment, alteration, service or maintenance can cause property damage, personal injury or loss of life. Installation and service must be performed by a licensed professional HVAC installer or equivalent, service agency, or the gas supplier

⚠️ CAUTION

As with any mechanical equipment, contact with sharp sheet metal edges can result in personal injury. Take care while handling this equipment and wear gloves and protective clothing.

Application

The blower housing replacement kit is used on LG/LC/LH/LD 078-150 units. See table 1.

TABLE 1

Unit	Cat. No.	Assembly No.
LGM/LCM	24G29	612793-25
LGM/LCM	24G30*	612793-26
LGT/LCT/LHT/LDT	24G37	612793-27
LGT/LCT/LHT/LDT	24G28*	612793-28

*Corrosion protection

Remove Housing

- 1- Disconnect electrical power to unit. Wait five minutes before continuing service procedures to avoid electrical shock. This will allow internal capacitors time to fully discharge.
- 2- Open access panels as shown in figure 1.
- 3- Disconnect B3 Modbus connection and PT6 connection in the blower section. See figure 2.
- 4- Disconnect P48 in the controls area. See figure 3.
- 5- Cut wire ties where necessary and pull P48 wiring harness from control area into blower section.

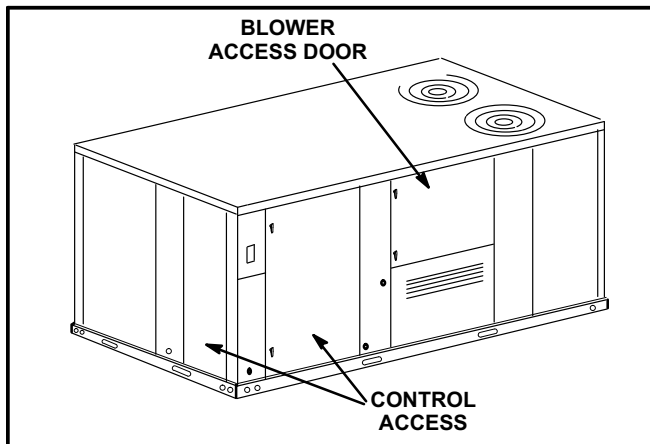

FIGURE 1

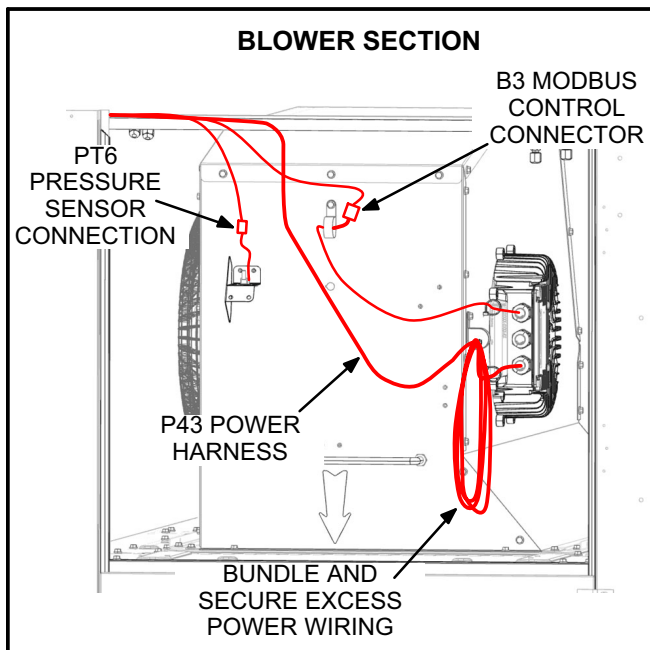

FIGURE 2

⚠️ WARNING

To prevent serious injury or death:

- 1- Lock-out/tag-out before performing maintenance.
- 2- If system power is required (e.g., smoke detector maintenance), disable power to blower, remove fan belt where applicable, and ensure all controllers and thermostats are set to the "OFF" position before performing maintenance.
- 3- Always keep hands, hair, clothing, jewelry, tools, etc., away from moving parts.



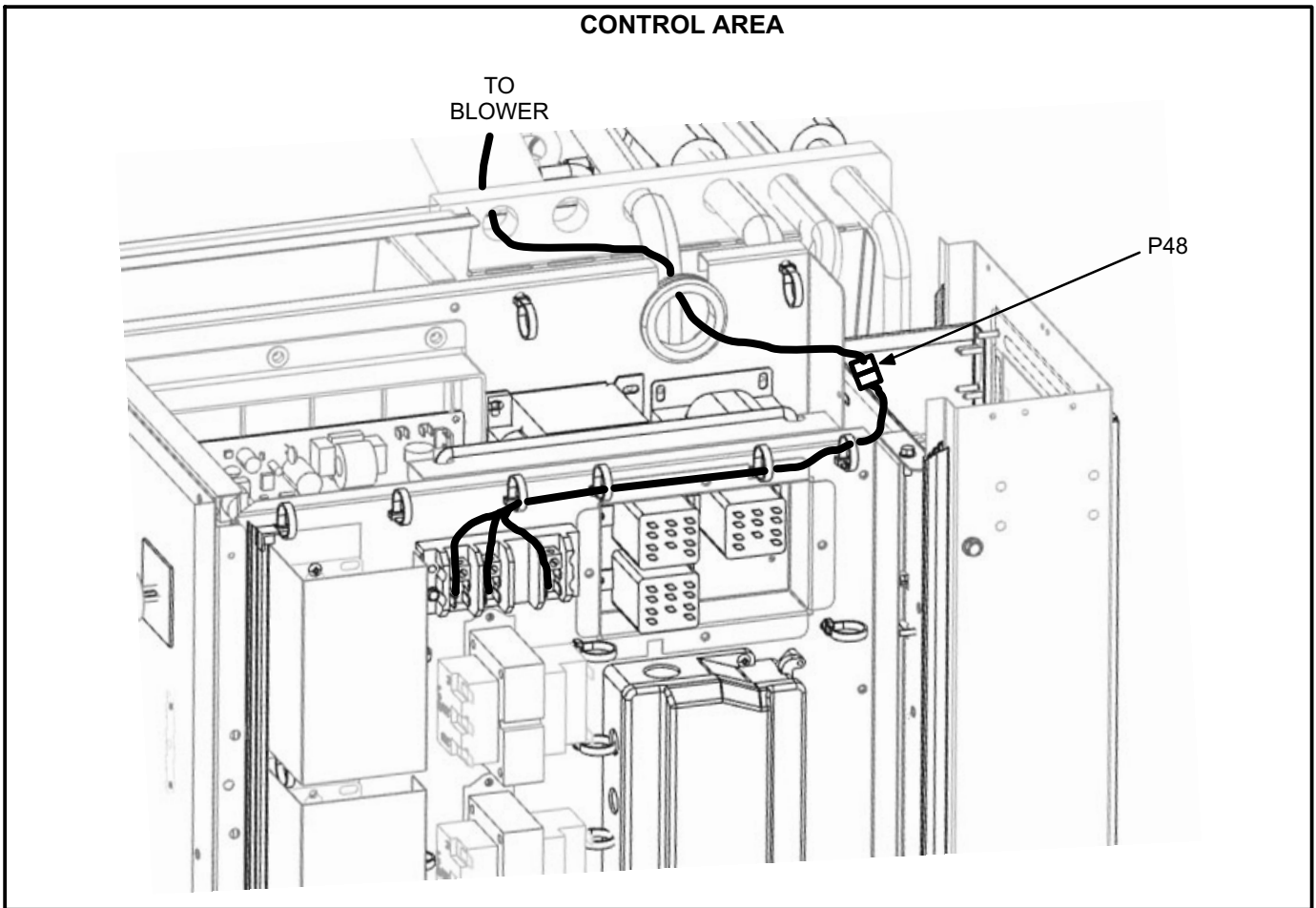

FIGURE 3

- 6- Remove four screws securing blower assembly to unit. See figure 5.
- 7- Disconnect the pressure tubing from PT6 pressure sensor. See figure 4. Remove two screws and remove sensor/bracket assembly (note the orientation). Remove PT6 from existing blower housing and save to be installed on the replacement housing.
- 8- If unit was equipped with an optional blower proving switch, remove and retain switch from existing blower housing. Retained switch will be installed on the replacement housing.
- 9- Use the handle on the blower assembly to slide the assembly out of unit.
- 10- Turn the blower assembly upside down. See figure 6.
- 11- Route the disconnected end of the pressure tubing through the grommet to the inside of the housing.
- 12- Carefully remove the inlet grill, orifice with tubing attached, and the side of the housing shown in figure 7.

- 13- Remove the motor / impeller secured to the existing housing. See figures 6 and 7.
- 14- Discard existing housing.

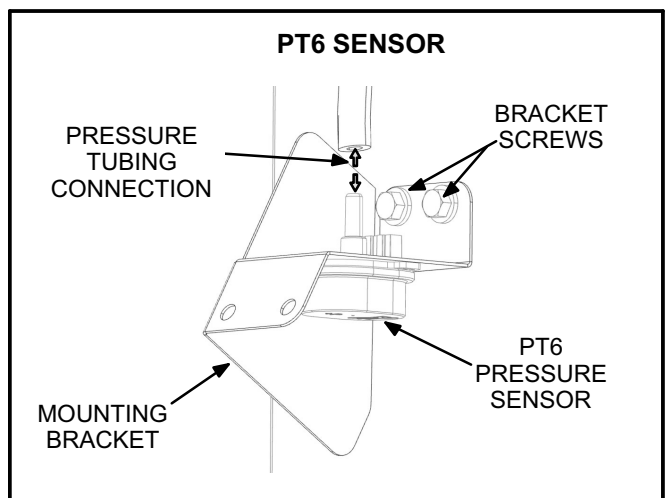

FIGURE 4

SLIDE BLOWER ASSEMBLY OUT OF UNIT

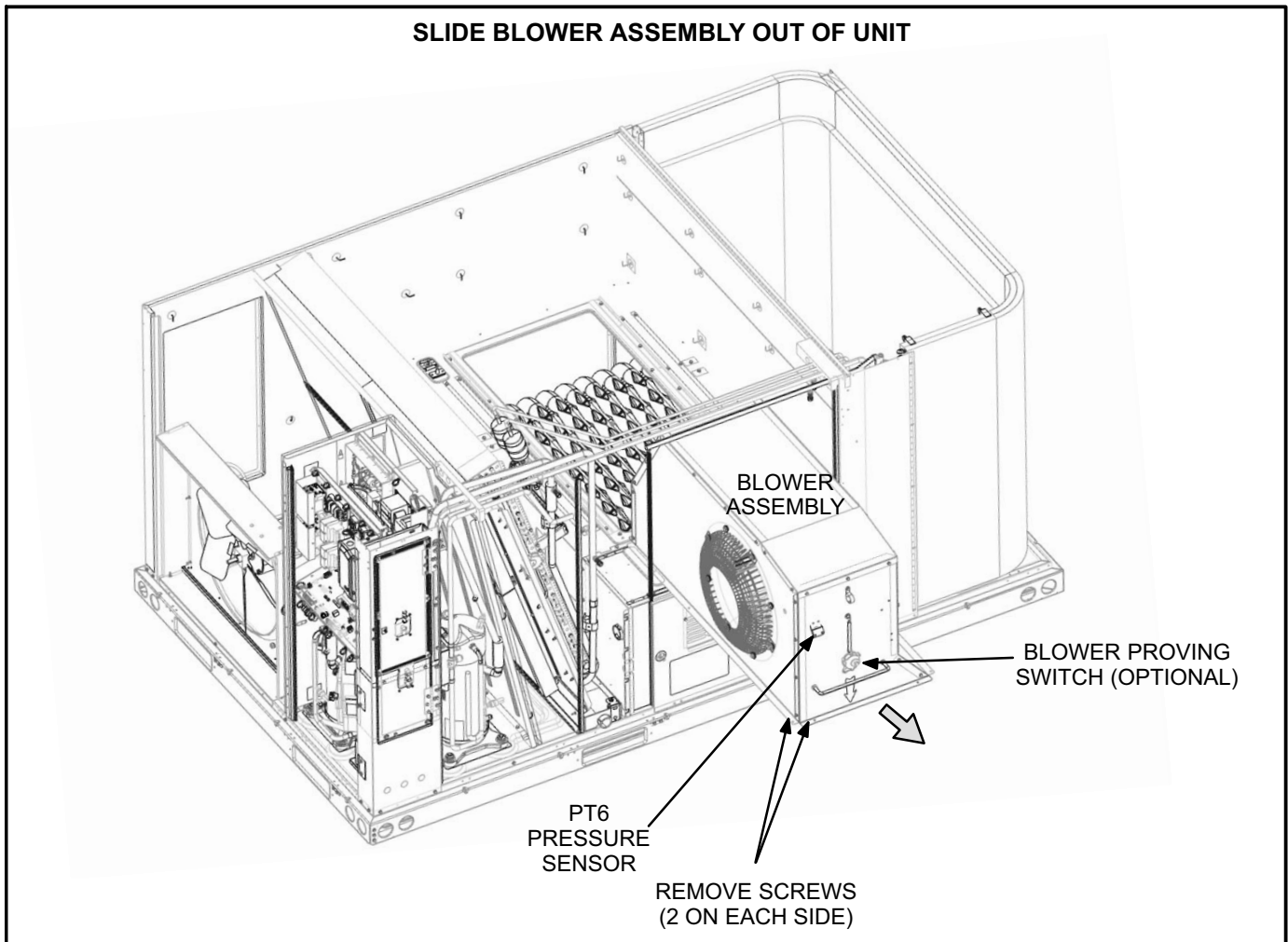

FIGURE 5

Install Replacement Housing

- 1- Remove one side of the replacement housing. See figures 6 and 7.
- 2- Carefully feed existing motor wire harnesses through the motor mounting hole in housing. Install existing motor / impeller on replacement blower housing in the same manner the motor / impeller was removed from the discarded housing. Secure with 8 bolts provided in this kit. Tighten to 21.7 ft.-lbs.
- 3- Replace the blower housing side, orifice with tubing attached, and inlet grill which was previously disassembled. Tighten orifice screws to 10.8 ft.-lbs. Tighten inlet grill screws to 3.7 ft.-lbs.
- 4- Route the disconnected end of the pressure tubing through the grommet to the outside of the housing. Make sure the tube is fully connected to the barb fitting on the orifice ring. Avoid tight bends in the tubing.
- 5- Re-install the sensor/bracket (note the orientation). Re-connect the pressure tubing to PT6 pressure sensor and avoid tight bends in the tubing. See figure 4.
- 6- If previously removed, attach the optional blower proving switch to replacement housing in the same manner it was removed.
- 7- Install blower assembly flanges into rails on the blower deck in the same manner the discarded housing was removed. Secure into place using four screws shown in figure 5.
- 8- Route P48 end of harness through unit to control area in the same manner as it was removed.
- 9- Connect P48, B3 Modbus, and PT6 connections as shown in figures 2 and 3.
- 10- Bundle harnesses and use wire ties to secure kit harnesses to unit harnesses in the same manner they were removed.

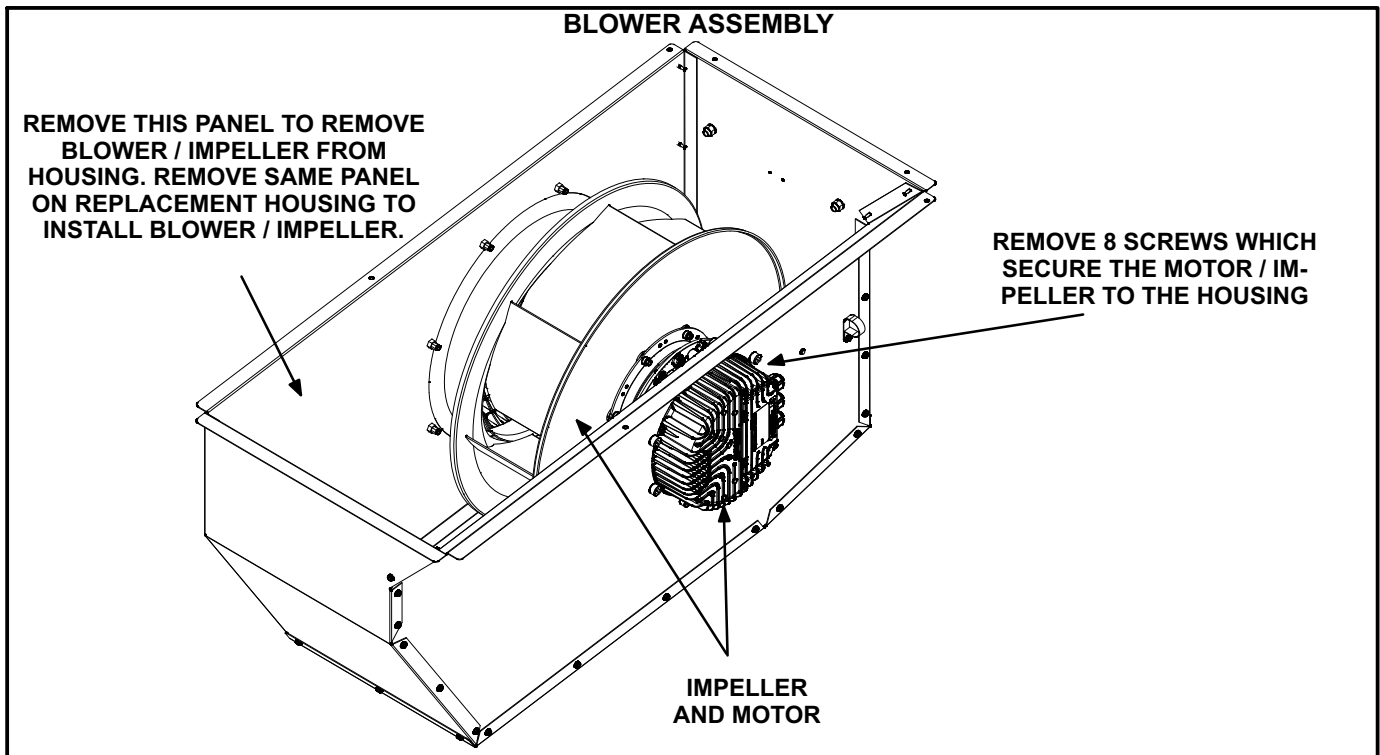

FIGURE 6

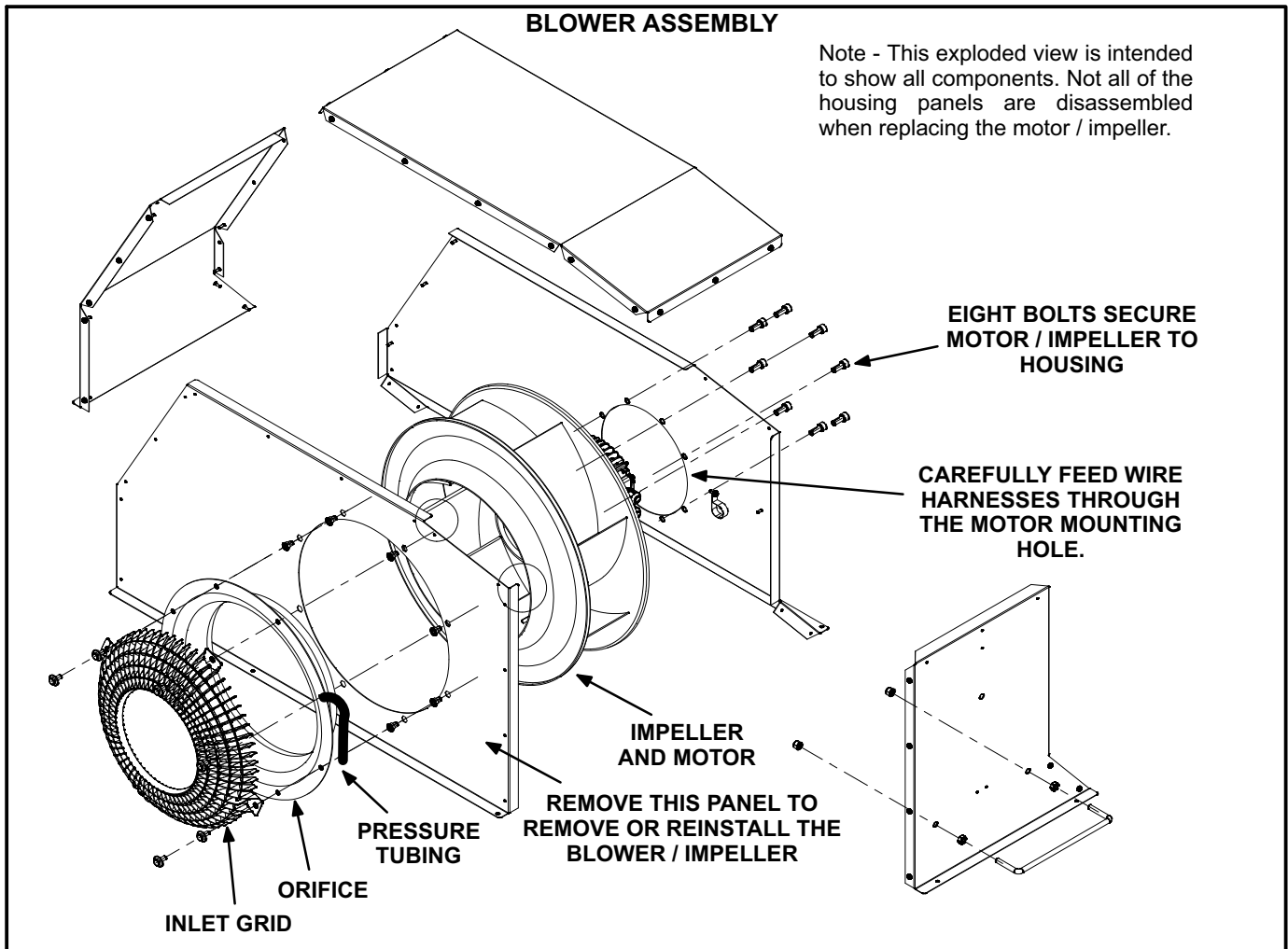

FIGURE 7