



538213-01

01

02

03

04

05

06

07

08

09

10

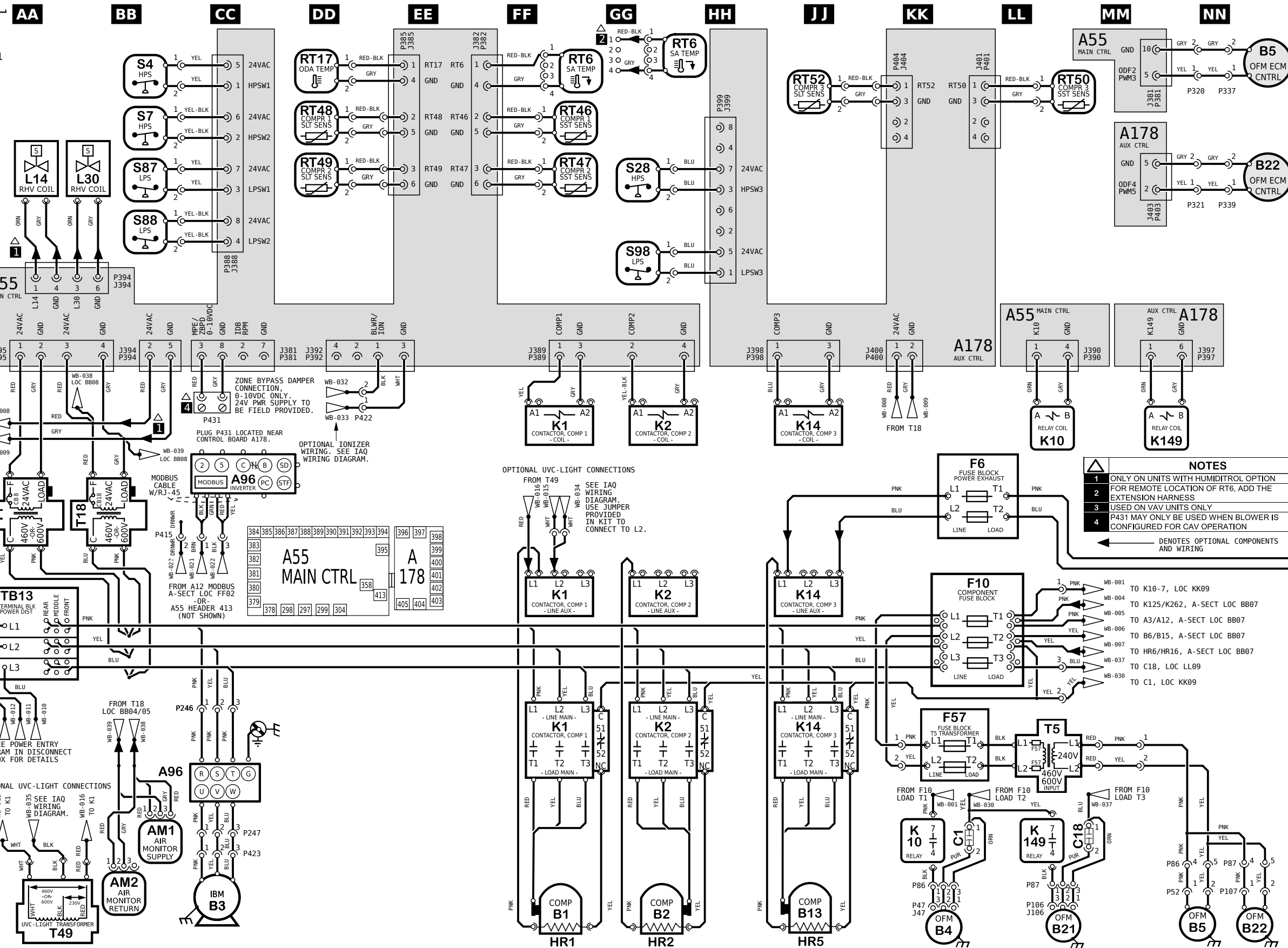

KEY LIST		
LOCATION	COMPONENT DESCRIPTION	
SS06	A30	TRANSDUCER, SA DUCT PRESSURE
CC05/08	A96	CONTROL INVERTER, BLOWER
BB09	AM1, AM2	AIR MONITOR, SUPPLY/RETURN, IAQ-TVOC
FF/GG/JJ10	B1, B2, B13	COMPRESSOR 1, 2, 3
CC10	B3	MOTOR, BLOWER
KK10, PP01/NN10	B4, B5	MOTOR, OUTDOOR FAN 1, 2
LL10, PP02/NN10	B21, B22	MOTOR, OUTDOOR FAN 3, 4
QQ09	B10, B11	MOTOR, EXHAUST FAN 1, 2
KK09	C1	CAPACITOR, OUTDOOR FAN 1
LL09	C18	CAPACITOR, OUTDOOR FAN 3
QQ09	C6, C8	CAPACITOR, EXHAUST FAN 1, 2
LL05	F6	FUSE, EXHAUST FAN
LL07	F10	FUSE, COMPONENT
LL08	F57	FUSE, T5 TRANSFORMER PRIMARY
FF/GG/JJ10	HR1, HR2, HR5	HEATER, COMPRESSOR 1, 2, 3
FF05,06,08	K1	CONTACTOR, COMPRESSOR 1
GG/JJ05,08,08	K2, K14	CONTACTOR, COMPRESSOR 2, 3
LL05/LL09	K10	RELAY, OUTDOOR FAN 1
MM05/LL09	K149	RELAY, OUTDOOR FAN 3
QQ07	K65, K231	RELAY, EXHAUST FAN 1, 2
AA02	L14, L30	VALVE, SOLENOID, REHEAT COIL 1, 2
GG01	RT6	SENSOR, A55 DISCHARGE (IMC)
DD01	RT17	SENSOR, OUTSIDE AIR TEMP
GG02,MM01	RT46, RT47, RT50	SENSOR, SAT. SUCT TEMP., COMP 1, 2, 3
DD02, JJ01	RT48, RT49, RT52	SENSOR, SAT. LIQUID TEMP., COMP 1, 2, 3
BB01/02, GG02	S4, S7, S28	LIMIT, HI PRESS. SWITCH, COMP 1, 2, 3
BB02, GG03	S87, S88, S98	SWITCH, LOW PRESS., COMP. 1, 2, 3
AA06	T1	TRANSFORMER, CONTROL
MM08	T5	TRANSFORMER, OUTDOOR FAN MOTOR
BB06	T18	TRANSFORMER, CONTACTOR
AA10	T49	TRANSFORMER, UVC-LIGHT POWER
AA07	TB13	TERMINAL STRIP, POWER DISTRIBUTION

NOTES

- 1 ONLY ON UNITS WITH HUMIDITROL OPTION
- 2 FOR REMOTE LOCATION OF RT6, ADD THE EXTENSION HARNESS
- 3 USED ON VAV UNITS ONLY
- 4 P431 MAY ONLY BE USED WHEN BLOWER IS CONFIGURED FOR CAV OPERATION

▲ DENOTES OPTIONAL COMPONENTS AND WIRING

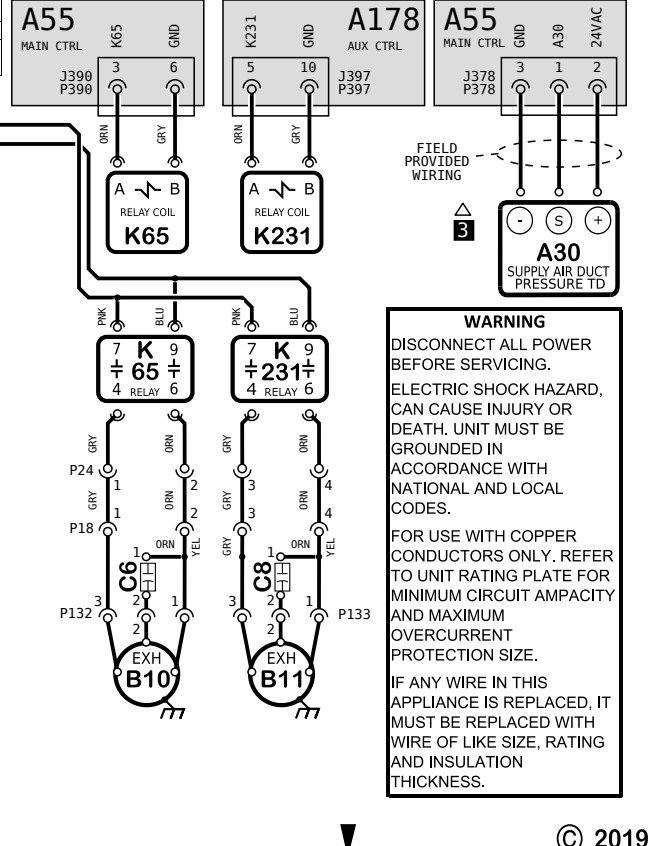

WARNING

DISCONNECT ALL POWER BEFORE SERVICING.

ELECTRIC SHOCK HAZARD. CAN CAUSE INJURY OR DEATH. UNIT MUST BE GROUNDED IN ACCORDANCE WITH NATIONAL AND LOCAL CODES.

FOR USE WITH COPPER CONDUCTORS ONLY. REFER TO UNIT RATING PLATE FOR MINIMUM CIRCUIT AMPACITY AND MAXIMUM OVERCURRENT PROTECTION SIZE.

IF ANY WIRE IN THIS APPLIANCE IS REPLACED, IT MUST BE REPLACED WITH WIRE OF LIKE SIZE, RATING AND INSULATION THICKNESS.

Model: LGT, LCT 180H - G, J-VOLT
 COOLING - MSAV NO BYPASS -OR- VAV - 3 COMPRESSORS 4 CONDENSER FANS

Voltage: 460V/3~60Hz (G), 575V/3~60Hz (J)
 Supersedes: N/A Form No: 538213-01 Rev: 1

© 2019

HEATING SECTION A	COOLING SECTION B	COOLING SECTION B3	ACCS SECTION C	ACCS SECTION D
-------------------	-------------------	--------------------	----------------	----------------

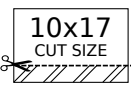

REV	EC NO.	DATE	BY	APVD	REVISION NOTE
---	CN-010356	06-20-2022	MXR6	JAL21	ORIGINATED AT PD&R CARROLLTON, TX
001	CN-010356E	07-26-2022	MXR6	JAL21	A) REVERSED HIGH VOLTAGE WIRING ON T18 TRANSFORMER.



538213-01
01

02

03

04

05

06

07

08

09

10

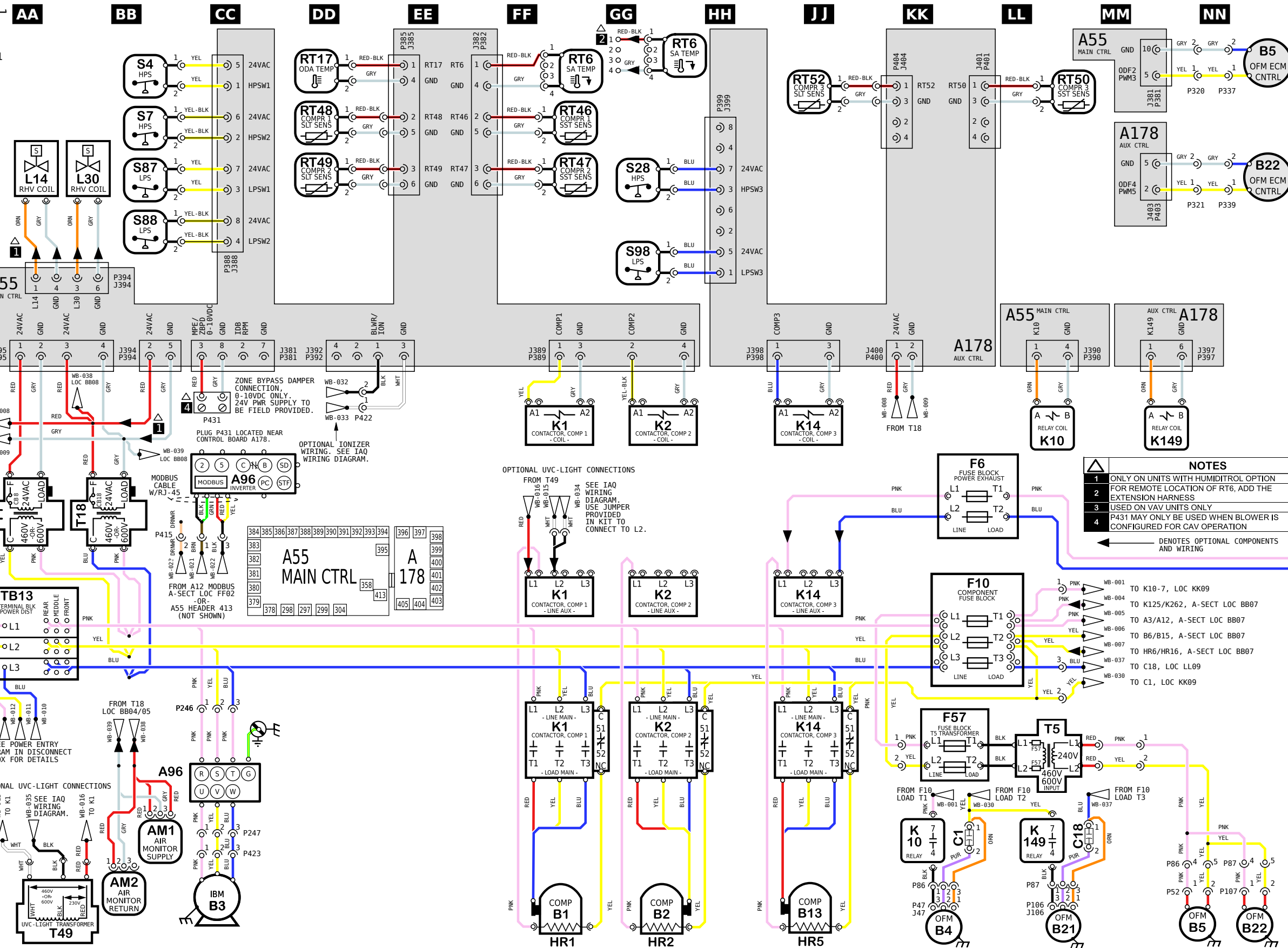

KEY LIST		
LOCATION	COMPONENT DESCRIPTION	
SS06	A30	TRANSDUCER, SA DUCT PRESSURE
CC05/08	A96	CONTROL INVERTER, BLOWER
BB09	AM1, AM2	AIR MONITOR, SUPPLY/RETURN, IAQ-TVOC
FF/GG/JJ10	B1, B2, B13	COMPRESSOR 1, 2, 3
CC10	B3	MOTOR, BLOWER
KK10, PP01/NN10	B4, B5	MOTOR, OUTDOOR FAN 1, 2
LL10, PP02/NN10	B21, B22	MOTOR, OUTDOOR FAN 3, 4
QQ09	B10, B11	MOTOR, EXHAUST FAN 1, 2
KK09	C1	CAPACITOR, OUTDOOR FAN 1
LL09	C18	CAPACITOR, OUTDOOR FAN 3
QQ09	C6, C8	CAPACITOR, EXHAUST FAN 1, 2
LL05	F6	FUSE, EXHAUST FAN
LL07	F10	FUSE, COMPONENT
LL08	F57	FUSE, T5 TRANSFORMER PRIMARY
FF/GG/JJ10	HR1, HR2, HR5	HEATER, COMPRESSOR 1, 2, 3
FF05,06,08	K1	CONTACTOR, COMPRESSOR 1
GG/JJ05,08,08	K2, K14	CONTACTOR, COMPRESSOR 2, 3
LL05/LL09	K10	RELAY, OUTDOOR FAN 1
MM05/LL09	K149	RELAY, OUTDOOR FAN 3
QQ07	K65, K231	RELAY, EXHAUST FAN 1, 2
AA02	L14, L30	VALVE, SOLENOID, REHEAT COIL 1, 2
GG01	RT6	SENSOR, A55 DISCHARGE (IMC)
DD01	RT17	SENSOR, OUTSIDE AIR TEMP
GG02,MM01	RT46, RT47, RT50	SENSOR, SAT. SUCT TEMP., COMP 1, 2, 3
DD02, JJ01	RT48, RT49, RT52	SENSOR, SAT. LIQUID TEMP., COMP 1, 2, 3
BB01/02, GG02	S4, S7, S28	LIMIT, HI PRESS. SWITCH, COMP 1, 2, 3
BB02, GG03	S87, S88, S98	SWITCH, LOW PRESS., COMP. 1, 2, 3
AA06	T1	TRANSFORMER, CONTROL
MM08	T5	TRANSFORMER, OUTDOOR FAN MOTOR
BB06	T18	TRANSFORMER, CONTACTOR
AA10	T49	TRANSFORMER, UVC-LIGHT POWER
AA07	TB13	TERMINAL STRIP, POWER DISTRIBUTION

NOTES

- 1 ONLY ON UNITS WITH HUMIDITROL OPTION
- 2 FOR REMOTE LOCATION OF RT6, ADD THE EXTENSION HARNESS
- 3 USED ON VAV UNITS ONLY
- 4 P431 MAY ONLY BE USED WHEN BLOWER IS CONFIGURED FOR CAV OPERATION

▲ DENOTES OPTIONAL COMPONENTS AND WIRING

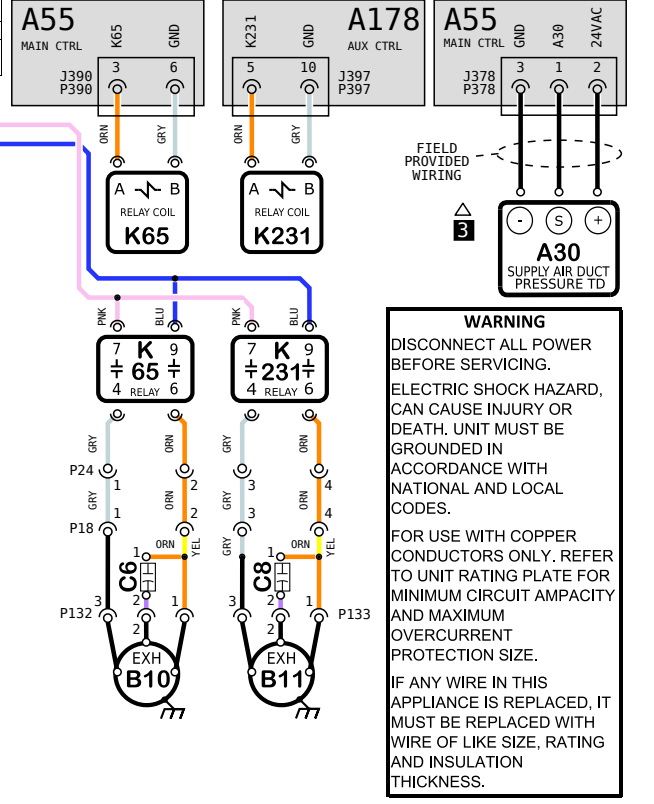

WARNING

DISCONNECT ALL POWER BEFORE SERVICING.

ELECTRIC SHOCK HAZARD. CAN CAUSE INJURY OR DEATH. UNIT MUST BE GROUNDED IN ACCORDANCE WITH NATIONAL AND LOCAL CODES.

FOR USE WITH COPPER CONDUCTORS ONLY. REFER TO UNIT RATING PLATE FOR MINIMUM CIRCUIT AMPACITY AND MAXIMUM OVERCURRENT PROTECTION SIZE.

IF ANY WIRE IN THIS APPLIANCE IS REPLACED, IT MUST BE REPLACED WITH WIRE OF LIKE SIZE, RATING AND INSULATION THICKNESS.

Model: LGT, LCT 180H - G, J-VOLT
COOLING - MSAV NO BYPASS -OR- VAV - 3 COMPRESSORS 4 CONDENSER FANS

Voltage: 460V/3~60Hz (G), 575V/3~60Hz (J)
Supersedes: N/A Form No: 538213-01 Rev: 1

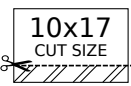
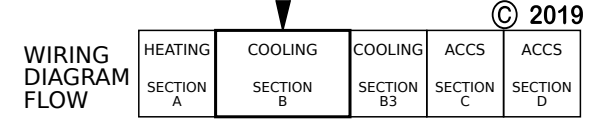

REV	EC NO.	DATE	BY	APVD	REVISION NOTE
---	CN-010356	06-20-2022	MXR6	JAL21	ORIGINATED AT PD&R CARROLLTON, TX
001	CN-010356E	07-26-2022	MXR6	JAL21	A) REVERSED HIGH VOLTAGE WIRING ON T18 TRANSFORMER.

© 2019