

**INSTALLATION INSTRUCTIONS FOR LOW AMBIENT KIT
USED ON ZG/ZC/ZH 036-150 PACKAGED ROOFTOP UNITS**

Shipping and Packing List

99W67 & 99W68 (page 1)

Package 1 of 1 contains:

- 1- Pressure switch (S11)
- 2- Wire harnesses
- 1- Valve depressor tee
- 1- Relay (K10 for ZC, ZG G, J, M; K58 for ZH units)
- 2- Dual terminals

Bag assembly containing:

- 2- Screws
- 1- Snap bushing

10Z34 (page 8)

Package 1 of 1 contains:

- 2- Pressure switches (S11 / 102312-01; S84 / 102312-02)
- 2- Wire harnesses
- 2- Wire ties
- 2- Valve depressor tees

Application

ZG/ZC 036-060 units use 99W67; 610195-07

ZH 036-060 units use 99W68; 610195-08

ZG/ZC/ZH 092-150 units use 10Z34; 612397-01

The low ambient pressure switches cycle the outdoor fan while allowing compressor operation in the cooling cycle. This intermittent fan operation results in a high evaporating temperature which allows the system to operate without icing the evaporator coil and losing capacity. This kit is designed for use in ambient temperatures no lower than 0°F (-17.8°C) unless otherwise noted in the Engineering Handbook.

Install a belly-band style crankcase heater on compressors which don't have one OR on compressors which don't have an internal heater.

Installation - 036-060

- 1- Disconnect power to unit. Open compressor access and control box panels.
- 2- Install valve depressor tee on liquid line pressure tap. See figure 1. Install pressure switch on pressure tap.

⚠ WARNING

Improper installation, adjustment, alteration, service or maintenance can cause property damage, personal injury or loss of life. Installation and service must be performed by a qualified installer, service agency or the gas supplier

⚠ CAUTION

Danger of sharp metallic edges. Can cause injury. Take care when servicing unit to avoid accidental contact with sharp edges.

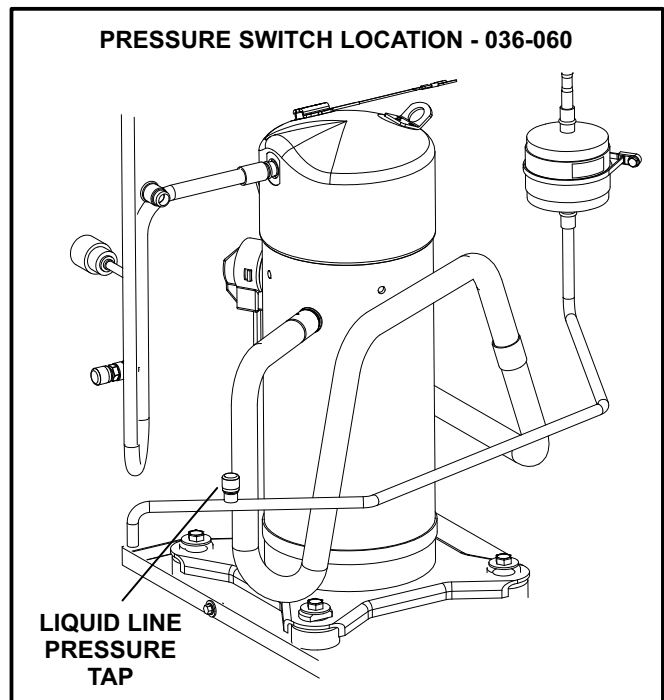

FIGURE 1

- 3- Check system for leaks.
- 4- Determine harness appropriate for application by type of unit and markings on harness wires. Connect leads labeled S11 to pressure switch.
- 5- Install snap bushing in outdoor coil support. See figure 2. Route harness as shown in figure 2.
- 6- *ZH Units Only* -
Install the kit relay in location shown in figure 3. Secure with screws provided in kit.

*Caution - Pressure switch is not rated for applications above 240V. Relay must be used in high voltage applications.

Installation - 036-060 continued

- 7- Make wiring connections as follows:
- | | | |
|------------------|-----------------|----------|
| ZG/ZC | Y, P Voltage | Figure 4 |
| ZG/ZC | G, J, M Voltage | Figure 5 |
| ZH | Y, P Voltage | Figure 6 |
| ZH | G, J, M Voltage | Figure 7 |
| Wiring Schematic | | Figure 8 |

- 8- Bundle wiring and secure wiring away from unit components.
- 9- Restore power to unit and close access panels.

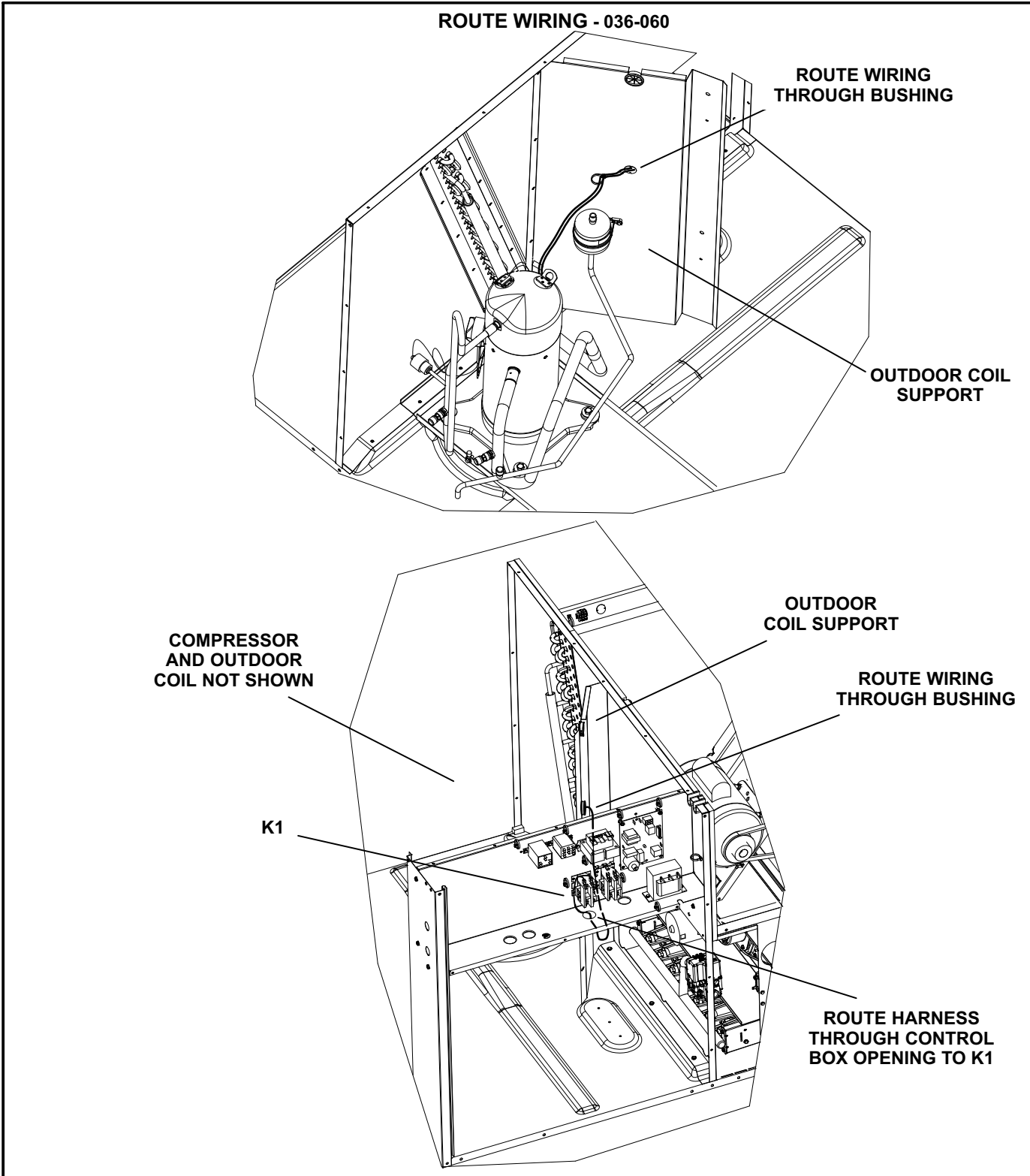

FIGURE 2

K58 RELAY LOCATION - ZH UNITS ONLY - 036-060

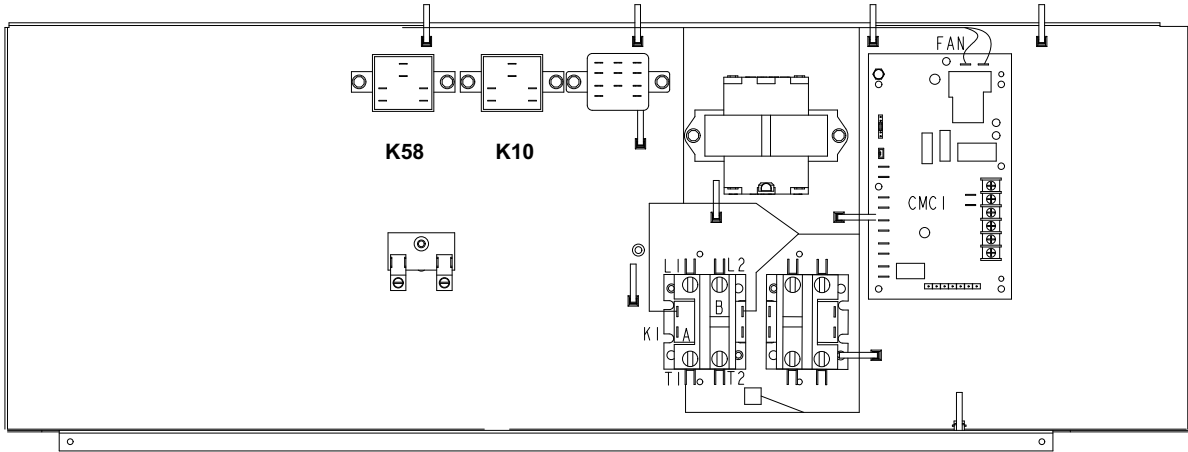

FIGURE 3

WIRING - ZG/ZC Y, P VOLT UNITS - 036-060

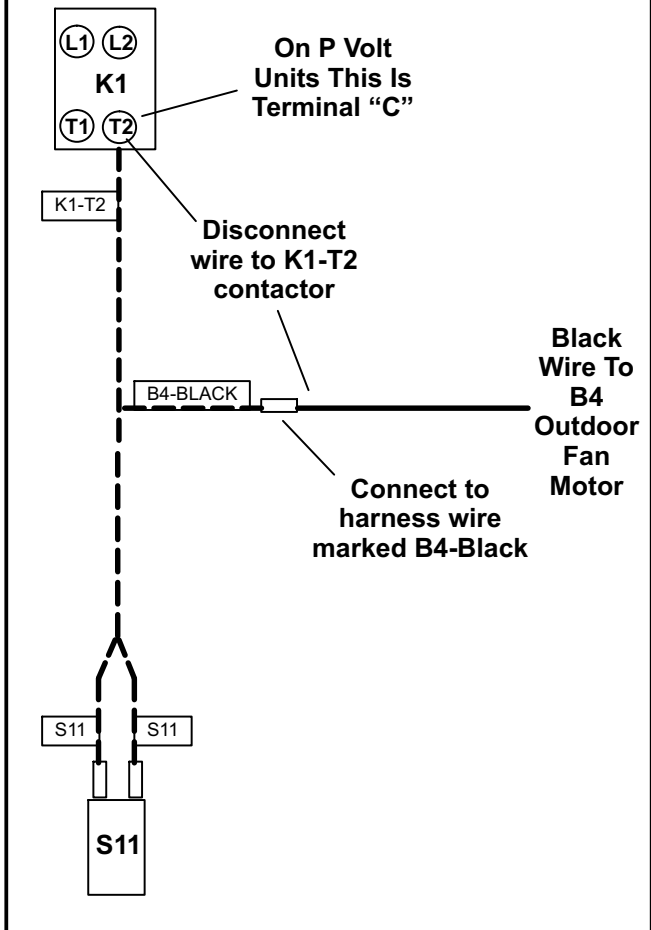

FIGURE 4

WIRING - ZG/ZC G, J, M VOLT UNITS - 036-060

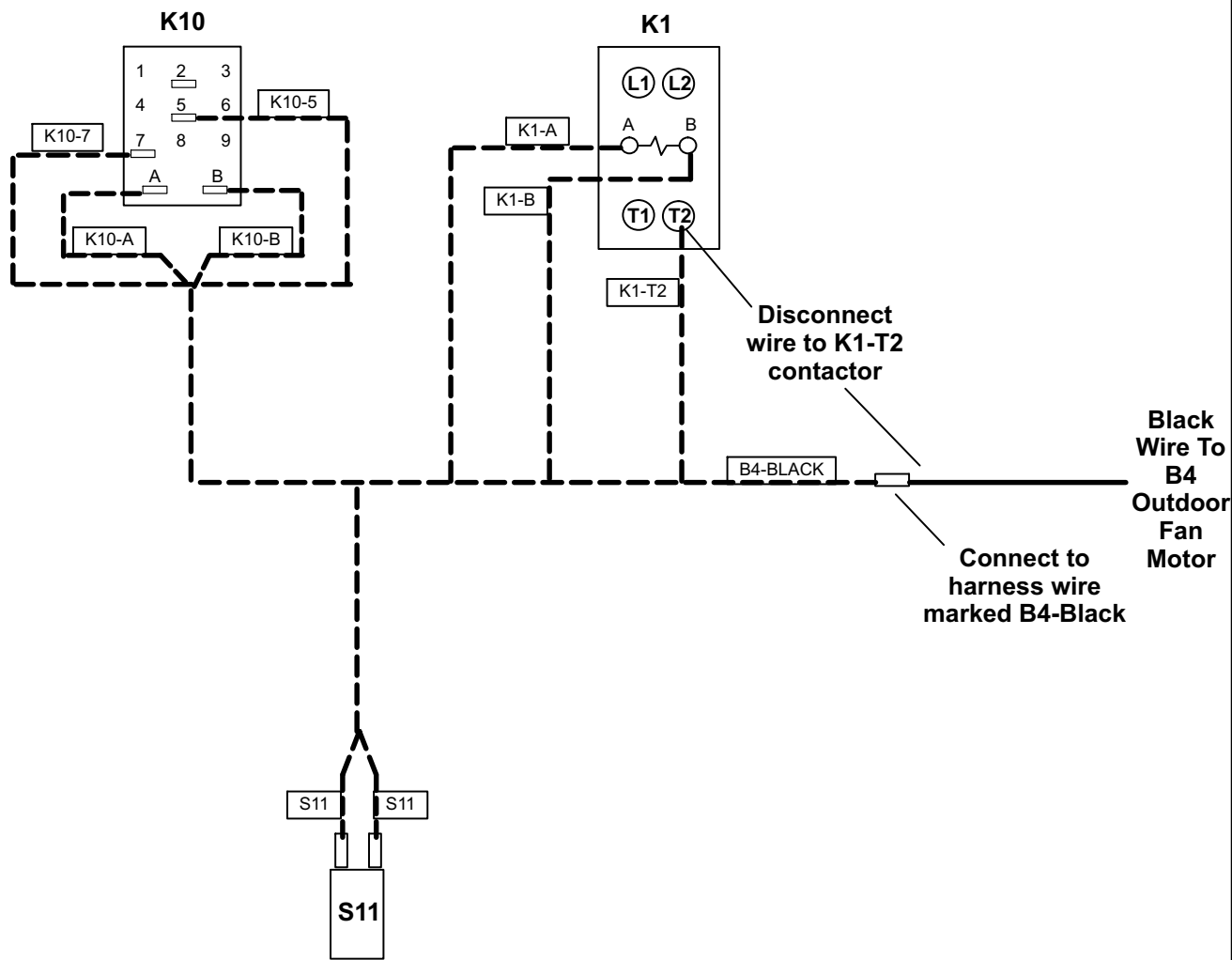

FIGURE 5

WIRING - ZH Y, P VOLT UNITS - 036-060

Remove the white wires marked CMC1-O.
Install dual terminals on CMC1-O terminals.
Reattach the white wires and the kit harness
wires marked CMC1-O on the dual terminals.

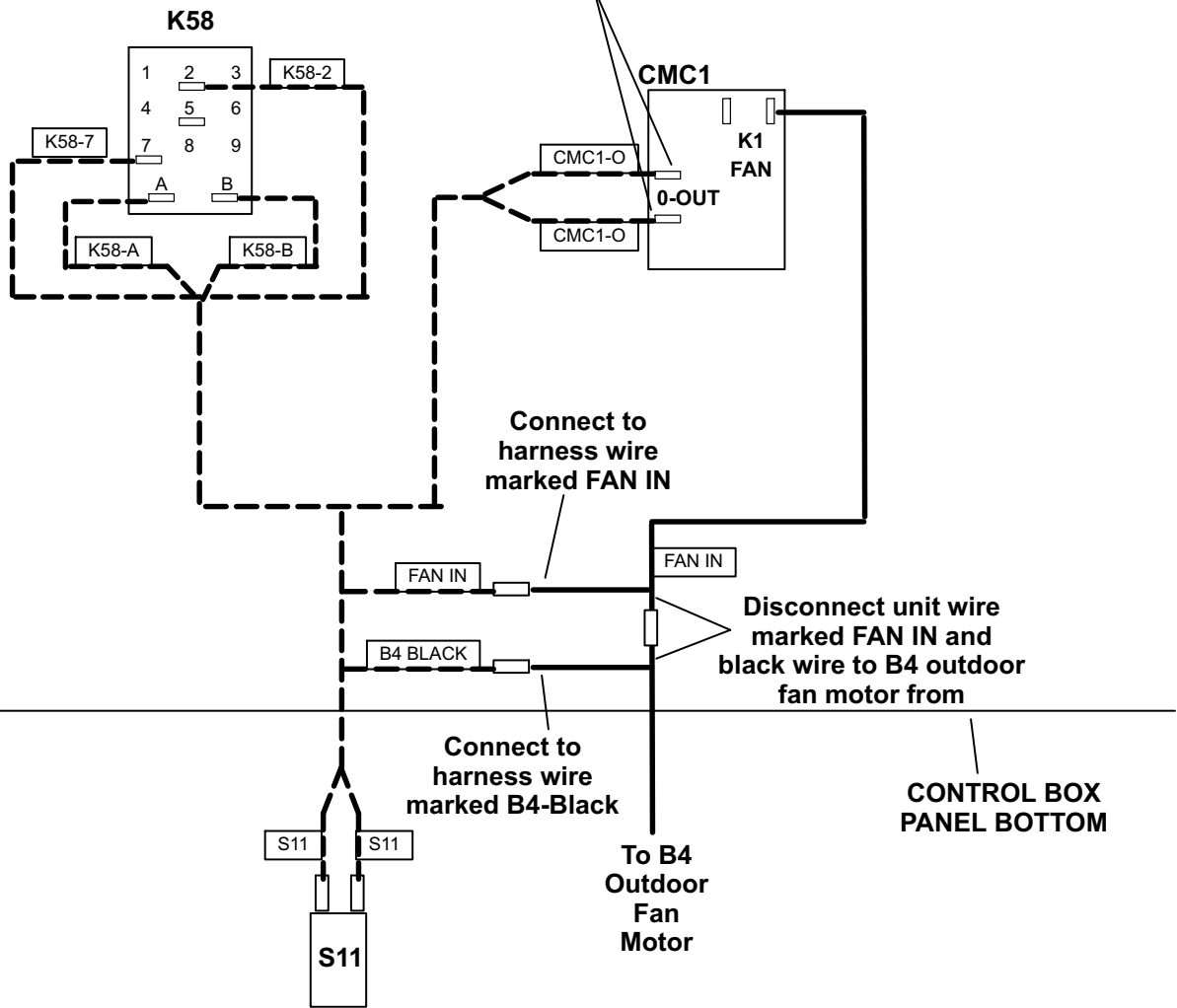

FIGURE 6

WIRING - ZH G, J, M VOLT UNITS - 036-060

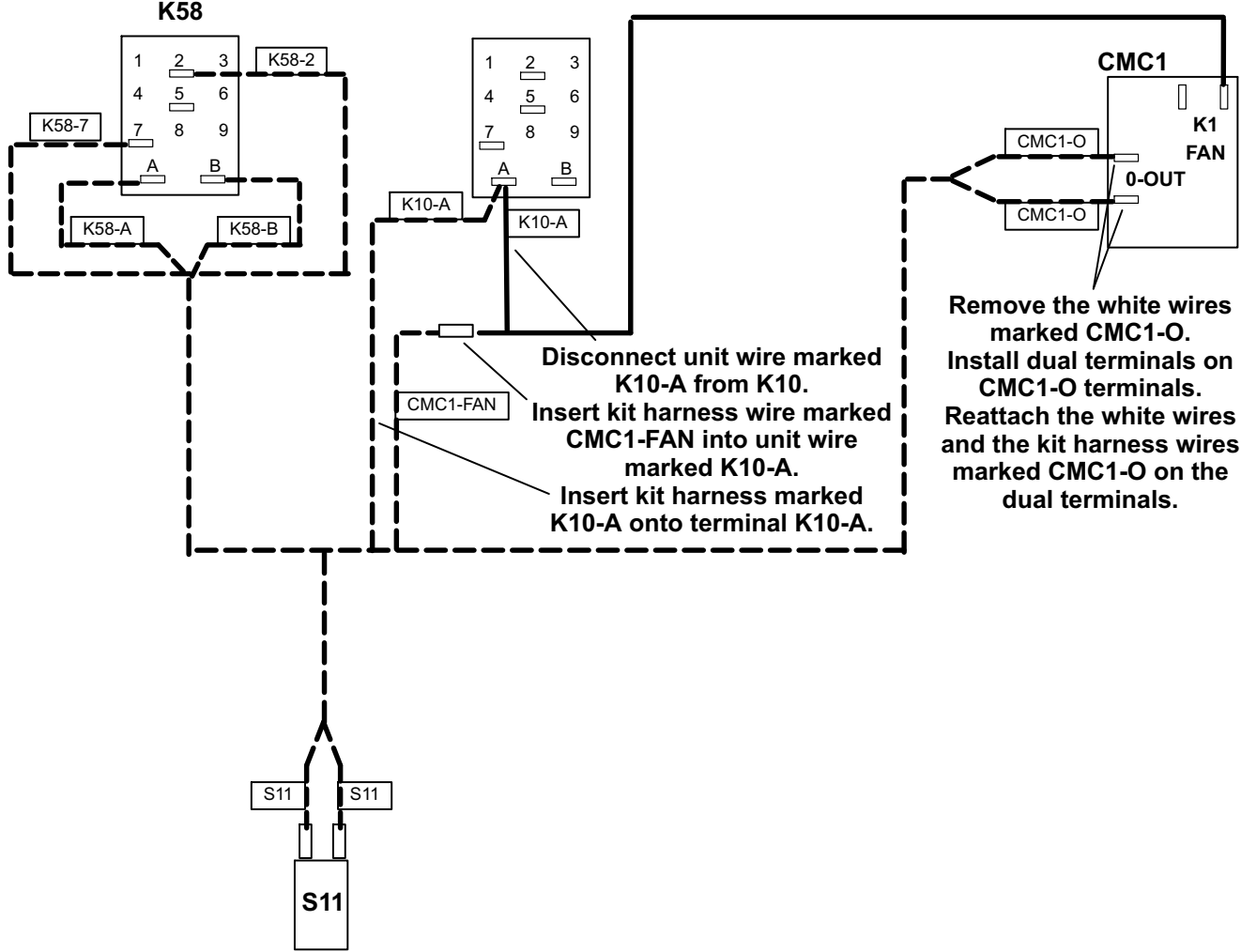

FIGURE 7

**WIRING DIAGRAM - ZCA, ZGA, ZHA036, 048, 060, 072
LOW AMBIENT KIT INSTALLED**

KEY	COMPONENT
B1	COMPRESSOR 1
B4	MOTOR, OUTDOOR FAN
C1	CAPACITOR, OUTDOOR1
C12	CAPACITOR, DUAL
CMC1	TIMER, DEFROST, COMPRESSOR 1
F1	FUSE, TRANSFORMER 1
J2	JACK, HEAT
J3	JACK, UNIT ECONOMIZER
K1	CONTACTOR, COMPRESSOR 1
K10	RELAY, OUTDOOR FAN 1
K58	RELAY, LOW AMBIENT KIT
L1	VALVE, REVERSING 1
N	NEUTRAL
S4	LIMIT, HI PRESS SWITCH, COMPRESSOR 1
S5	LIMIT, HI TEMP, COMPRESSOR 2
S11	SWITCH, LOW PRESS, LOW AMB KIT
T1	TRANSFORMER, CONTROL

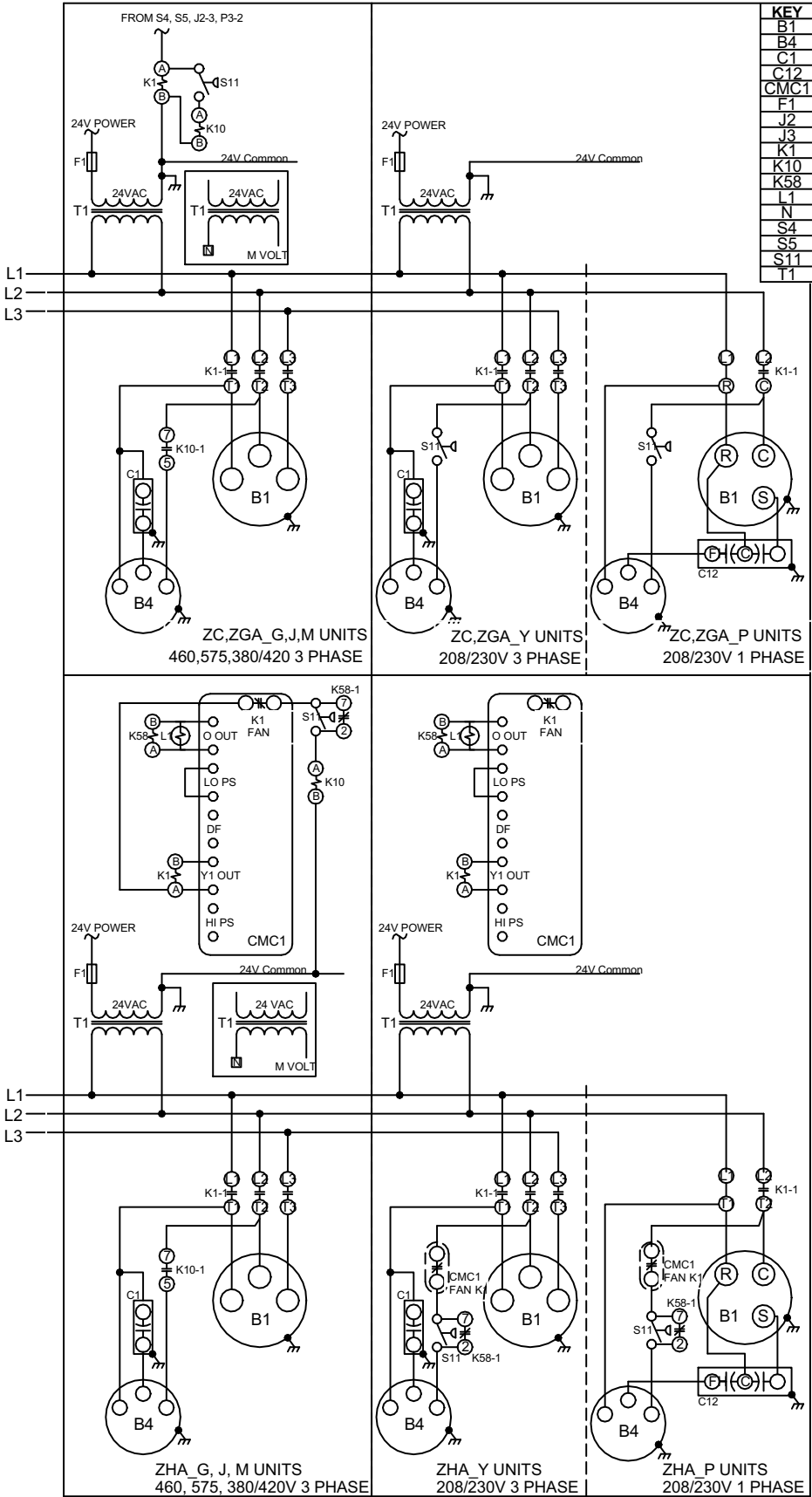

FIGURE 8

PRESSURE TAP LOCATION - ZG/ZC 092-150 UNITS

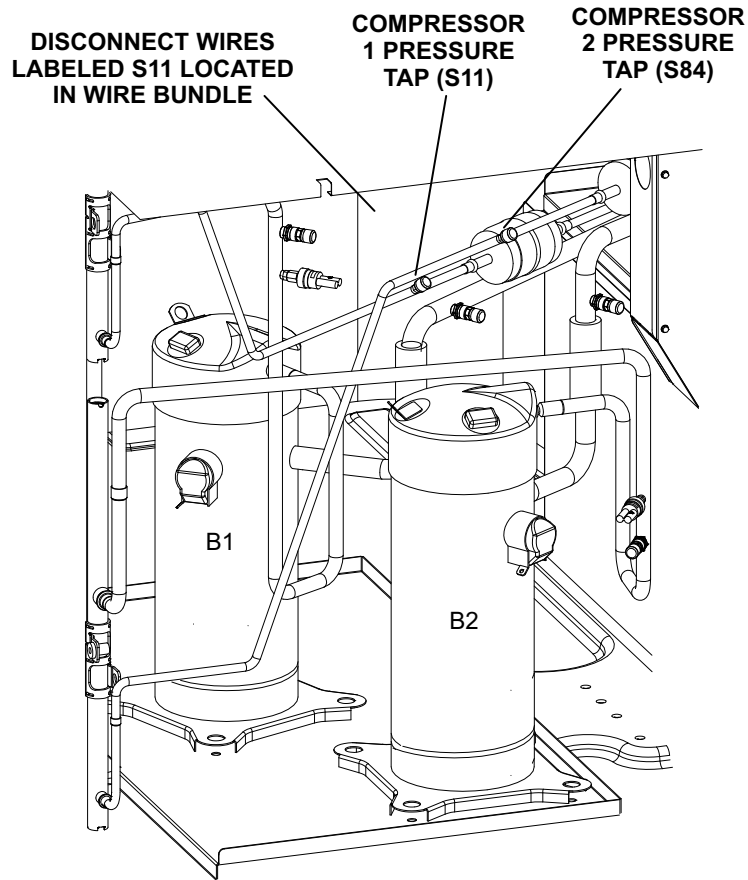

FIGURE 9

Installation - 092-150

- 1- Disconnect power to unit.
- 2- Install valve depressor tee on liquid line pressure taps. See figure 9 for ZG/ZC units and figure 10 for ZH units. Install pressure switches on valve depressor tee.
- 3- Check system for leaks.

PRESSURE TAP LOCATION ZH 092-150

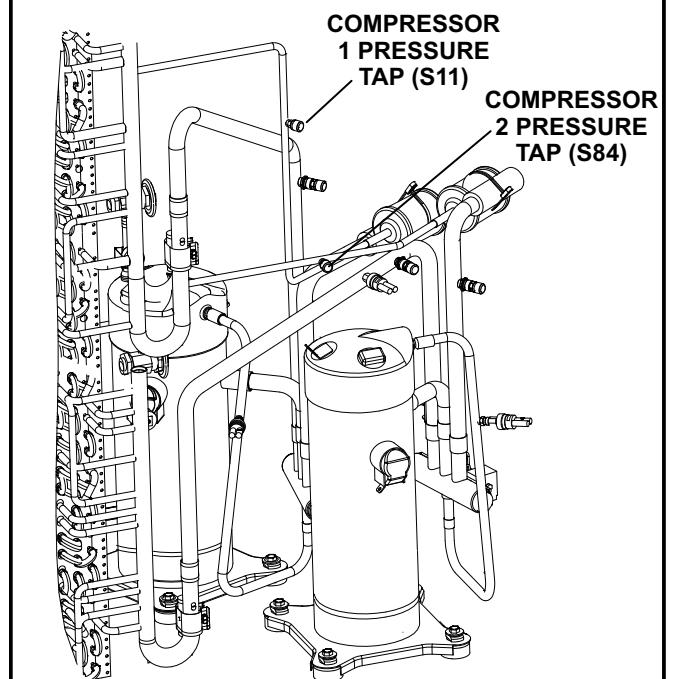

FIGURE 10

Wiring - ZG/ZC 092-150 Units

Refer to wiring schematic in figure 14.

- 1- Disconnect wires marked S11 as shown in figure 9.
- 2- Locate shorter kit harness and connect wires as shown in figure 11. Discard longer harness when installing a ZG or ZC unit.
- 3- Bundle wiring and secure away from unit components.

Wiring - ZH 092-120 Units

Refer to wiring schematic in figure 15.

- 1- Refer to figure 13 to make wiring connections.
- 2- Bundle wiring and secure away from unit components.

Operation

Outdoor fans will be energized when the liquid pressure rises to 450 psig (3103kPa) and de-energize when liquid pressure drops to 240 psig (1655kPa).

ZG/ZC/ZH 092-150 -

Outdoor fans cycle together (all switches must be open).

When heat pump units operate in heating mode, K58 bypasses S11 and S84 pressure switches to keep fans operating regardless of liquid pressure.

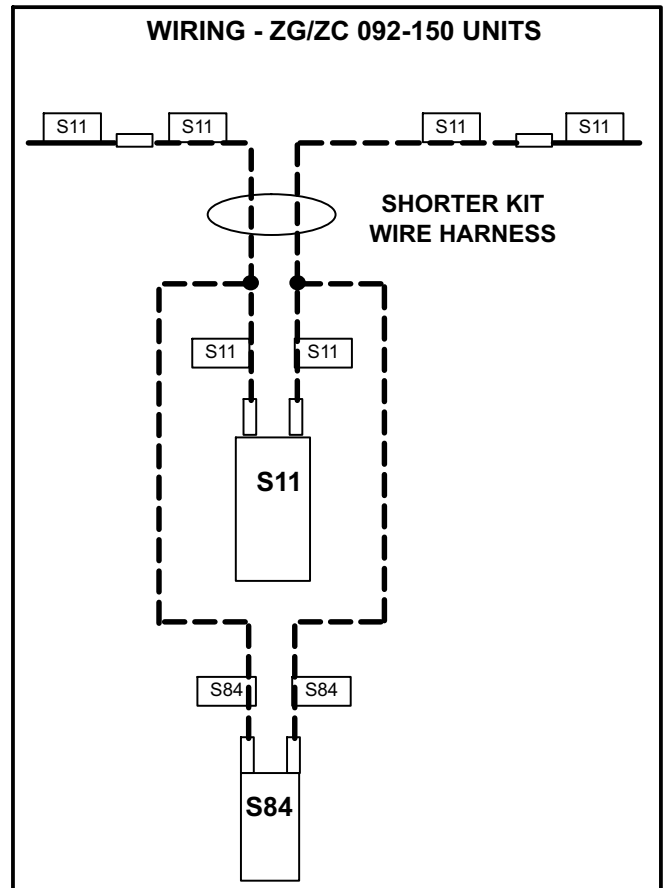

FIGURE 11

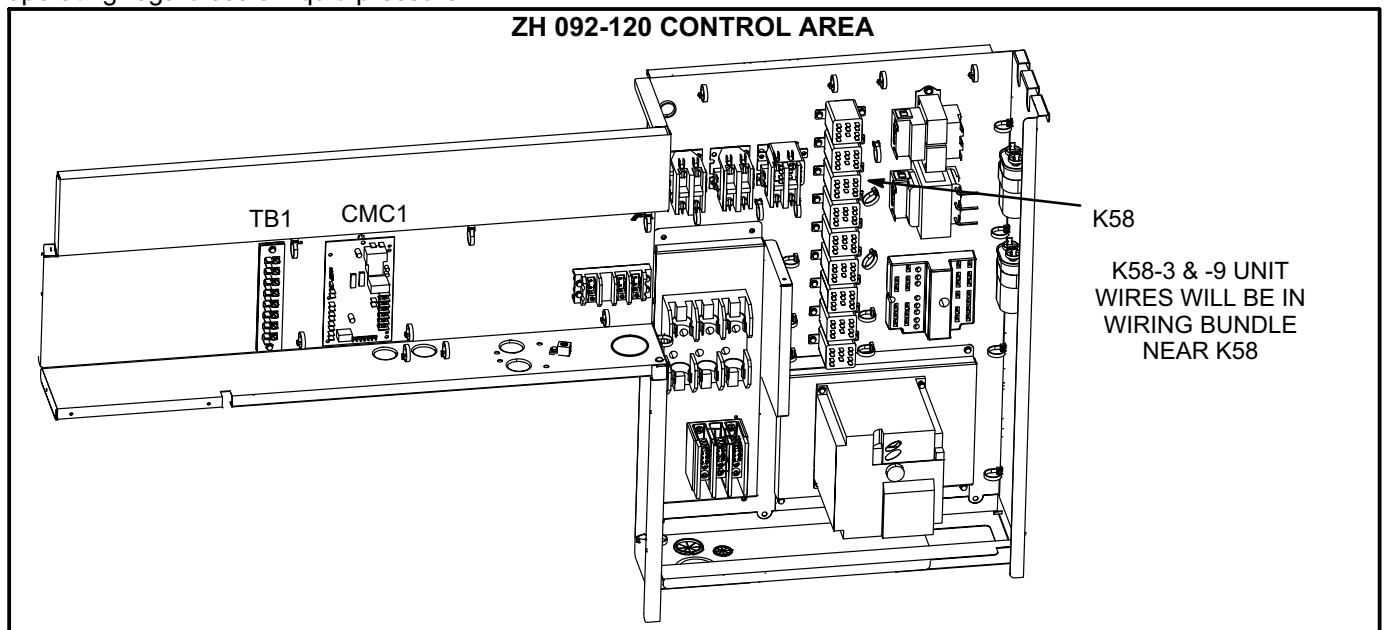

FIGURE 12

WIRING - ZH 092-120 UNITS

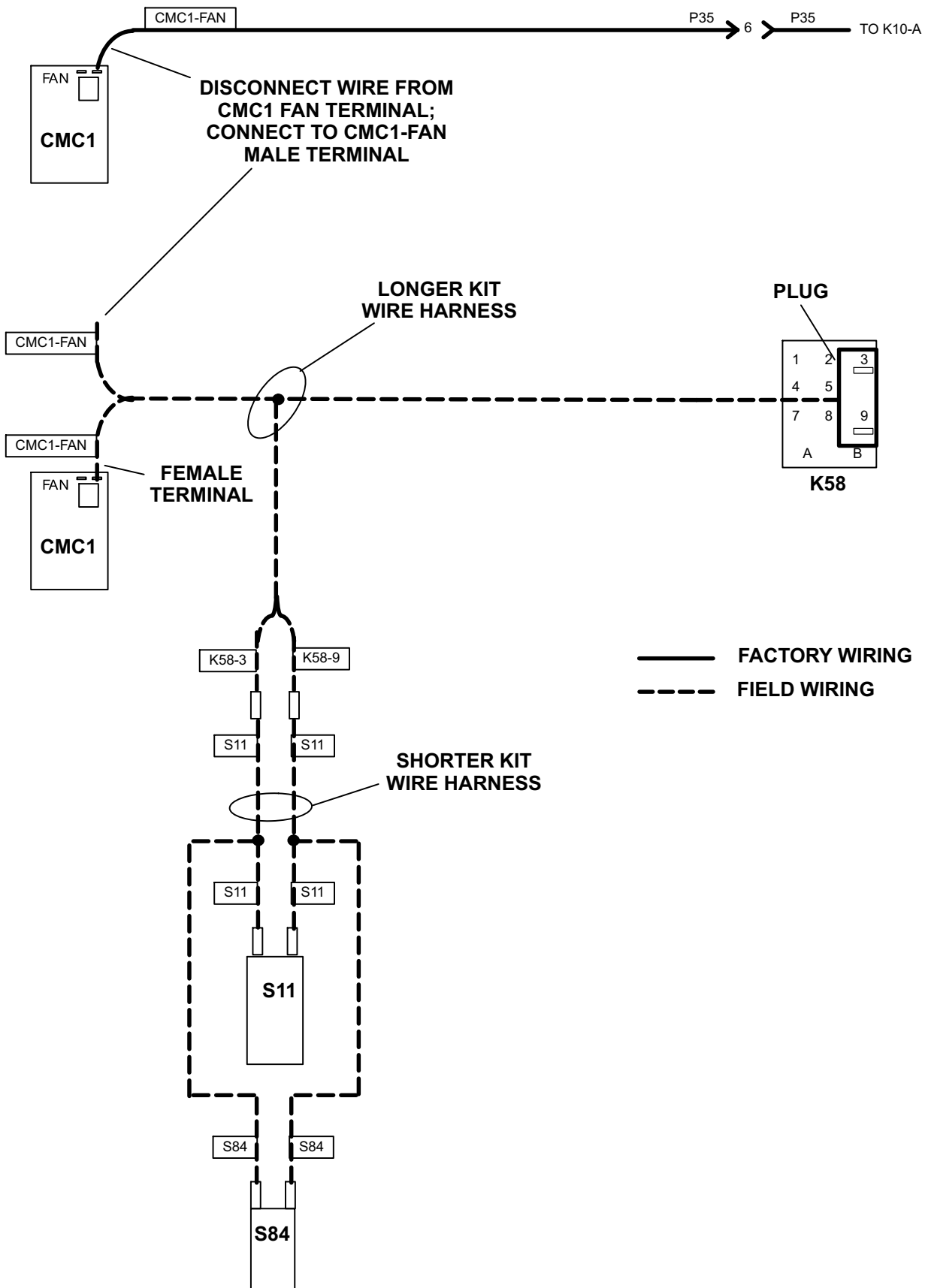
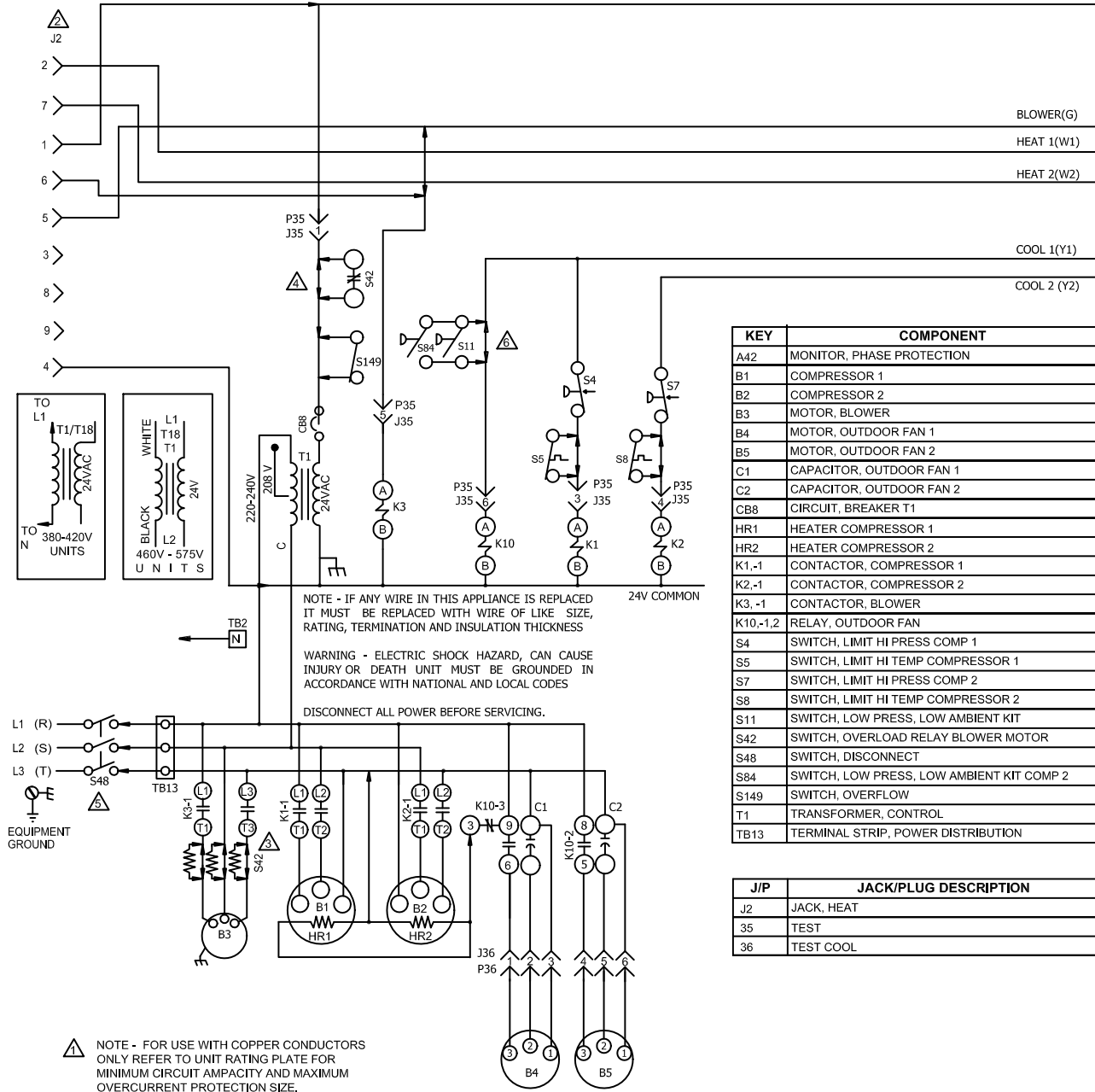

FIGURE 13

WIRING - ZG/ZC 092-150 UNITS

24V POWER



KEY	COMPONENT
A42	MONITOR, PHASE PROTECTION
B1	COMPRESSOR 1
B2	COMPRESSOR 2
B3	MOTOR, BLOWER
B4	MOTOR, OUTDOOR FAN 1
B5	MOTOR, OUTDOOR FAN 2
C1	CAPACITOR, OUTDOOR FAN 1
C2	CAPACITOR, OUTDOOR FAN 2
CB8	CIRCUIT, BREAKER T1
HR1	HEATER COMPRESSOR 1
HR2	HEATER COMPRESSOR 2
K1,-1	CONTACTOR, COMPRESSOR 1
K2,-1	CONTACTOR, COMPRESSOR 2
K3,-1	CONTACTOR, BLOWER
K10,-1,2	RELAY, OUTDOOR FAN
S4	SWITCH, LIMIT HI PRESS COMP 1
S5	SWITCH, LIMIT HI TEMP COMPRESSOR 1
S7	SWITCH, LIMIT HI PRESS COMP 2
S8	SWITCH, LIMIT HI TEMP COMPRESSOR 2
S11	SWITCH, LOW PRESS, LOW AMBIENT KIT
S42	SWITCH, OVERLOAD RELAY BLOWER MOTOR
S48	SWITCH, DISCONNECT
S84	SWITCH, LOW PRESS, LOW AMBIENT KIT COMP 2
S149	SWITCH, OVERFLOW
T1	TRANSFORMER, CONTROL
TB13	TERMINAL STRIP, POWER DISTRIBUTION

J/P	JACK/PLUG DESCRIPTION
J2	JACK, HEAT
35	TEST
36	TEST COOL

NOTE - IF ANY WIRE IN THIS APPLIANCE IS REPLACED IT MUST BE REPLACED WITH WIRE OF LIKE SIZE, RATING, TERMINATION AND INSULATION THICKNESS

WARNING - ELECTRIC SHOCK HAZARD, CAN CAUSE INJURY OR DEATH UNIT MUST BE GROUNDED IN ACCORDANCE WITH NATIONAL AND LOCAL CODES

DISCONNECT ALL POWER BEFORE SERVICING.

- ⚠ NOTE - FOR USE WITH COPPER CONDUCTORS ONLY REFER TO UNIT RATING PLATE FOR MINIMUM CIRCUIT AMPACITY AND MAXIMUM OVERCURRENT PROTECTION SIZE.
- ⚠ J2 IS USED ON ZGA UNITS OR FIELD INSTALLED ZCA WITH ELECTRICAL HEAT
- ⚠ IMPORTANT: TO PREVENT MOTOR BURNOUT, NEVER CONNECT MORE THAN ONE MOTOR LEAD TO ANY ONE CONNECTION. TAPE UNUSED MOTOR LEADS
- ⚠ S42 USED ON "M" VOLTAGE UNITS
- ⚠ S48 OR CB8 MAY BE USED
- ⚠ JUMPER WHEN S11 AND S84 ARE NOT USED

← DENOTES OPTIONAL COMPONENTS
 — LINE VOLTAGE FIELD INSTALLED

04/14	WIRING DIAGRAM	04/14
537671-01		
COOLING - CAV		
ZCA, ZGA - 092, 102, 120, 150 - G, J, M, Y		
SECTION B		REV. 0
Supersedes		New Form No. 537671-01

FIGURE 14

WIRING - ZH 092-150UNITS

24V POWER

BLOWER(G)

HEAT 1(W1)

HEAT 2(W2)

COOL 1(Y1)

COOL 2 (Y2)

24V COMMON

KEY	COMPONENT
B1	COMPRESSOR 1
B2	COMPRESSOR 2
B3	MOTOR, BLOWER
B4	MOTOR, OUTDOOR FAN 1
B5	MOTOR, OUTDOOR FAN 2
C1	CAPACITOR, OUTDOOR FAN 1
C2	CAPACITOR, OUTDOOR FAN 2
CMC1	TIMER, DEFROST
HR1	HEATER COMPRESSOR 1
HR2	HEATER COMPRESSOR 2
K1-1	CONTACTOR, COMPRESSOR 1
K2-1	CONTACTOR, COMPRESSOR 2

NOTE - IF ANY WIRE IN THIS APPLIANCE IS REPLACED IT MUST BE REPLACED WITH WIRE OF LIKE SIZE, RATING, TERMINATION AND INSULATION THICKNESS

WARNING - ELECTRIC SHOCK HAZARD, CAN CAUSE INJURY OR DEATH UNIT MUST BE GROUNDED IN ACCORDANCE WITH NATIONAL AND LOCAL CODES

DISCONNECT ALL POWER BEFORE SERVICING.

K3	CONTACTOR, BLOWER
K8-1,2,3	RELAY, DEFROST
K10-1,2,3	RELAY, OUTDOOR FAN
K58-1,2	RELAY, REVERSING VALVE
K132-1	RELAY, COMPRESSOR 1 ON
K133-1	RELAY, COMPRESSOR 2 ON
L1	VALVE, REVERSING 1
L2	VALVE, REVERSING 2
S4	SWITCH, LIMIT HI PRESS COMP 1
S5	SWITCH, LIMIT HI TEMP COMP 1
S6	SWITCH, DEFROST COMP 1
S7	SWITCH, LIMIT HI PRESS COMP 2
S8	SWITCH, LIMIT HI TEMP COMP 2
S9	SWITCH, DEFROST COMPRESSOR 2
S11	SWITCH, LOW PRESS, LOW AMBIENT KIT
S84	SWITCH, LOW PRESS, LOW AMBIENT KIT, COMP 2
S104	SWITCH, DEFROST PRESS, COMP 2
T1	TRANSFORMER, CONTROL
T18	TRANSFORMER
TB2	TERMINAL STRIP UNIT
TB13	TERMINAL STRIP, POWER DISTRIBUTION

J/P	JACK/PLUG DESCRIPTION
2	HEAT
35	TEST HEAT
36	TEST COOL

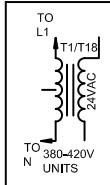
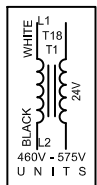

▲ NOTE - FOR USE WITH COPPER CONDUCTORS ONLY REFER TO UNIT RATING PLATE FOR MINIMUM CIRCUIT AMPACITY AND MAXIMUM OVERCURRENT PROTECTION SIZE.

▲ TB2 IS USED ON "M" VOLTAGE UNITS ONLY

▲ IMPORTANT: TO PREVENT MOTOR BURNOUT, NEVER CONNECT MORE THAN ONE MOTOR LEAD TO ANY ONE CONNECTION. TAPE UNUSED MOTOR LEADS

← DENOTES OPTIONAL COMPONENTS
 — LINE VOLTAGE FIELD INSTALLED

08/14		WIRING DIAGRAM	08/14
	537672-01		
HEAT PUMP - CAV			
ZHA - 092, 102, 120 - G, J, M, Y			
SECTION B			REV. 0
Supersedes		New Form No. 537672-01	

FIGURE 15