



ENERGENCE KITS AND ACCESSORIES

R11A-50LDW

July 12, 2010
Supersedes 02-12-10

50R1150xH ENERGY RECOVERY SYSTEM

INSTALLATION INSTRUCTIONS FOR ENERGY RECOVERY SYSTEMS (ERS) USED WITH ENERGENCE 072 SERIES UNITS



Patent# 5,548,970

ETL Certified
per UL 1995
and CSA 22.2

! WARNING

Improper installation, adjustment, alteration, service or maintenance can cause property damage, personal injury or loss of life. Installation and service must be performed by a qualified installer or service agency.

SHIPPING AND PACKING LIST

Package 1 of 1 contains: **See Illustration 1 and 2.**

- 1 - Energy Recovery System Assembly
- 1 - Outdoor Fresh Air Hood with Filter
- 1 - Outdoor Exhaust Air Hood with Barometric Damper
- 1 - Top Filler Panel
- 1 - Bottom Filler Panel w/ Platform Support Rail (Mounted)
- 2 - Side Filler (Installed on ERS)
- 1 - Balancing Damper Assembly
- 1 - Hardware Bag:
 - 14' - Gasket $\frac{3}{4}$ " x $1\frac{1}{4}$ "
 - 7' - Gasket $\frac{1}{8}$ " x $\frac{1}{2}$ "
 - 1 - Field Harness
 - 4 - Wire Ties
 - 10 - Self-Tapping Screws 10-16 x $\frac{1}{2}$ "
 - 8 - Gold Screws 10-16 x $\frac{1}{2}$ "
 - 1 - Installation Instruction

PRINCIPLE OF OPERATION

The ERS enthalpy wheel contains parallel layers of a polymeric material that are impregnated with silica gel (desiccant). The wheel is located in the entering (intake) air and exhaust air streams of the ventilation equipment. As the wheel rotates through each air stream, the wheel surface adsorbs sensible and latent energy. In the heating mode, the wheel rotates to provide a constant transfer of heat from the exhaust air stream to the colder intake air stream. During the cooling season, the process is reversed.

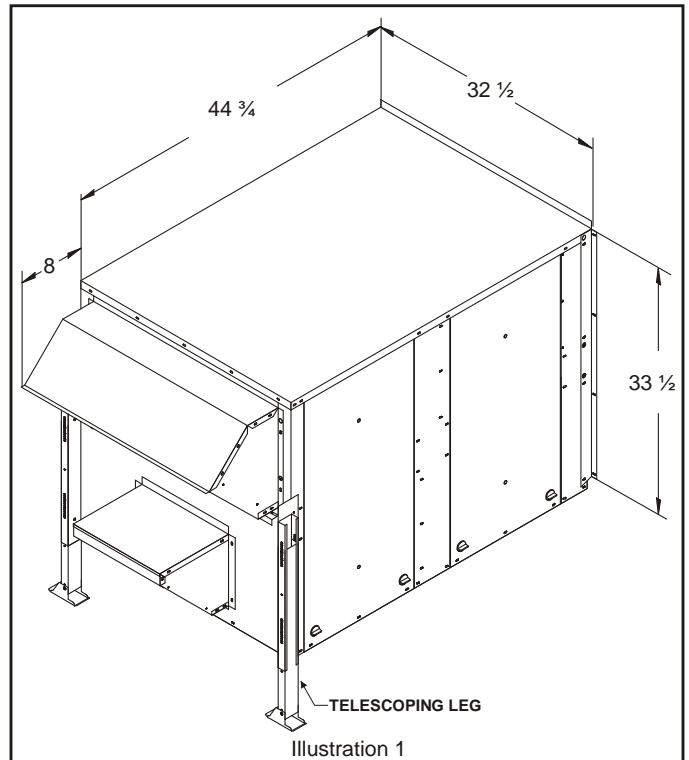

Illustration 1

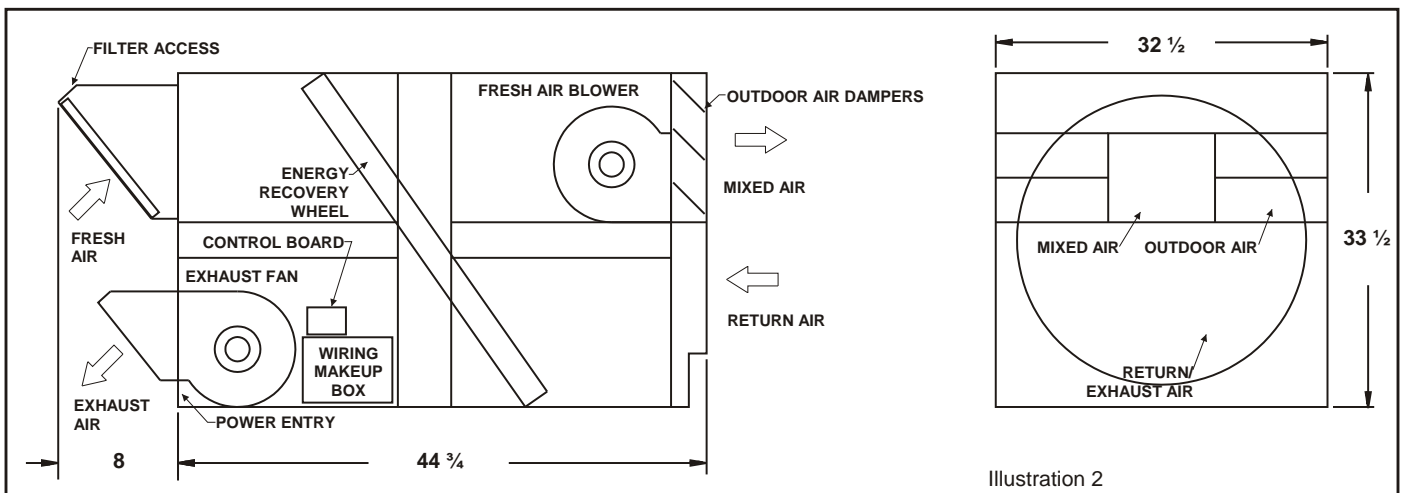

Illustration 2

CAUTION



Electric shock hazard. Can cause injury or death. Before attempting to perform any service or maintenance, turn the electrical power to unit OFF at disconnect switch(es). Unit may have multiple power supplies.

GENERAL

These instructions are intended as a general guide and do not supersede local codes in any way. Authorities having jurisdiction should be consulted before installation.

REQUIREMENTS

When installed, the unit must be electrically wired and grounded in accordance with local codes or, in the absence of local codes, with the current National Electric Code, ANSI/NFPA No. 70.

SHIPPING DAMAGE

Check unit for shipping damage. Receiving party should contact last carrier immediately if shipping damage is found.

RIGGING UNIT FOR LIFTING

1. Maximum weight of unit is — 300 Lbs (crated).
2. Remove crating and retrieve hardware bag that is inside of ERS.
3. All ERS door panels must be in place for rigging.
4. Use straps to lift unit.

ROOFTOP UNIT PREPARATION

1. Disconnect all power to rooftop unit.
2. Open filter access door.
3. Remove the rooftop unit horizontal return air access panels. Also remove any hoods and/or power exhaust equipment. Discard hoods, power exhaust equipment, and horizontal return air panels. **See Figure 1.**

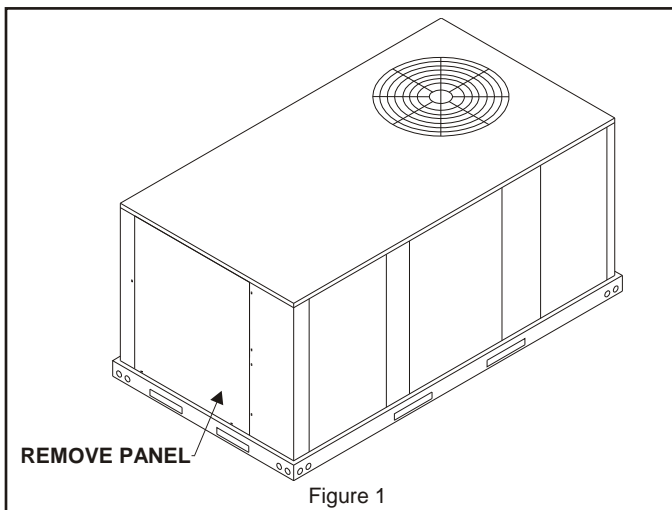

4. If a factory install ERS Harness (J298/P153) is installed go to **Step 5**, otherwise use the provided harness from the hardware bag within the ERS and complete the following steps.

- A. Locate the field harness from the hardware bag shipped inside the ERS.
- B. With door panels open on the control side of RTU, route the wire harness bare ends (3 wires Green, Pink and Black) from return section along the RTU wire at the top of unit and through panel above the filter rack. **See Figure 2.**



- C. Follow wires all the way through blower section. **See Figure 3.**

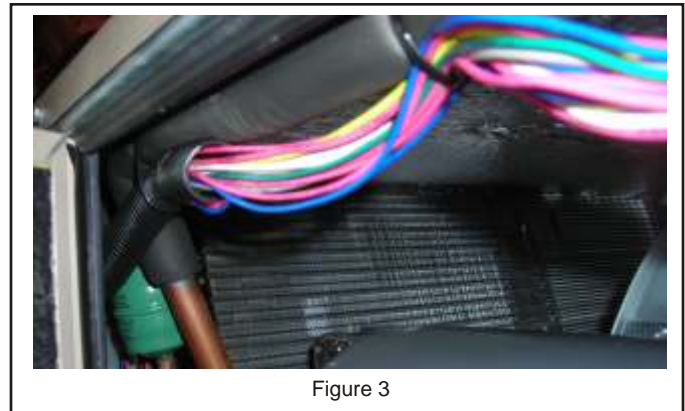

- D. Continue to follow wires along the top and through divider panel into the control center. **See Figure 4.**

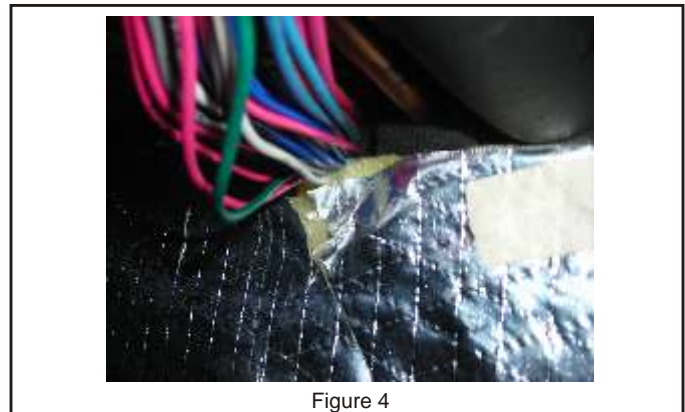

- E. Route wire through the control section down to the IMC2 control board. Strip the wire ends 3/8" if they have not been pre-done. Place the Green wire under screw terminal at J298-8 (Purple connector). Do the same routine for Pink at J298-10 and Black to J298-9. **See Figure 5.**

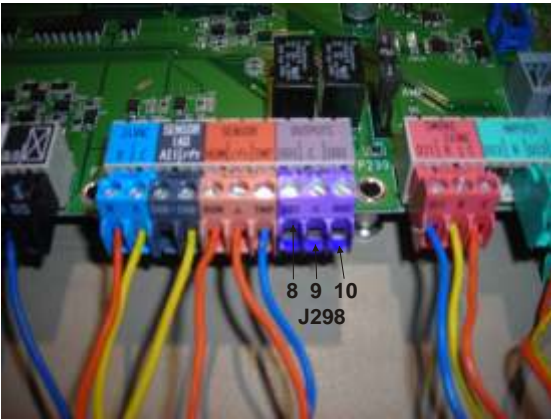

Figure 5

5. Slide in balancing damper over return duct opening. Put balancing damper in place with the damper blade at the bottom. **See Figure 6.** Loosen wing nut on adjustable quadrant, rotate arm to set blades to 50% open and retighten wing nut. **See Figure 7.**



Figure 6



Figure 7

6. Route the 3-pin connector P153 and wiring harness under the balancing damper and out the return air. Coil excess wire and route into return air of the rooftop unit. **See Figure 8.**



Figure 8

7. Using wire ties neatly route the wires to clear any moving parts.

INSTALL ENERGY RECOVERY SYSTEM

1. Apply 3/4" x 1 1/4" gasket to top and bottom decks of ERS as shown in the figure. **See Figure 9.**

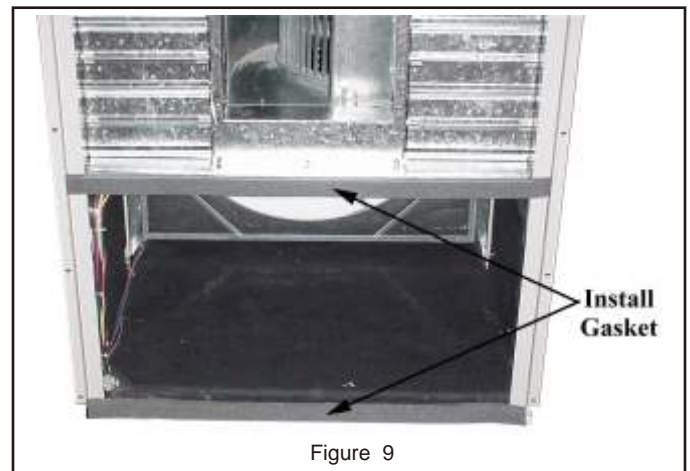

Figure 9

2. Attach bottom filler panel with platform support rail to bottom opening of rooftop unit aligning with screw holes used by removed door panel. Secure in place as shown in **Figure 10.**

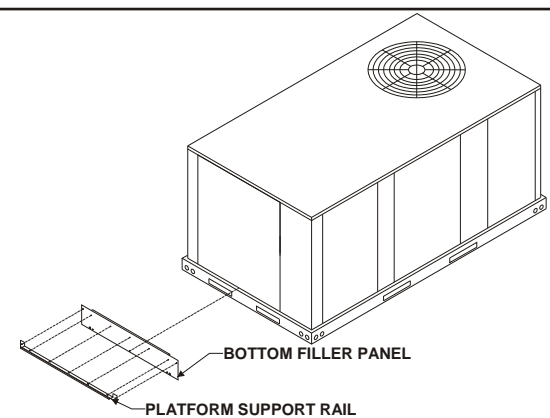

Figure 10

3. Remove all screws holding the top panel of rooftop unit around the horizontal exhaust air opening. Ensure that the top panel will move upward at least 2".

4. Lift ERS at least three feet (3'). Remove four screws holding telescoping leg to guide and pull out leg. Reinsert the leg from the bottom with the flat foot under the unit and reinsert one of the screws to hold leg into place. The leg will need to be adjusted later when unit is in position.
5. Position ERS in front of horizontal exhaust air opening. Line up the ERS to the rooftop unit. Ensure that there are not any screws on the rooftop unit that will interfere with the mounting flanges of the ERS and if so remove them.

Note: Equipment support kit or equivalent should be used under feet of standoff legs to prevent roof penetration. See Figure 11.

6. Lift ERS front end into the platform support rail catching the base pan of ERS.
7. Remove the screws placed in the telescoping legs and adjust the legs on the ERS until it is level. Replace all four screws in each leg to secure the ERS in the leveled position. **See Figure 11.**



Figure 11

8. Insert top filler panel under the rooftop unit top panel with 1" flange pointing out away from unit and on top of ERS top panel to provide a rain seal. **See Figure 12.**
9. Use provided 10-16 x 1/2" self-tapping screws to secure the of the ERS to the rooftop unit. **See Figure 12.**

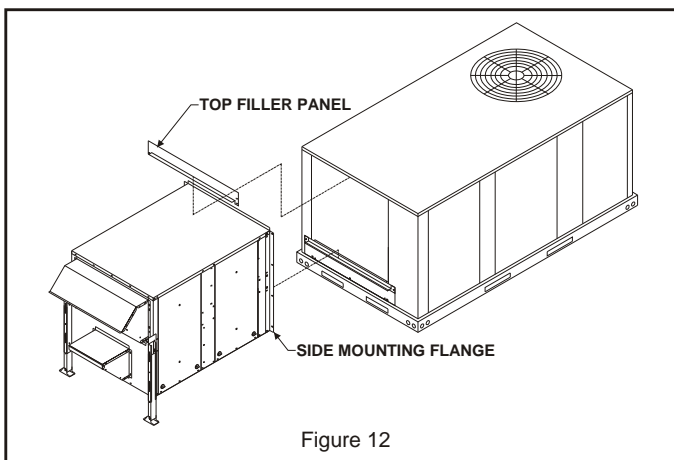

Figure 12

10. Check and seal, if necessary, along the edges where the ERS meets the rooftop unit to ensure there is no air leakage. Final assembly should resemble **Figure 13.**

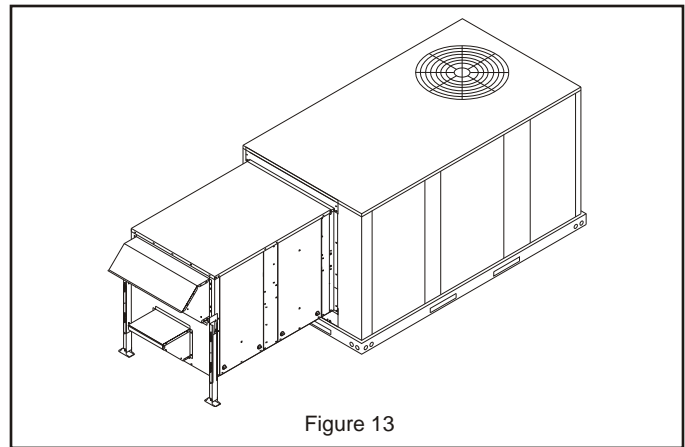

Figure 13

11. Remove the right front (rooftop unit side) access panel and locate the field wiring harness that was previously routed into the return air of the rooftop unit. Plug the field wiring harness into the connector located at the bottom of the access door inside the ERS. **See Figure 14 and Figure 15.**

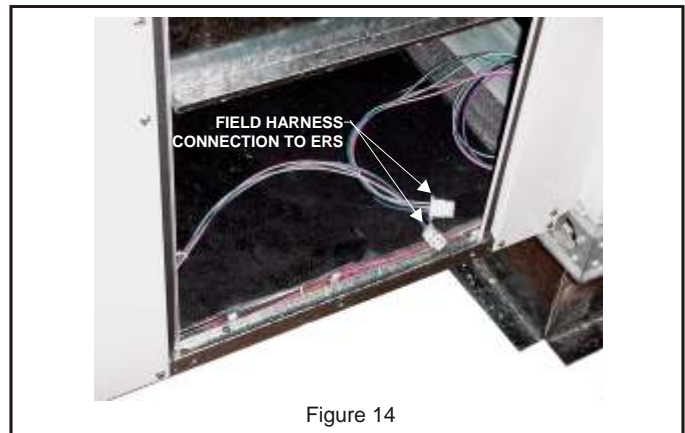

Figure 14

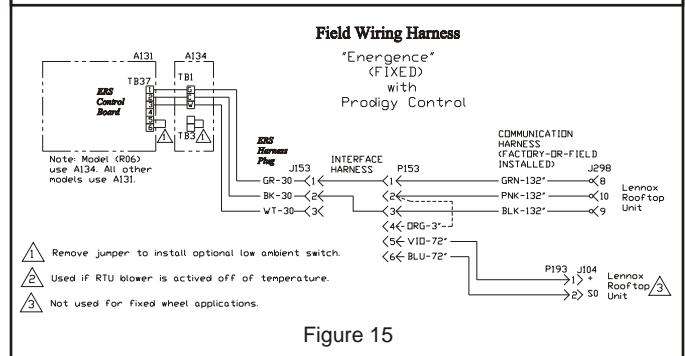

Figure 15

12. All electrical connections must conform to any local codes and the current National Electric Codes (NEC) and Canadian Electric Code (CEC). Refer closely to wiring diagram in unit and/or in these instructions for proper connections. Refer to the unit nameplate for the minimum circuit ampacity and maximum over current protection size. Electrical data is listed on unit rating plate and motor nameplates.

13. Connect line voltage power to ERS unit from ERS field provided or rooftop unit disconnect switch (disconnect must be properly sized). Then connect line voltage from disconnect switch through ERS knockout on middle post to control box per the wiring diagram. **See Figure 16 and 17.**



Figure 16

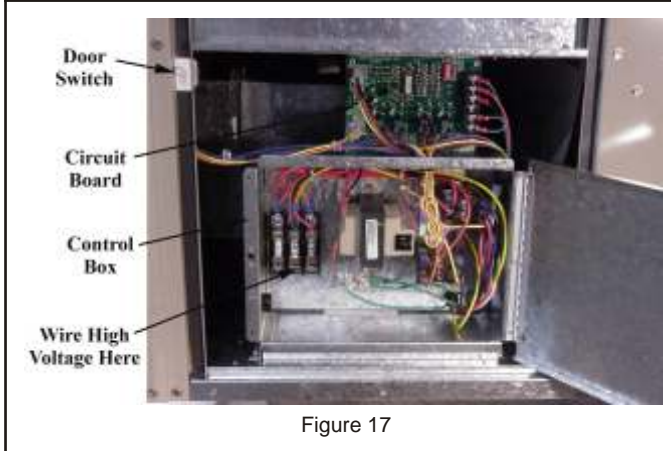

Figure 17

14. Ground unit with a suitable ground connection either through unit supply wiring or earth ground.

Note: Unit voltage entries must be sealed weather tight after wiring is complete.

15. Replace access panels onto the ERS unit and secure.

**ROOFTOP UNIT WIRING
(See Field Wiring Diagram)**

1. Open access panel to rooftop unit controls.
2. The minimum damper blade position must be adjusted on the IMC2 control board to the correct amount of outside air specified by the customer. Refer to Lennox rooftop unit manual for setting.

Wheel Adjustment

The Electronic Configuration To Order (ECTO) parameter must be set at ECTO 7.22 = 10 to indicate ERS is installed.

During default operation the ERS will start when the RTU unit blower is on.

The A55 (IMC2) uses the following parameters to control ERS. See Figure 18.

For Smoke Mode reference the Smoke Mode Operation table. Only positive pressure option is available.

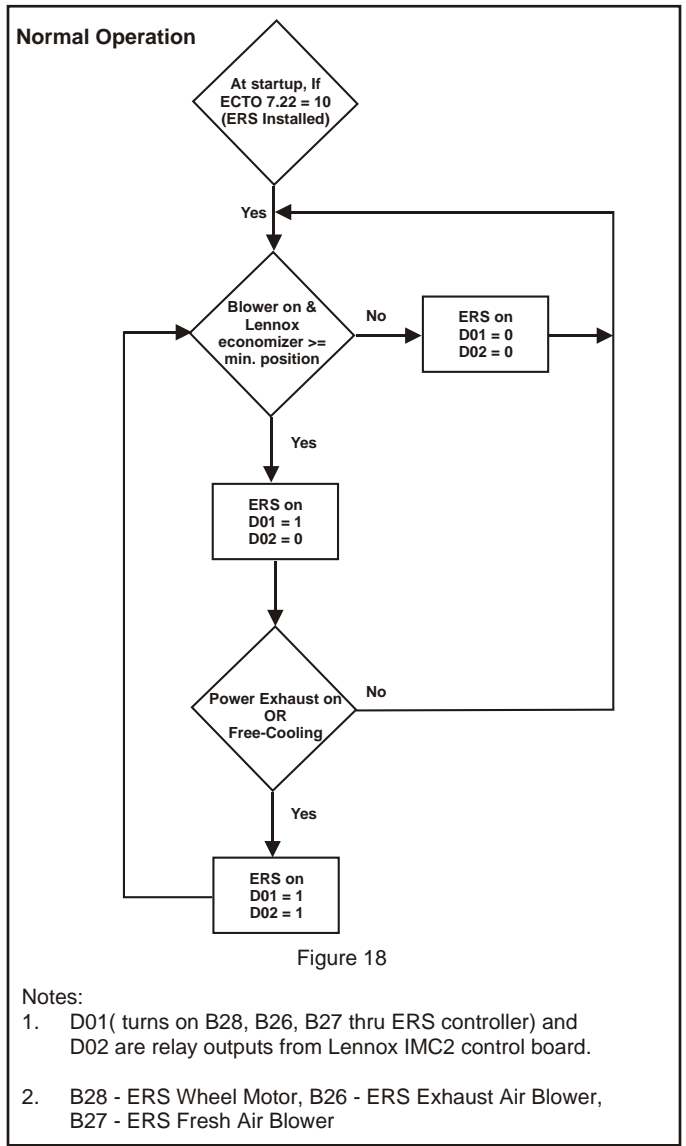

Smoke Mode Operation

Smoke Mode Setting (ECTO 5.01)	Blower	D02	Damper	D01
0, unit off (default)	OFF	OFF	Closed	OFF
1, pos. pressure	ON	OFF	100% Open	ON

3. Close access panels on the rooftop unit and secure.
4. Restore power to unit.
5. Once ERS is working properly, caulk any open joints, holes, or seams to make the units completely air and water tight.
6. Leave this instruction manual with owner or in an envelope to be kept near unit.

OPTIONAL KITS (Factory Installed)

Motorized Intake Air Damper

Damper mounts behind the outdoor air intake hood. It opens when the ERS is energized and closes when de-energized. Powered by B30 damper motor.

Pressure Sensor

Measurement device on the ERS to determine airflow across the Enthalpy Wheel.

Low Ambient Control Kit (S26)

Prevents frost formation on energy wheel heat transfer surfaces by terminating the intake blower operation when discharge air temperature falls below a field selectable temperature setting. Intake blower operation resumes after temperature rises above the adjustable temperature differential.

The frost threshold is the outdoor temperature at which frost will begin to form on the ERS wheel. For energy recovery systems, the frost threshold is typically below 10°F. Frost threshold is dependent on indoor temperature and humidity. The table shows how the frost threshold temperatures vary depending on indoor conditions.

FROST THRESHOLD TEMPERATURE	
INDOOR RH AT 70°F	FROST THRESHOLD TEMPERATURE
20%	0°F
30%	5°F
40%	10°F

Because Energy Recovery Systems have a low frost threshold, frost control options are not necessary in many climates. Where outdoor temperatures may drop below the frost threshold during the ERS operational hours, exhaust only frost control option is available.

Stop-Start-Jog

Control option that allows intermittent operation of the enthalpy wheel during mild outdoor conditions to provide cycling and cleaning of the wheel.

BLOWER SPEED ADJUSTMENT

Blower speed selection is accomplished by changing the speed tap wire (refer to wiring diagram) on both fresh air and exhaust air blowers. All blowers are factory set at "high" for maximum airflow. To determine air flow setting, external static pressure readings will need to be read across the ERS. **Reference Table 1 on page 8.** For location to take pressure readings. **See Figure 19.**

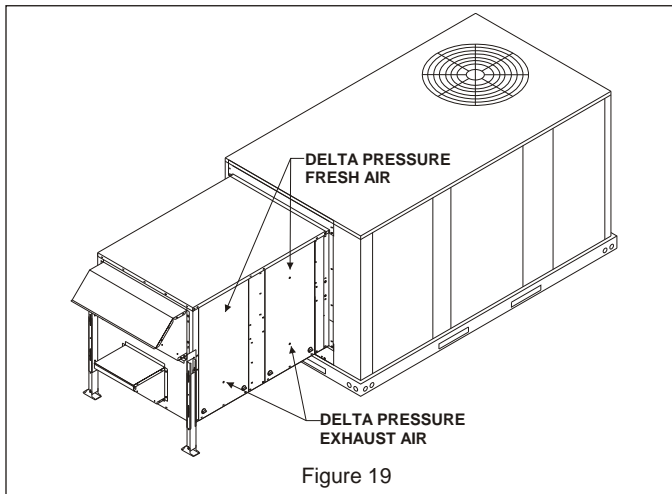

Figure 19

OPERATION

Recovery Wheel Mode

On a thermostat call for blower operation in heating, cooling or continuous blower, the ERS media will rotate between fresh air and exhaust air streams. Both the fresh air blower and exhaust air blower will be operating.

SYSTEM CHECK

1. Disconnect ERS main power.

Note: If Low ambient kit S26 is used the jumper between TB37-5 and TB37-6 should be removed. Also if system check out is being conducted at low ambient temperatures, jumper low ambient switch.

2. Open rooftop unit blower access panel and locate TB1. Jumper terminals 6 (24v) and 3 (G) to energize rooftop unit blower. Refer to manufacturers instructions when an electronic thermostat or other energy management system is used.
3. Disconnect main power to unit before making adjustment to balancing damper and/or ERS unit.
4. Remove all jumpers and replace ERS control access cover.
5. Set thermostat to normal operating position.
6. Restore power to unit.

MAINTENANCE

Motor Maintenance

All motors use prelubricated sealed bearings; no further lubrication is necessary.

Mechanical Inspection

Make visual inspection of dampers, linkage assemblies and ERS rotating bearings during routine maintenance. Filters should be checked periodically and cleaned when necessary. Filter is located in fresh air hoods. **DO NOT** replace permanent filters with throwaway type filters.

Energy Wheel Maintenance

Four pie-shaped energy recovery wheel segments are seated on stops between the stainless steel spring retainers, secured to the hub and rim of wheel. Annual inspection of the self cleaning wheel is recommended. With power disconnected, remove ERS access panels (rear) and unplug (J150 & P150). Refer to wiring diagram in this instruction manual. Each segment is secured in place by a stainless steel spring retainer located on wheel rim. Remove one end of the stainless steel spring retainer from the slot in the wheel rim and remove. Do the same on the next retainer. Remove segment and wash with water and/or mild detergent. Replace segment by reversing the above procedure. **See Figure 20.** Discoloration and staining of ERS segment does not affect its performance. Only excessive buildup of foreign material need be removed. If the segment appears excessively dirty, it should be cleaned to ensure maximum operating efficiency. Thoroughly spray plastic surface with household cleaner such as Fantastic or equivalent middle detergent and gently rinse with warm water using a soft brush to remove heavier accumulation. Shake excess water from segment and replace in reverse of removal instructions.

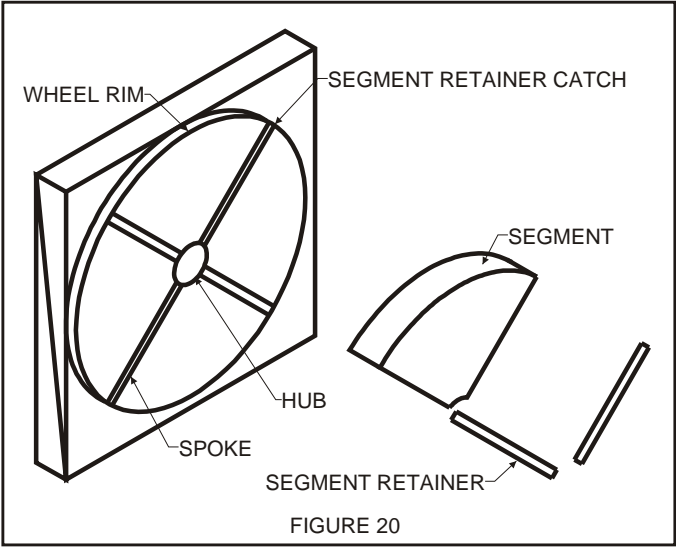

50R1150xH* Series

ENERGY RECOVERY SYSTEMS

ERS
 BlowHi
 BlowMed
 BlowLo

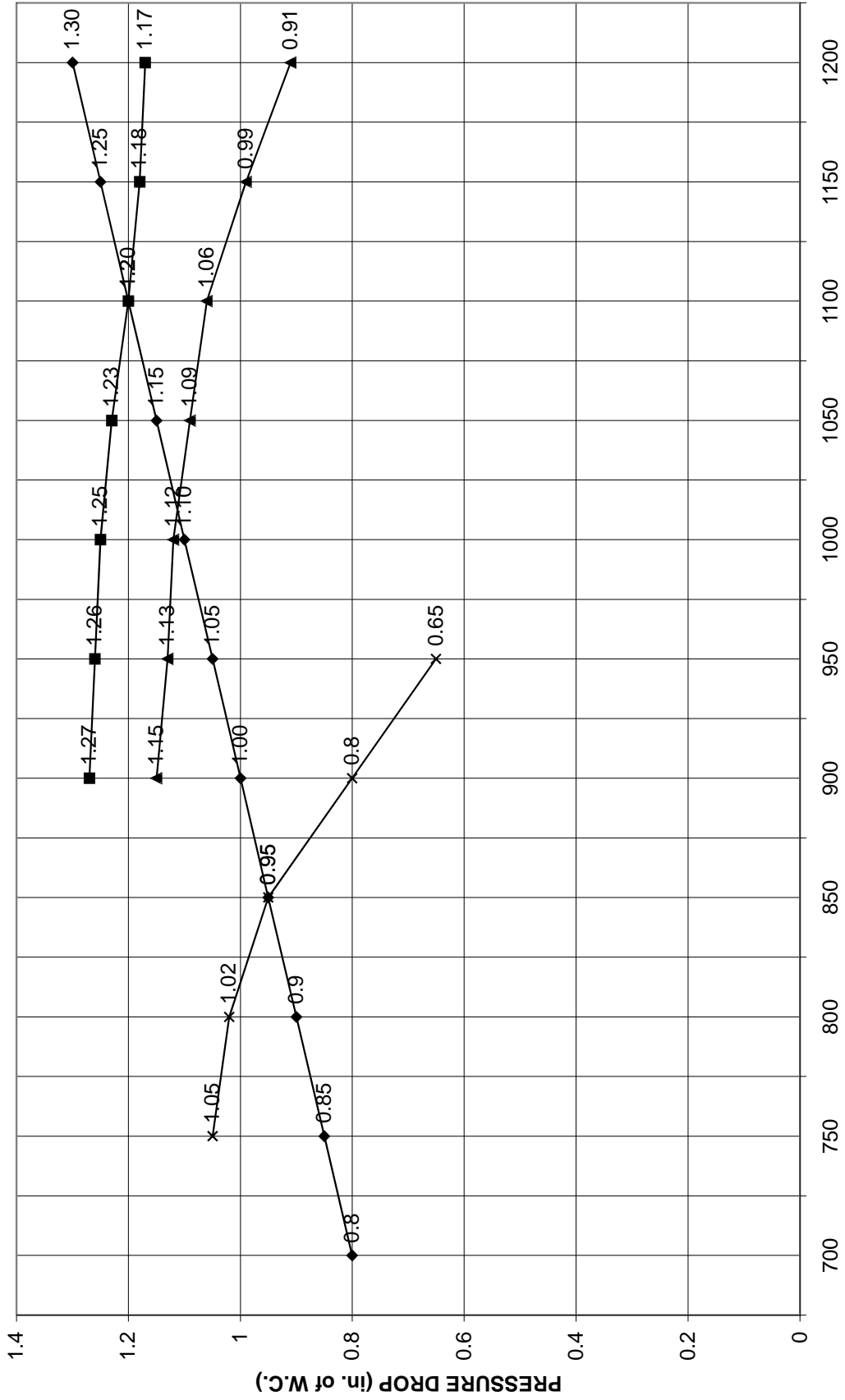

Equation of Line: $SCFM = (PD - 0.0568182) / 0.0010455$
 TABLE#1

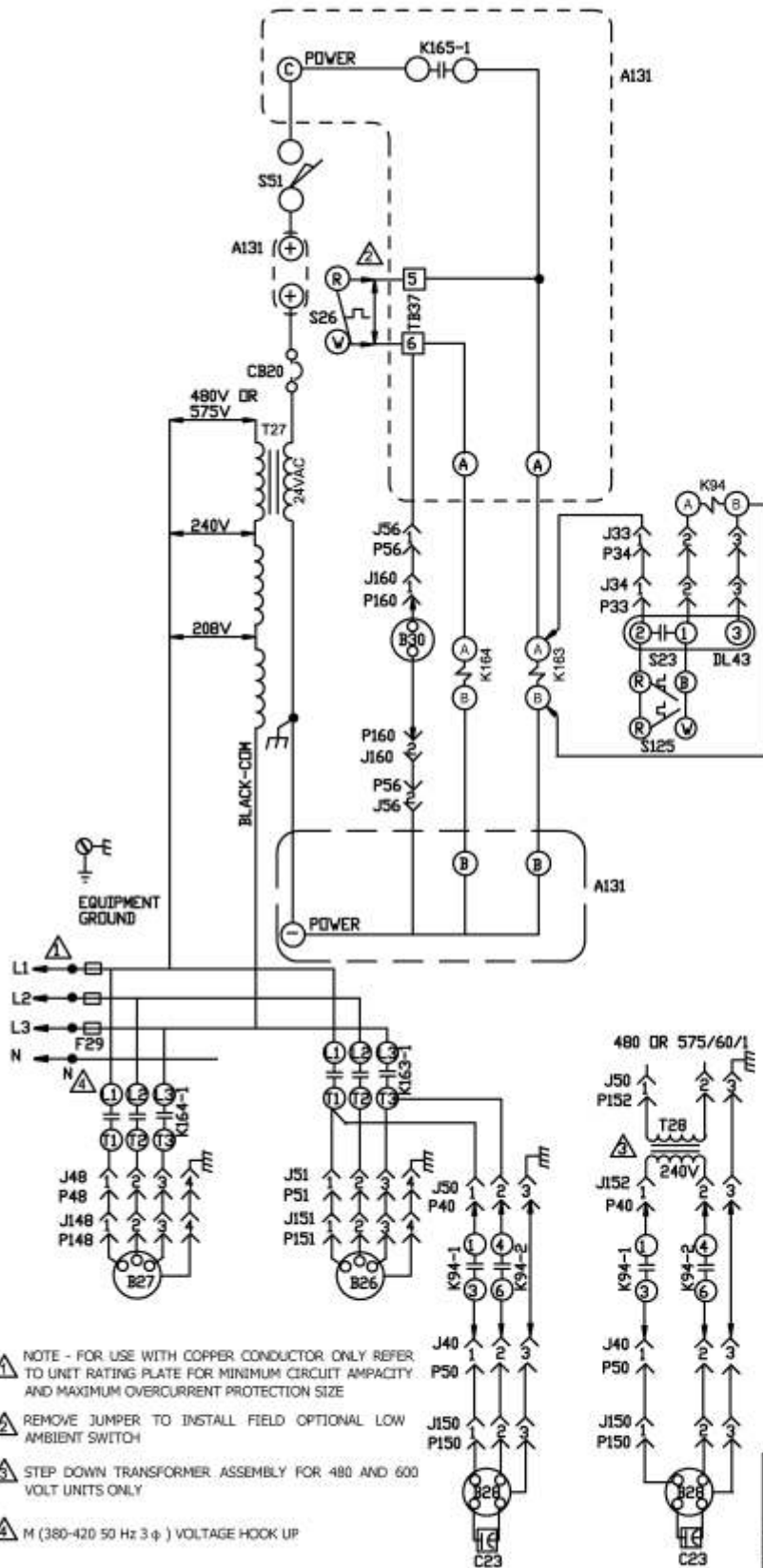

KEY	DESCRIPTION
A131	CONTROL, FIXED WHEEL
B26	MOTOR, EXHAUST AIR BLOWER
B27	MOTOR, FRESH AIR BLOWER
B28	MOTOR, DESSICAN WHEEL
B30	MOTOR, DAMPER (OPTIONAL)
C23	CAPACITOR, WHEEL MOTOR
CB20	CIRCUIT BREAKER, DESSICAN WHEEL
DL43	DELAY, CYCLE CONTROL
F29	FUSE, DESSICANT WHEEL
J33	JACK, CYCLE CONTROL
J34	JACK, CYCLE CONTROL HARNESS
J40	JACK, WHEEL CYCLE
J48	JACK, MOTOR VARIABLE SPEED
J50	JACK, TRANSFORMER
J51	JACK, EXHAUST BLOWER
J56	JACK, DAMPER MOTOR PCB
J148	JACK, FRESH AIR BLOWER
J150	JACK, WHEEL MOTOR
J151	JACK, EXHAUST BLOWR MOTOR
J152	JACK, TRANSFORMER EXHAUST BLOWER
J160	JACK, DAMPER MOTOR
K94, -1,2	RELAY, ON - OFF
K163, -1	CONTACTOR, EXHAUST AIR BLOWER
K164, -1	CONTACTOR, FRESH AIR BLOWER
P33	PLUG, CYCLE CONTROL
P34	PLUG, CYCLE CONTROL HARNESS
P40	PLUG, WHEEL CYCLE
P48	PLUG, MOTOR VARIABLE SPEED
P50	PLUG, TRANSFORMER
P51	PLUG, EXHAUST BLOWER
P56	PLUG, DAMPER MOTOR (OPTIONAL)
P148	PLUG, FRESH AIR BLOWER
P150	PLUG, WHEEL MOTOR
P151	PLUG, EXHAUST BLOWER MOTOR
P152	PLUG, TRANSFORMER EXHAUST BLOWER
P160	PLUG, DAMPER MOTOR
S23	SWITCH, LOW AMBIENT CUT IN
S26	THERMOSTAT, AMBIENT
S51	SWITCH, DOOR INTERLOCK
S125	SWITCH, AMBIENT OVERRIDE
T27	TRANSFORMER, DESSICANT WHEEL
T28	TRANSFORMER, STEP DOWN WHEEL MOTOR

NOTE - IF ANY WIRE IN THIS APPLIANCE IS REPLACED IT MUST BE REPLACED WITH WIRE OF LIKE SIZE, RATING, TERMINATION AND INSULATION THICKNESS

WARNING - ELECTRIC SHOCK HAZARD, CAN CAUSE INJURY OR DEATH. UNIT MUST BE GROUNDED IN ACCORDANCE WITH NATIONAL AND LOCAL CODES DISCONNECT ALL POWER BEFORE SERVICING.

← DENOTES OPTIONAL COMPONENTS
 — LINE VOLTAGE FIELD INSTALLED NEC/CEC CLASS I

- ⚠ NOTE - FOR USE WITH COPPER CONDUCTOR ONLY REFER TO UNIT RATING PLATE FOR MINIMUM CIRCUIT AMPACITY AND MAXIMUM OVERCURRENT PROTECTION SIZE
- ⚠ REMOVE JUMPER TO INSTALL FIELD OPTIONAL LOW AMBIENT SWITCH
- ⚠ STEP DOWN TRANSFORMER ASSEMBLY FOR 480 AND 600 VOLT UNITS ONLY
- ⚠ M (380-420 50 Hz 3 φ) VOLTAGE HOOK UP

WIRING DIAGRAM		02/10
ACCESSORIES		
FIXED ENERGY RECOVERY WHEEL FOR ENERGENCE AND LANDMARK - G, J, M, Y		
SECTION F		REV. 1.0
Supersedes	New Form No. 537330-01	

© 2009

Lennox Commercial

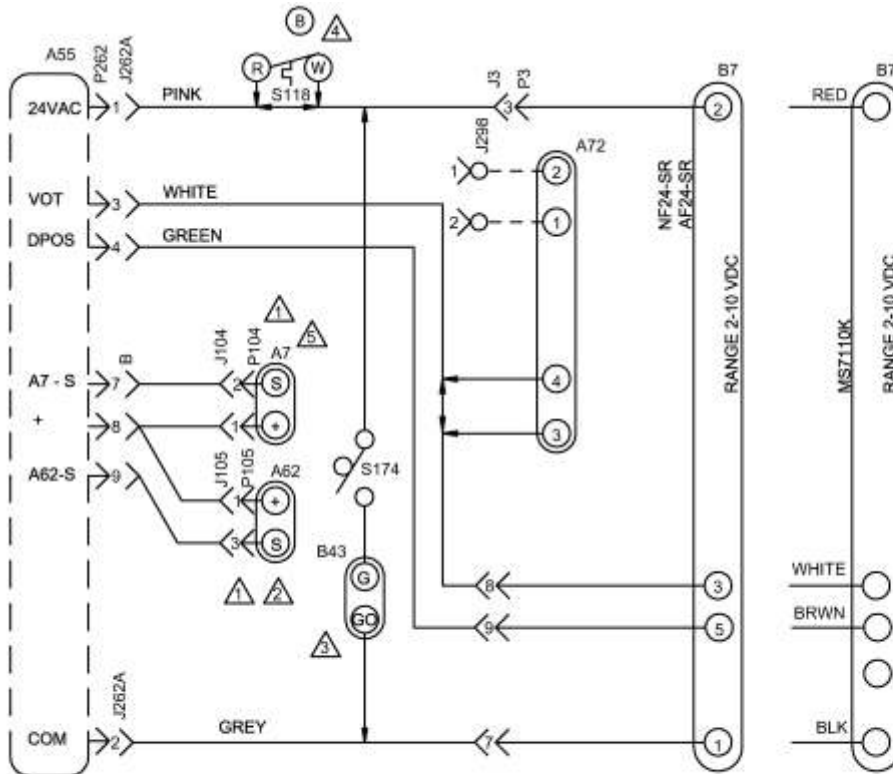

KEY	DESCRIPTION
A7	SENSOR, SOLID STATE ENTHALPY
A130	CONTROL, ERS
A55	CONTROL, MAIN PANEL LENNOX
A62	SENSOR, ENTHALPY INDOOR
A72	CONTROL, REMOTE MIN POS (OPT)
B7	MOTOR, DAMPER ECONOMIZER
B43	MOTOR, EXHAUST DAMPER
J3	JACK, UNIT ECONOMIZER
J104	JACK, SENSOR OUTDOOR ENTHALPY
J105	JACK, SENSOR RETURN AIR ENTHALPY
J153	JACK, ENTHALPY / DAMPER MOTOR
J193	JACK, ENTHALPY SENSOR
J288A	JACK, IAQ INTERFACE
J262A	JACK, DAMPER MOTOR
J262B	JACK, ENTHALPY SENSORS
P3	PLUG, ECONOMIZER BYPASS
P153	PLUG, ENTHALPY / DAMPER MOTOR
P193	PLUG, ENTHALPY SENSOR
P262	PLUG, ECONOMIZER OUTPUT
S118	THERMOSTAT, DESICANT DEFROST
S174	SWITCH, EXHAUST DAMPER

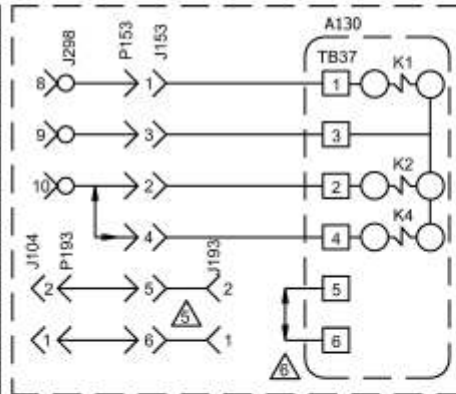

ENERGY RECOVERY WHEEL HOOK UP

- ⚠️ DELETE A7 AND A62 (IF USED) FOR EITHER GLOBAL ENTHALPY OR SENSIBLE TEMPERATURE CONTROL
- ⚠️ FOR UNIT DIFFERENTIAL ENTHALPY CONTROL, ADD A62 RETURN AIR ENTHALPY SENSOR
- ⚠️ OPTIONAL EXHAUST DAMPER ACTUATOR TO HOLD EXHAUST DAMPER CLOSED WHEN OUTSIDE AIR DAMPER IS CLOSED
- ⚠️ S118 USED ON 35 TO 50 TON ENERGENCE UNITS WITH ENERGY RECOVERY WHEEL (ERW)
- ⚠️ REPOSITION A7 ENTHALPY SENSOR FROM ROOFTOP UNIT ECONOMIZER INTO INTAKE HOOD OF THE ERW ROOFTOP UNIT
- ⚠️ REMOVE JUMPER WHEN INSTALLING OPTIONAL LOW AMBIENT SWITCH

NOTE- THIS DIAGRAM USED ONLY WHEN ECONOMIZER OR MOTORIZED OUTDOOR AIR DAMPERS ARE INSTALLED.

————— DESIGNATES OPTIONAL WIRING
 - - - - - CLASS II FIELD WIRING

WIRING DIAGRAM		09/09
ACCESSORIES		
ENERGENCE SERIES ECONOMIZER AND MOTORIZED OAD PIVOTING WHEEL ENERGY RECOVERY SYSTEM OPTION		
SECTION D		
Supersedes	New Form No.	
	537189-01	
© 2009	Lennox Commercial	

Lennox Model No.	Req'd Curb Height	CFM Range	Voltage	Phase
50R1150xH21	14"	700-1000	208-230	1
50R1150xH23	14"	700-1000	208-230	3
50R1150xH33	14"	700-1000	460	3
50R1150xH43	14"	700-1000	575	3

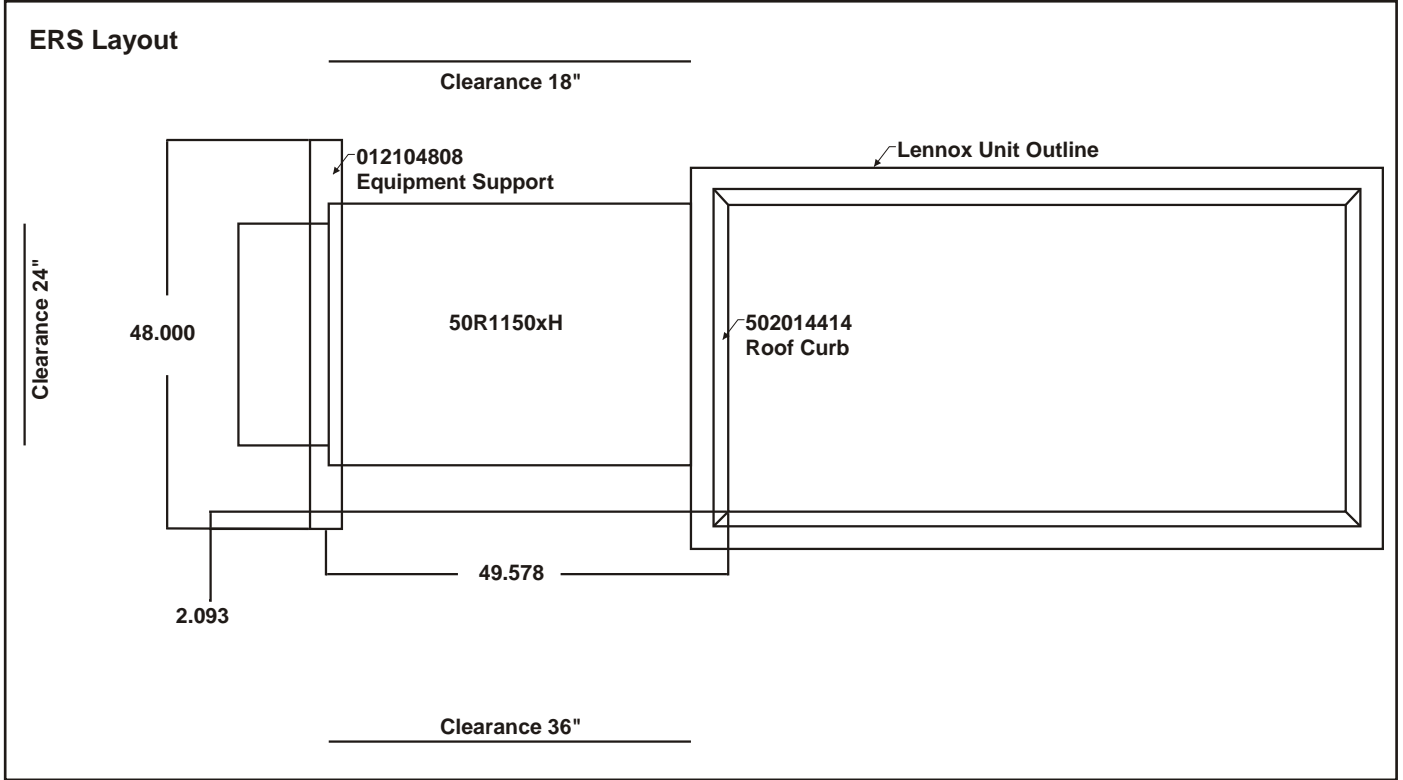

START UP INFORMATION SHEET

VOLTAGE - ERS UNIT

Incoming Voltage L1-L2 _____ L1-L3 _____ L2-L3 _____
Running Voltage L1-L2 _____ L 1-L3 _____ L2-L3 _____
Secondary Voltage _____ C (black) to G (green) Volts* _____
C (black) to W (white) Volts* _____

* With thermostat calling.

AMPERAGE - ERS MOTORS

Intake Motor: Nominal HP _____ Rated Amps _____ Running Amps _____
Exhaust Motor: Nominal HP _____ Rated Amps _____ Running Amps _____
Wheel Motor: Nominal HP _____ Rated Amps _____ Running Amps _____

AIRFLOW

Intake Design CFM _____ Pressure Drop _____ Calculated CFM _____
Exhaust Design CFM _____ Pressure Drop _____ Calculated CFM _____
Amb. db Temp _____ Return Air db Temp* _____ Tempered Air db Temp* _____
Amb. wb Temp _____ Return Air wb Temp* _____ Tempered Air wb Temp* _____

* Measure after 15 minutes of run time

INSTALLATION CHECK LIST

Model # _____ Serial # _____
Owner _____ Owner Phone # _____
Owner Address _____
Installing Contractor _____ Start Up Mechanic _____

- Inspect the unit for transit damage and report any damage on the carrier's freight bill.
- Check model number to insure it matches the job requirements.
- Install field accessories and unit adapter panels as required. Follow accessory and unit installation manuals.
- Verify field wiring, including the wiring to any accessories.
- Check all multi-tap transformers, to insure they are set to the proper incoming voltage.
- Verify correct belt tension, as well as the belt/pulley alignment. Tighten if needed.
- Prior to energizing the unit, inspect all the electrical connections.
- Power the unit. Bump the motor contactor to check rotation. Three phase motors are synchronized at the factory. If blower motor fans are running backwards, de-energize power to the unit, then swap two of the three incoming electrical lines to obtain proper phasing. Re-check.
- Perform all start up procedures outlined in the installation manual shipped with the unit.
- Fill in the Start Up Information as outlined on the opposite side of this sheet.
- Provide owner with information packet. Explain the thermostat and unit operation.