

INSTALLATION INSTRUCTIONS

⚠ WARNING

Improper installation, adjustment, alteration, ser vice or maintenance can cause property damage, personal injury or loss of life. Installation and ser vice must be performed by a licensed professional HVAC installer or equivalent or service agency.

⚠ CAUTION

As with any mechanical equipment, contact with sharp sheet metal edges can result in personal in jury. Take care while handling this equipment and wear gloves and protective clothing.

Table of Contents

Parts Arrangement	1
Dimensions	2
Shipping and Packing List	3
General	3
Requirements	3
Unit Support	4
Duct Connection	4
Rigging Unit for Lifting	5
Condensate Drains	5
Electrical Connections	7
Unit Power-Up	8
Blower Operation and Adjustments	8
Heating Start-Up	14
Cooling Start-Up	14

KHC092 (7-1/2 Ton)

KHC102 (8-1/2 Ton)

KHC120 (10 Ton)

HEAT PUMP PACKAGED UNITS

506914-04

3/2024

Supersedes 506914-03

⚠ WARNING

To prevent serious injury or death:

- 1- Lock-out/tag-out before performing maintenance.
- 2- If system power is required (e.g., smoke detector maintenance), disable power to blower, remove fan belt where applicable, and ensure all controllers and thermostats are set to the "OFF" position before performing maintenance.
- 3- Always keep hands, hair, clothing, jewelry, tools, etc., away from moving parts.

Defrost Control Board	17
Supply Air Inverter Start-Up	18
Service	21

RETAIN THESE INSTRUCTIONS FOR FUTURE REFERENCE

PARTS ARRANGEMENT

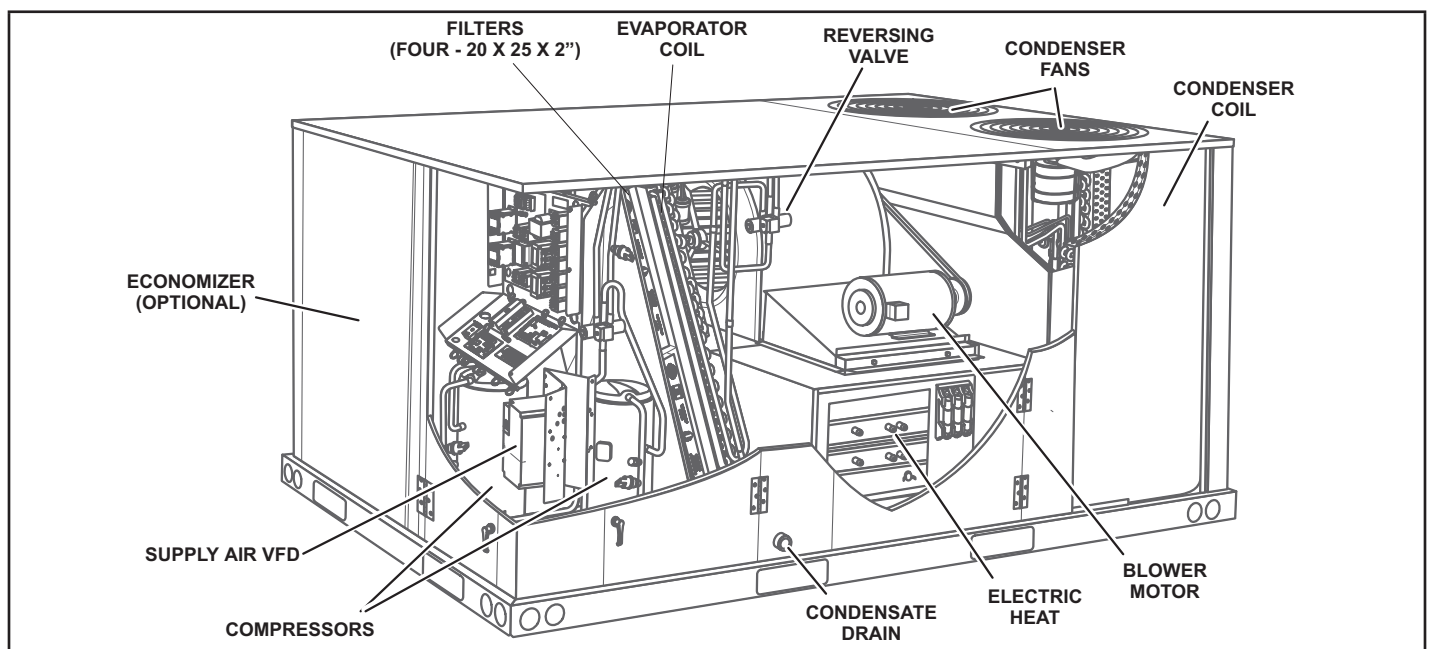

DIMENSIONS

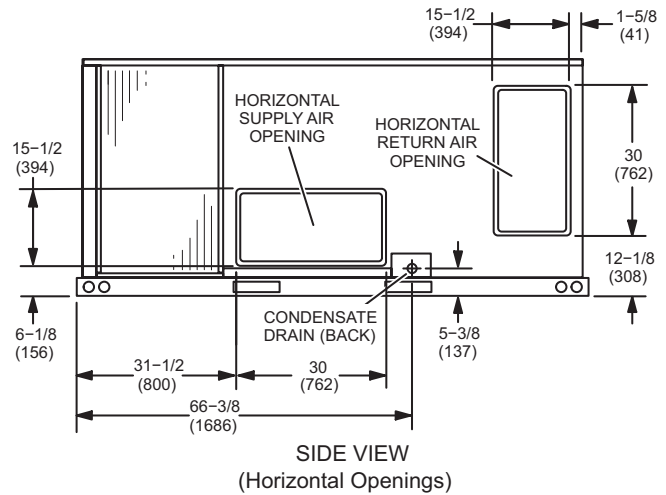
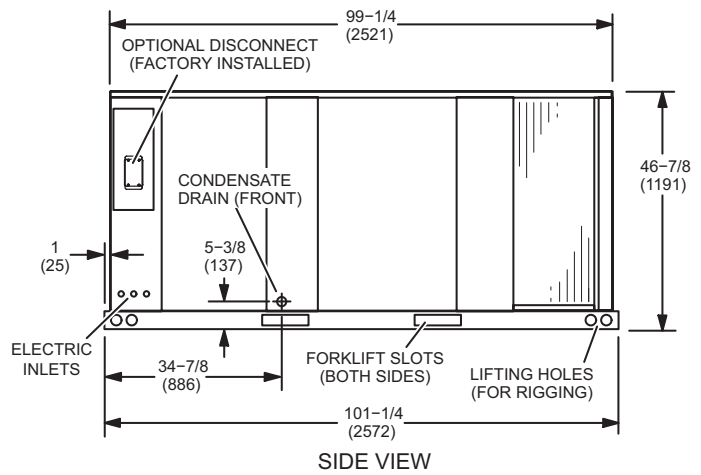
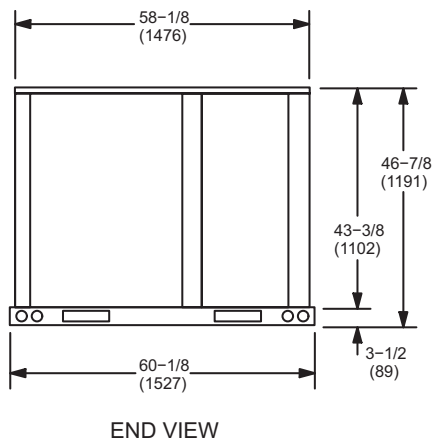
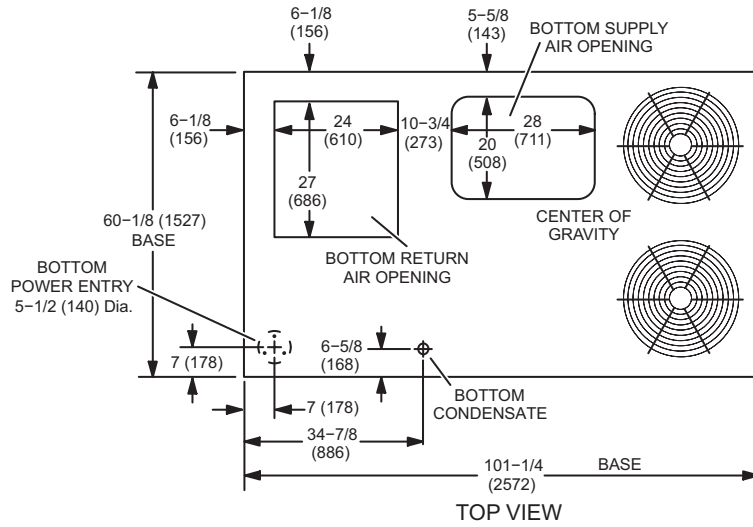

Shipping and Packing List

Package 1 of 1 contains:

- 1 - Assembled unit

Check unit for shipping damage. Receiving party should contact last carrier immediately if shipping damage is found.

General

These instructions are intended as a general guide and do not supersede local codes in any way. Authorities having jurisdiction should be consulted before installation.

KHC units have 7-1/2, 8-1/2, and 10-ton cooling capacities. Optional electric heat is available.

Units are equipped with a supply air inverter. The blower will operate at lower speeds when cooling demand is low and increase to higher speeds when cooling demand is high. Refer to Supply Air Start-Up sections.

Availability of units and options varies by brand.

Requirements

The KHC unit is ETL/CSA certified for outdoor installations only at the clearances to combustible materials listed on unit nameplate and in FIGURE 1.

Installation of KHC heat pumps must conform with standards in National Fire Protection Association (NFPA) "Standard for Installation of Air Conditioning and Ventilating Systems NFPA No. 90A," "Standard for Installation of Residence Type Warm Air Heating and Air conditioning Systems NFPA No. 90B," local municipal building codes and manufacturer's installation instructions.

! NOTICE

Roof Damage!

This system contains both refrigerant and oil. Some rubber roofing material may absorb oil, causing the rubber to swell. Bubbles in the rubber roofing material can cause leaks. Protect the roof surface to avoid exposure to refrigerant and oil during service and installation. Failure to follow this notice could result in damage to roof surface.

The National Electric Code (ANSI/NFPA No. 70-1984) is available from:

National Fire Protection Association
1 Batterymarch Park
PO Box 9101
Quincy, MA 02269-9101

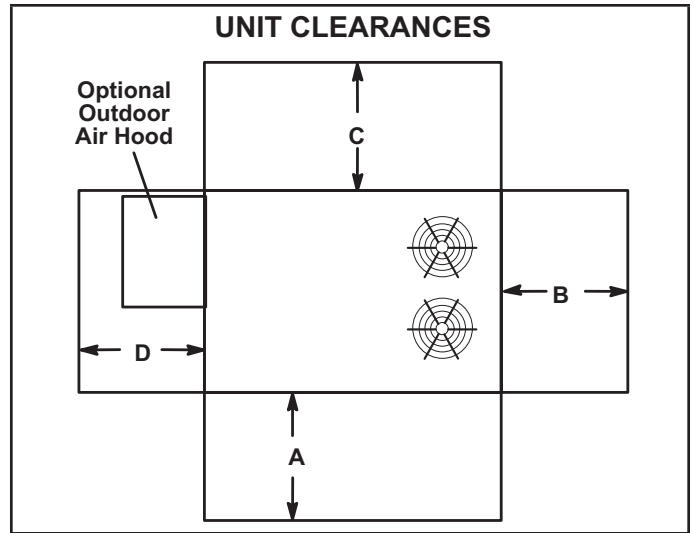

FIGURE 1

¹ Unit Clearance	A in.(mm)	B in.(mm)	C in.(mm)	D in.(mm)	Top Clearance
Service Clearance	60 (1524)	36 (914)	36 (914)	60 (1524)	Unob-structed
Minimum Operation Clearance	36 (914)	36 (914)	36 (914)	36 (914)	Unob-structed

NOTE - Entire perimeter of unit base requires support when elevated above mounting surface.

- ¹ **Service Clearance** - Required for removal of serviceable parts.
- Minimum Operation Clearance** - Required clearance for proper unit operation.

The KHC unit is ETL/CSA certified as a heat pump with cooling and with or without auxiliary electric heat for non-residential use only at the clearances to combustible materials as listed on the unit nameplate and in FIGURE 1.

Installation of ETL/CSA certified units must conform with current standard C273.5 "Installation Requirements for Heat Pumps" and applicable local codes. Authorities having jurisdiction should be consulted before installation.

Use of this unit as a construction heater or air conditioner is not recommended during any phase of construction. Very low return air temperatures, harmful vapors and operation of the unit with clogged or misplaced filters will damage the unit.

If this unit has been used for heating or cooling of buildings or structures under construction, the following conditions must be met or the warranty will be void:

- A room thermostat must control the unit. The use of fixed jumpers that will provide continuous heating or cooling is not allowed.
- A pre-filter must be installed at the entry to the return air duct.
- The return air duct must be provided and sealed to the unit.
- Return air temperature range between 55°F (13°C) and 80°F (27°C) must be maintained.

- Air filters must be replaced and pre-filter must be removed upon construction completion.
- The unit components, duct system, air filters and evaporator coil must be thoroughly cleaned following final construction clean-up.
- The unit operating conditions (including airflow, cooling operation, and heating operation) must be verified according to these installation instructions.

This appliance is not to be used by persons with reduced physical, sensory or mental capabilities, or lack of experience and knowledge, unless they have been given supervision or instruction.

This appliance should not be used by children. Children should be supervised to ensure they do not play with the appliance.

⚠ WARNING	
	Electric shock hazard and danger of explosion. Can cause injury, death or product or property damage. Turn off electrical power to unit before performing any maintenance or servicing operations on the unit.

⚠ IMPORTANT	
The Clean Air Act of 1990 bans the intentional venting of refrigerant (CFC's and HCFC's) as of July 1, 1992. Approved methods of recovery, recycling or reclaiming must be followed. Fines and/or incarceration may be levied for non-compliance.	

Unit Support

NOTE - Securely fasten roof frame to roof per local codes

⚠ CAUTION	
To reduce the likelihood of supply / return air by pass and promote a proper seal with the RTU, duct work / duct drops / diffuser assemblies must be supported independently to the building structure.	

A-Downflow Discharge Application

Roof Mounting with C1CURB

- 1 - The C1CURB roof mounting frame must be installed, flashed and sealed in accordance with the instructions provided with the frame.
- 2 - The C1CURB roof mounting frame should be square and level to 1/16" per linear foot (5mm per linear meter) in any direction.
- 3 - Duct must be attached to the roof mounting frame and not to the unit; supply and return plenums must be installed before setting the unit.

Installer's Roof Mounting Frame

Many types of roof frames can be used to install the unit, depending upon different roof structures. Items to keep in mind when using the building frame or supports are:

- 1 - The unit base is fully enclosed and insulated, so an enclosed frame is not required.
- 2 - The frames or supports must be constructed with non-combustible materials and should be square and level to 1/16" per linear foot (5mm per linear meter) in any direction.
- 3 - Frame or supports must be high enough to prevent any form of moisture from entering unit. Recommended minimum frame height is 14" (356mm).
- 4 - Duct must be attached to the roof mounting frame and not to the unit. Supply and return plenums must be installed before setting the unit.
- 5 - Units require support along all four sides of unit base. Supports must be constructed of steel or suitably treated wood materials.

NOTE - When installing unit on a combustible surface for downflow discharge applications, the C1CURB roof mounting frame is required.

B-Horizontal Discharge Applications

- 1 - Units installed in horizontal airflow applications must use a horizontal conversion kit (K1HECK00).
- 2 - Specified installation clearances must be maintained when installing units. Refer to FIGURE 1.
- 3 - Top of support slab should be at least 4" (102mm) above the finished grade and located so no run-off water from higher ground can collect around the unit.
- 4 - Units require support along all four sides of unit base. Supports must be constructed of steel or suitably treated wood materials.

Duct Connection

All exterior ducts, joints, and openings in roof or building walls must be insulated and weatherproofed with flashing and sealing compounds in accordance with applicable codes. Any duct passing through an unconditioned space must be insulated.

⚠ CAUTION	
In downflow applications, do not drill or punch holes in base of unit. Leaking in roof may occur if unit base is punctured.	

Rigging Unit for Lifting

- 1 - Detach wooden base protection before rigging.
- 2 - Connect rigging to the unit base using both holes in each corner. See FIGURE 2.
- 3 - All panels must be in place for rigging.
- 4 - Place field-provided H-style pick in place just above top edge of unit. Frame must be of adequate strength and length. (H-style pick prevents damage to unit.)

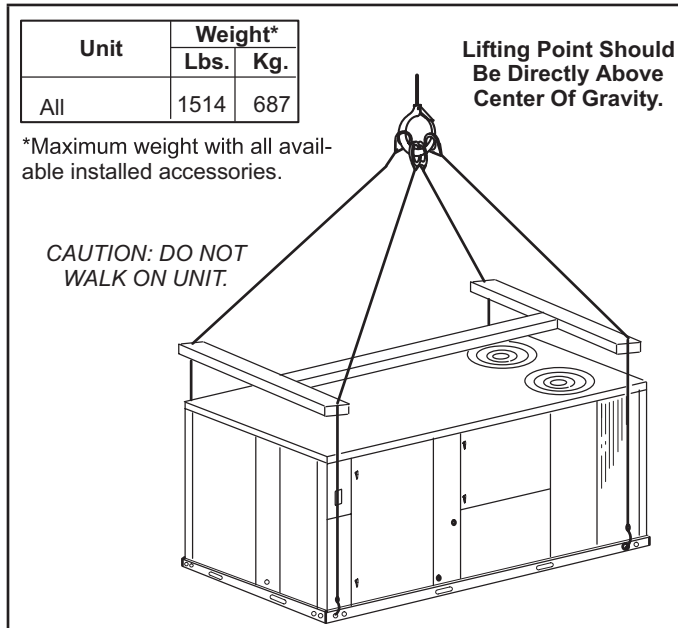

FIGURE 2

Condensate Drains

Make drain connection to the 1" N.P.T. drain coupling provided on unit.

NOTE - The drain pan is made with a glass reinforced engineered plastic capable of withstanding typical joint torque but can be damaged with excessive force. Tighten pipe nipple hand tight and turn an additional quarter turn.

A trap must be installed between drain connection and an open vent for proper condensate removal. See FIGURE 3 or FIGURE 4. It is sometimes acceptable to drain condensate onto the roof or grade; however, a tee should be fitted to the trap to direct condensate downward. The condensate line must be vented. Check local codes concerning condensate disposal. Refer to page 2 and page 3 for condensate drain location.

Units are shipped with the drain coupling facing the front of the unit. Condensate can be drained from the back or bottom of the unit with the following modifications. The unit can be installed in either downflow or horizontal air discharge regardless of condensate drain location.

Rear Drain Connection

- 1 - Remove heat access door. See FIGURE 5.
- 2 - Remove filter access door. Refer to FIGURE 5.
- 3 - Remove eight screws holding condensate drain mullion and remove mullion.

CONDENSATE SIDE DRAIN CONNECTION

CAULK AROUND CONDENSATE COUPLING

NOTE - Allow clearance to open doors when installing condensate piping.

Minimum Pitch
1" (25 mm) per
10' (3 m) of line

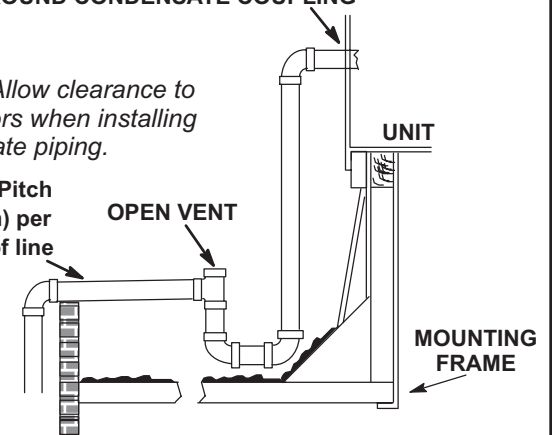

FIGURE 3

CONDENSATE BOTTOM DRAIN CONNECTION

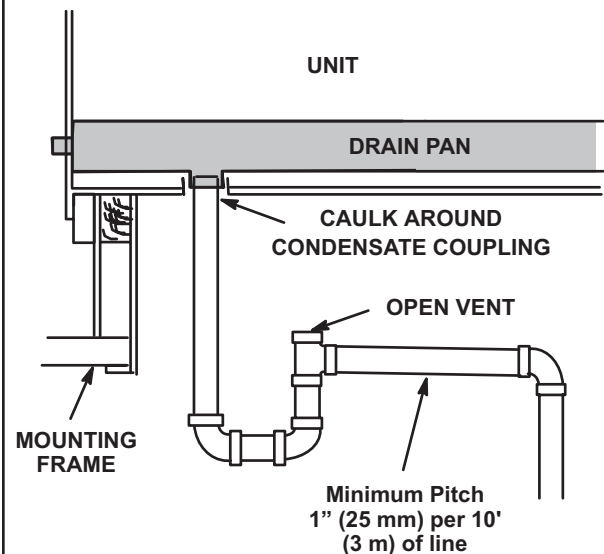

FIGURE 4

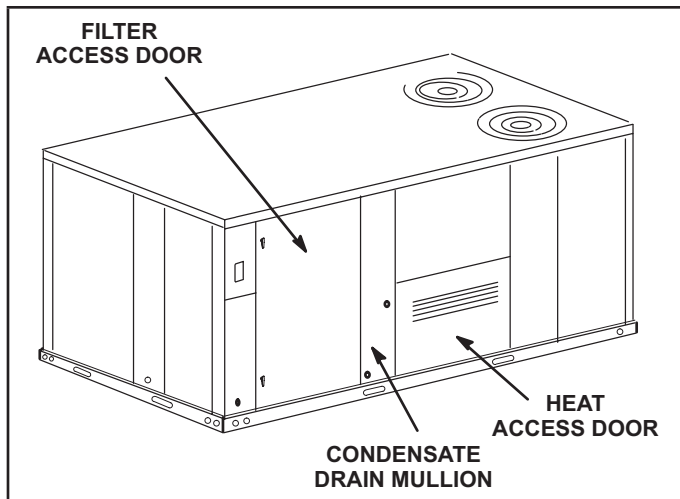

FIGURE 5

- 4 - Lift front edge of the drain pan (to clear bottom drain plug) and slide drain pan out of unit. See FIGURE 6.

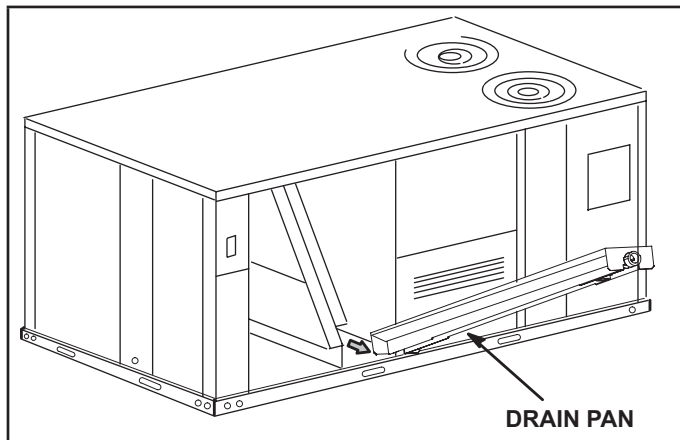

FIGURE 6

- 5 - Make sure the cap over the unit bottom drain hole is secure.
- 6 - Rotate the drain pan until the downward slope is toward the back of the unit. Slide the drain pan back into the unit. Be careful not to dislodge the cap over the bottom drain hole.
- 7 - From the back side of the unit, pull the drain pan coupling through the rear condensate opening.
- 8 - Replace the condensate drain mullion and reinstall eight screws.
- 9 - Reinstall access doors.

Bottom Drain Connection

- 1 - Remove heat access door. See FIGURE 5.
- 2 - Remove filter access door. Refer to FIGURE 5.
- 3 - Remove eight screws holding condensate drain mullion and remove mullion.
- 4 - Lift front edge of the drain pan (to clear bottom drain plug) and slide drain pan out of unit. See FIGURE 6.
- 5 - Turn the drain pan upside down and drill a pilot hole through the bottom of the drain pan in the center of the coupling. See FIGURE 7.

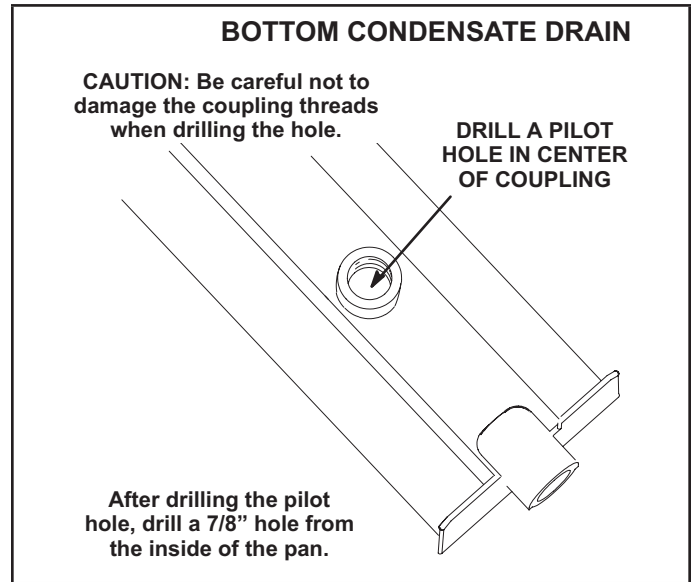

FIGURE 7

- 6 - From the inside of the pan, use a Vari-Bit® bit to enlarge the hole to 7/8". Do not damage coupling threads.
- 7 - Remove the cap over the unit bottom drain hole.
- 8 - Slide the drain pan back into the unit.
- 9 - From the back side of the unit, pull the drain pan coupling through the rear condensate opening.
- 10 - From the front side of the unit, move the drain pan until the bottom coupling settles into the unit bottom drain opening. Once in place, check to make sure the coupling is still positioned through the rear condensate drain hole.
- 11 - Use a field-provided 1" plug to seal side drain connection.
- 12 - Replace the condensate drain mullion and reinstall eight screws.
- 13 - Reinstall access doors.

Electrical Connections

POWER SUPPLY

A-Wiring

Route field wiring in conduit between bottom power entry disconnect. See FIGURE 8. This does not supersede local codes or authorities having jurisdiction.

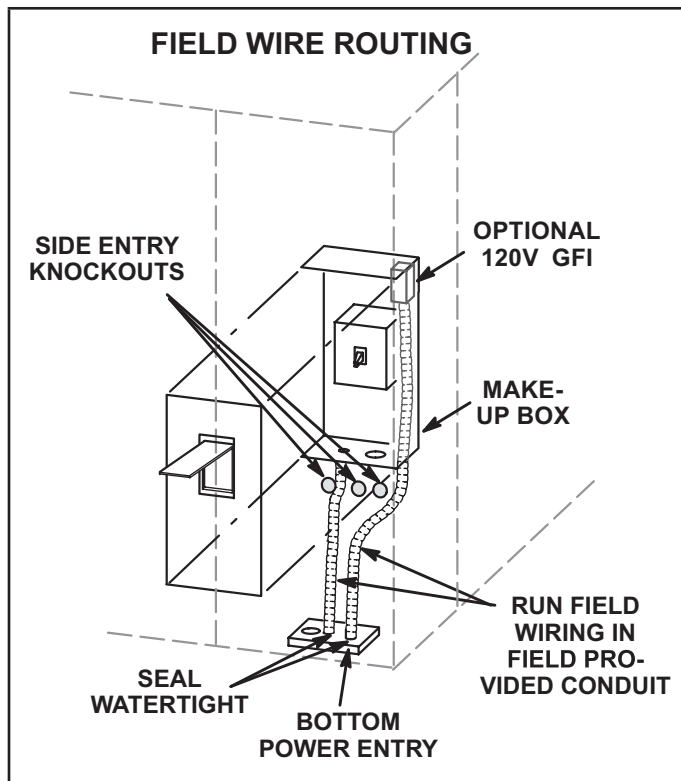

FIGURE 8

Do not apply power or close disconnect switch until installation is complete. Refer to start-up directions.

Refer to unit nameplate for minimum circuit ampacity and maximum fuse size.

- 1 - 230,460,575 volt units are factory wired. For 208V supply, disconnect the pink wire (230V) at all control power transformer(s). Reconnect the pink wire to terminal marked 208 on power transformer(s). Tape the exposed end of the 230V pink wire.
- 2 - Route power through the bottom power entry area and connect to L1, L2, and L3 on the bottom of F4 in the control box. Route power to TB2 on units equipped with electric heat. Route power to S48 disconnect switch when the option is factory-installed. See unit wiring diagram.
- 3 - Connect separate 120v wiring to optional GFCI outlet pigtails. Route field wiring in conduit between bottom power entry and GFCI. See FIGURE 8.

B-Unbalanced Three-Phase Voltage - VFD Units Only

Units equipped with an optional inverter (VFD) are designed to operate on balanced, three-phase power. Operating units on unbalanced three-phase power will reduce the reliability of all electrical components in the unit. Unbalanced power is a result of power delivery system supplied by the local utility company.

Factory-installed inverters are sized to drive blower motors with an equivalent current rating using balanced three-phase power. When unbalanced three-phase power is supplied; the installer must replace the existing factory-installed inverter with an inverter that has a higher current rating to allow for the imbalance. Use TABLE 1 to determine the appropriate replacement inverter.

TABLE 1
INVERTER UP-SIZING

Factory-Installed Inverter HP	Replacement Inverter HP
2	5
3	7-1/2
5	10

CONTROL WIRING

A-Thermostat Location

Room thermostat mounts vertically on a standard 2" X 4" handy box or on any non-conductive flat surface.

Locate thermostat approximately 5 feet (1524 mm) above the floor in an area with good air circulation at average temperature. Avoid locating the room thermostat where it might be affected by:

- drafts or dead spots behind doors and in corners
- hot or cold air from ducts
- radiant heat from sun or appliances
- concealed pipes and chimneys

IMPORTANT - Unless field thermostat wires are rated for maximum unit voltage, they must be routed away from line voltage wiring.

B-Control Wiring

- 1 - Route thermostat cable or wires from subbase to unit control box (refer to unit dimensions to locate bottom and side power entry).

IMPORTANT - Unless field thermostat wires are rated for maximum unit voltage, they must be routed away from line voltage wiring. Use wire ties located near the front of the control section to secure thermostat cable.

Use 18 AWG wire for all applications using remotely installed electro-mechanical and electronic thermostats.

- 2 - Install thermostat assembly in accordance with instructions provided with thermostat.

- 3 - Connect thermostat wiring to TB1 terminal board on the lower side of the controls hat section. Wire as shown in FIGURE 9 for electro-mechanical and electronic thermostats. If using other temperature control devices or energy management systems see instructions and wiring diagram provided by manufacturer.
- 4 - Verify the unit configuration DIP switch settings match the nameplate

IMPORTANT - Terminal connections at the wall plate or subbase must be made securely. Loose control wire connections may allow unit to operate but not with proper response to room demand.

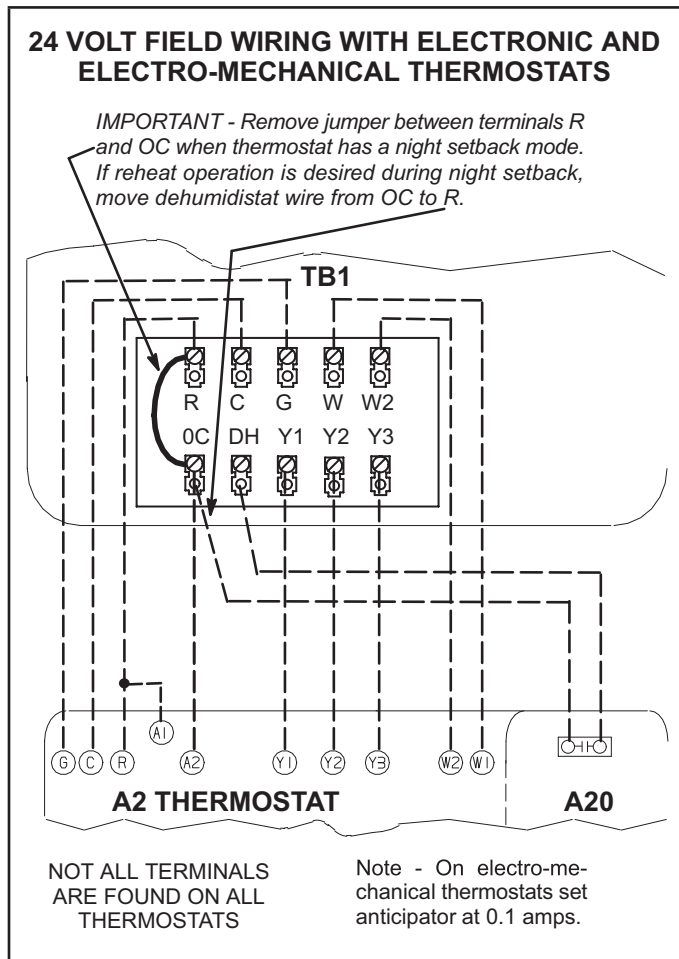

FIGURE 9

Unit Power-Up

A-General

- 1 - Make sure that unit is installed in accordance with the installation instructions and applicable codes.
- 2 - Inspect all electrical wiring, both field and factory installed, for loose connections. Tighten as required.
- 3 - Check to ensure that refrigerant lines do not rub against the cabinet or against other refrigerant lines.

- 4 - Check voltage at main unit power connection. Voltage must be within range listed on nameplate. If not, consult power company and have voltage condition corrected before starting unit.
- 5 - Make sure filters are in place before start-up.
- 6 - Make sure there is no heating, cooling, or blower demand from thermostat. Apply power to unit.

Blower Operation and Adjustments

A-Three Phase Scroll Compressor Voltage Phasing

Three phase scroll compressors must be phased sequentially to ensure correct compressor and blower rotation and operation. Compressor and blower are wired in phase at the factory. Power wires are color-coded as follows: line 1-red, line 2-yellow, line 3-blue.

- 1 - Observe suction and discharge pressures and blower rotation on unit start-up.

If pressure differential is not observed or blower rotation is not correct:

- 2 - Suction pressure must drop, discharge pressure must rise, and blower rotation must match rotation marking.
- 3 - Disconnect all remote electrical power supplies.
- 4 - Reverse any two field-installed wires connected to the line side of TB13, TB2, or F4. Do not reverse wires at blower contactor or compressors.
- 5 - Make sure the connections are tight.

Discharge and suction pressures should operate at their normal start-up ranges.

Belt-Driven Supply Air Inverter Units - Units are equipped with a phase monitor located in the control compartment. The phase monitor will detect the phasing of incoming power. If the incoming power is out of phase or if any of the three phases are lost, the indicating LED on the phase monitor will turn red and the unit will not start. In normal operation with correct incoming power phasing, the LED will be green.

B-Blower Operation

Initiate blower demand at thermostat according to instructions provided with thermostat. Unit will cycle on thermostat demand. The following steps apply to applications using a typical electro-mechanical thermostat.

- 1 - Blower operation is manually set at the thermostat subbase fan switch. With fan switch in **ON** position, blowers will operate continuously.
- 2 - With fan switch in **AUTO** position, the blowers will cycle with demand. Blowers and entire unit will be off when system switch is in **OFF** position.

C-Blower Access

The blower assembly is secured to a sliding frame which allows the blower motor to be pulled out of the unit. See FIGURE 10.

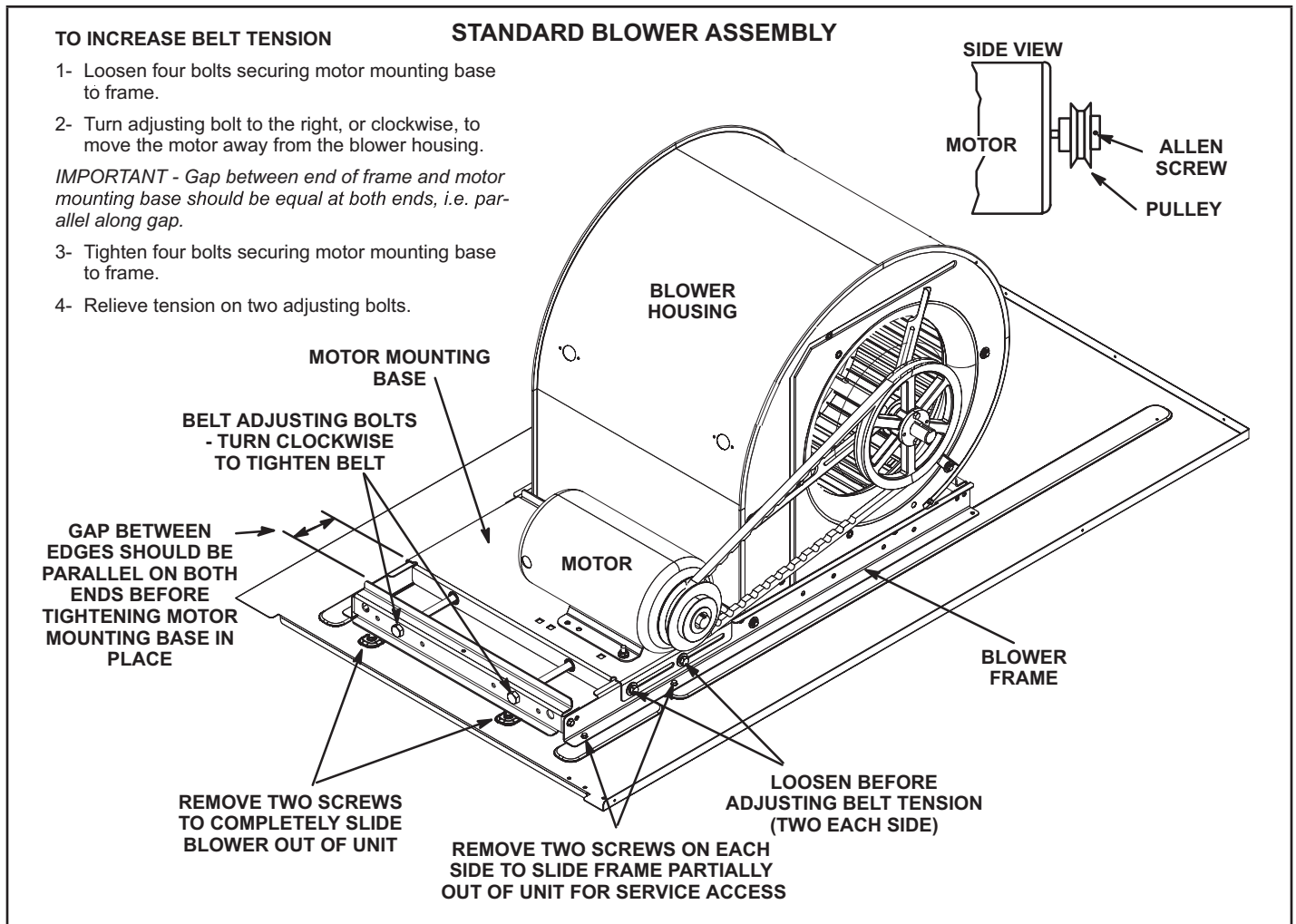

FIGURE 10

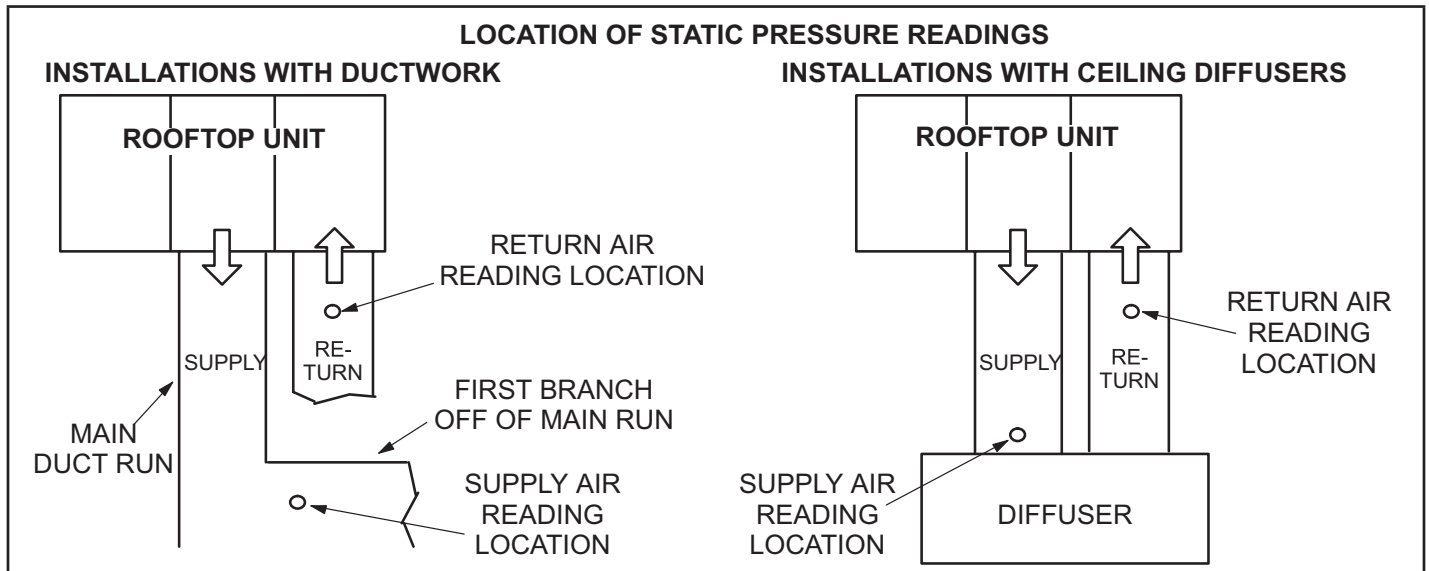

FIGURE 11

Belt Drive Blowers

- 1 - Loosen the reusable wire tie which secures the blower wiring to the blower motor mounting plate.
- 2 - Remove and retain screws on either side of sliding frame. Pull frame toward outside of unit.
- 3 - Slide frame back into original position when finished servicing. Reattach the blower wiring in the previous location on the blower motor base using the wire tie.
- 4 - Replace retained screws on either side of the sliding frame.

D-Determining Unit CFM

IMPORTANT - Belt-driven supply air inverter units are factory-set to run the blower at full speed when there is a blower (G) demand without a heating or cooling demand. Use the following procedure to adjust motor pulley to deliver the full load cooling or heating CFM. See Belt-Driven Supply Air Inverter Start-Up section to set blower CFM for all modes once the motor pulley is set.

- 1 - The following measurements must be made with a dry indoor coil. Run blower without a cooling demand. Measure the indoor blower shaft RPM. Air filters must be in place when measurements are taken.
- 2 - With all access panels in place, measure static pressure external to unit (from supply to return). Blower performance data is based on static pressure readings taken in locations shown in FIGURE 11.

NOTE - Static pressure readings can vary if not taken where shown.

- 3 - Referring to page 14, page 15, or page 16, use static pressure and RPM readings to determine unit CFM. Use page 17 when installing units with any of the optional accessories listed.
- 4 - The blower RPM can be adjusted at the motor pulley. Loosen Allen screw and turn adjustable pulley clockwise to increase CFM. Turn counterclockwise to decrease CFM. See FIGURE 10. Do not exceed minimum and maximum number of pulley turns as shown in TABLE 2.

TABLE 2

MINIMUM AND MAXIMUM PULLEY ADJUSTMENT

Belt	Minimum Turns Open	Maximum Turns Open
A Section	0	5
B Section	1*	6

*No minimum number of turns open when B belt is used on pulleys 6" O.D. or larger.

E-Blower Belt Adjustment

Maximum life and wear can be obtained from belts only if proper pulley alignment and belt tension are maintained. Tension new belts after a 24-48 hour period of operation. This will allow belt to stretch and seat in the pulley grooves. Make sure blower and motor pulleys are aligned as shown in FIGURE 12.

- 1 - Loosen four bolts securing motor base to mounting frame. See FIGURE 10.

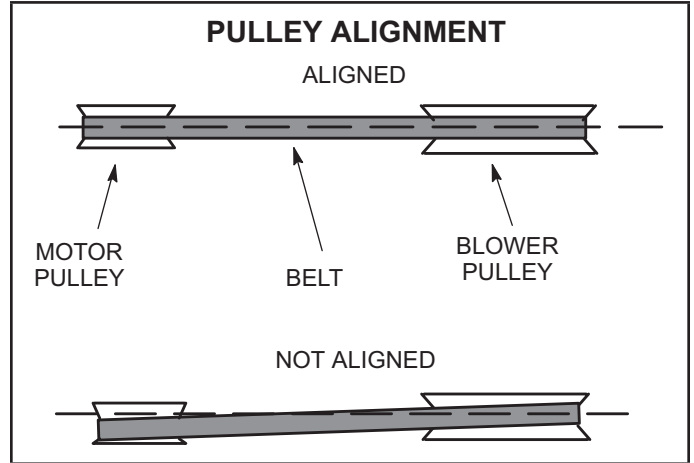

FIGURE 12

- 2 - To increase belt tension -
Turn both adjusting bolts to the right, or clockwise, to move the motor outward and tighten the belt. This increases the distance between the blower motor and the blower housing.
To loosen belt tension -
Turn the adjusting bolts to the left, or counterclockwise to loosen belt tension.

IMPORTANT - Align top edges of blower motor base and mounting frame base parallel before tightening four bolts on the side of base. Motor shaft and blower shaft must be parallel.

- 3 - Tighten two bolts on each side of the motor mounting base. This secures the mounting base to the frame.
- 4 - Relieve tension adjusting bolts.

F-Check Belt Tension

Overtensioning belts shortens belt and bearing life. Check belt tension as follows:

- 1 - Measure span length X. See FIGURE 13.
- 2 - Apply perpendicular force to center of span (X) with enough pressure to deflect belt $1/64$ " for every inch of span length or 1.5mm per 100mm of span length.
Example: Deflection distance of a 40" span would be $40/64$ " or $5/8$ ".
Example: Deflection distance of a 400mm span would be 6mm.
- 3 - Measure belt deflection force. For a new 2 and 3hp belt, the deflection force should be 5.0-7.0 lbs. (35-48kPa). For a new 5hp belt, the deflection force should be 7-10lbs. (48-69kPa).
- 4 - A force below these values indicates an undertensioned belt. A force above these values indicates an overtensioned belt.

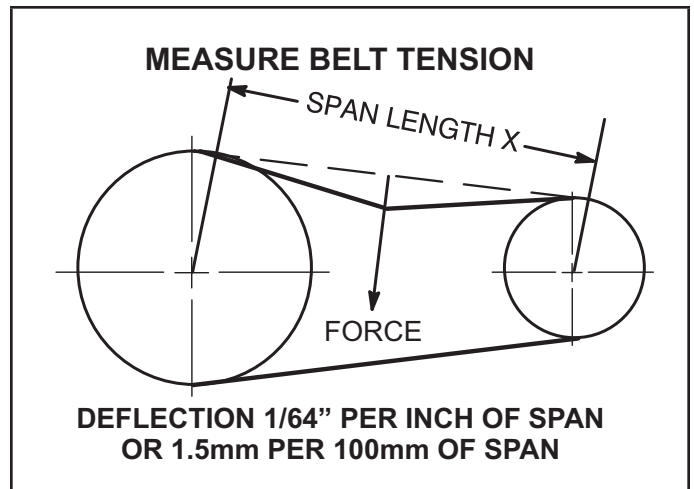

FIGURE 13

G-Field-Furnished Blower Drives

For field-furnished blower drives, use page 14 through page 15 to determine BHP and RPM required. Reference page 17 to determine the drive number. Reference TABLE 3 for drive component manufacturer's numbers.

BLOWER DATA

KHC092, 102, 120 BELT DRIVE BLOWER – BASE UNIT

BLOWER TABLE INCLUDES RESISTANCE FOR BASE UNIT ONLY (NO HEAT SECTION) WITH DRY INDOOR COIL AND AIR FILTERS IN PLACE. FOR ALL UNITS ADD:

- 1 - Wet indoor coil air resistance of selected unit.
- 2 - Any factory installed options air resistance (heat section, economizer, etc.)
- 3 - Any field installed accessories air resistance (duct resistance, diffuser, etc.)

Then determine from blower table blower motor output required.

See page 13 for blower motors and drives.

See page 13 for wet coil and option/accessory air resistance data.

MINIMUM AIR VOLUME REQUIRED FOR USE WITH OPTIONAL ELECTRIC HEAT (Maximum Static Pressure - 2.0 in. w.g.)

7.5kW, 15 kW, 22.5 kW, 30 kW and 45 kW - 2800 cfm

60 kW - 4000 cfm

Total Air Volume ofm	Total Static Pressure - in. w.g.																										
	0.2		0.4		0.6		0.8		1.0		1.2		1.4		1.6		1.8		2.0		2.2		2.4		2.6		
	RPM	BHP	RPM	BHP	RPM	BHP	RPM	BHP	RPM	BHP	RPM	BHP	RPM	BHP	RPM	BHP	RPM	BHP	RPM	BHP	RPM	BHP	RPM	BHP	RPM	BHP	RPM
1750	480	0.19	548	0.39	618	0.57	689	0.70	758	0.81	824	0.92	885	1.07	941	1.23	992	1.40	1039	1.55	1084	1.70	1128	1.85	1156	2.08	
2000	492	0.27	560	0.47	629	0.64	700	0.77	768	0.88	832	1.00	892	1.16	946	1.32	995	1.48	1041	1.65	1085	1.81	1127	1.97	1160	2.13	
2250	505	0.35	573	0.55	643	0.72	713	0.85	780	0.97	842	1.10	900	1.25	952	1.42	999	1.59	1044	1.76	1087	1.93	1127	2.10	1164	2.27	
2500	520	0.45	588	0.64	658	0.81	727	0.94	793	1.07	853	1.21	909	1.37	959	1.54	1005	1.71	1048	1.89	1089	2.07	1127	2.25	1166	2.42	
2750	536	0.55	604	0.74	674	0.91	743	1.05	806	1.19	865	1.34	919	1.50	968	1.67	1012	1.86	1053	2.04	1092	2.23	1129	2.41	1167	2.60	
3000	553	0.66	622	0.85	692	1.02	760	1.17	821	1.32	878	1.48	930	1.64	977	1.83	1020	2.02	1059	2.21	1096	2.41	1133	2.60	1170	2.79	
3250	572	0.77	641	0.98	712	1.15	778	1.32	837	1.48	892	1.64	942	1.81	988	2.00	1028	2.20	1066	2.41	1102	2.61	1138	2.81	1174	3.01	
3500	592	0.90	663	1.12	733	1.31	798	1.48	854	1.65	907	1.82	955	1.99	999	2.19	1038	2.41	1074	2.63	1109	2.84	1144	3.04	1180	3.24	
3750	614	1.04	687	1.28	756	1.48	818	1.66	872	1.83	922	2.01	969	2.19	1010	2.41	1048	2.64	1084	2.87	1118	3.09	1152	3.29	1188	3.50	
4000	639	1.22	712	1.47	780	1.67	838	1.85	890	2.03	939	2.22	983	2.42	1023	2.65	1060	2.90	1095	3.14	1128	3.36	1162	3.57	1198	3.77	
4250	666	1.42	740	1.68	804	1.88	859	2.06	909	2.25	956	2.45	998	2.67	1036	2.92	1072	3.18	1106	3.42	1139	3.65	1172	3.86	1208	4.07	
4500	697	1.65	769	1.91	829	2.10	881	2.28	929	2.48	973	2.71	1013	2.95	1050	3.22	1085	3.48	1118	3.73	1151	3.96	1184	4.17	1221	4.39	
4750	729	1.91	798	2.15	854	2.34	903	2.53	948	2.75	991	3.00	1030	3.27	1065	3.55	1099	3.81	1132	4.06	1164	4.29	1198	4.51	1235	4.74	
5000	763	2.18	826	2.41	878	2.60	925	2.81	968	3.05	1009	3.33	1046	3.61	1081	3.90	1114	4.17	1146	4.42	1178	4.65	1212	4.87	1250	5.09	
5250	797	2.47	854	2.69	903	2.90	947	3.12	989	3.39	1028	3.69	1064	3.99	1098	4.28	1130	4.55	1162	4.80	1194	5.02	1228	5.24	1266	5.47	
5500	830	2.78	882	3.00	927	3.22	969	3.48	1010	3.77	1047	4.09	1083	4.40	1116	4.69	1147	4.96	1179	5.20	1211	5.42	1246	5.63	---	---	
5750	861	3.11	908	3.34	951	3.58	992	3.87	1031	4.19	1068	4.52	1102	4.84	1134	5.12	1165	5.38	1196	5.61	---	---	---	---	---	---	
6000	890	3.45	935	3.71	976	3.98	1016	4.31	1053	4.65	1089	4.99	1122	5.30	1153	5.58	---	---	---	---	---	---	---	---	---	---	
6250	918	3.84	961	4.12	1001	4.43	1040	4.79	1076	5.14	1110	5.48	---	---	---	---	---	---	---	---	---	---	---	---	---	---	

BLOWER DATA

FACTORY INSTALLED BELT DRIVE KIT SPECIFICATIONS

Nominal hp	Maximum hp	Drive Kit Number	RPM Range
2	2.3	1	590 - 890
2	2.3	2	800 - 1105
2	2.3	3	795 - 1195
3	3.45	4	730 - 970
3	3.45	5	940 - 1200
3	3.45	6	1015 - 1300
5	5.75	10	900 - 1135
5	5.75	11	1040 - 1315
5	5.75	12	1125 - 1425

POWER EXHAUST FAN PERFORMANCE

Return Air System Static Pressure	Air Volume Exhausted
in. w.g.	cfm
0	3175
0.05	2955
0.10	2685
0.15	2410
0.20	2165
0.25	1920
0.30	1420
0.35	1200

FACTORY INSTALLED OPTIONS/FIELD INSTALLED ACCESSORY AIR RESISTANCE - in. w.g.

Air Volume cfm	Wet Indoor Coil	Electric Heat	Economizer	Filters		Return Air Adapter Plate
	KHC092, 102, 120			MERV 8	MERV 10	
1750	0.04	0.03	0.05	0.01	0.03	0.00
2000	0.05	0.03	0.06	0.01	0.03	0.00
2250	0.06	0.04	0.08	0.01	0.04	0.00
2500	0.07	0.04	0.11	0.01	0.05	0.00
2750	0.08	0.05	0.12	0.02	0.05	0.00
3000	0.10	0.06	0.13	0.02	0.06	0.02
3250	0.11	0.06	0.15	0.02	0.06	0.02
3500	0.12	0.09	0.15	0.03	0.07	0.04
3750	0.14	0.09	0.15	0.03	0.08	0.07
4000	0.15	0.09	0.19	0.04	0.08	0.09
4250	0.17	0.13	0.19	0.04	0.09	0.11
4500	0.19	0.14	0.22	0.04	0.09	0.12
4750	0.20	0.17	0.25	0.05	0.10	0.16
5000	0.22	0.20	0.29	0.06	0.10	0.18
5250	0.24	0.22	0.32	0.06	0.11	0.19
5500	0.25	0.25	0.34	0.07	0.12	0.22
5750	0.27	0.31	0.45	0.07	0.12	0.25
6000	0.29	0.33	0.52	0.08	0.13	0.27

**TABLE 3
MANUFACTURER'S NUMBERS**

DRIVE NO.	DRIVE COMPONENTS					
	ADJUSTABLE SHEAVE		FIXED SHEAVE		BELT	
	BROWNING NO.	OEM PART NO.	BROWNING NO.	OEM PART NO.	BROWNING NO.	OEM PART NO.
1	1VP34x7/8	31K6901	AK61x1	100244-20	AX54	100245-25
2	1VP40x7/8	79J0301	AK59x1	31K6801	AX55	100245-26
3	1VP34x7/8	31K6901	AK46x1	100244-17	AX52	100245-33
4	1VP44x7/8	53J9601	AK74x1	100244-21	AX58	100245-34
5	1VP50x7/8	98J0001	AK69x1	37L4701	AX58	100245-34
6	1VP50x7/8	98J0001	AK64x1	12L2501	AX57	100245-28
10	1VP50x1-1/8	P-8-1977	BK77x1	49K4001	BX59	59A5001
11	1VP50x1-1/8	P-8-1977	BK67x1	100244-24	BX57	78L5301
12	1VP50x1-1/8	P-8-1977	BK62x1	100244-23	BX56	100245-11

Heating Start-Up

1 - Set thermostat or temperature control device to initiate a first-stage heating demand.

A first-stage heating demand (W1) will energize compressors 1 and 2. Both outdoor fans are energized with a W1 demand.

NOTE - L1 and L2 reversing valves are de-energized in the heating mode.

Units With Optional Electric Heat -

An increased heating demand (W2) will energize electric heat. Electric heat is also energized during the defrost cycle (W1) to maintain discharge air temperature.

Cooling Start-Up

⚠ IMPORTANT

If unit is equipped with a crankcase heater. Make sure heater is energized 24 hours before unit start-up to prevent compressor damage as a result of slugging.

A-Start-Up

Supply Air Inverter Units - Refer to the Inverter Start-Up section for further instruction on blower control. See TABLE 12 for full details on unit operation.

Compressor 1 is a two-stage compressor. Compressor 2 is a single-stage compressor.

- 1 - Initiate first, second, and third stage cooling demands according to instructions provided with thermostat.
- 2 - *No Economizer Installed in Unit -*
See TABLE 4 for cooling operation.

Units Equipped With Economizer -

When outdoor air is suitable, any combination of thermostat demands will energize the economizer. See TABLE 5 for cooling operation.

3 - Refrigerant circuits are factory charged with HCFC-410A refrigerant. See unit rating plate for correct amount of charge.

4 - Units contain two refrigerant circuits or systems. See FIGURE 14.

**TABLE 4
COOLING OPERATION - NO ECONOMIZER**

T'Stat	Compressors	OD Fans
Y1	Compr. 1 Low	B5 On
Y1 + Y2	Compr. 1 Low; Compr. 2 On	Both On
Y1 + Y2 + Y3	Compr. 1 High; Compr. 2 On	Both On

**TABLE 5
COOLING OPERATION - WITH ECONOMIZER**

T'Stat	Compressors	OD Fans
Y1	Off	Off
Y1 + Y2	Compr. 1 Low	B5 On
Y1 + Y2 + Y3	Compr. 1 High	B5 On

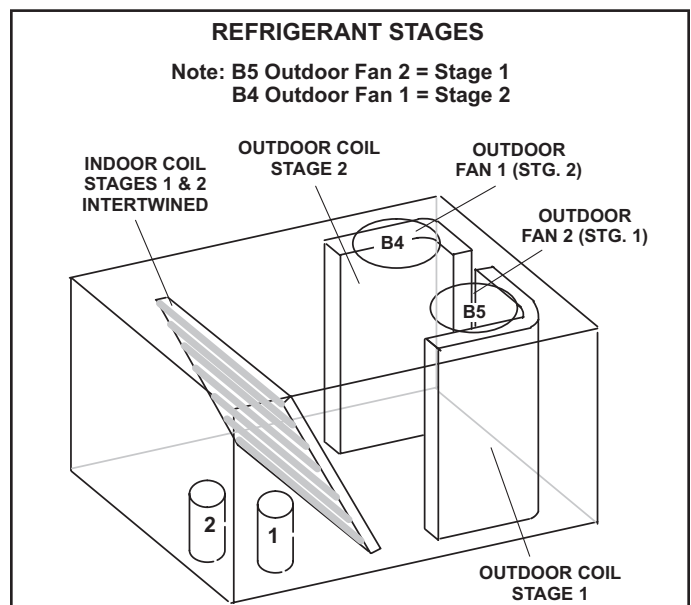

FIGURE 14

B-Refrigerant Charge and Check

WARNING - Do not exceed nameplate charge under any condition. This unit is factory charged and should require no further adjustment. If the system requires additional refrigerant, reclaim the charge, evacuate the system, and add required nameplate charge.

NOTE - System charging is not recommended below 60°F (15°C). In temperatures below 60°F (15°C), the charge must be weighed into the system.

If weighing facilities are not available, or to check the charge, use the following procedure:

- 1 - Attach gauge manifolds and operate unit in cooling mode with economizer disabled until system stabilizes (approximately five minutes).
- 2 - Check each system separately with all stages operating.
- 3 - Use a thermometer to accurately measure the outdoor ambient temperature.
- 4 - Apply the outdoor temperature to TABLE 6 through TABLE 8 to determine normal operating pressures. Pressures are listed for sea level applications at 80°F dry bulb and 67°F wet bulb return air.
- 5 - Compare the normal operating pressures to the pressures obtained from the gauges. Minor variations in these pressures may be expected due to differences in installations. Significant differences could mean that the system is not properly charged or that a problem exists with some component in the system. **Correct any system problems before proceeding.**

TABLE 6

KHC092S NORMAL OPERATING PRESSURES

Outdoor Coil Entering Air Temp	CIRCUIT 1		CIRCUIT 2	
	Dis. ± 10 psig	Suc. ± 5 psig	Dis. ± 10 psig	Suc. ± 5 psig
65°F	256	132	265	137
75°F	293	133	304	138
85°F	334	135	351	140
95°F	380	137	401	142
105°F	432	140	456	144
115°F	491	143	519	147

TABLE 7

KHC102S NORMAL OPERATING PRESSURES

Outdoor Coil Entering Air Temp	CIRCUIT 1		CIRCUIT 2	
	Dis. ± 10 psig	Suc. ± 5 psig	Dis. ± 10 psig	Suc. ± 5 psig
65°F	255	128	250	139
75°F	295	128	291	141
85°F	334	129	329	143
95°F	376	131	375	145
105°F	426	133	425	147
115°F	478	136	479	150

TABLE 8

KHC150S NORMAL OPERATING PRESSURES

Outdoor Coil Entering Air Temp	CIRCUIT 1		CIRCUIT 2	
	Dis. ± 10 psig	Suc. ± 5 psig	Dis. ± 10 psig	Suc. ± 5 psig
65°F	250	127	267	128
75°F	286	128	306	129
85°F	326	128	348	131
95°F	368	129	395	133
105°F	415	131	445	136
115°F	469	133	502	141

- 6 - If discharge pressure is high, remove refrigerant from the system. If discharge pressure is low, add refrigerant to the system.
 - Add or remove charge in increments.
 - Allow the system to stabilize each time refrigerant is added or removed.
- 7 - Use the following approach method along with the normal operating pressures to confirm readings.

C-Charge Verification - Approach Method - AHRI Testing

- 1 - Using the same thermometer, compare liquid temperature to outdoor ambient temperature.
Approach Temperature = Liquid temperature (at condenser outlet) minus ambient temperature.
- 2 - Approach temperature should match values in TABLE 9. An approach temperature greater than value shown indicates an undercharge. An approach temperature less than value shown indicates an overcharge.
- 3 - The approach method is not valid for grossly over or undercharged systems. Use TABLE 6 through TABLE 8 as a guide for typical operating pressures.

TABLE 9

Approach Temperature

Unit	Liquid Temp. Minus Ambient Temp.	
	1st Stage	2nd Stage
092S	5°F ± 1 (2.8°C ± 0.5)	4°F ± 1 (2.2°C ± 0.5)
102S	5°F ± 1 (2.8°C ± 0.5)	5°F ± 1 (2.8°C ± 0.5)
120S	4°F ± 1 (2.2°C ± 0.5)	7°F ± 1 (3.9°C ± 0.5)

D-Compressor Controls

1 - High Pressure Switches (S4, S7)

Compressor circuits are protected by a high pressure switch which cuts out at 640 psig \pm 10 psig (4413 kPa \pm 70 kPa).

2 - Freezestats (S49, S50)

Switches de-energize compressors when indoor coil temperature falls below 29°F (-2°C) to prevent coil freeze-up. Switches reset when indoor coil temperature reaches 58°F (15°C).

3 - Crankcase Heater (HR1, HR2)

Compressors have belly band compressor oil heaters which must be on 24 hours before running compressors. Energize by setting thermostat so that there is no cooling demand, to prevent compressor from cycling, and apply power to unit.

4 - Defrost Switches (S6, S9)

Defrost switches close to initiate defrost when liquid line temperature falls to 35°F (1.7°C). The defrost switch is located on the liquid line between the outdoor expansion valve and the distributor

5 - Defrost Termination Switches (S46, S104)

Defrost pressure switches open to terminate defrost when vapor (discharge pressure during cooling and defrost) pressure reaches 450 psig (3103 kPa).

6 - Defrost Controls (CMC1)

Defrost is liquid line temperature initiated and operates for 14 minutes unless terminated by vapor line pressure drop.

When the liquid line temperature drops below 35°F, the defrost switch closes and signals the **defrost control** that a defrost cycle is needed. If the defrost switch is still closed after 60 minutes (default), a defrost cycle begins and operates for 14 minutes. The defrost pressure switch can terminate the defrost cycle before the 14 minutes elapses if vapor pressure reaches 450 \pm 10 psi.

Electric heat is energized during defrost to maintain discharge air temperature.

Defrost Control Board

The defrost thermostat, defrost pressure switch and the defrost control work together to ensure that the heat pump outdoor coil does not ice excessively during the heating mode.

Compressor Accumulated Run-Time Interval

The defrost control will not energize a defrost cycle unless the unit has been operating in heating mode for an accumulated 60 minutes (default) on 100269-02 boards; 90 minutes (default) on 100269-07 boards. The run time interval can be changed by moving the jumper on the CMC board timing pins. See FIGURE 14.

The defrost interval can be adjusted to 30, 60, or 90 minutes. The defrost timing jumper is factory-installed to provide a 60-minute defrost interval. If the timing selector jumper is not in place, the control defaults to a 90-minute defrost interval.

Defrost Test Option

A TEST option is provided for troubleshooting. The TEST mode may be started any time the unit is in the heating mode and the defrost thermostat is closed or jumpered. If the timing jumper is in the TEST position at power-up, the

defrost control will ignore the test pins. When the jumper is placed across the TEST pins for two seconds, the control will enter the defrost mode. If the jumper is removed before an additional 5-second period has elapsed (7 seconds total), the unit will remain in defrost mode until the defrost pressure switch opens or 14 minutes have passed. If the jumper is not removed until after the additional 5-second period has elapsed, the defrost will terminate and the test option will not function again until the jumper is removed and re-applied.

Diagnostic LEDs

The defrost board uses two LEDs for diagnostics. The LEDs flash a sequence according to the condition.

TABLE 10

Defrost Control Board Diagnostic LED		
Indicates	LED 1	LED 2
Normal operation / power to board	Synchronized Flash with LED 2	Synchronized Flash with LED 1
Board failure / no power	Off	Off
Board failure	On	On
Pressure switch open	Flash	On

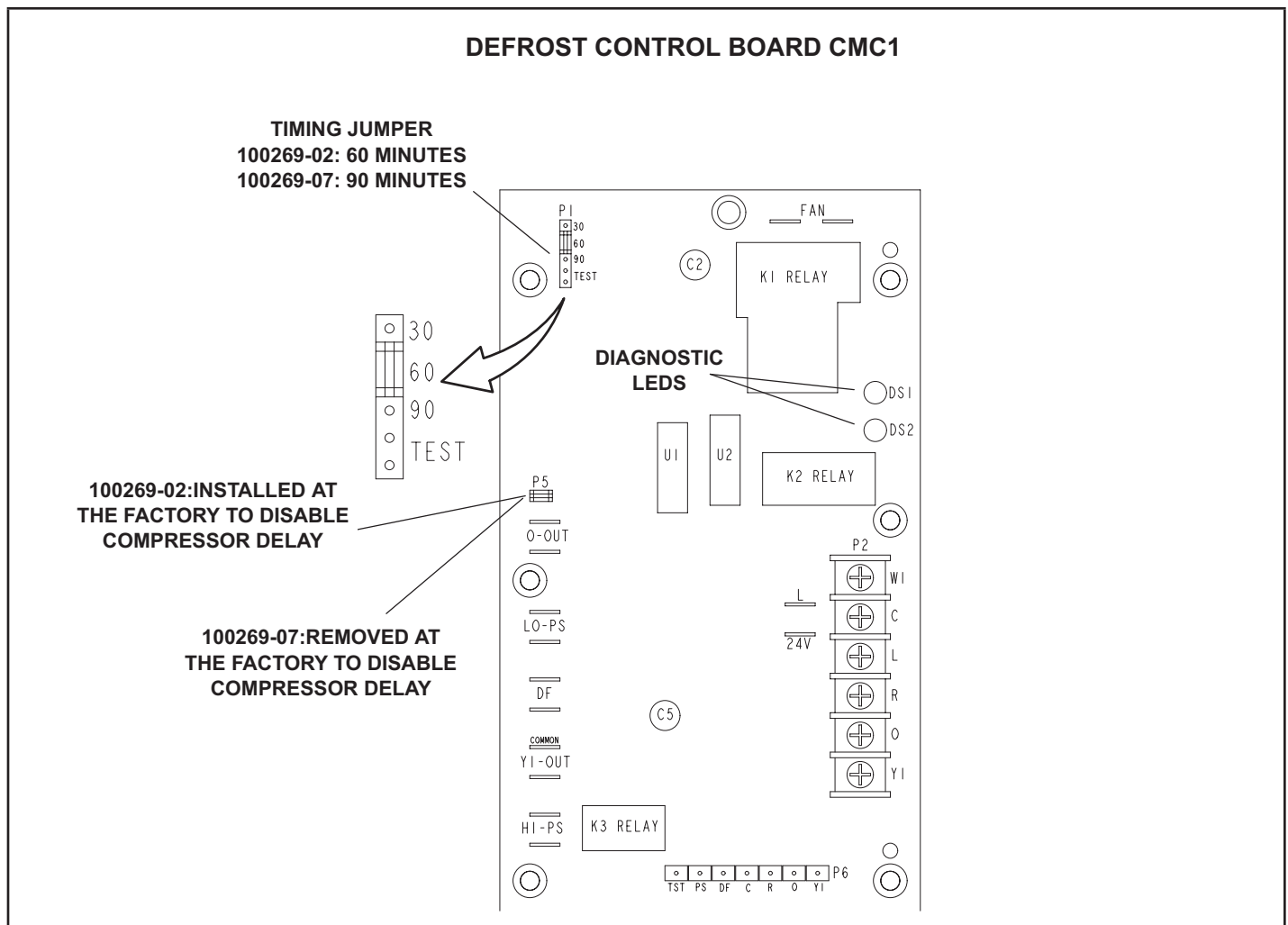

FIGURE 15

Supply Air Inverter Start-Up

A-General

Units provide three blower speeds. The blower will operate at lower speeds when cooling demand is low and higher speeds when cooling demand is high. This results in lower energy consumption. See TABLE 12 for detailed unit operation.

Inverter-driven blowers will operate at high speed during ventilation (blower “G” only signal) but can be adjusted to operate at low speed.

Low speed is approximately 66% of the full speed RPM and medium speed is 75% of the full speed RPM.

B-Set Maximum Blower CFM

- 1 - Initiate a blower (G) only signal from the room thermostat or control system.
- 2 - Adjust the blower pulley to deliver the full (high speed) CFM in the typical manner. See Determining Unit CFM in the Blower Operation and Adjustment section.

NOTE - The following sections detail how to set ventilation speeds and minimum damper positions on units with standard economizers. On units with high performance economizers, ventilation speeds and three separate damper positions must be programmed via the economizer controller display. See economizer installation instructions and high performance economizer application guide provided with the unit for further instructions.

C-Set Blower Speed During Ventilation (Units With Standard Economizers Only)

To save energy during ventilation, the blower speed can be set to low. This is accomplished by changing the ventilation speed switch on the VFD control board to “LO”. See FIGURE 16.

NOTE - On units equipped with a standard economizer, set damper minimum position as shown in the next section. After adjusting the low speed minimum position, the ventilation speed switch will be in the “LO” position.

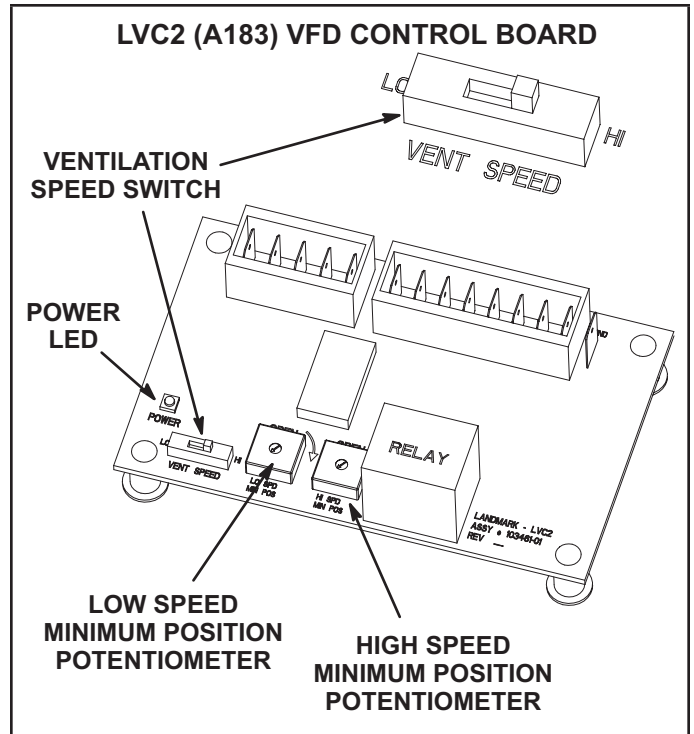

FIGURE 16

D-Set Damper Minimum Position (Units With Standard Economizers Only)

To maintain required minimum ventilation air volumes when the unit is in the occupied mode, two minimum damper positions must be set. A high and a low speed potentiometer are provided on the VFD control board to adjust minimum damper position. See figure 16. The low speed minimum damper position is used for both low and medium blower speeds as standard economizers only offer 2 damper positions.

Set High Speed Minimum Position

- 1 - Initiate a blower (G) only AND occupied demand from the room thermostat or control system.
- 2 - Set the ventilation speed switch on the VFD control board to “HI”.
- 3 - Rotate the high speed potentiometer on the VFD control board to set the high speed minimum damper position.
- 4 - Measure the intake air CFM. If the CFM is lower than the design specified CFM for ventilation air, use the potentiometer to increase the damper percent open. If the CFM is higher than specified, decrease the damper percent open.

NOTE - Intake air CFM can also be determined using the outdoor air temperature, return air temperature and mixed air temperature. Refer to the economizer or outdoor air damper installation instructions.

Set Low Speed Minimum Position

- 1 - Initiate a blower (G) only AND occupied demand from the room thermostat or control system.
- 2 - Set the ventilation speed switch on the VFD control board to "LO".
- 3 - Rotate the low speed potentiometer on the VFD control board to set the low speed minimum damper position.
- 4 - Measure the intake air CFM. If the CFM is lower than the design specified CFM for ventilation air, use the potentiometer to increase the damper percent open. If the CFM is higher than specified, decrease the damper percent open.

NOTE - Intake air CFM can also be determined using the outdoor air temperature, return air temperature and mixed air temperature. Refer to the economizer or outdoor air damper installation instructions.

Troubleshoot LVC2 Board (A183)

Refer to wiring diagram sections B (unit), C (control) and D (economizer) located on inside of unit panels.

- 1 - Inspect the LVC2 for damaged components. Replace the LVC2 if damaged components are found.
- 2 - Check all wire connections to LVC2; secure if loose.
- 3 - Check for 24VAC signal at the thermostat blower input (G to GND terminal). See FIGURE 17.

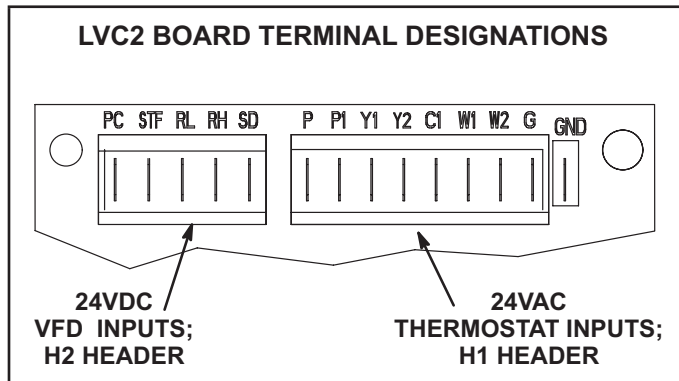

FIGURE 17

- 4 - If there is no thermostat signal, troubleshoot back toward the thermostat.
- 5 - Check the power LED on the board. See FIGURE 16.
- 6 - If the power LED is not on, check voltage between LVC2 terminals PC (H2-1) and SD (H2-5). Voltage should read 24VDC.
- 7 - If voltage does not read 24VDC, disconnect the H2 header from the LVC2 VFD inputs terminal block (to make sure the LVC2 is not shorting 24VDC supply from the inverter). Measure the voltage between the end terminals on the H2 header. If 24VDC is present, replace the LVC2 board. If no voltage is read, troubleshoot the VFD.
- 8 - When LVC2 24VAC thermostat blower (G) input and 24VDC power are present, check the LVC2 low and high speed outputs. The LVC2 uses inverse logic to enable the blower; 1VDC will be read at the enabled blower speed terminal. See TABLE 11.
- 9 - If all inputs are correct and the unit still does not operate as intended, replace LVC2 board.

TABLE 11
LVC2 BOARD BLOWER OUTPUTS

Output Terminals	Voltage	Blower Operation
RL-SD	1VDC	Low Speed
RH-SD	24VDC	
RL-SD	24VDC	High Speed
RH-SD	1VDC	
RL-SD	1VDC	Illegal State (replace board)
RH-SD	1VDC	
RL-SD	24VDC	Blower Off (replace board)
RH-SD	24VDC	

**TABLE 12
UNIT OPERATION**

T'stat DDC	Defrost	OAS	Compressor			Aux. Heat	Blower Speeds					OD Fans	Economo.		Reheat Valves
			1-Low	1-Hi	2		Vent	Cool C1	Cool C2	Cool C3	Heat (Hi)		1/2	Occupied	
G							X					Off/Off	Min (Vent)	Closed	Off
Y1		No	On	Off	Off			X				On/Off	Min Lo	Closed	On
Y1 + Y2		No	On	Off	On				X			On/On	Min Lo	Closed	On
Y1 + Y2 +Y3		No	On	On	On					X		On/On	Min Hi	Closed	On
Y1		Yes	Off	Off	Off					X		Off/Off	Mod	Mod	Off
Y1 + Y2		Yes	On	Off	Off			X				On/Off	Mod	Mod	On
Y1 + Y2 +Y3		Yes	On	On	Off					X		On/Off	Mod	Mod	On
W1	No		On	On	On	Off					X	On/On	Min Hi	Closed	Off
W1 + W2	No		On	On	On	On					X	On/On	Min Hi	Closed	Off
W1	Yes		On	On	On	On					X	Off/Off	Min Hi	Closed	On
W1 + W2	Yes		On	On	On	On					X	Off/Off	Min Hi	Closed	On

Service

The unit should be inspected once a year by a qualified service technician.

⚠ CAUTION

Label all wires prior to disconnection when servicing controls. Wiring errors can cause improper and dangerous operation. Verify proper operation after servicing.

A-Lubrication

All motors are lubricated at the factory. No further lubrication is required.

B-Filters

Units are equipped with four 20 X 25 X 2" filters. Filters should be checked monthly and replaced when necessary with filters of like kind and size. Take note of air flow direction marking on filter frame when reinstalling filters. See FIGURE 18.

NOTE - Filters must be U.L.C. certified or equivalent for use in Canada.

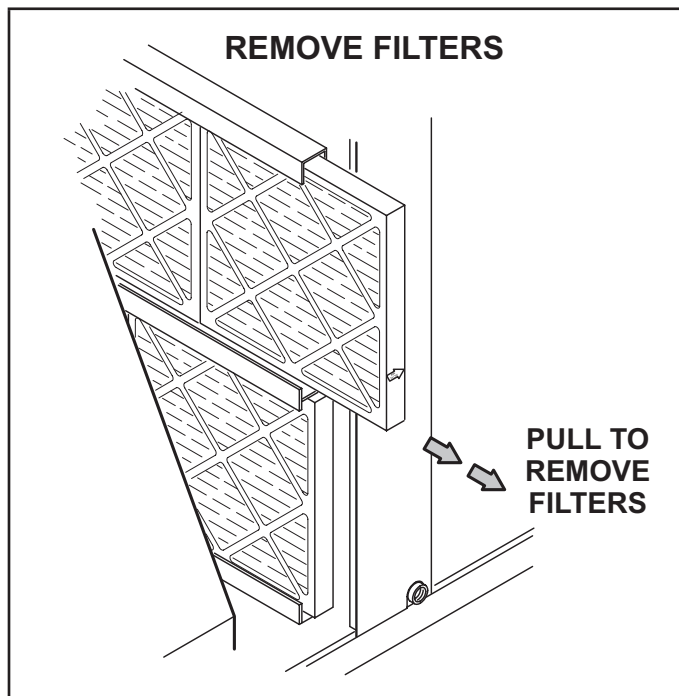

FIGURE 18

C-Supply Air Blower Wheel

Annually inspect supply air blower wheel for accumulated dirt or dust. Turn off power before attempting to remove access panel or to clean blower wheel.

D-Indoor Coil

Inspect and clean coil at beginning of each cooling and heating season. Clean using mild detergent or commercial coil cleanser. Flush coil and condensate drain with water taking care not to get insulation, filters and return air ducts wet.

E-Outdoor Coil

Clean condenser coil annually with detergent or commercial coil cleaner and inspect monthly during the cooling season.

Condenser coils are made of two formed slabs. Dirt and debris may become trapped between the slabs. To clean between slabs, carefully separate coil slabs and wash them thoroughly. See FIGURE 19. Flush coils with water following cleaning.

F-Filter Drier

The unit is equipped with a bi-flow filter drier. If replacement is necessary, order another of like design.

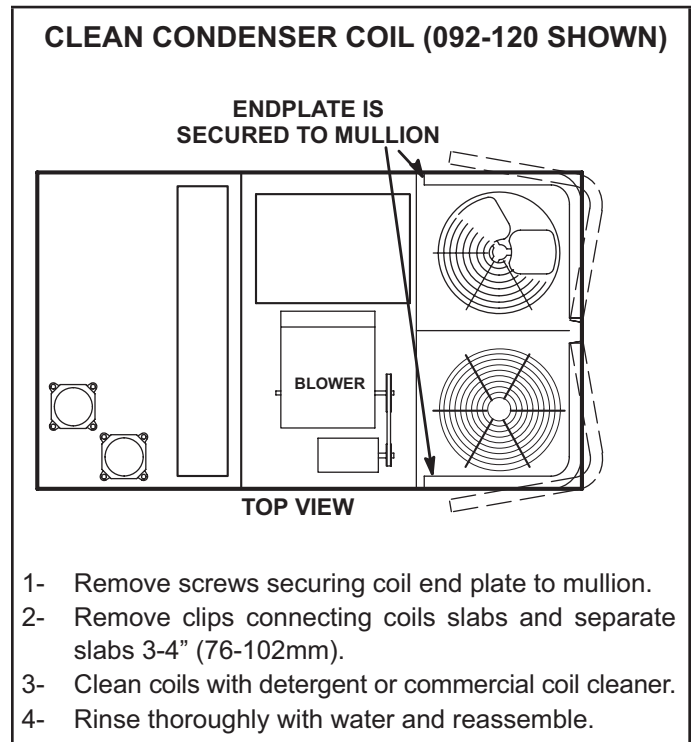

FIGURE 19

START-UP REPORT

Job Name: _____
 Store No. _____ Start-Up Date: _____
 Address: _____
 City: _____ State: _____
 Start-Up Contractor: _____
 Technician: _____
 Model No.: _____
 Serial No.: _____
 RTU No.: _____ Catalog No.: _____

Inspections and Checks			
Damage?	Yes	No	R22 <input type="checkbox"/> R410A <input type="checkbox"/>
If yes, reported to: _____			
Verify factory and field-installed accessories.			
Check electrical connections. Tighten if necessary.			
Supply voltage: L1-L2 _____ L1-L3 _____ L2-L3 _____			
If unit contains a 208-230/240 volt transformer:			
Check primary transformer tap <input type="checkbox"/>			
Transformer secondary voltage: _____			

Cooling Checks												
Compressor Rotation <input type="checkbox"/> Ambient Temp. _____ Return Air Temp. _____ Supply Air Temp. _____												
	Compressor Amps			Compressor Volts			Pressures		Condenser Fan Amps			CC Heater Amps
	L1	L2	L3	L1-L2	L1-L3	L2-L3	Disch.	Suct.	L1	L2	L3	L1
1												
2												
3												
4												

Blower Checks			
Pulley/Belt Alignment <input type="checkbox"/>	Blower Rotation <input type="checkbox"/>		
Set Screws Tight <input type="checkbox"/>	Belt Tension <input type="checkbox"/>		
Nameplate Amps: _____		Volts: _____	
Motor	Amps	Volts	
	L1 _____	L1-L2 _____	
	L2 _____	L1-L3 _____	
	L3 _____	L2-L3 _____	

Heating Checks - Electric							
Return Air Temp.: _____ Supply Air Temp.: _____							
Limits Operate: <input type="checkbox"/>							
	Amps						
	L1	L2	L3		L1	L2	L3
1				10			
2				11			
3				12			
4				13			
5				14			
6				15			
7				16			
8				17			
9				18			

Heating Checks - Gas		
Fuel type: Nat. <input type="checkbox"/> LP <input type="checkbox"/> Inlet Pressure: _____ in. w.c.		
Return Air Temp.: _____ Supply Air Temp.: _____		
Altitude: _____ Primary Limits Operate: <input type="checkbox"/>		
CO ₂ %: _____		
Gas Valve	Manifold Pressure	
	Low Fire	High Fire
GV1		
GV2		

Accessory Checks	
Power Exhaust Amps	
1 _____	2 _____ None <input type="checkbox"/>
Economizer Operation	
Min. Pos. <input type="checkbox"/>	Motor travel full open/close <input type="checkbox"/>

Control Type