

507915-03
4/2024
Supersedes 10/2023

LOW AMBIENT KIT

**INSTALLATION INSTRUCTIONS FOR LOW AMBIENT KIT (23V25; 619589-09)
USED ON KGC/KCC240 PACKAGED ROOFTOP UNITS**

Shipping and Packing List**Package 1 of 1 contains:**

- 1- Head pressure control (A190)
- 1- Temperature switch bracket
- 1- Wiring harness - A190 to K254
- 1- Bag assembly containing:
 - 1-Pressure transducer (A188)
 - 1-Temperature switch (S201)
 - 10-Wire ties
 - 1-Wiring diagram
 - 2-Screws, #8-32 X 1/2 TFS
 - 2-Screws, #8-32 X 1-1/4 TFS

⚠ CAUTION

As with any mechanical equipment, contact with sharp sheet metal edges can result in personal injury. Take care while handling this equipment and wear gloves and protective clothing.

Application

This kit allows low ambient operation to 0°F (-17.8°C) unless otherwise noted in product specifications.

Operation

When ambient temperature drops below 55°F (adjustable), S201 temperature switch opens to de-energize K10 relay coil. Condenser fans 1 & 3 are de-energized.

Liquid line pressure transducer A188 converts the pressure to an analog signal which is sent to the head pressure control (A190). The head pressure control provides a variable output which slows Condenser Fan 2 & 4 operation at lower ambient temperatures.

⚠ WARNING

Improper installation, adjustment, alteration, service or maintenance can cause property damage, personal injury or loss of life. Installation and service must be performed by a licensed professional installer (or equivalent), service agency or the gas supplier.

Installation

- 1 - Disconnect all power to unit and open access panels.
- 2 - Install the head pressure control (A190) in the control
- 3 - Install the temperature switch mounting bracket onto the mullion. Align the bracket with the 4th screw from the top of the unit; secure with provided screw. See FIGURE 1.
- 4 - Install the temperature switch onto the bracket.
- 5 - Using the ICM Omni App, set the head pressure controller as follows:
 - Probe Type: Pressure
 - Setpoint: 355 psig
 - Hard Start: 0.1s
 - Minimum Voltage Output: 32%
- 6 - Install the pressure transducer on compressor 2. liquid line pressure tap as shown in FIGURE 2.

⚠ WARNING

To prevent serious injury or death:

- 1- Lock-out/tag-out before performing maintenance.
- 2- If system power is required (e.g., smoke detector maintenance), disable power to blower, remove fan belt where applicable, and ensure all controllers and thermostats are set to the "OFF" position before performing maintenance.
- 3- Always keep hands, hair, clothing, jewelry, tools, etc., away from moving parts.



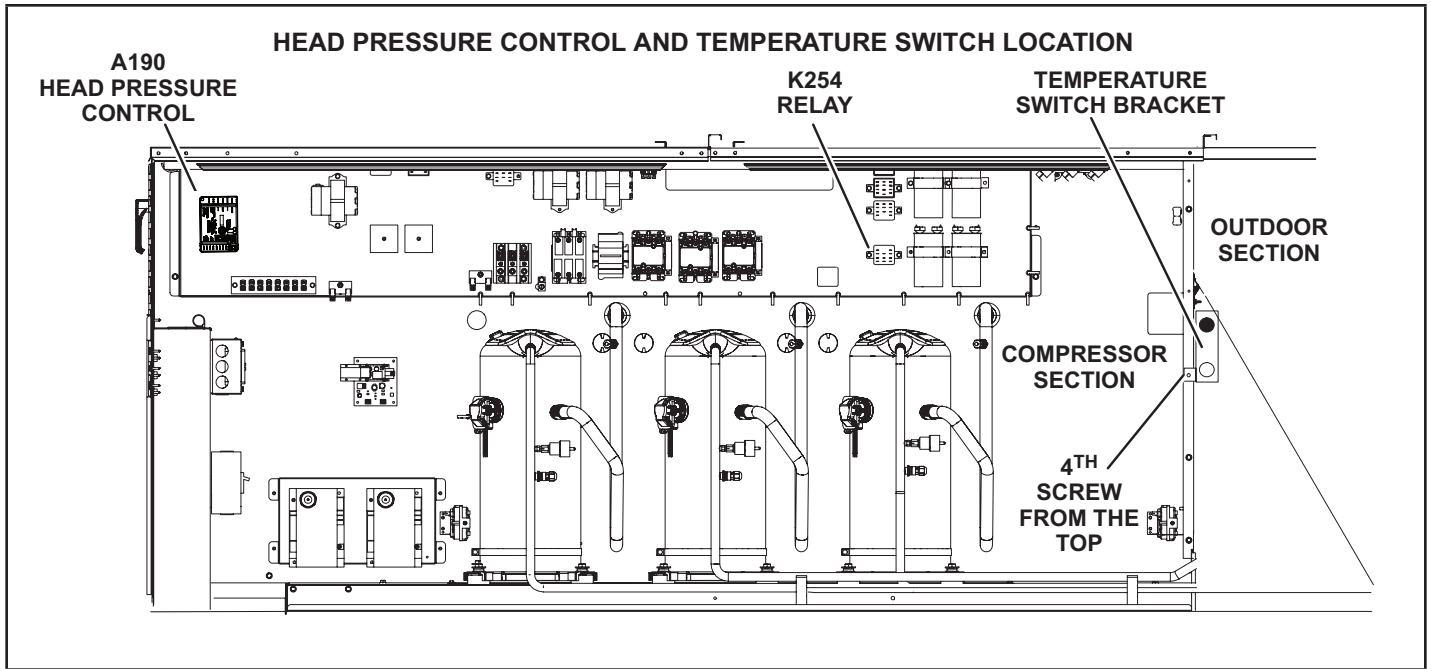

FIGURE 1

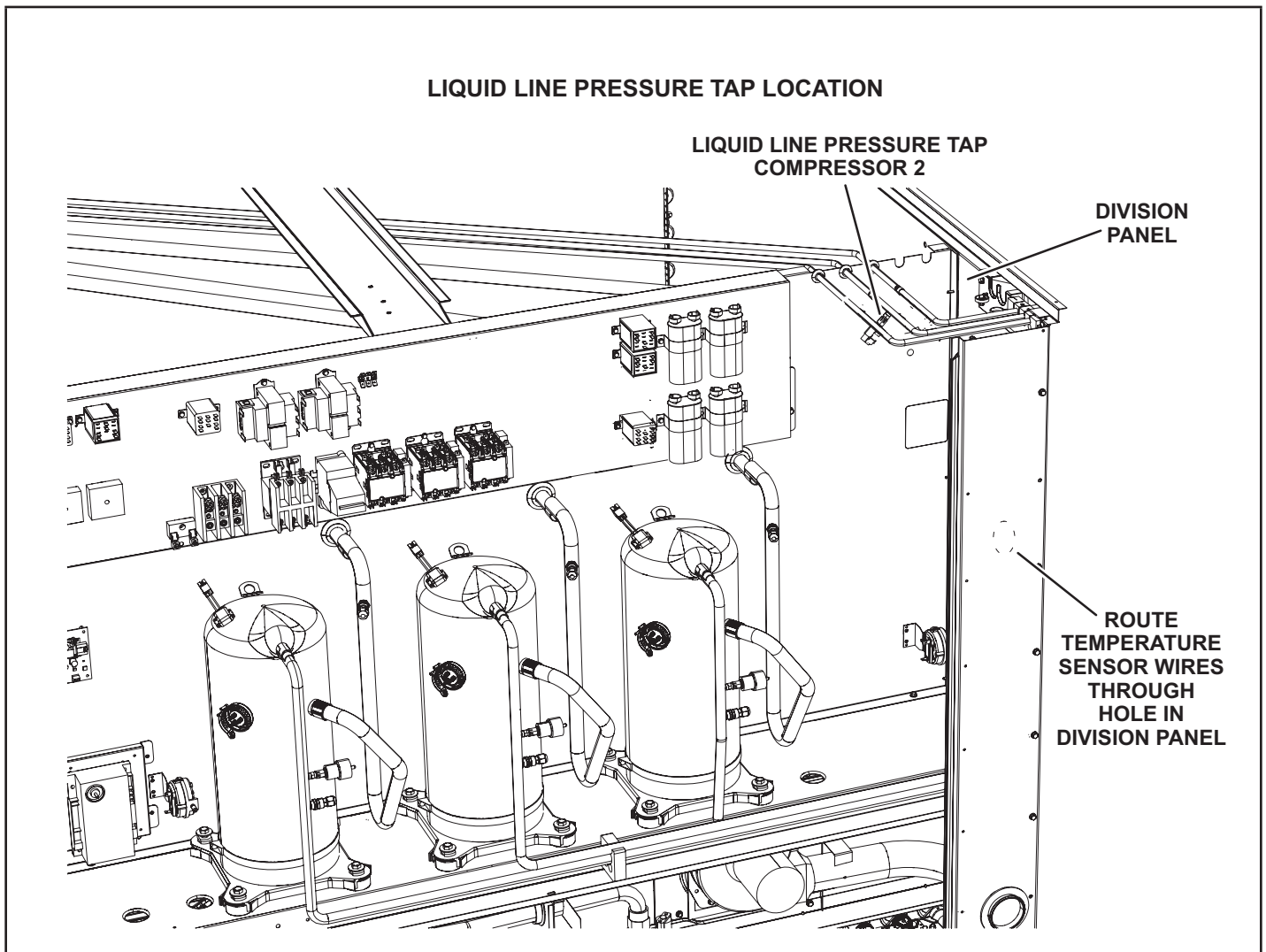

FIGURE 2

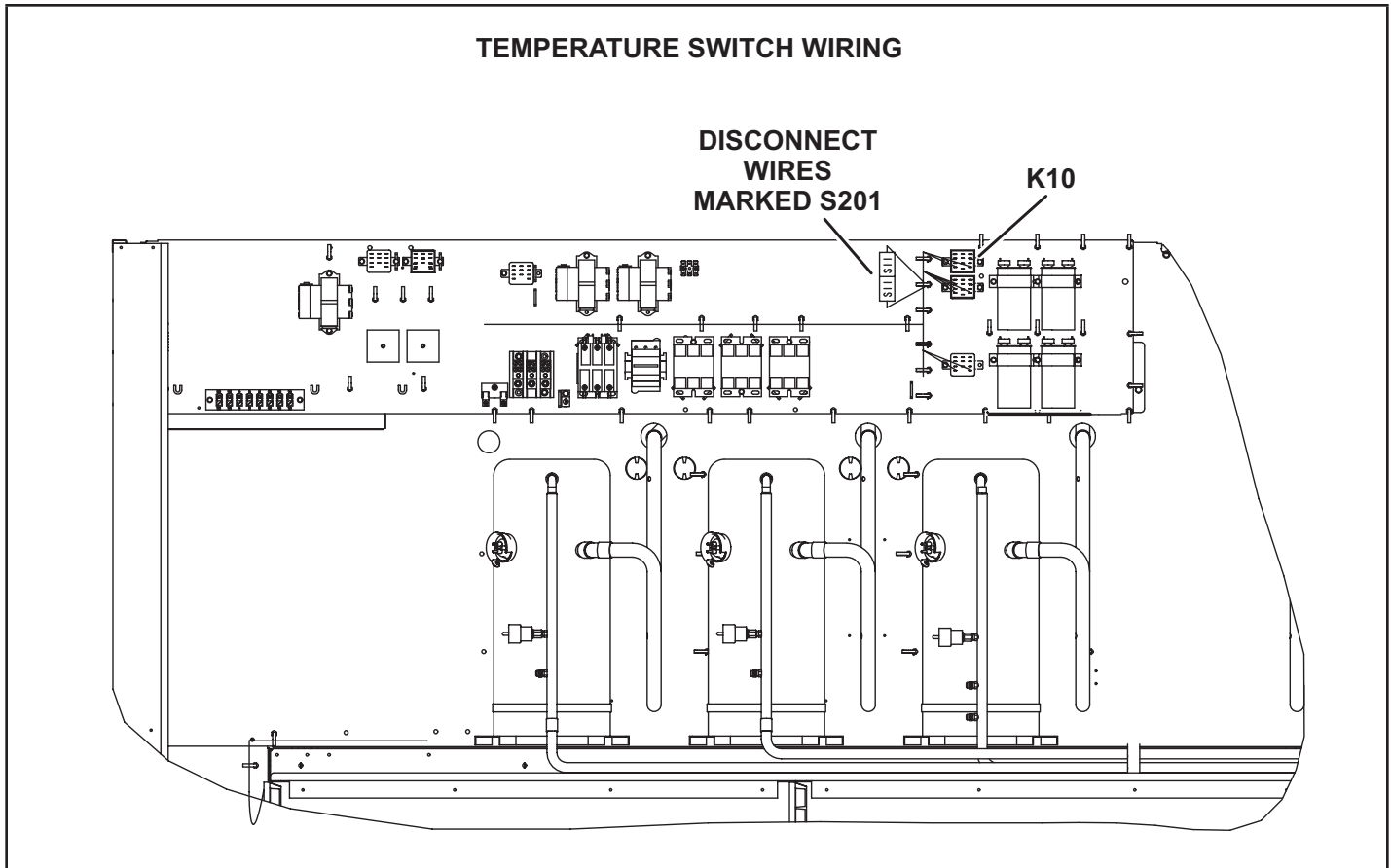

FIGURE 3

Temperature Switch Wire Connections

- 1 - Route temperature switch wires through the division panel between the compressor and outdoor coil sections. See FIGURE 2.
- 2 - Disconnect male and female terminals from wires marked "S201" near K10 relay. See FIGURE 3.
- 3 - Make wiring connections as shown in FIGURE 4.

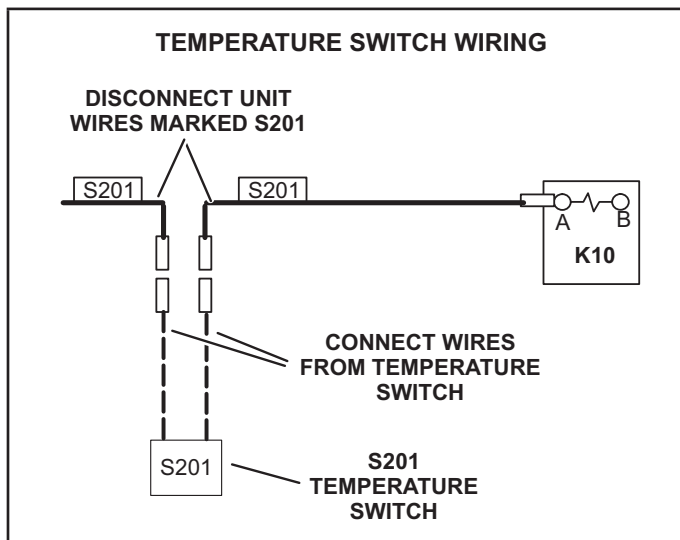

FIGURE 4

Low Voltage Wire Connections

Use the pressure transducer, provided in this kit, to make wire connections as shown in FIGURE 5.

High Voltage Wire Connections

- 1 - Disconnect factory wires to K254 terminals 4 & 6. Reconnect these wires to the kit harness as shown in FIGURE 6.
- 2 - Connect the harness wire labeled "A190-L1" to the 120 - 600 VAC terminal.
- 3 - Make the rest of the K254 harness connections as shown in FIGURE 6. Refer to the diagram in FIGURE 7.
- 4 - Make sure all connections are secure.
- 5 - Bundle wiring and use wire ties to route wiring away from sharp edges.
- 6 - Place the wiring diagram provided in this kit on the inside of the control door.
- 7 - Close unit panels and restore power.

PRESSURE TRANSDUCER WIRING

A190 HEAD PRESSURE CONTROL

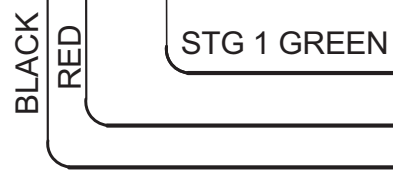
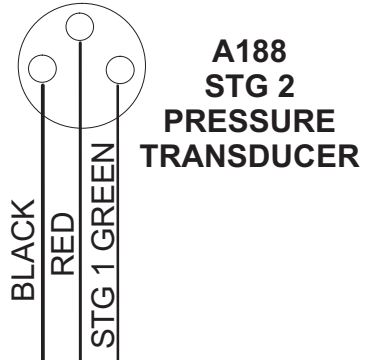
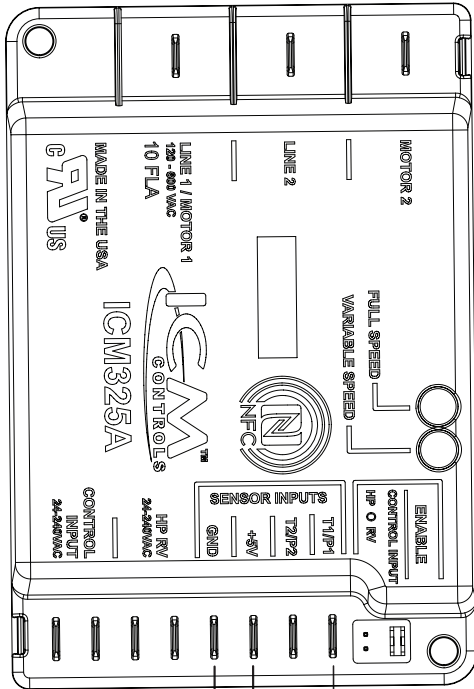

FIGURE 5

K254 HARNESS WIRING

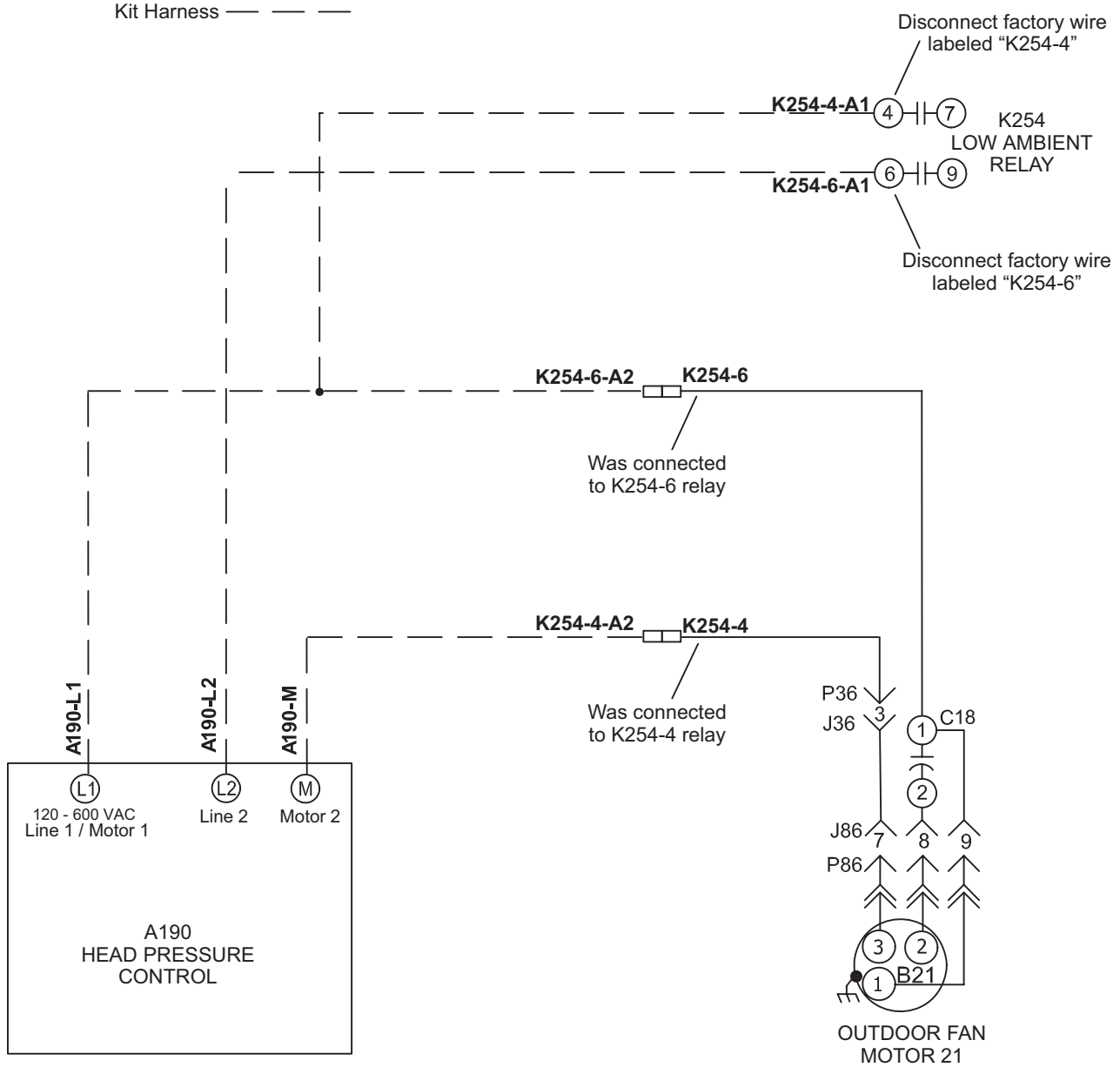
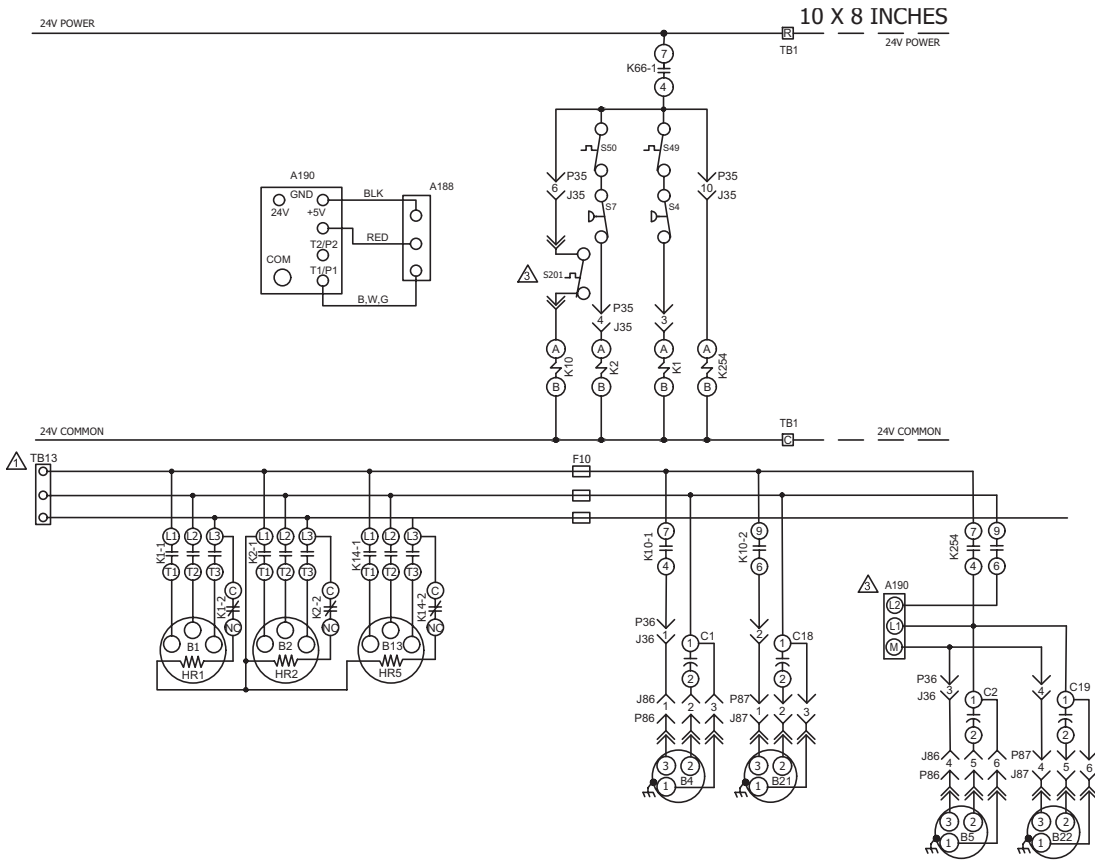

FIGURE 6



KEY	COMPONENT
A188	PRESSURE TRANSDUCER, COMP 2
A190	PRESSURE CONTROLLER, COMP 2, LOW AMBIENT KIT
B1	COMPRESSOR 1
B2	COMPRESSOR 2
B4	MOTOR, OUTDOOR FAN 1
B5	MOTOR, OUTDOOR FAN 2
B13	COMPRESSOR 3
B21	MOTOR, OUTDOOR FAN 3
B22	MOTOR, OUTDOOR FAN 4
C1	CAPACITOR, OUTDOOR FAN 1
C2	CAPACITOR, OUTDOOR FAN 2
C18	CAPACITOR, OUTDOOR FAN 3
C19	CAPACITOR, OUTDOOR FAN 4
J/P 35	JACK/ PLUG, RUN TEST
J/P 36	JACK/ PLUG, RUN TEST OD FANS
HR1	HEATER, COMPRESSOR 1
HR2	HEATER, COMPRESSOR 2
HR5	HEATER, COMPRESSOR 3
K1-1,2	CONTACTOR, COMPRESSOR 1
K2-1,2	CONTACTOR, COMPRESSOR 2
K10-1, 2	RELAY, OUTDOOR FANS 1, 2
K14-1,2	CONTACTOR, COMPRESSOR 3
K66-1	RELAY, STAGE COOL 1
K254	RELAY, LOW AMBIENT KIT FAN 3

S4	SWITCH, LIMIT HI PRESS COMP 1
S7	SWITCH, LIMIT HI PRESS COMP 2
S49	SWITCH, FREEZESTAT COMP 1
S50	SWITCH, FREEZESTAT COMP 2
S201	SWITCH, LOW AMBIENT TEMP SENSOR 1
TB1	TERMINAL STRIP, 24V
TB13	TERMINAL STRIP, POWER DISTRIBUTION

- ⚠ REFER TO UNIT RATING PLATE FOR MINIMUM CIRCUIT AMPACITY AND MAXIMUM OVERCURRENT PROTECTION
- ⚠ F10 USED ON Y-VOLT UNITS ONLY
- ⚠ REFER TO INSTRUCTION SHEETS FOR LOW AMBIENT HARNESS INSTALLATION PROCEDURE

WARNING-ELECTRIC SHOCK HAZARD CAN CAUSE INJURY OR DEATH. UNIT MUST BE GROUNDED IN ACCORDANCE WITH NATIONAL AND LOCAL CODES

FOR USE WITH COPPER CONDUCTORS ONLY

DISCONNECT ALL POWER BEFORE SERVICING

IF ANY WIRE IN THIS APPLIANCE IS REPLACED, IT MUST BE REPLACED WITH WIRE OF LIKE SIZE, RATING, INSULATION THICKNESS AND TERMINATION

— DENOTES OPTIONAL COMPONENTS
 — LIVE VOLTAGE FIELD INSTALLED

2024/04		WIRING DIAGRAM	04/24
		538041-03	
COOLING - MSAV			
KG/KC C-BOX - 240S - G, J, Y VOLT LOW AMBIENT KIT			
SECTION B			REV. 2
Supersedes	New Form No.		
538041-02	538041-03		
© Lennox Commercial			

FIGURE 7