

KEY LIST		
LOCATION	COMPONENT DESCRIPTION	
CC05/08	A96	CONTROL INVERTER, BLOWER
BB09	AM1, AM2	AIR MONITOR, SUPPLY/RETURN, IAQ-TVOC
FF/GG/JJ10	B1, B2, B13	COMPRESSOR 1, 2, 3
DD10	B3	MOTOR, BLOWER
KK10, PP01/NN10	B4, B5	MOTOR, OUTDOOR FAN 1, 2
LL10, PP02/NN10	B21, B22	MOTOR, OUTDOOR FAN 3, 4
QQ09	B10, B11	MOTOR, EXHAUST FAN 1, 2
KK09	C1	CAPACITOR, OUTDOOR FAN 1
LL09	C18	CAPACITOR, OUTDOOR FAN 3
QQ09	C6, C8	CAPACITOR, EXHAUST FAN 1, 2
LL05	F6	FUSE, EXHAUST FAN
LL07	F10	FUSE, COMPONENT
LL08	F57	FUSE, T5 TRANSFORMER PRIMARY
FF/GG/JJ10	HR1, HR2, HR5	HEATER, COMPRESSOR 1, 2, 3
FF05,06,08,SS07	K1	CONTACTOR, COMPRESSOR 1
GG/JJ05,06,08	K2, K14	CONTACTOR, COMPRESSOR 2, 3
DD05/EE08	K3	CONTACTOR, BLOWER
LL05/KK09	K10	RELAY, OUTDOOR FAN 1
MM05/LL09	K149	RELAY, OUTDOOR FAN 3
QQ07	K65, K231	RELAY, EXHAUST FAN 1, 2
DD08/08	K202	CONTACTOR, INVERTER
EE06	K203	RELAY, INVERTER CONTROL
AA02	L14, L30	VALVE, SOLENOID, REHEAT COIL 1, 2
GG01	RT6	SENSOR, A55 DISCHARGE (IMC)
DD01	RT17	SENSOR, OUTSIDE AIR TEMP
GG02,MM01	RT46, RT47, RT50	SENSOR, SAT. SUCT TEMP., COMP 1, 2, 3
DD02, JJ01	RT48, RT49, RT52	SENSOR, SAT. LIQUID TEMP., COMP 1, 2, 3
BB01/02, GG02	S4, S7, S28	LIMIT, HI PRESS. SWITCH, COMP 1, 2, 3
EE09	S42	OVERLOAD, RELAY, BLOWER MOTOR
BB02, GG03	S87, S88, S98	SWITCH, LOW PRESS., COMP. 1, 2, 3
AA06	T1	TRANSFORMER, CONTROL
MM08	T5	TRANSFORMER, OUTDOOR FAN MOTOR
BB06	T18	TRANSFORMER, CONTACTOR
AA10	T49	TRANSFORMER, UVC-LIGHT POWER
AA07	TB13	TERMINAL STRIP, POWER DISTRIBUTION

- NOTES**
- 1 ONLY ON UNITS WITH HUMIDITROL OPTION
  - 2 FOR REMOTE LOCATION OF RT6, ADD THE EXTENSION HARNESS
  - 3 S42 USED ON UNITS WITH 10HP MOTORS
  - 4 P431 MAY ONLY BE USED WHEN BLOWER IS CONFIGURED FOR CAV OPERATION
- ▲ DENOTES OPTIONAL COMPONENTS AND WIRING

**WARNING**  
DISCONNECT ALL POWER BEFORE SERVICING.  
ELECTRIC SHOCK HAZARD. CAN CAUSE INJURY OR DEATH. UNIT MUST BE GROUNDED IN ACCORDANCE WITH NATIONAL AND LOCAL CODES.  
FOR USE WITH COPPER CONDUCTORS ONLY. REFER TO UNIT RATING PLATE FOR MINIMUM CIRCUIT AMPACITY AND MAXIMUM OVERCURRENT PROTECTION SIZE.  
IF ANY WIRE IN THIS APPLIANCE IS REPLACED, IT MUST BE REPLACED WITH WIRE OF LIKE SIZE, RATING AND INSULATION THICKNESS.

Model: LGT, LCT 180H - G, J-VOLT  
Voltage: 460V/3~/60Hz (G), 575V/3~/60Hz (J)  
COOLING - MSAV WITH BYPASS - 3 COMPRESSORS 4 CONDENSER FANS  
Supersedes: N/A Form No: 538214-01 Rev: 1

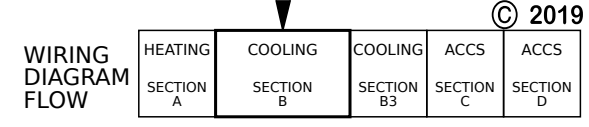

10x17 CUT SIZE

REV	EC NO.	DATE	BY	APVD	REVISION NOTE
---	CN-010356	06-20-2022	MXR6	JAL21	ORIGINATED AT PD&R CARROLLTON, TX
001	CN-010356E	07-26-2022	MXR6	JAL21	A) REVERSED HIGH VOLTAGE WIRING ON T18 TRANSFORMER.

© 2019

538214-01  
01

02

03

04

05

06

07

08

09

10

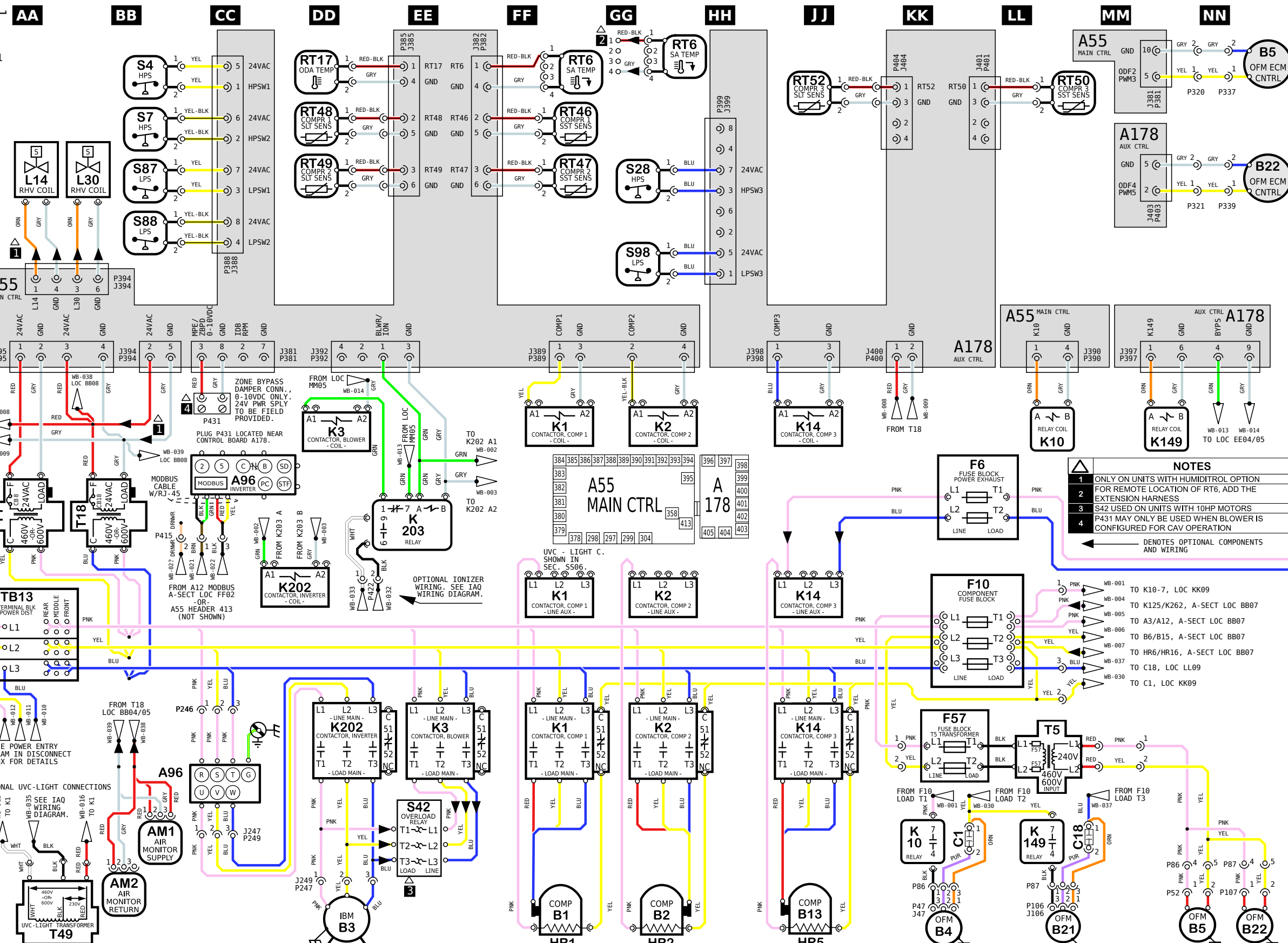

KEY LIST		
LOCATION	COMPONENT DESCRIPTION	
CC05/08	A96	CONTROL INVERTER, BLOWER
BB09	AM1, AM2	AIR MONITOR, SUPPLY/RETURN, IAQ-TVOC
FF/GG/JJ10	B1, B2, B3	COMPRESSOR 1, 2, 3
DD10	B3	MOTOR, BLOWER
KK10, PP01/NN10	B4, B5	MOTOR, OUTDOOR FAN 1, 2
LL10, PP02/NN10	B21, B22	MOTOR, OUTDOOR FAN 3, 4
QQ09	B10, B11	MOTOR, EXHAUST FAN 1, 2
KK09	C1	CAPACITOR, OUTDOOR FAN 1
LL09	C18	CAPACITOR, OUTDOOR FAN 3
QQ09	C6, C8	CAPACITOR, EXHAUST FAN 1, 2
LL05	F6	FUSE, EXHAUST FAN
LL07	F10	FUSE, COMPONENT
LL08	F57	FUSE, T5 TRANSFORMER PRIMARY
FF/GG/JJ10	HR1, HR2, HR5	HEATER, COMPRESSOR 1, 2, 3
FF05, 06, 08, SS07	K1	CONTACTOR, COMPRESSOR 1
GG/JJ05, 06, 08	K2, K14	CONTACTOR, COMPRESSOR 2, 3
DD05/EE08	K3	CONTACTOR, BLOWER
LL05/KK09	K10	RELAY, OUTDOOR FAN 1
MM05/LL09	K149	RELAY, OUTDOOR FAN 3
QQ07	K65, K231	RELAY, EXHAUST FAN 1, 2
DD08/08	K202	CONTACTOR, INVERTER
EE06	K203	RELAY, INVERTER CONTROL
AA02	L14, L30	VALVE, SOLENOID, REHEAT COIL 1, 2
GG01	RT6	SENSOR, A55 DISCHARGE (IMC)
DD01	RT17	SENSOR, OUTSIDE AIR TEMP
GG02, MM01	RT46, RT47, RT50	SENSOR, SAT. SUCT TEMP., COMP 1, 2, 3
DD02, JJ01	RT48, RT49, RT52	SENSOR, SAT. LIQUID TEMP., COMP 1, 2, 3
BB01/02, GG02	S4, S7, S28	LIMIT, HI PRESS. SWITCH, COMP 1, 2, 3
EE09	S42	OVERLOAD, RELAY, BLOWER MOTOR
BB02, GG03	S87, S88, S98	SWITCH, LOW PRESS., COMP. 1, 2, 3
AA06	T1	TRANSFORMER, CONTROL
MM08	T5	TRANSFORMER, OUTDOOR FAN MOTOR
BB06	T18	TRANSFORMER, CONTACTOR
AA10	T49	TRANSFORMER, UVC-LIGHT POWER
AA07	TB13	TERMINAL STRIP, POWER DISTRIBUTION

**NOTES**

- 1 ONLY ON UNITS WITH HUMIDITROL OPTION
- 2 FOR REMOTE LOCATION OF RT6, ADD THE EXTENSION HARNESS
- 3 S42 USED ON UNITS WITH 10HP MOTORS
- 4 P431 MAY ONLY BE USED WHEN BLOWER IS CONFIGURED FOR CAV OPERATION

▲ DENOTES OPTIONAL COMPONENTS AND WIRING

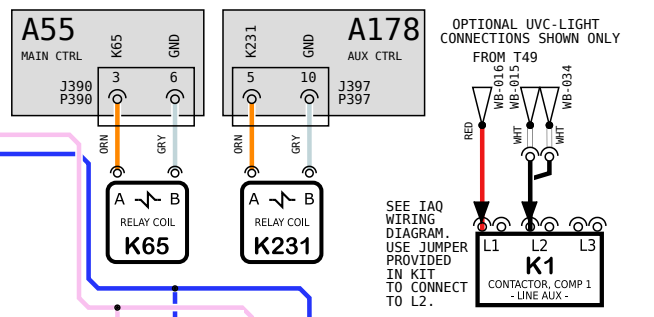

**WARNING**  
DISCONNECT ALL POWER BEFORE SERVICING.  
ELECTRIC SHOCK HAZARD. CAN CAUSE INJURY OR DEATH. UNIT MUST BE GROUNDED IN ACCORDANCE WITH NATIONAL AND LOCAL CODES.  
FOR USE WITH COPPER CONDUCTORS ONLY. REFER TO UNIT RATING PLATE FOR MINIMUM CIRCUIT AMPACITY AND MAXIMUM OVERCURRENT PROTECTION SIZE.  
IF ANY WIRE IN THIS APPLIANCE IS REPLACED, IT MUST BE REPLACED WITH WIRE OF LIKE SIZE, RATING AND INSULATION THICKNESS.

Model: LGT, LCT 180H - G, J-VOLT  
COOLING - MSAV WITH BYPASS - 3 COMPRESSORS 4 CONDENSER FANS

Voltage: 460V/3~60Hz (G), 575V/3~60Hz (J)  
Supersedes: N/A Form No: 538214-01 Rev: 1

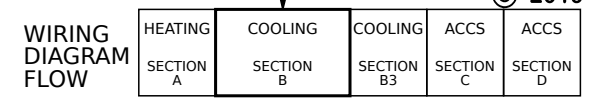

10x17  
CUT SIZE

REV	EC NO.	DATE	BY	APVD	REVISION NOTE
---	CN-010356	06-20-2022	MXR6	JAL21	ORIGINATED AT PD&R CARROLLTON, TX
001	CN-010356E	07-26-2022	MXR6	JAL21	A) REVERSED HIGH VOLTAGE WIRING ON T18 TRANSFORMER.

© 2019