

Job: _____
 Location: _____
 Schedule No.: _____
 System Designation: _____

Engineer: _____
 Architect: _____
 Location: _____
 Date: _____

Wall Hung Air Handler

For: Reference Approval Review Construction

FEATURES

- Multi-speed ECM motor
- Built in filter rack
- All aluminum coil
- Wall-hanging bracket provided
- Thermoplastic drain pan with bottom primary and secondary drain connections
- Optional heating elements of 5kW, 7.5kW, and 10kW
- Front or bottom return available
- **ONLY compatible with Lennox REAL™**

WARRANTY

- 10-year limited warranty.*See warranty for details.

SPECIFICATIONS

PERFORMANCE

Cooling Capacity ¹ (Btu/h)	36,000
External Static Pressure (in.w.c)	0.8

ELECTRICAL DATA

Power Supply (Volts/ Phase/Hertz)	208/230V-1Ph-60Hz
Min. /Max. Voltage	187/253
Minimum Circuit Ampacity	3.4
Minimum Circuit Protection	15

FAN MOTOR

Motor Type	ECM
Horsepower (HP)	1/2
Rated RPM	1050
Full Loaded Amps (FLA)	2.7

FAN BLOWER

Material	Metal
Type	Centrifugal
Diameter (in.)	10-3/4
Height (in.)	8

EVAPORATOR COIL

Type	Tube & Fin
Tube Material	Aluminum
Tube Size (in.)	9/32

SOUND POWER (dB)

	54
--	----

REFRIGERANT CONNECTION SIZE

Liquid Line Size (O.D.)	3/8
Suction Line Size (O.D.)	3/4

DIMENSIONS

Unit Dimensions (in)	Height	39-1/2
	Width	22
	Depth	19
Weight (lbs.)	Unit Weight	97
	Shipping Weight	119

FILTER SIZES (in.)

	20 x 20 x1
--	------------



NOTES

1. Cooling and Heating capacity data is rated at the following conditions:
 Cooling: 80°FDB / 67°FWB Indoor, 95°FDB
 Outdoor Heating: 70°FDB Indoor, 47°FDB / 43°FWB Outdoor.
2. Power Input values are rated at high fan speed.



NOTE – Due to Lennox' ongoing commitment to quality, Specifications, Ratings and Dimensions subject to change without notice and without incurring liability. Improper installation, adjustment, alteration, service or maintenance can cause property damage or personal injury. Installation and service must be performed by a qualified installer and servicing agency.

DIMENSIONAL DRAWINGS - INCHES (MM)

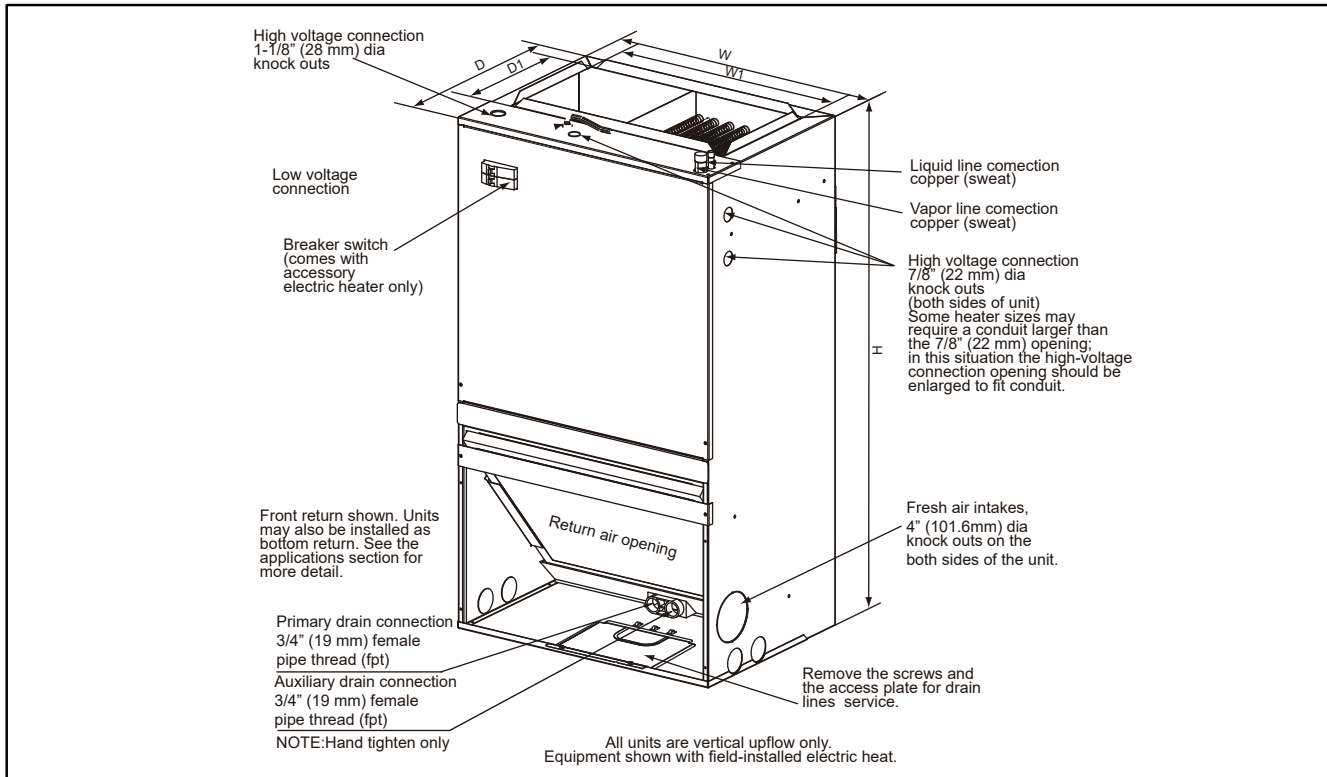

Table 1 – Dimensional Data

Model Size	Dimensions-In. (mm)					Unit Weight / Shipping Weight Lbs. (kg)
	Unit Height H	Unit Width W	Unit Width W1	Unit Depth D	Unit Depth D1	
ECM 18K/24K	36-1/2 (928)	20-1/2 (521)	17-2/5 (442)	15 (381)	9-1/2 (242)	79/ 95 (36 / 43)
ECM 30K/36K	39-1/2 (1004)	22 (559)	18-4/5 (478)	19 (483)	9-1/2 (242)	97/ 119 (44 / 54)

NOTE – Due to Lennox' ongoing commitment to quality, Specifications, Ratings and Dimensions subject to change without notice and without incurring liability. Improper installation, adjustment, alteration, service or maintenance can cause property damage or personal injury. Installation and service must be performed by a qualified installer and servicing agency.