

**INSTALLATION INSTRUCTIONS FOR OUTDOOR AIR DAMPERS
USED WITH KG/KC/KH/LG/LC/LH/LD/ZG/ZC/ZH 024-090 UNITS**

Note - Disregard shipping and packing list and installation sections when dampers are factory-installed.

⚠ CAUTION

As with any mechanical equipment, contact with sharp sheet metal edges can result in personal injury. Take care while handling this equipment and wear gloves and protective clothing.

Shipping and Packing List

Package 1 of 1 contains:

- 1- Outdoor air damper (OAD) assembly
- 1- Hood pivot bracket (15D17, 15D19)
- 1- Bag assembly containing (15D17, 15D19):
 - 1-P160/J160 jumper harness
 - 1-J39/P39 harness (15D19)
 - #10 self-drilling screws (15D19)
 - 2-Wiring diagrams (15D17)
 - 3-Wiring diagrams (15D19)
- 1- Outdoor air hood carton containing:
 - 1-Hood top (15D18, 15D20)
 - 2-Hood sides (left and right)
 - 1-Hood front filter bracket
 - 1-Filter
 - 1-Bottom filter bracket (15D17, 15D19)
 - 1-Bag assembly containing:
 - #10 sheet metal screws
 - 1-#10 - 32 X 1/2" screw (15D17, 15D19)
 - Foam tape (15D18, 15D20)

Check parts for shipping damage. Receiving party should contact last carrier immediately if shipping damage is found.

⚠ WARNING

- To prevent serious injury or death:
- 1- Lock-out/tag-out before performing maintenance.
 - 2- If system power is required (e.g., smoke detector maintenance), disable power to blower, remove fan belt where applicable, and ensure all controllers and thermostats are set to the "OFF" position before performing maintenance.
 - 3- Always keep hands, hair, clothing, jewelry, tools, etc., away from moving parts.

⚠ WARNING

Improper installation, adjustment, alteration, service or maintenance can cause property damage, personal injury or loss of life. Installation and service must be performed by a licensed professional HVAC installer or equivalent, service agency, or the gas supplier.

Application

Optional outdoor air dampers provide fresh outdoor air. See table 1 for usage.

**C1DAMP21A-1 and Z1DAMP21A-2
Motorized Dampers:**

Electro-mechanical units (KC/KG/KH/ZC/ZG/ZH) -
The damper opens to a set position when the blower is operating. To operate the damper only during the occupied time period, an optional thermostat or energy management system must be installed that provides an occupied signal to the unit's thermostat connection.

Units equipped with an M3 A55 Unit Controller (LC/LG) -
The damper opens to a set position when the blower is operating and an occupied signal is provided to the Unit Controller.

**C1DAMP11A-2 & Z1DAMP11A-2
Manual Dampers:**

Damper is manually operated; damper position is manually set at installation and remains in that position.

TABLE 1

Unit	Type	Cat. # Ass'y #
LG/LC/LH/LD 024-072 KC/KG/KH 024-090	Motorized	15D17 613924-07
LCH/LGH 036-072 KC/KG/KH 024-090	Manual	15D18 613924-08
ZC/ZG/ZH 036-060	Motorized	15D19 613924-09
ZC/ZG/ZH 036-060	Manual	15D20 613924-10

Install Motorized Damper Assembly

LG/LC/LH/LD/KG/KC/KH Units

- 4- Disconnect all power to unit.
- 5- On LG/LC/LH/LD/KG/KC/KH units equipped with factory-installed dampers, go to *Outdoor Air Hood - Motorized Damper* section.
- 6- Remove and retain five screws securing end panel to the unit. See figure 1. Remove and discard end panel.
- 7- Remove and retain two screws securing the hood top to the damper assembly (provided in kit). Remove hood top and retain. See figure 3.
- 8- Install damper assembly in unit; insert top of panel first. Secure bottom of assembly with screws retained from previous panel.

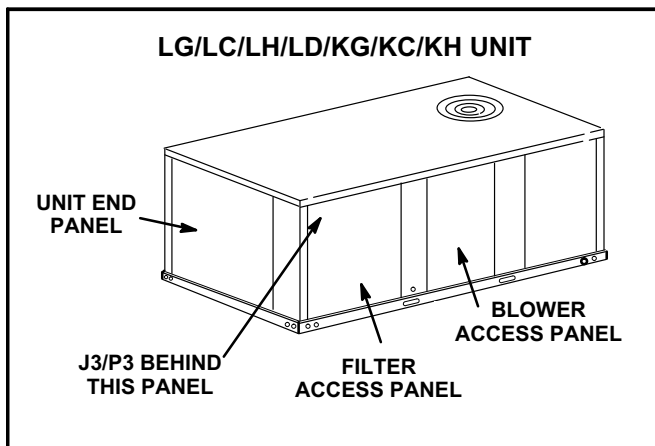

FIGURE 1

Install Motorized Damper Assembly

ZG/ZC/ZH Units

- 1- Disconnect all power to unit.
- 2- Remove and discard unit back panel. Retain screws and two door brackets which secure panel. See figure 2.
- 3- Remove filter access panel. Retain panel and screws.
- 4- Install damper assembly (provided in kit) in unit. Hold door brackets in place and secure damper assembly and brackets to unit with retained screws.
- 5- Secure the bottom of the assembly with retained screws.

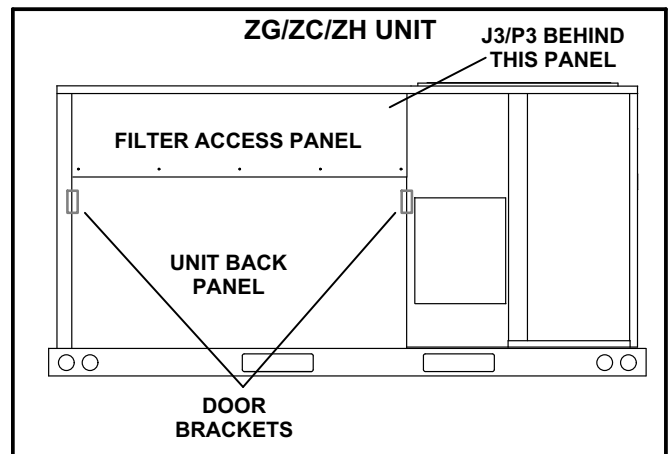

FIGURE 2

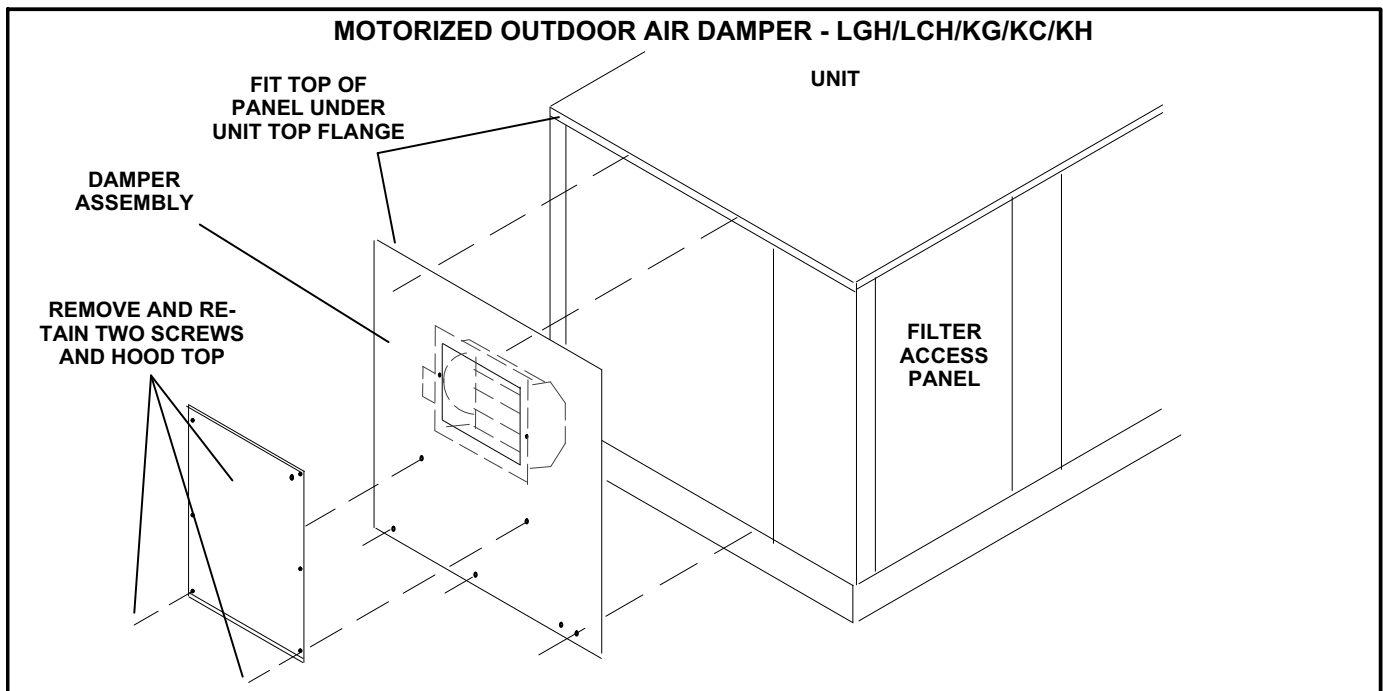

FIGURE 3

Wiring Harnesses - J/P3, P4, J/P39, J/P160

- 1- Remove the filter access panel and locate the unit connection J3/P3.
 - 2- Remove P3 jumper plug and discard.
 - 3- Locate the following harnesses provided in kit:
 KG/KC/KH Units - P160/J160
 ZG/ZC/ZH Units - P160/J160 and P39/J39
- Note - LG/LC/LH/LD units do not require kit harnesses.*
- 4- Make harness connections as shown in figure 4, 5, or 6.
 - 5- Discard unused harnesses.
 - 6- Replace the filter access panel.

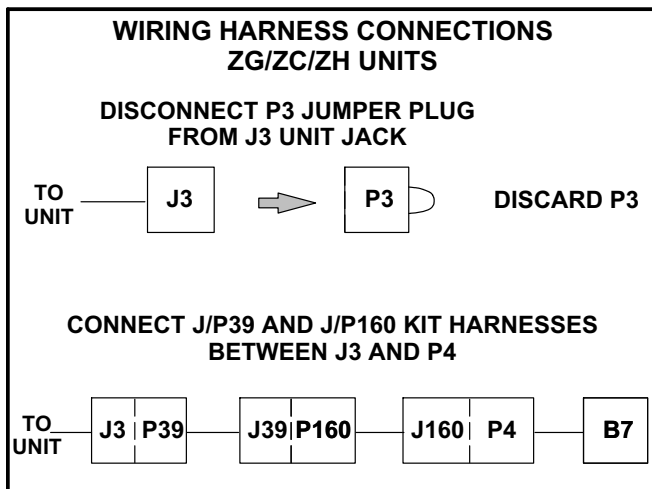

FIGURE 6

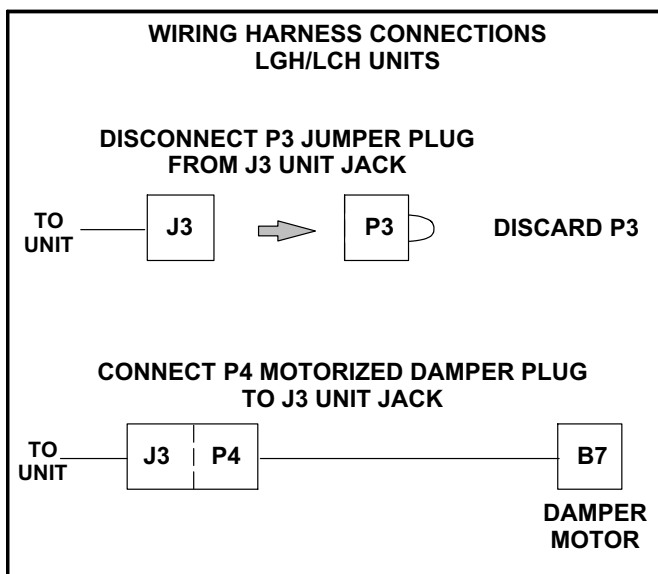

FIGURE 4

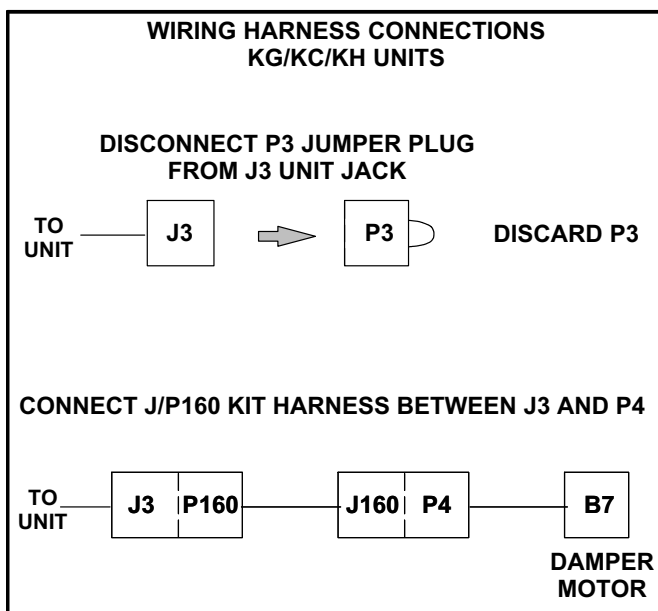

FIGURE 5

Actuator DIP Switch Setting - KG/KC/KH/ZG/ZC/ZH Units Only

- 1- Remove and retain horizontal return panel and screws.
- 2- Open the damper motor DIP switch access cover and adjust the setting. See figure 7.
- 3- Replace damper motor access cover and horizontal return panel.

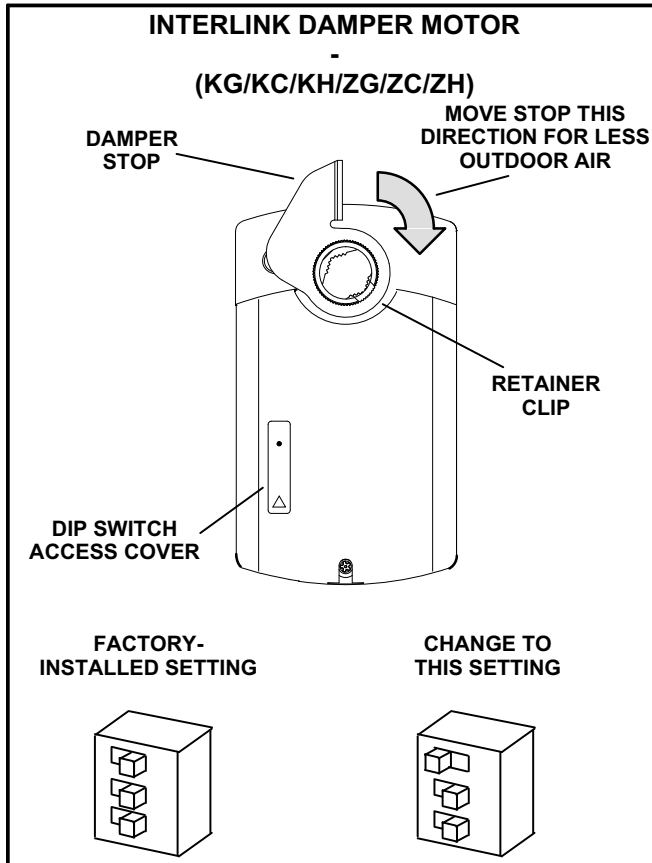

FIGURE 7

Wiring Diagrams

LG/LC/LH/LD/KG/KC/KH Units -

Affix the applicable wiring diagram on the inside of the control compartment access panel. Position diagram to the right of the "C" control section wiring diagram. LG/LC/LH/LD units use the diagram showing A55 in the key list. KG/KC/KH units use the diagram showing J160/P160 in the key list. Discard the unused diagram.

ZG/ZC/ZH Units -

Affix the appropriate wiring diagram on the inside of the control compartment access panel. Discard the other two diagrams.

Outdoor Air Hood - Motorized Damper

Outdoor air hood carton is shipped in the return air section when the dampers are factory-installed.

On LG/LC/LH/LD/KG/KC/KH units equipped with factory-installed dampers, go to step 3-.

1- LG/LC/LH/LD/KG/KC/KH Only -

Slide the top edge of hood pivot bracket between the unit cabinet top flange and the outdoor air assembly. See figure 9. Secure pivot bracket using retained end panel screws. Install, but do not tighten, the screws.

ZG/ZC/ZH Only -

Align four holes in hood pivot bracket with the dimples above opening in lower panel. Use self-drilling screws, provided, to install the hood pivot bracket, but do not tighten the screws. See figure 8.

2- Position the hood top V-channel under the corresponding V-channel on hood pivot bracket.

Slide hood from left to right until it is properly positioned. See figure 9.

3- *Factory-Installed Dampers Only* - Remove screws securing hood to unit. Lift hood upward allowing the hood to slide from left to right.

4- Secure left hood side to the hood top and to the cabinet using the provided screws. See figure 11.

5- Secure the right hood side to the hood top. Do not secure the right hood side to cabinet. See figure 12.

6- Align the two holes on the left hood side with the two holes in the bottom filter bracket. Secure using provided screws. See figure 11.

7- Secure bottom filter bracket to the right hood side as shown in figure 12.

8- Secure right hood side to cabinet using provided screws. See figure 12.

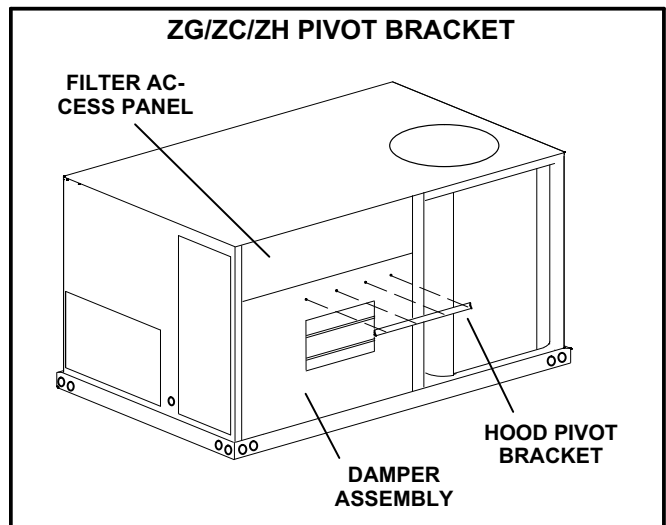

FIGURE 8

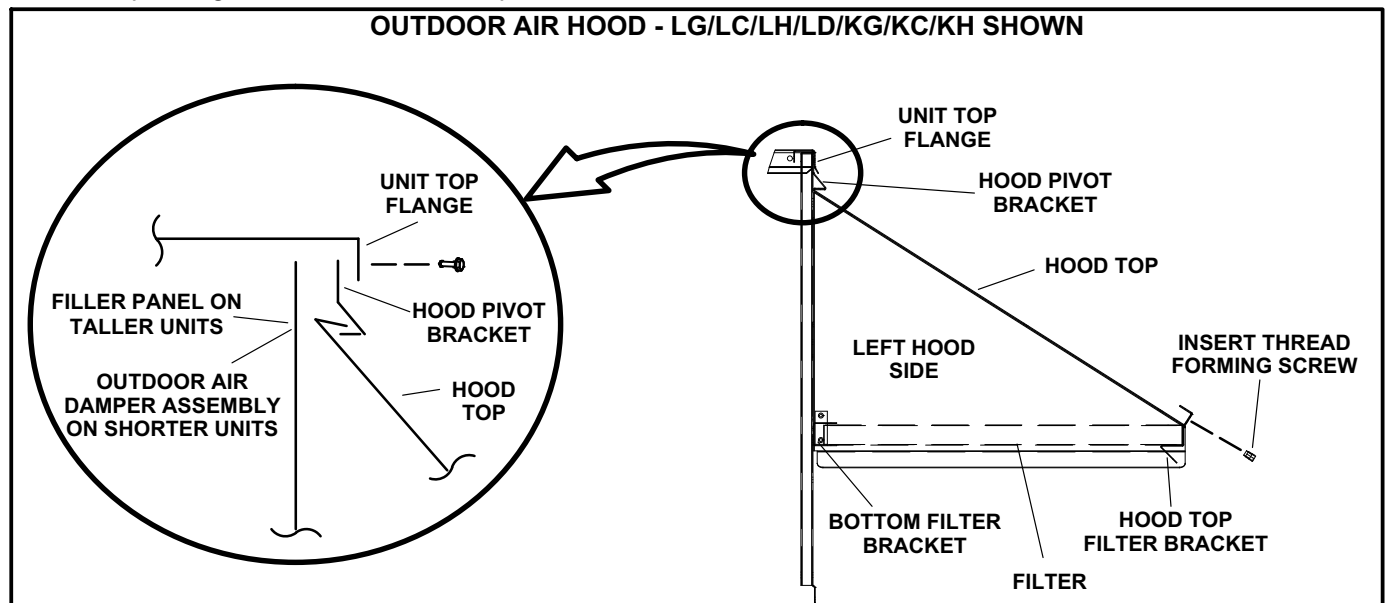

FIGURE 9

9- Slide filter into the slot on the bottom filter bracket. Make sure arrows on filter match airflow direction. Secure the hood top filter bracket to the hood top using the thread forming screw provided. See figure 11.

10- Tighten hood pivot bracket screws.

11- Seal the locations shown in figures 11 and 12 with caulk.

12- *LG/LC/LH/LD/KG/KC/KH Only* -

Locate the two retained screws removed from the hood top in figure 3. Install screws into the two open holes on the unit end panel below the assembled hood. See figure 10.

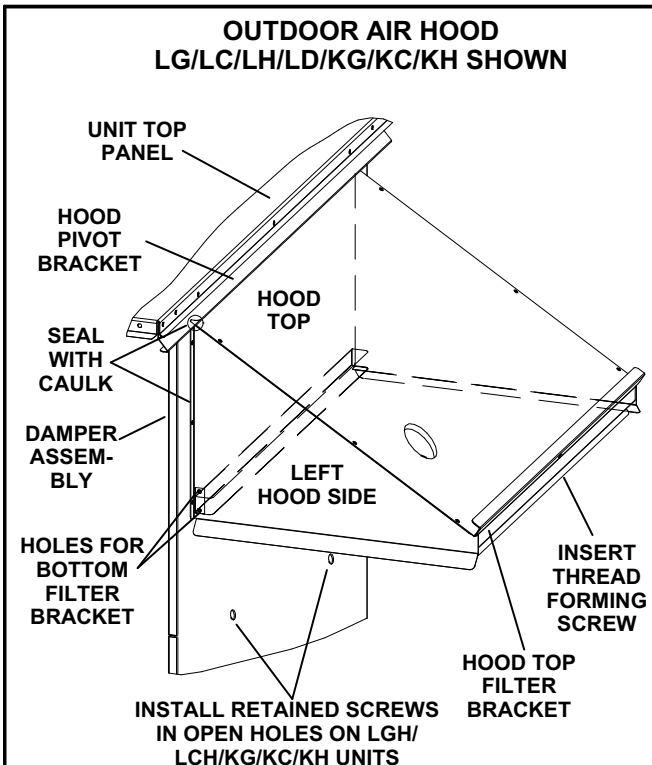

FIGURE 11

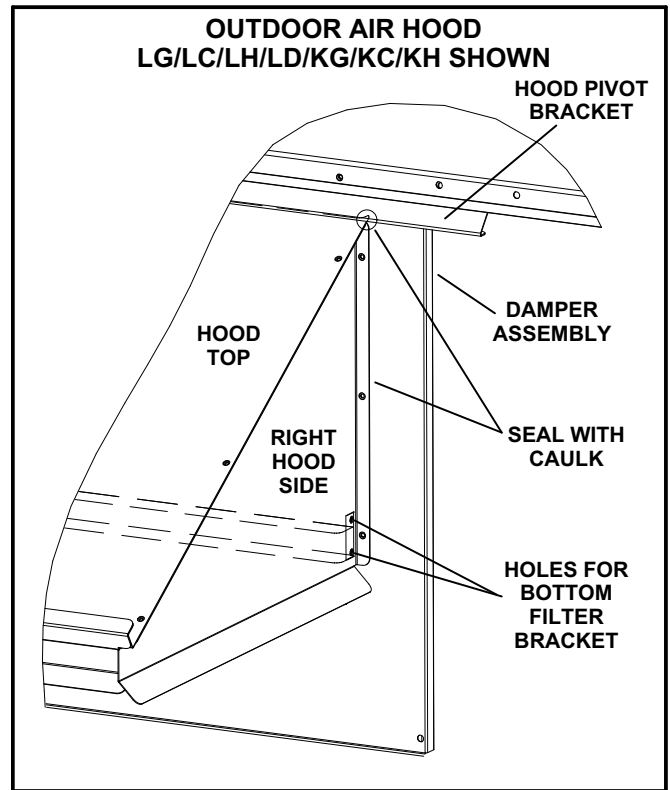

FIGURE 12

Install Manual Damper

- 1- Disconnect all power to the unit.
- 2- On LG/LC/LH/LD/KG/KC/KH units equipped with factory-installed dampers, go to *Outdoor Air Hood - Motorized Damper* section.

LG/LC/LH/LD/KG/KC/KH Units

- 3- Remove and retain screws securing end panel to the unit. See figure 1. Remove and discard end panel.
- 4- Insert top of damper assembly. See figure 14. Secure the bottom of the assembly using retained screws. Secure the top of the assembly with retained screws.

ZG/ZC/ZH Units

- 1- Disconnect all power to the unit.
- 2- Remove and discard unit back panel. Retain screws and two door brackets which secure panel. See figure 2.
- 3- Remove filter access panel. Retain panel and screws.
- 4- Position retained brackets on damper assembly and install below filter access panel. Secure damper

assembly and brackets to unit using retained screws. See figure 13.

- 5- Secure the bottom of the assembly with retained screws.

- 6- Replace filter access panel.

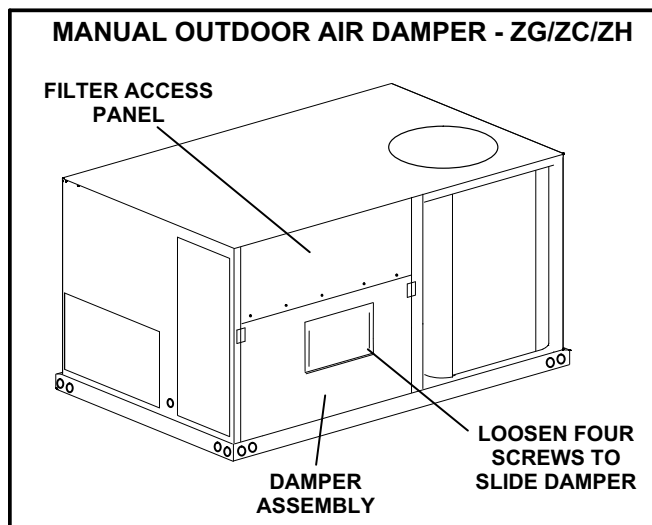

FIGURE 13

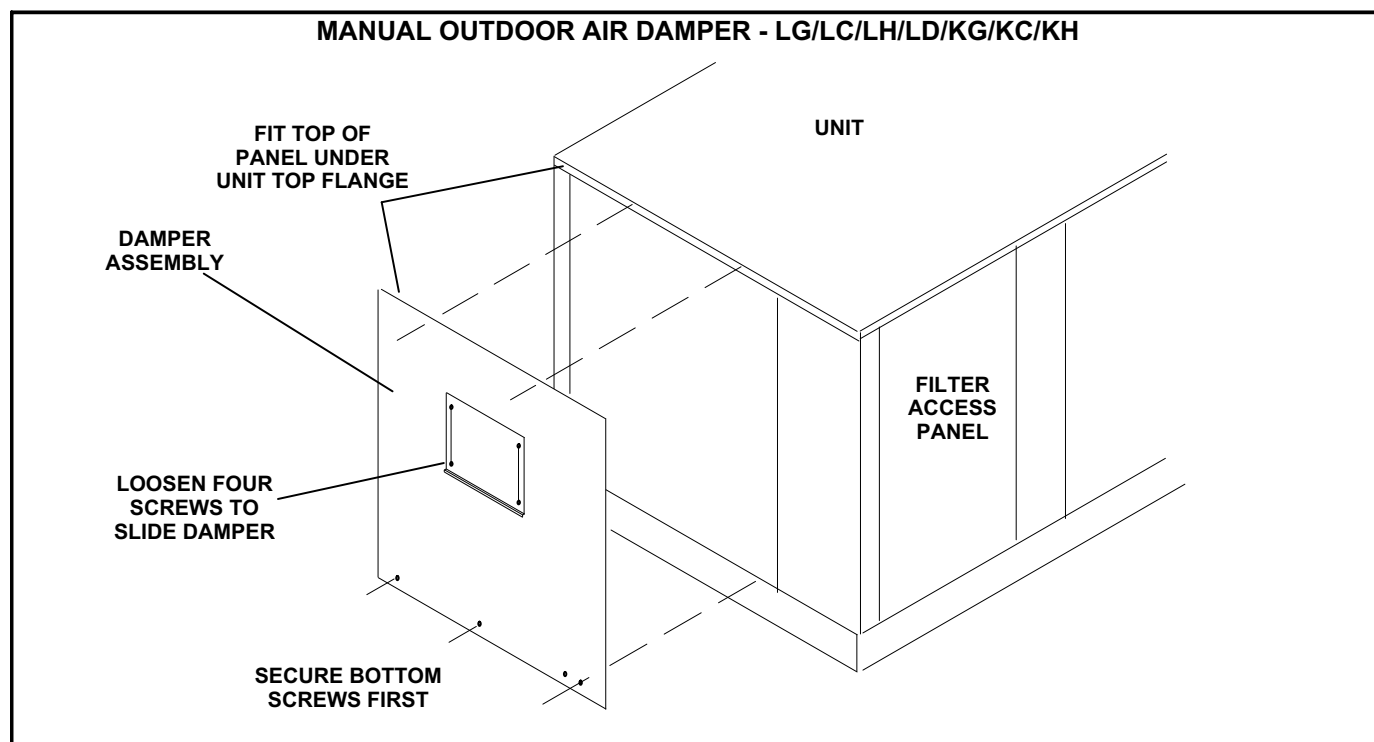

FIGURE 14

Outdoor Air Hood - Manual Damper

Hood is shipped in the return air section when the dampers are factory-installed.

- 1- Assemble hood as shown in figure 15.
- 2- Install mist eliminator filter as shown in figure 16. Make sure arrows on filter match airflow.
- 3- Secure hood to unit as shown in figure 17.
- 4- Install kit screws into the two open holes on the end panel below the hood. See figure 17.

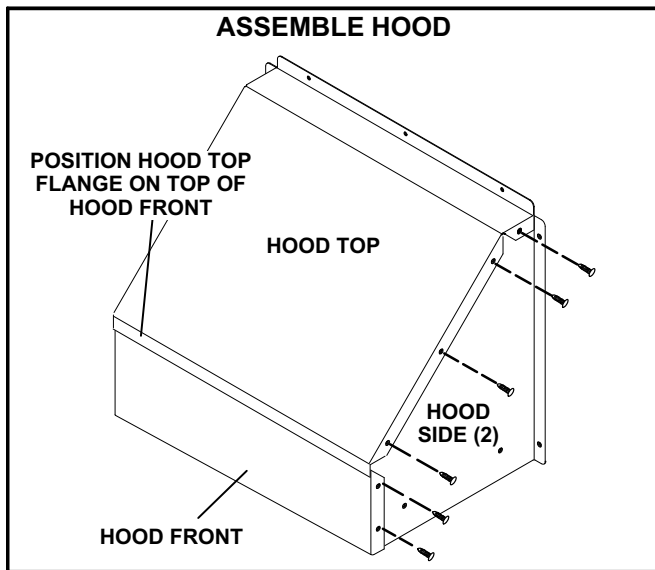

FIGURE 15

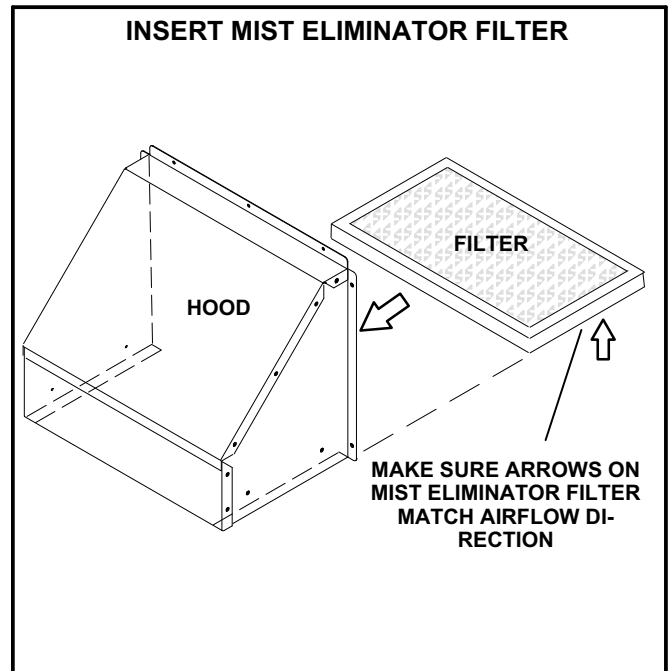

FIGURE 16

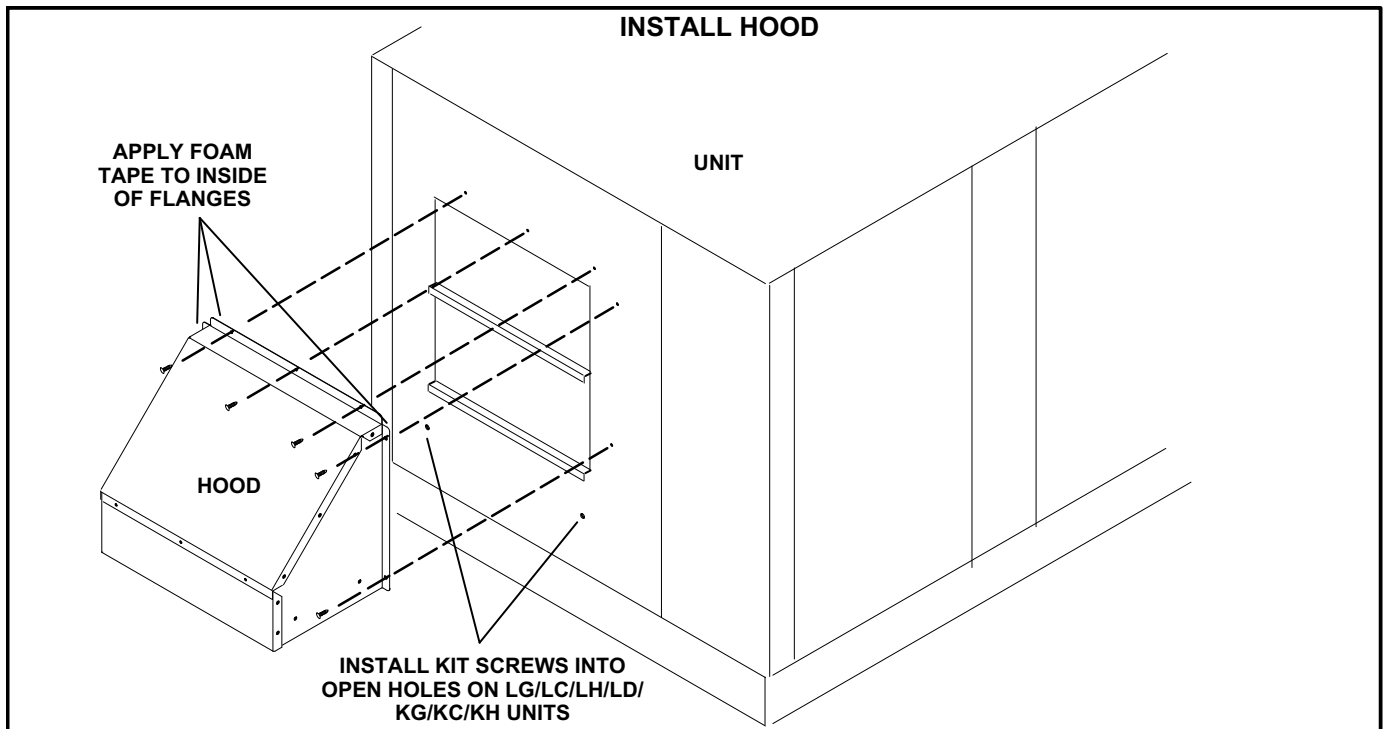

FIGURE 17

Determine Outdoor Air Percentage

Outdoor air percentage can be estimated in the same manner for both manual and motorized dampers. Measure outdoor air temperatures according to the following steps and calculate the outdoor air percentage. For motorized dampers, refer to unit specific damper adjustment details following these steps.

- 1- Measure outdoor air temperature. Mark the point on the bottom line of chart 1 and label the point "A" (40°F, 4°C shown).
- 2- Measure return air temperature. Mark that point on

the top line of chart 1 and label the point "B" (74°F, 23°C shown).

- 3- Measure mixed air (outdoor and return air) temperature. Mark that point on the top line of chart 1 and label point "C" (70°F, 21°C shown).
- 4- Draw a straight line between points A and B.
- 5- Draw a vertical line through point C.
- 6- Draw a horizontal line where the two lines meet. Read the percent of outdoor air intake on the side.
- 7- If outdoor air percentage is less or more than desired, increase or decrease minimum damper position. Then, repeat steps 2 through 7 until calculation reads desired outdoor air percentage.

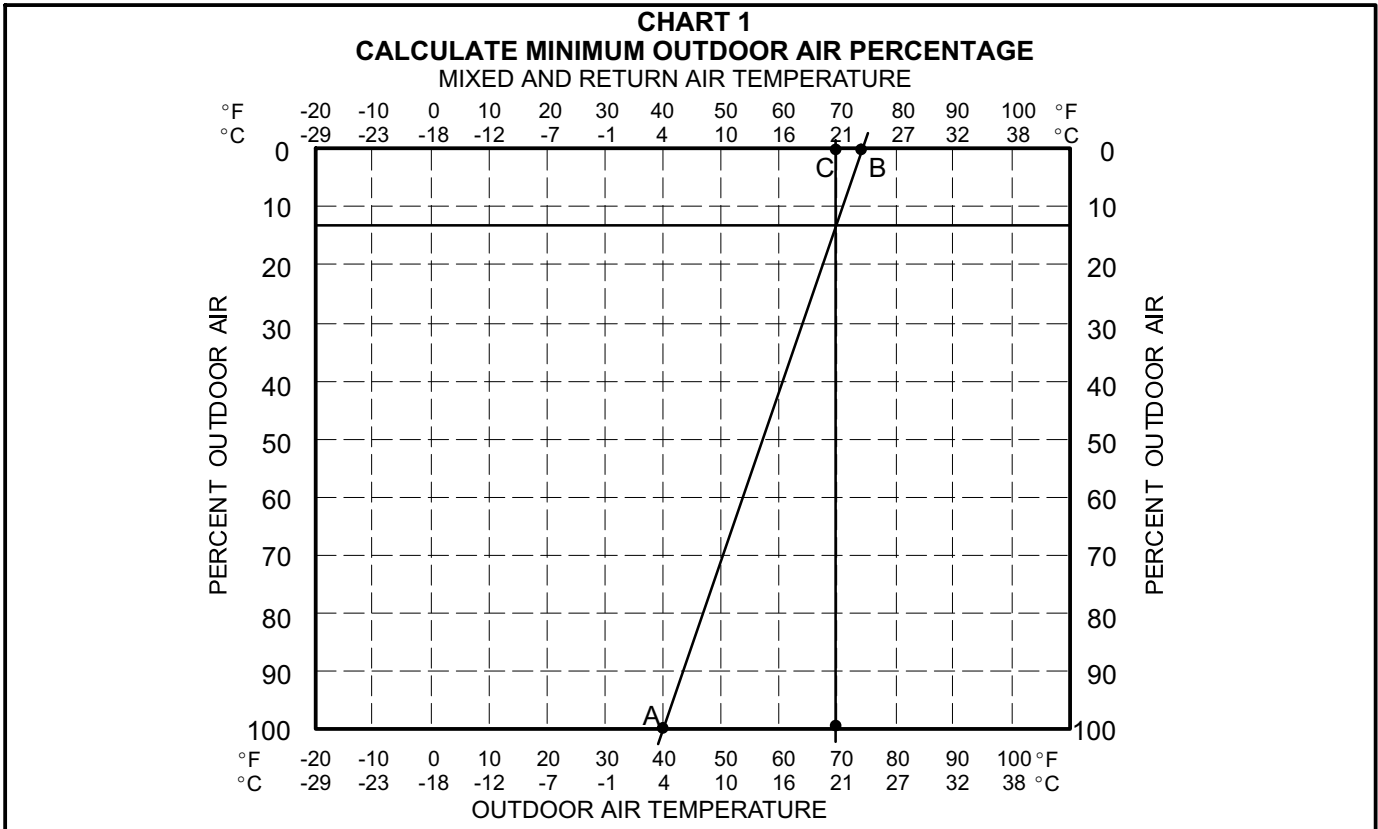

Damper Minimum Position Adjustments

Note - Unit Controller is factory-set when dampers are factory-installed.

The unit will be equipped with either an M2, M3, or M4 Unit Controller. M2 or M3 will be printed on the bottom of the Unit Controller near the SBUS connector. M4 will be printed near the LED display.

Units Equipped With M2 and M3 Unit Controllers

The damper minimum position or positions are adjusted using the Unit Controller input screen. For a unit equipped with more than 1 blower speed, the unit should initially be run on the highest speed.

1- Field-Installed Dampers Only -

Use one of the following menus to enable the motorized damper function on the Unit Controller.

M3 Unit Controller -

SETUP > INSTALL

Navigate through the various screens until CONFIGURATION ID 1 appears. Enable set position 2 to M (motorized outdoor air damper only).

M2 Unit Controller -

SETTINGS > INSTALL > NEW M2 > DAMPER > MOAD

2- Use one of the following menu paths to set the minimum damper position.

M3 Unit Controller -

SETUP > TEST & BALANCE > DAMPER > MIN DAMPER POSITION BLOWER ON HIGH=.%

M2 Unit Controller -

SETTINGS > SETPOINTS > DAMPER > MIN OCP BLOWER HIGH

3- Use the *Determine Outdoor Air Percentage* section to verify the minimum damper air percentage.

4- *Units Equipped With Two Blower Speeds -*

Use one of the following menu paths to set the low speed minimum damper position.

M3 Unit Controller -

SETUP > TEST & BALANCE > DAMPER > MIN DAMPER POSITION BLOWER ON LOW=.%

M2 Unit Controller -

SETTINGS > SETPOINTS > DAMPER > MIN OCP BLOWER LOW

5- Use the *Determine Outdoor Air Percentage* section to verify the low speed minimum damper air percentage.

Note - For additional details, refer to Unit Controller manual shipped with unit.

Units Equipped With M4 Unit Controllers

1- The Unit Controller must be configured to identify the motorized damper has been installed. Use the Unit Controller mobile app to enter the following menu:

RTU MENU > SETUP > INSTALL

Navigate through various setup questions until CONFIGURATION ID 1 appears. Change the second character to "M".

2- Use the following menu to set damper minimum position on blower **HIGH** speed.

SETUP > DAMPER > TEST & BALANCE > BLOWER SPEED HI - MINIMUM DAMPER POSITION

3- Use the *Determine Outdoor Air Percentage* section to verify the minimum damper air percentage.

4- Use the following menu to set damper minimum position on blower **LOW** speed.

SETUP > DAMPER > TEST & BALANCE > BLOWER SPEED LOW - MINIMUM DAMPER POSITION

5- Use the *Determine Outdoor Air Percentage* section to verify the minimum damper air percentage.

Units Not Equipped With A Unit Controller

The damper motor stop is preset to provide 100% outdoor air and is adjustable in fixed increments. For units supporting more than 1 blower speed, the damper minimum set point should be determined with the blower operating at the highest speed.

1- To reduce the outdoor air percentage, remove retainer clip and adjust damper stop in the clockwise direction. Replace the retainer clip securing the stop arm in the new position. See figure 7.

2- Power the damper open by providing a blower and occupied demand to the unit thermostat connections.

3- Use the *Determine Outdoor Air Percentage* section to verify the minimum damper air percentage.

4- Repeat steps 1 through 3 until calculation reads desired outdoor air percentage. Remove the blower and occupied demand signals before adjusting damper stop.

Minimum Damper Position Range

The motorized outdoor air damper operation is optimized as shown in the shaded area of Chart 2. Unit operation during minimum damper position above this curve increases the potential for rain being drawn into the unit.

- 1- Remove the metal mesh filter from the hood. Measure the static pressure differential between the return compartment (through horizontal return air panel is recommended) and outside the unit. Operate the unit with the damper open to minimum position. Record the single blower speed pressure differential in table 2.
- 2- *Units With More Than One Blower Speed -* Repeat the static pressure measurement at each blower speed and minimum set point combination. Record the multiple blower speed pressure differential in table 2.

3- Read the damper percentage open.

Units Equipped With Unit Controller -

The damper percentage open was entered into the Unit Controller.

Units Not Equipped With Unit Controller -

Operate the unit with the damper open to minimum position. Measure the voltage between pins 7 and 9 from the damper motor plug P4. Calculate the percentage open from the formula:

$$\% \text{ Open} = [(\text{Measure voltage} - 2.5) / 7.0] \times 100$$

- 4- Plot the damper % open and static pressure drop on Chart 2. Plot additional blower speeds in the same manner.
- 5- Replace the metal mesh filter.

TABLE 2

Single Blower Speed		Multiple Blower Speed	
Static Pressure Differential - "w.c.	Damper % Open	Static Pressure Differential - "w.c.	Damper % Open

