

PACKAGED UNITS KITS  
AND ACCESSORIES

506113-04  
11/2021  
Supersedes 506113-03

VFD REPLACEMENT KIT

INSTALLATION INSTRUCTIONS FOR VARIABLE FREQUENCY DRIVE (VFD)  
REPLACEMENT KITS

**⚠ WARNING**

Improper installation, adjustment, alteration, service or maintenance can cause property damage, personal injury or loss of life. Installation and service must be performed by a licensed professional HVAC installer or equivalent, service agency, or the gas supplier

**⚠ WARNING**

**ELECTRICAL SHOCK HAZARD.**

Failure to follow instructions exactly could result in serious injury or death.

**VFD HOLDS A POTENTIALLY LETHAL CHARGE UP TO 10 MINUTES AFTER POWER HAS BEEN DISCONNECTED.** Do not open VFD cover until 10 minutes AFTER power source has been disconnected and power lamp has turned off.

Read manual provided by VFD manufacturer. Carefully review and follow all safety warnings in that manual also.

**⚠ CAUTION**

As with any mechanical equipment, contact with sharp sheet metal edges can result in personal injury. Take care while handling this equipment and wear gloves and protective clothing.

**Shipping and Packing List**

Package 1 of 1 contains:

- 1- Pre-programmed VFD (A96 or A137)

**Application**

Kits are used to replace the variable frequency drive (VFD) in LG/LC, SG/SC, KG/KC/KH, TA/EL series units. See table 1 for VFDs without MODBUS cables and table 2 for VFDs with MODBUS cables.

**Installation - No MODBUS Cable**

- 1- Disconnect all power to unit and **WAIT AT LEAST 10 MINUTES** before opening the VFD cover. See figure 2 through 5 for location.

**⚠ WARNING**

**ELECTRICAL SHOCK HAZARD.**

**STOP!** Before you continue, make sure that power to the VFD has been off for at least 10 minutes. The capacitor in the VFD holds high voltage power for up to 10 minutes after power has been disconnected.

TABLE 1

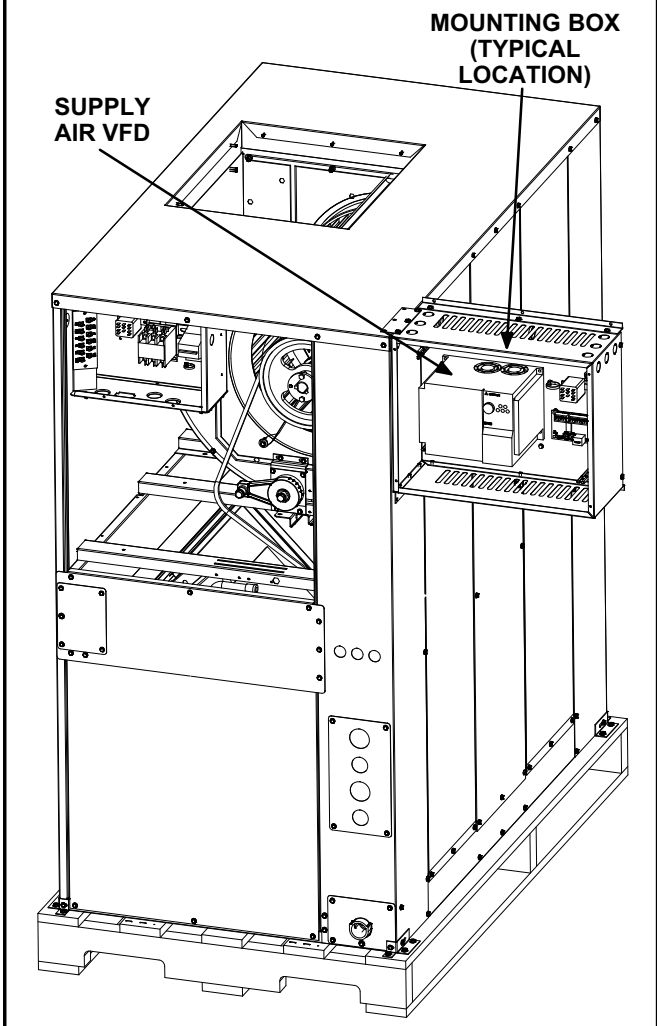
HP Rating	Voltage	Kit Number	Catalog Number
2HP	230V	615610-01	15G14
	460V	615610-02	15G16
	575V	615610-03	15G17
	380V/50Hz	615610-28	18D53
3HP	230V	615610-04	15G18
	460V	615610-05	15G19
	575V	615610-06	15G20
	380V/50Hz	615610-29	18D56
5HP	230V	615610-07	15G21
	460V	615610-08	15G22
	575V	615610-09	15G24
	380V/50Hz	615610-30	18D57
7.5HP	230V	615610-10	15G25
	460V	615610-11	15G26
	575V	615610-12	15G27
	380V/50Hz	615610-31	18D59
10HP	230V	615610-13	15G28
	460V	615610-14	15G29
	575V	615610-15	15G30
	380V/50Hz	615610-32	18D61
15HP	230V	615610-16	15G52
	460V	615610-17	15G53
20HP	575V	615610-18	15G69
	230V	615610-19	15G72
	460V	615610-20	15G73
25HP	575V	615610-21	15G74
	230V	615610-22	15G75
	460V	615610-23	15G76
30HP	575V	615610-24	15G77
	230V	615610-25	15G78
	460V	615610-26	15G79
	575V	615610-27	15G80



**TABLE 2**

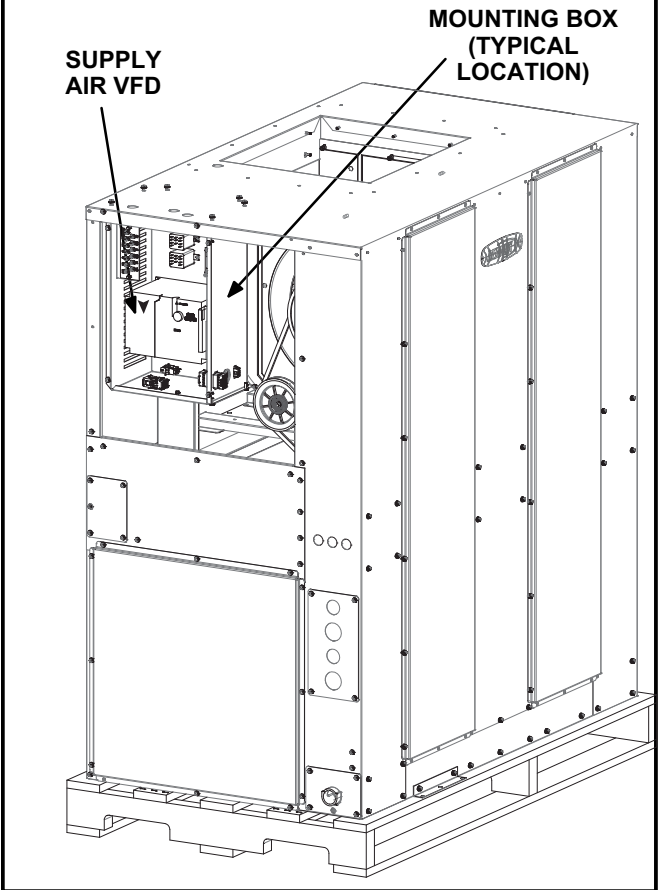
HP Rating	Voltage	Kit Number	Catalog Number
2HP	230V	622785-01	21Z39
	460V	622785-02	21Z40
	575V	622785-11	22V80
3HP	230V	622785-03	21Z41
	460V	622785-04	21Z42
	575V	622785-12	22V81
5HP	230V	622785-05	21Z43
	460V	622785-06	21Z44
	575V	622785-13	22V82
7.5HP	230V	622785-07	21Z45
	460V	622785-08	21Z46
	575V	622785-14	22V83
10HP	230V	622785-09	21Z49
	460V	622785-10	21Z50
	575V	622785-15	22V84

**VFD LOCATION-TA SPLIT SYSTEM AIR HANDLER**

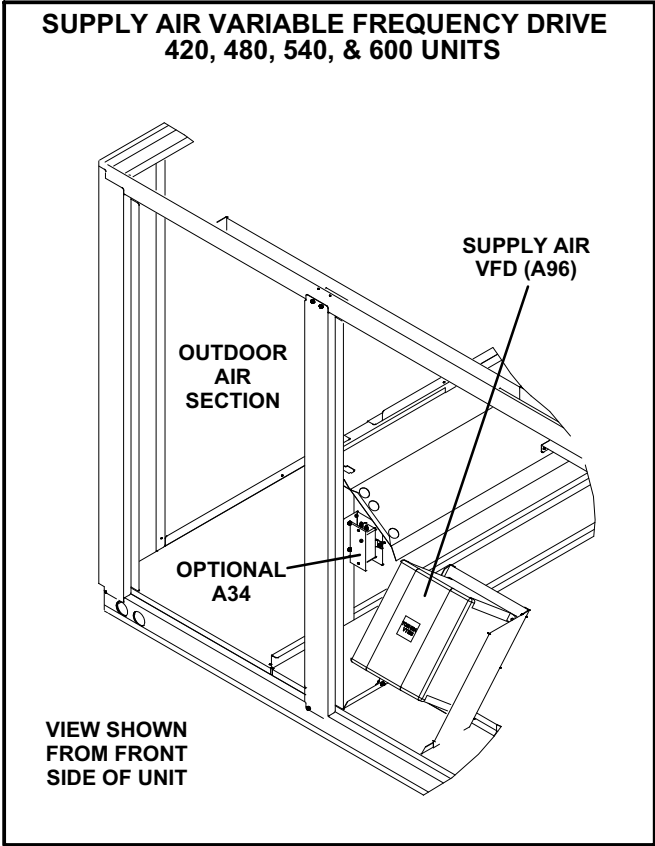


**FIGURE 1**

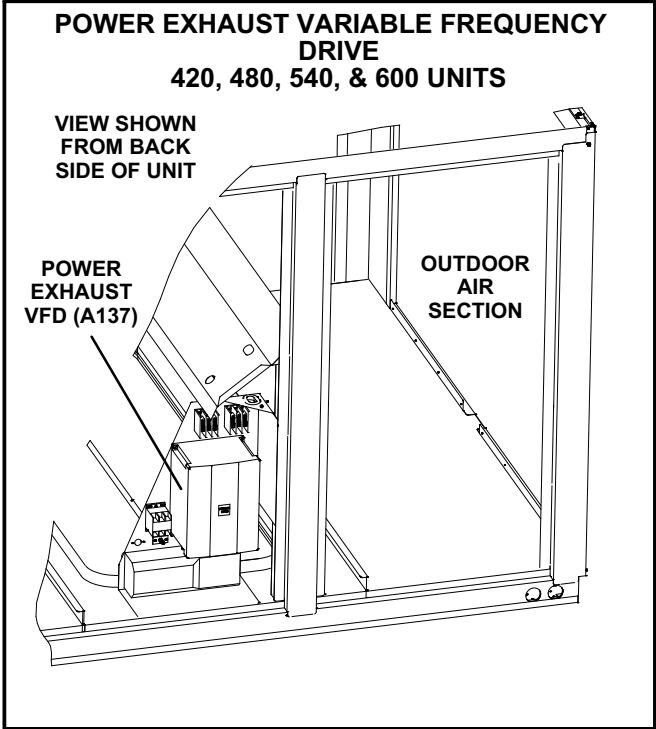
**VFD LOCATION-EL SPLIT SYSTEM AIR HANDLER**



**FIGURE 2**



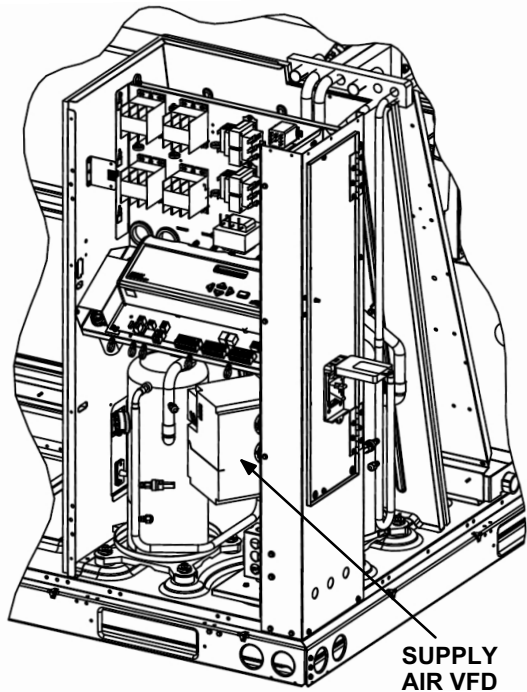
**FIGURE 3**



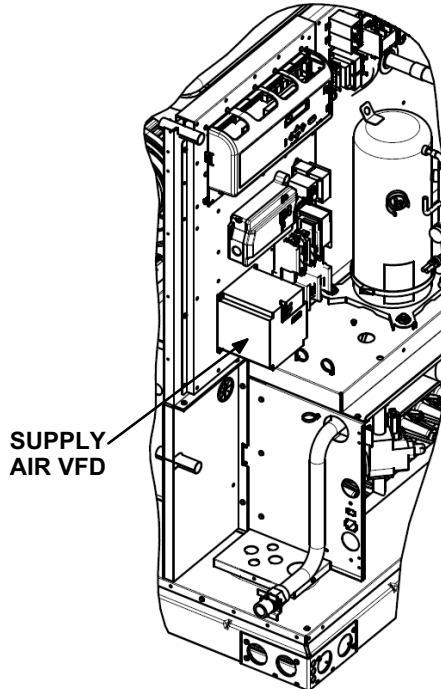
**FIGURE 4**

VFD LOCATION

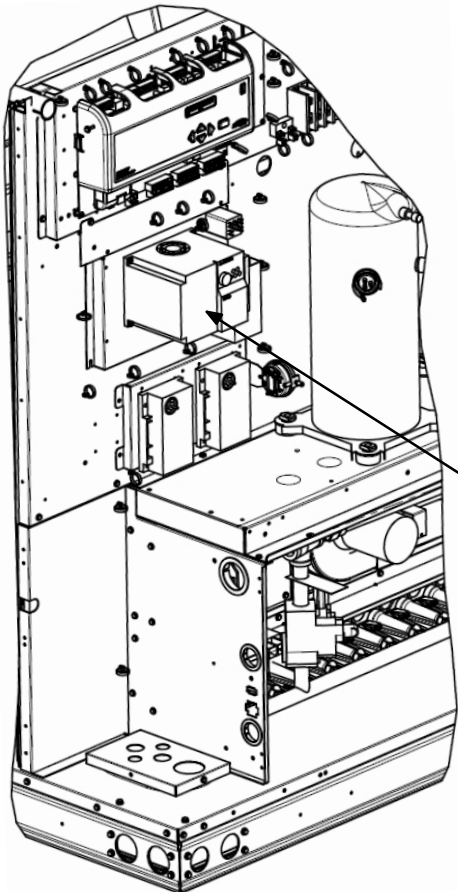
LGH/LCH092-150  
KG/KC/KH 092-150



SGC/SCC120



LGH/LCH156-300S  
KG/KC/KH 180-300



LGH/LCH242H-360H  
SGC/SCC240 & 288

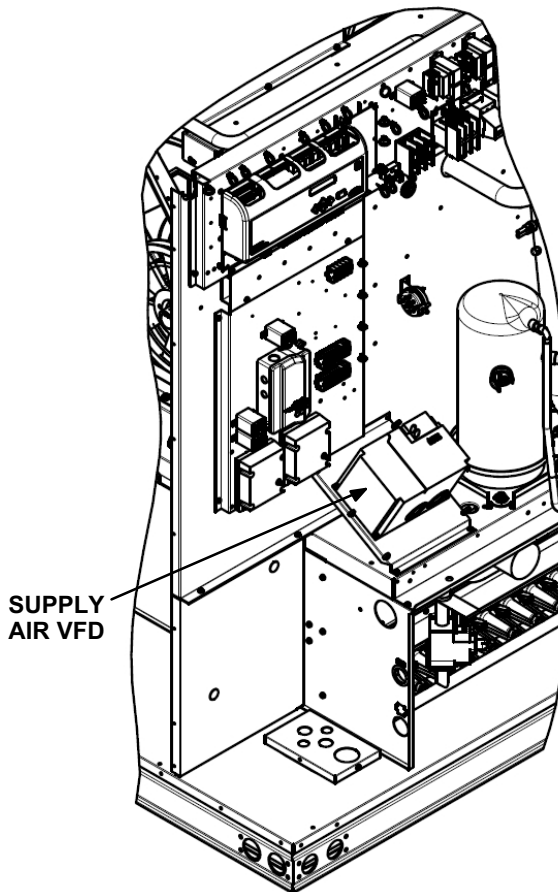


FIGURE 5

## Installation No MODBUS - continued

- Open the lower cover on the VFD to access wire connections. Disconnect the wires from the terminals, making special note of the wire color and stamping that was connected to each terminal. See figures 6 through 10.
- Remove the top two screws which secure the existing VFD to the mounting bracket. Loosen the lower two securing screws and remove the existing VFD from the controls compartment.

*NOTE - It is not necessary to completely remove the two lower screws to remove the VFD.*

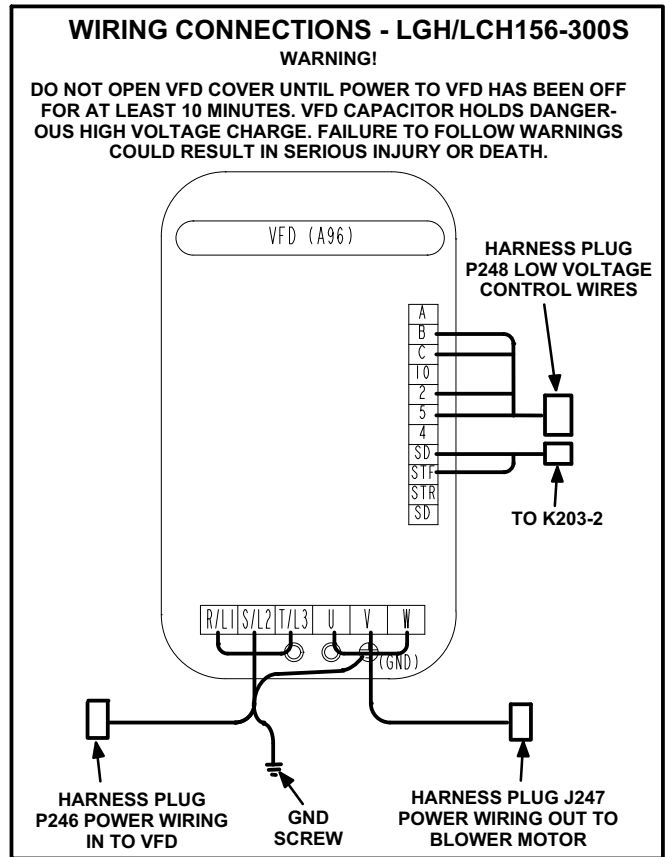
*NOTE - If the existing VFD is model E520 or E540 it may be necessary to drill new mounting holes in the VFD mounting plate. The model number is located on the VFD nameplate.*

- Slide keyholes on replacement VFD over lower securing screws. Reinsert and tighten two upper screws, then tighten lower screws.

## **⚠ WARNING**

**Power wiring must be connected properly. Improperly connected power wiring may result in damage to the VFD.**

- Carefully connect existing wires to the replacement VFD. On units without harnesses, take care to properly connect the power wiring going into and out of the VFD.
- Close access panel and restore power to the unit.

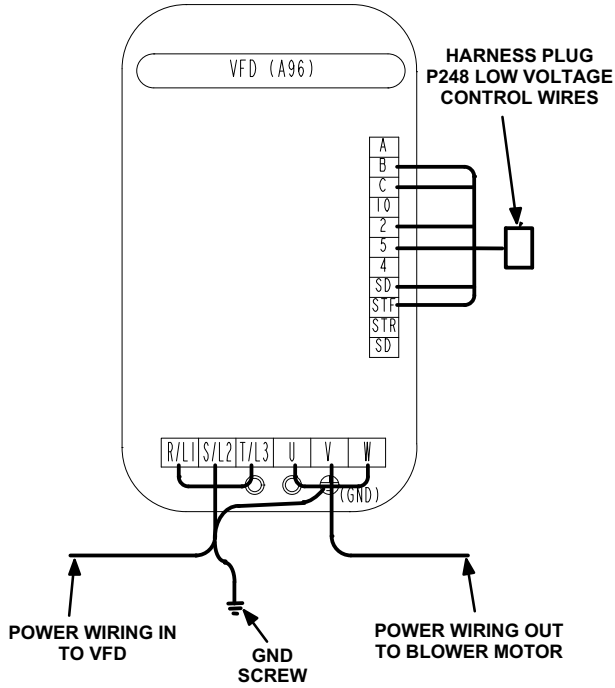


**FIGURE 6**

**WIRING CONNECTIONS -  
 LGH/LCH092-150 & 242H-360H; SGC/  
 SCC120-288;  
 LGH/LCH420-600**

**WARNING!**

**DO NOT OPEN VFD COVER UNTIL POWER TO VFD HAS BEEN OFF FOR AT LEAST 10 MINUTES. VFD CAPACITOR HOLDS DANGEROUS HIGH VOLTAGE CHARGE. FAILURE TO FOLLOW WARNINGS COULD RESULT IN SERIOUS INJURY OR DEATH.**

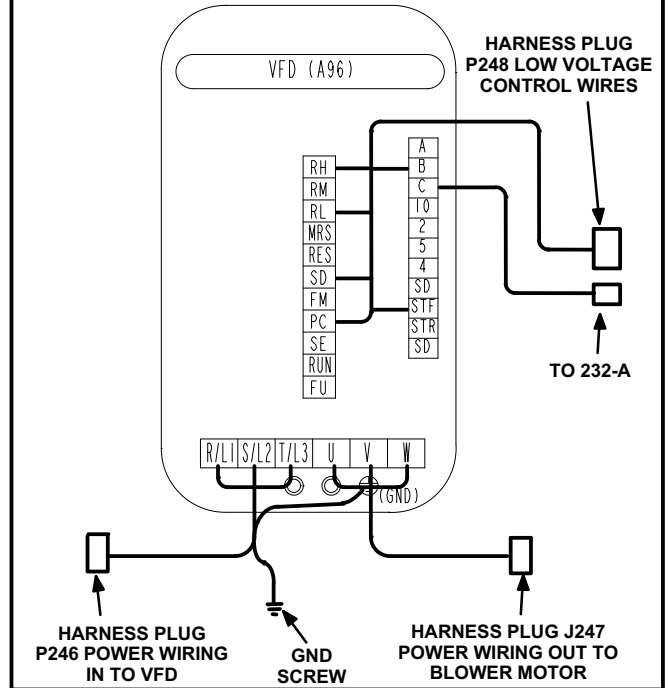


**FIGURE 7**

**WIRING CONNECTIONS - KG/KC/KH 180-300**

**WARNING!**

**DO NOT OPEN VFD COVER UNTIL POWER TO VFD HAS BEEN OFF FOR AT LEAST 10 MINUTES. VFD CAPACITOR HOLDS DANGEROUS HIGH VOLTAGE CHARGE. FAILURE TO FOLLOW WARNINGS COULD RESULT IN SERIOUS INJURY OR DEATH.**

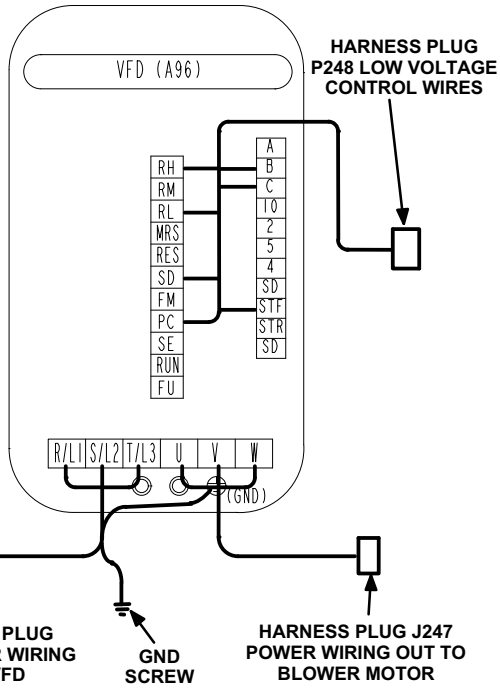


**FIGURE 8**

### WIRING CONNECTIONS - EL/KG/KC 092-150

**WARNING!**

DO NOT OPEN VFD COVER UNTIL POWER TO VFD HAS BEEN OFF FOR AT LEAST 10 MINUTES. VFD CAPACITOR HOLDS DANGEROUS HIGH VOLTAGE CHARGE. FAILURE TO FOLLOW WARNINGS COULD RESULT IN SERIOUS INJURY OR DEATH.

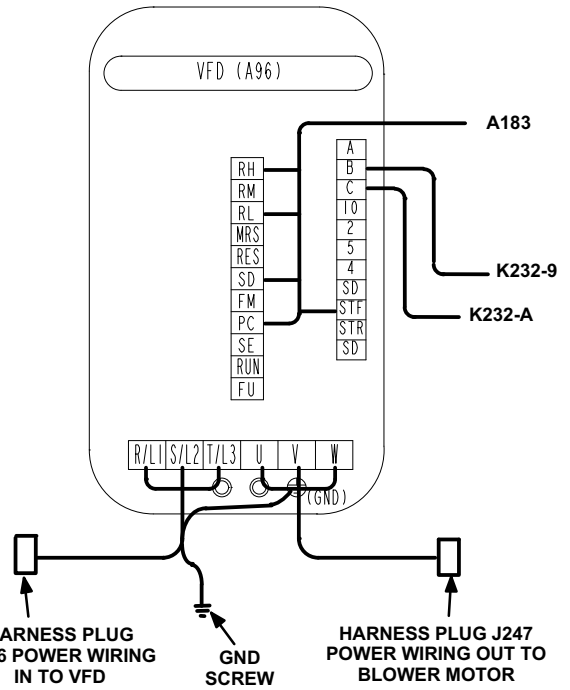


**FIGURE 9**

### WIRING CONNECTIONS - TA UNITS

**WARNING!**

DO NOT OPEN VFD COVER UNTIL POWER TO VFD HAS BEEN OFF FOR AT LEAST 10 MINUTES. VFD CAPACITOR HOLDS DANGEROUS HIGH VOLTAGE CHARGE. FAILURE TO FOLLOW WARNINGS COULD RESULT IN SERIOUS INJURY OR DEATH.



**FIGURE 10**

## Installation - With MODBUS Cable

- 1- Disconnect all power to unit and **WAIT AT LEAST 10 MINUTES** before opening the VFD cover. See figure 11 for location.
- 2- Mark the wires leading to the terminal block on the bottom of the VFD with appropriate terminal name. Disconnect wires from the terminal block. See figure 12.
- 3- Disconnect MODBUS from VFD.
- 4- Remove and retain four screws securing VFD to control panel.
- 5- Install the replacement VFD and secure with retained screws.
- 6- Reconnect MODBUS cable and terminal block wires.
- 7- Restore power to the unit.

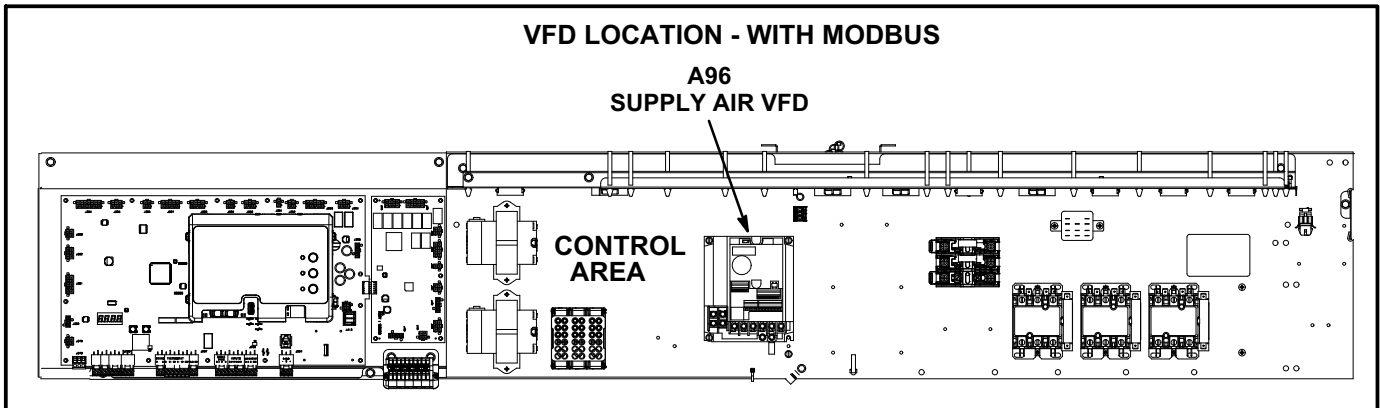


FIGURE 11

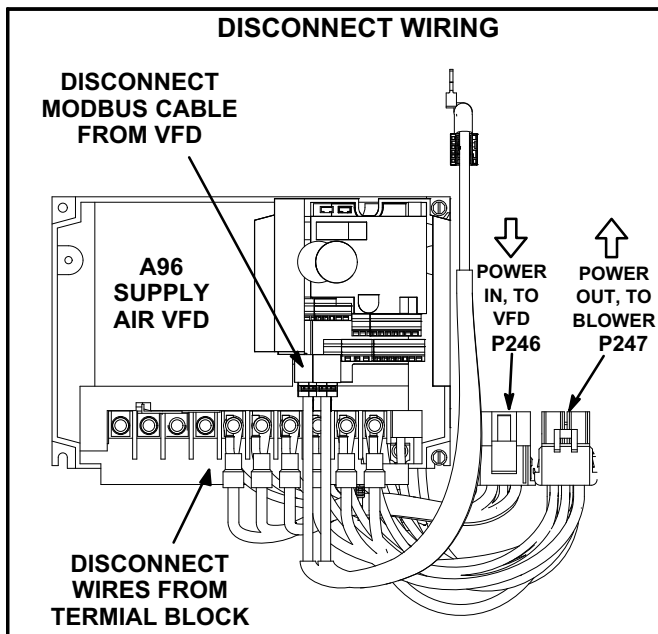


FIGURE 12

## Verify Proper Operation - All Units

If the blower is not rotating in the proper direction:

- 1- Disconnect all power to the unit and open the compressor / controls compartment access panel.
- 2- Reverse any two power wires going from the VFD to the blower motor.
- 3- Check all field wiring to the VFD. No wires should be connected to TB2-STR.
- 4- Check to ensure that wiring connections are secure.
- 5- Close access panel and restore power to unit.

### Verify proper operation of VFD:

Refer to staged supply air blower unit start-up instructions in unit installation instructions.

*Note - Operate unit in the heating mode or mode which operates at the highest blower speed. Measure amp draw to blower motor between the VFD and blower motor. Verify that the amperage does not exceed the FLA value listed on the motor nameplate.*