

KEY	COMPONENT
A42	MONITOR, PHASE PROTECTION
A96	CONTROL, INVERTER
A171	SENSOR ONE, SMOKE, RETURN AIR
A172	SENSOR TWO, SMOKE, SUPPLY AIR
A173	MODULE, CONTROL SMOKE DETECTION
A183	CONTROL, VFD BOARD
B1	COMPRESSOR 1
B2	COMPRESSOR 2
B3	MOTOR, BLOWER
B4	MOTOR, OUTDOOR FAN 1
B5	MOTOR, OUTDOOR FAN 2
B10	MOTOR, EXHAUST FAN 1
C1	CAPACITOR, OUTDOOR FAN 1
C2	CAPACITOR, OUTDOOR FAN 2
C6	CAPACITOR, EXHAUST FAN 1
CB8	CIRCUIT, BREAKER T1
DL46	DELAY, OVERFLOW SWITCH
HR1	HEATER COMPRESSOR 1
HR2	HEATER COMPRESSOR 2
J11	JACK, GFI, RECEPTACLE
K1-1,-2	CONTACTOR, COMPRESSOR 1
K2-1,-2	CONTACTOR, COMPRESSOR 2
K3, -1	CONTACTOR, BLOWER
K10,-1,2	RELAY, OUTDOOR FAN
K65-1,2	RELAY, EXHAUST FAN
K220,-1	RELAY, OVERFLOW DELAY
K232-2	RELAY, INVERTER PROTECTION
K264-1	RELAY, RL-RM TRANSFER
L34	SOLENOID, 2-SPEED COMPRESSOR
S4	SWITCH, LIMIT HI PRESS COMP 1
S5	SWITCH, LIMIT HI TEMP COMPRESSOR 1
S7	SWITCH, LIMIT HI PRESS COMP 2
S8	SWITCH, LIMIT HI TEMP COMPRESSOR 2
S48	SWITCH, DISCONNECT
S49	SWITCH, FREEZESTAT COMP 1
S50	SWITCH, FREEZESTAT COMP 2
S149	SWITCH, OVERFLOW
T1	TRANSFORMER, CONTROL
T18	TRANSFORMER, REHEAT
TB13	TERMINAL STRIP, POWER DISTRIBUTION

J/P	JACK/PLUG DESCRIPTION
2	HEAT
18	EXHAUST FAN COMPT
24	EXHAUST FAN
35	TEST
36	TEST COOL
86	OUTDOOR FANS 1
132	EXHAUST FAN MOTOR 1
246	POWER TO VFD
247	POWER VFD TO MOTOR
248	VFD CONTROL
249	CONTACTOR BYPASS
250	SMOKE DETECTOR ONE
251	SMOKE DETECTOR ONE
252	SMOKE DETECTOR TWO
253	SMOKE DETECTOR TWO
255	MODULE, CONTROL SMOKE DETECTION
261	SMOKE DETECTOR JUMPER
326	VFD CONTROL ADD-ON
328	VFD CONTROL ADD-ON
H1	HEADER 1, A183 VFD BOARD
H2	HEADER 2, A183 VFD BOARD

NOTE - IF ANY WIRE IN THIS APPLIANCE IS REPLACED IT MUST BE REPLACED WITH WIRE OF LIKE SIZE, RATING, TERMINATION AND INSULATION THICKNESS
 WARNING - ELECTRIC SHOCK HAZARD, CAN CAUSE INJURY OR DEATH UNIT MUST BE GROUNDED IN ACCORDANCE WITH NATIONAL AND LOCAL CODES
 DISCONNECT ALL POWER BEFORE SERVICING

— DENOTES OPTIONAL COMPONENTS
 — LINE VOLTAGE FIELD INSTALLED

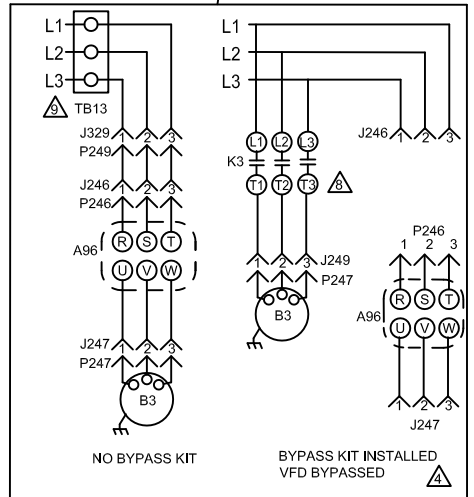

- NOTE - FOR USE WITH COPPER CONDUCTORS ONLY REFER TO UNIT RATING PLATE FOR MINIMUM CIRCUIT AMPACITY AND MAXIMUM OVERCURRENT PROTECTION SIZE.
- P2 IS USED ON KCA UNITS ONLY
- IMPORTANT: TO PREVENT MOTOR BURNOUT, NEVER CONNECT MORE THAN ONE MOTOR LEAD TO ANY ONE CONNECTION. TAPE UNUSED MOTOR LEADS
- TO BYPASS A96 VFD: DISCONNECT POWER SUPPLY UNPLUG P249 FROM J329; PLUG P249 INTO J249 UNPLUG P246 FROM J246; UNPLUG P247 FROM J247; PLUG P247 INTO J246 UNPLUG P328 FROM J325; PLUG P325 INTO J325 UNPLUG P326 FROM J35; UNPLUG P35 FROM J326; PLUG P35 INTO J35
- CONNECT A172 SENSOR TO J261 ON SUPPLY AIR SMOKE DETECTOR ONLY
- S48 OR CB10 MAY BE USED
- 120V FIELD PROVIDED POWER SUPPLY IS REQUIRED
- K3 REPLACES TB13 WHEN A96 VFD BYPASS OPTION IS INSTALLED
- REFERENCE LOW AMBIENT KIT INSTRUCTIONS FOR WIRING DIAGRAM WHEN KIT IS INSTALLED
- VFD TERMINALS FOR MITSUBISHI / DELTA DRIVES

2023/07		WIRING DIAGRAM	23/07
		538301-02	
COOLING			
KC/KG - 092, 102, 120, 150 - G, J, Y VFD UNITS			
SECTION B			REV. 0
Supersedes	New Form No.		
538301-01	538301-02		