



**COMMERCIAL
 PRODUCT SPECIFICATIONS**

Bulletin No. 210558
 August 2022
 Supersedes March 2022



SMART WIRE™ SYSTEM



**ASHRAE 90.1
 COMPLIANT**

13 to 25 Tons
Net Cooling Capacity - 148,000 to 270,000 Btuh
Optional Electric Heat - 15 to 90 kW

MODEL NUMBER IDENTIFICATION

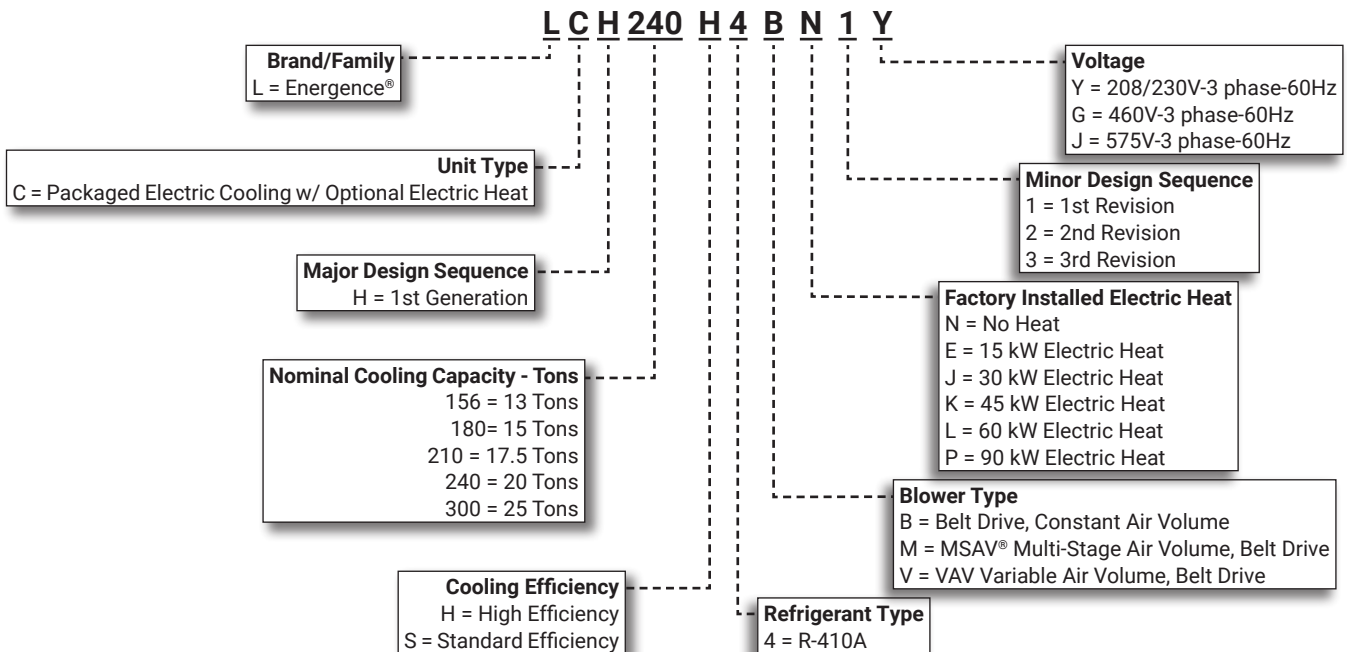

FEATURE HIGHLIGHTS

Lennox' Energence® packaged rooftop unit product line was created to save energy with intelligence by offering some of the highest energy efficiency ratings available with a powerful, easy to use unit controller. This makes Energence rooftop units perfect for business owners looking for an HVAC product with the lowest total cost of ownership.

1. Scroll Compressors
2. Thermal Expansion Valves
3. Filter/Driers
4. Environ™ Coil System
5. Outdoor Coil Fan Motors
6. Heavy Gauge Steel Cabinet
7. Hinged Access Panels
8. Constant or MSAV® Multi-Stage Air Volume Blower Option
9. Variable Frequency Drive (VFD)
10. Disconnect Switch (option)
11. Electric Heat (option)
12. Air Filters
13. Prodigy® Control System
14. Economizer (option)
15. Downflow Barometric Relief Dampers (option)
16. Power Exhaust Fans (option)

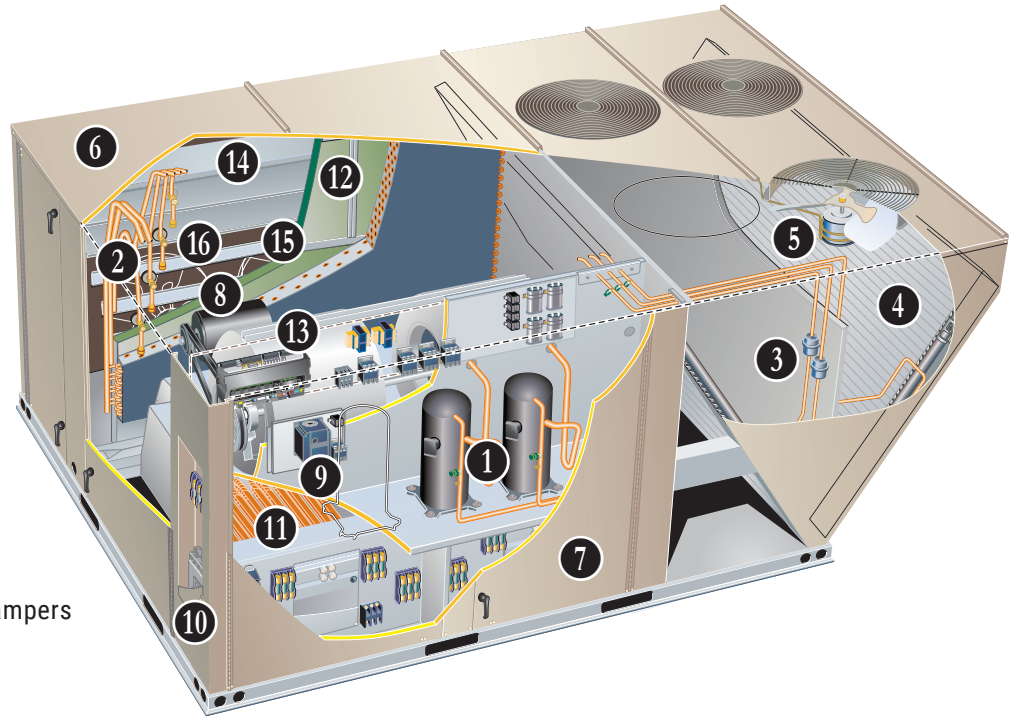

CONTENTS

Approvals And Warranty	3
Blower Data	44
Control System	8
Dimensions - Accessories	59
Dimensions - Unit	56
Electrical Accessories - Disconnects	52
Electrical/Electric Heat Data	47
Electric Heat Capacities	54
Features And Benefits	3
Humiditrol® Dehumidification System Option	12
Humiditrol® Dehumidification System Ratings	41
Model Number Identification	1
Optional Conventional Temperature Control Systems	14
Options / Accessories	24
Outdoor Sound Data	54
Ratings	32
Sequence Of Operation	16
Specifications	28
Unit Clearances	54
Weight Data	55

APPROVALS AND WARRANTY

APPROVALS

- AHRI Standard 340/360 certified
- ETL and CSA listed
- CSA certified energy ratings
- Unit and components ETL, NEC and CEC bonded for grounding to meet safety standards for servicing
- All models are ASHRAE 90.1-2010 energy efficiency compliant and meet or exceed requirements of Section 6.8
- All models meet DOE 2018 energy efficiency standards
- MSAV® Multi-Stage Air Volume models meet California Code of Regulations, Title 24 and ASHRAE 90.1-2010 Section 6.4.3.10 requirements for staged airflow
- ENERGY STAR® certified
- ISO 9001 Registered Manufacturing Quality System

WARRANTY

- Compressors - Limited five years
- Environ™ Coil System - Limited three years
- Prodigy® 2.0 Unit Controller - Limited three years
- Variable-Frequency Drive (VFD) (optional) - Limited five years
- High Performance Economizers (optional) - Limited five years
- All other covered components - Limited one year

FEATURES AND BENEFITS

COOLING SYSTEM

- Designed to maximize sensible and latent cooling performance at design conditions
- System can operate from 0°F to 125°F without any additional controls

R-410A Refrigerant

- Non-chlorine based
- Ozone friendly

1 Scroll Compressors

- Scroll compressors on all models for high performance, reliability and quiet operation
- Resiliently mounted on rubber grommets for quiet operation

Compressor Crankcase Heaters

- Protects against refrigerant migration that can occur during low ambient operation or during extended off cycles

2 Thermal Expansion Valves

- Ensures optimal performance throughout the application range
- Removable element head

3 Filter/Driers

- High capacity filter/drier protects the system from dirt and moisture

High Pressure Switches

- Protects the compressor from overload conditions such as dirty condenser coils, blocked refrigerant flow or loss of outdoor fan operation

Low Pressure Switches

- Protects the compressors from low pressure conditions such as low refrigerant charge or low/no airflow

Indoor Coil Freeze Protection

- Protects the evaporator coil from damaging ice build-up due to conditions such as low/no airflow or low refrigerant charge

4 Condenser Coil - Environ™ Coil System

- Lightweight, all aluminum brazed fin construction
- Constructed of three components
 - A flat extrusion tube
 - Fins in-between the flat extrusion tube
 - Two refrigerant manifolds

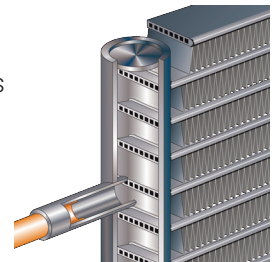

Environ™ Coil System Features:

- Improved heat transfer performance due to high primary surface area (flat tubes) versus secondary surface (fins)
- Smaller internal volume (reduced refrigerant charge)
- High durability
- All aluminum construction
- Fewer brazed joints
- Compact design
- Reduced unit weight
- Easy maintenance/cleaning
- Mounting brackets with rubber inserts secure coil to unit providing vibration dampening and corrosion protection
- Angled cabinet design protects coil from damage

FEATURES AND BENEFITS

COOLING SYSTEM (continued)

Evaporator Coil

- Copper tube construction
- Enhanced rippled-edge aluminum fins
- Flared shoulder tubing connections
- Silver soldered construction
- Factory leak tested
- Cross row circuiting with rifled tubing

NOTE - Constant air volume (CAV) and MSAV® Multi-Stage Air Volume models have face-split evaporator coils designed to keep condensate water off of an inactive part of the coil so the condensate will not re-enter the air stream.

Variable air volume (VAV) models have row-split, intertwined evaporator coils.

Condensate Drain Pan

- Plastic pan, sloped to meet drainage requirements per ASHRAE 62.1
- Side or bottom drain connections

5 Outdoor Coil Fan Motors

- Thermal overload protected
- Totally enclosed
- Permanently lubricated ball bearings
- Shaft up
- Wire basket mount

Outdoor Coil Fans

- PVC coated fan guard furnished

Required Selections

Cooling Capacity

- Specify nominal cooling capacity

Options/Accessories

Factory Installed

Conventional Fin/Tube Condenser Coil (replaces Environ™ Coil System)

- Copper tube construction
- Enhanced rippled-edge aluminum fins
- Flared shoulder tubing connections
- Silver soldered construction

NOTE - Not available for VAV equipped models.

Discharge Air Temperature Sensor

- Sensor sends information to the unit controller to cycle up to 2 stages of heating or 4 stages of cooling to maintain the discharge air setpoints for heating or cooling
- Optional for CAV units (single zone or bypass zoning control)

NOTE - Automatically furnished with all Variable Air Volume (VAV) units. Sensor is shipped with the unit for remote field installation in the supply duct

Service Valves

- Fully serviceable brass valves installed in discharge & liquid lines

NOTE - Not available for units equipped with Environ™ Coil System or Humiditrol® Dehumidification option.

Factory or Field Installed

Condensate Drain Trap

- Field installed only
- May be factory enclosed to ship with unit
- Available in copper or PVC

Drain Pan Overflow Switch

- Monitors condensate level in drain pan
- Shuts down unit if drain becomes clogged

CABINET

6 Construction

- Heavy-gauge steel panels
- Full perimeter heavy-gauge galvanized steel base rail
- Base rails have rigging holes
- Three sides of the base rail have forklift slots
- Raised edges around duct and power entry openings in the bottom of the unit for water protection

Airflow Choice

- Units are shipped in downflow (vertical) return air flow configuration

NOTE - Units can be field converted to horizontal air flow with optional Horizontal Return Air Panel Kit and Horizontal Roof Curb.

Power Entry

- Electrical lines can be routed through the unit base or through horizontal access knock-outs

Exterior Panels

- Constructed of heavy-gauge, galvanized steel
- Two-layer enamel paint finish

Insulation

- Fully insulated with non-hygroscopic fiberglass insulation (conditioned areas)
- Unit base is fully insulated
- Base insulation serves as an air seal to the roof curb, eliminating the need to add a seal during installation

7 Hinged Access Panels

- Filter section
- Blower section
- Heating section
- Compressor/controls section
- Panel seals and quarter-turn latching handles provide a tight air and water seal

Required Selections

Airflow Configuration

- Specify downflow or horizontal

FEATURES AND BENEFITS

CABINET (continued)

Options/Accessories

Factory Installed

Corrosion Protection

- Completely flexible immersed coating
- Electrodeposited dry film process (AST ElectroFin E-Coat)
- ASTM B117 / DIN 53167 Salt Spray - 15,000+ hours
- ASTM G85 Annex A3 SWAAT Modified Salt Spray - 3000 hours
- VA Master Construction Specification Division 23 for High Humidity Installations
- CID AA-52474A (GSA)
- Indoor Corrosion Protection:
 - Coated coil
 - Coated reheat coil
 - Painted blower housing
 - Painted base
- Outdoor Corrosion Protection:
 - Coated coil
 - Painted outdoor base

Field Installed

Combination Coil/Hail Guards

- Heavy gauge steel frame
- Painted to match cabinet
- Expanded metal mesh protects outdoor coil

Horizontal Return Air Panel Kit

- Required for horizontal applications with Horizontal Roof Curb
- Contains panel with return air opening for field replacement of existing unit panel and panel to cover bottom return air opening in unit
- See dimension drawings

BLOWER

- A wide selection of supply air blower options are available to meet a variety of airflow requirements

Motor

- Overload protected
- Ball bearings
- Belt drive motors are offered on all models and are available in several different sizes to maximize air performance

NOTE - All blower motors 5 hp and above meet minimum energy efficiency standards in accordance with the Energy Independence and Security Act (EISA) of 2007

Supply Air Blower

- Forward curved blades
- Double inlet
- Blower wheel statically and dynamically balanced

- Ball bearings
- Adjustable pulley (allows speed change)
- Blower assembly slides out of unit for servicing
- Grease fittings furnished

Supply Static Pressure Transducer (156/180/240 VAV Models Only)

- Sends information to the Prodigy® 2.0 unit controller to control VFD blower speed
- Shipped with the unit for remote field installation in the supply duct

Required Selections

8 Select Constant Air Volume (CAV), Variable Air Volume (VAV) or MSAV® Multi-Stage Air Volume

- Constant Air Volume (CAV) models supply a constant volume of air
- Variable Air Volume (VAV) (156/180/240 Models Only) variable frequency drive (VFD) varies the air volume to maintain a constant duct static pressure
- MSAV® Multi-Stage Air Volume models stage the amount of airflow according to compressor stages, heating demand, ventilation demand or smoke alarm

NOTE - Units with the MSAV® Multi-Stage Air Volume supply air blower option have the same face split indoor coils as units with the CAV supply air blower option. Part load airflow in cooling mode on MSAV® Multi-Stage Air Volume units should not be set below 220 cfm/nominal full load ton to reduce the risk of evaporator coil freeze-up.

- Utilizes a Variable Frequency Drive (VFD) to stage the supply blower airflow
- VFD alters the frequency and voltage of the power supply to the blower to control blower speed
- The amount of airflow for each stage can be set according to a parameter in the Prodigy® 2.0 unit controller
- Unit is shipped from the factory with preset airflow
- MSAV® Multi-Stage Air Volume can be ordered with or without an Electronic Bypass Control
- If equipped with the bypass control the MSAV® Multi-Stage Air Volume features manual (default) or automatic electronic bypass control of the VFD
- In case of a VFD malfunction, a VFD alarm is generated by the Prodigy® 2.0 unit controller
- VFD can be manually bypassed to continue unit operation at full blower speed
- Or the unit controller can be set to automatically switch to full blower speed if a VFD alarm is generated
- VFD has an operational range of 0 to 125°F outdoor air ambient temperature
- Lower operating costs are obtained when the blower is operated on lower speeds

Ordering Information

- Specify motor horsepower and drive kit number when base unit is ordered

FEATURES AND BENEFITS

BLOWER (continued)

NOTE - Units equipped a Variable Frequency Drive (VFD) are designed to operate on balanced, three-phase power. Operating units on unbalanced three-phase power will reduce the reliability of all electrical components in the unit. Unbalanced power is a result of the power delivery system supplied by the local utility company. Factory-installed inverters are sized to drive blower motors with an equivalent current rating using balanced three-phase power. If unbalanced three-phase power is supplied the installer must replace the existing factory-installed inverter with an inverter that has a higher current rating to allow for the imbalance. Refer to the installation instructions for additional information and replacement information.

Options/Accessories

Factory Installed

Blower Belt Auto-Tensioner

- Provides proper tension to belt drive blower belt without the need for regular adjustments
- Maintains airflow and proper performance

ELECTRICAL

NOTE - All units include terminal block and fuse block in power entry junction box for single power entry application.

SmartWire™ System

- Keyed and color-coded wiring connectors prevent miswiring
- Wire coloring scheme is standardized across all models
- Each connection is intuitively labeled to make troubleshooting and servicing quick and easy

Electrical Plugs

- Positive connection electrical plugs connect common accessories or maintenance parts for easy removal or installation

Required Selections

Voltage Choice

- Specify when ordering base unit

Options/Accessories

Factory Installed

Circuit Breakers

- HACR type
- Overload and short circuit protection
- Factory wired and mounted in the power entry panel
- Current sensitive and temperature activated
- Manual reset

SCR (Silicon Controlled Rectifier) Electric Heat Control

- Modulates small, precise increments of power to the electric heat load eliminating temperature fluctuations associated with mechanical controls
- Almost instantaneous operation with no moving parts
- Zero-Cross (fast cycling) feature improves electric heater life with less contraction and expansion of the heating elements
- The SCR operates when there is no call for heat from the building control system or thermostat
- SCR air tempering is controlled by a secondary thermostat and remote duct sensor (ordered separately)
- A call for heat overrides the SCR and modulates the SCR to 100% heat output
- A call for cooling overrides the SCR

NOTE - SCR option is not available with 45 kW, 60 kW and 90kW electric heat (208/230V) models.

NOTE - Blower Proving Switch is required and must be ordered separately for factory installation. See Controls in the Options/Accessories table.

NOTE - Available for use with conventional thermostat controls or Novar® control systems only.

Short-Circuit Current Rating (SCCR)

- Higher short-circuit protection up to 100kA

NOTE - Disconnect Switch not available with higher SCCR option. Short-Circuit Current Rating option not available on field installed electric heat or 90kW electric heat (208/240V) models.

Phase/Voltage Detection (Optional for CAV Models Only)

- Monitors power supply to assure phase is correct at unit start-up
- If phase is incorrect, the unit will not start and an alarm code is reported to the unit controller
- Protects unit from being started with incorrect phasing which could lead to issues such as compressors running backwards
- Voltage detection monitors power supply voltage to assure proper voltage
- If voltage is not correct (over/under voltage conditions) the unit will not start and an alarm code is reported to the unit controller

NOTE - Phase/voltage detection is furnished when the MSAV (Multi-Stage Air Volume) option is ordered.

FEATURES AND BENEFITS

ELECTRICAL (continued)

Options/Accessories

Factory or Field Installed

- 9 **Disconnect Switch**
 - Accessible outside of unit
 - Spring loaded weatherproof cover furnished
- 10 **Electric Heat**
 - Helix wound nichrome elements
 - Individual element limit controls
 - Wiring harness
 - Unit fuse block
 - See Options/Accessories tables for ordering information
- 11 **GFI Service Outlets (2)**
 - 115V ground fault circuit interrupter (GFCI) type options:
 - Factory installed and wired, unit powered
 - Factory installed, non-powered, field wired
 - Field installed, non-powered, field wired

Field Installed

GFI Weatherproof Cover

- Single-gang cover
- Heavy-duty UV-resistant polycarbonate case construction
- Hinged base cover with gasket

INDOOR AIR QUALITY

- 12 **Air Filters**
 - Disposable 2 inch filters furnished as standard

Options/Accessories

Factory or Field Installed

Healthy Climate® High Efficiency Air Filters

- Disposable MERV, MERV 13 or MERV 16 (Minimum Efficiency Reporting Value based on ASHRAE 52.2) efficiency 2-inch pleated filters

Replacement Filter Media Kit With Frame

- Replaces existing pleated filter media
- Includes washable metal mesh screen and metal frame with clip for holding replaceable non-pleated filter

Field Installed

Healthy Climate® UVC Germicidal Light Kit

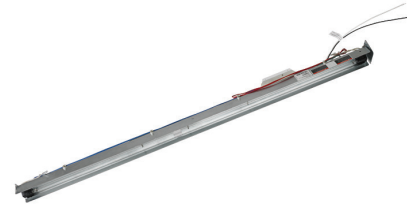

- Germicidal lamps emit ultra-violet (UV-C) energy, which has been proven to be effective in reducing microbes such as viruses, bacteria, yeasts, and molds
- This process either destroys the organism or controls its ability to reproduce
- UV-C energy greatly reduces the growth and proliferation of mold and other bioaerosols (bacteria and viruses) on illuminated surfaces (particularly coil and drain pan)
- Field installed in the blower/evaporator coil section
- Magnetic safety interlock terminates power when access panels are removed
- All necessary hardware for installation is included
- Lamps operate on 110/230V, 1 phase power supply

NOTE - Step-down transformer may be ordered separately for 460V and 575V units.

- Approved by ETL

Indoor Air Quality (CO₂) Sensors

- Monitors CO₂ levels, reports to the Prodigy® 2.0 unit controller which adjusts economizer dampers as needed

Needlepoint Bipolar Ionization (NPBI) Kit

- NPBI technology integrates with system controls for effective air treatment
 - Ionization has been shown to effectively reduce harmful pathogens, pollutants and odors
- NOTE** - Please visit www.sciencedirect.com for additional information.
- Brush-type ionizer introduces a high concentration of both positive and negative ions into the airstream
 - These bipolar ions are then dispersed into the occupied space through the duct system proactively reducing the airborne contaminants
 - Ions travel within the building air stream and attach to particles, pathogens, and gas molecules, making them larger and easier to capture in the filtration system
 - UL 2998 certified for zero ozone emission

CONTROL SYSTEM

PRODIGY® CONTROL SYSTEM



13 The Prodigy 2.0 unit controller is a microprocessor-based controller that provides flexible control of all unit functions.

Features:

- LCD Display
- Easy to read menu (4 lines x 20 character display)
- Buttons for menu navigation during setup and diagnostic
- Menu navigation LEDs for Data, Setup, Service, Settings
- Main Menu and Help Buttons for quick navigation to home screen and built-in help functions
- Scroll, Value Adjustment Select and Save Buttons
- Setup menu insures proper installation and simplified setup of the rooftop unit
- Profile setup copies key settings between units with the same configuration to reduce setup time
- USB port allows a technician to download and transfer unit information to help verify service was performed
- USB software updates on the Prodigy Control System enhance functionality without the need to change components
- Unit Controller Software
- Unit self-test verifies individual critical component and system performance
- Economizer test function assures economizer is operating correctly
- Time Clock with Run-Time Information

Built-In Functions Include:

- Adjustable Blower On/Off Delay
- Built-in Control Parameter Defaults
- Compressor Time-Off Delay
- DDC Compatible
- Dirty Filter Switch Input
- Discharge Air Temperature Control
- Display/Sensor Readout
- Economizer Control Options (See Economizer / Exhaust Air / Outdoor Air sections)
- Fresh Air Tempering
- Over 100 diagnostic and status messages in English
- Exhaust Fan Control Modes for fresh air damper position
- Permanent Diagnostic Code Storage
- Field Adjustable Control Parameters (Over 200 settings)
- Indoor Air Quality Input (Demand Control Ventilation)
- Low Ambient Controls for cooling operation down to 0°F
- Gas Valve Time Delay Between First and Second Stage

- Minimum Compressor Run Time
- Network Capable (Can be daisy chained to other units or controls)
- Night Setback Mode
- Return Air Temperature Limit Control
- Safety Switch Input allows Controller to respond to a external safety switch trip
- Service Relay Output
- Smoke Alarm Mode has four choices (unit off, positive pressure, negative pressure, purge)
- Up to 2 heat/2 cool (standard Prodigy unit controller thermostat input)
- Up to 3 cool with additional relay
- Up to 4 cool with room sensor or network operation
- "Strike Three" Protection
- Gas Reheat Control allows simultaneous heating and cooling operation for humidity control of process air applications such as supermarkets
- On Demand Dehumidification monitors and controls condenser hot gas reheat operation with Humiditrol® dehumidification option
- Thermostat Bounce Delay
- Warm Up Mode Delay
- LED Indicators
- PC Interface connects the Prodigy 2.0 unit controller to a PC with the Lennox Unit Controller Software
- Room Sensor Operation controls temperature

NOTE - Prodigy Control System features shown vary with the type of rooftop unit the control is installed in.

NOTE - See separate Prodigy Control System Product Specifications Bulletin for additional information.

CONTROL SYSTEM

PRODIGY® CONTROL SYSTEM (continued)

Control Options

Factory or Field Installed

Blower Proving Switch

- Monitors blower operation, shuts down unit if blower fails

Dirty Filter Switch

- Senses static pressure increase indicating dirty filter condition

Fresh Air Tempering

- Used in applications with high outside air requirements
- Controller energizes the first stage heat as needed to maintain a minimum supply air temperature for comfort, regardless of the thermostat demand
- When ordered as a factory option, sensor ships with the unit for field installation

Smoke Detector

- Photoelectric type
- Installed in supply air section, return air section or both sections
- Available with power board and single sensor (supply or return) or power board and two sensors (supply and return)
- Power board located in unit control compartment

Interoperability via BACnet® or LonTalk® Protocols

- Communication compatible with third-party automation systems that support the BACnet Application Specific Controller device profile, LonMark® Space Comfort Controller functional profile, or LonMark Discharge Air Controller functional profile

Commercial Control Systems

After-Market DDC

- Novar® Unit Controller and options

Thermostats

- Control system and thermostat options

Field Installed

General Purpose Control Kit

- Plug-in control provides additional analog and digital inputs/outputs for field installed options

Humidity Sensor Kit

- Humidity sensor required with factory installed Humiditrol® dehumidification option or Supermarket reheat field selectable option

OPTIONS / ACCESSORIES

ECONOMIZER

- Economizer operation is set and controlled by the Prodigy 2.0 unit controller
- Simple plug-in connections from economizer to unit controller for easy installation
- All Emergence rooftop units are equipped with factory installed CEC Title 24 approved sensors for outside, return and discharge air temperature monitoring

NOTE - Optional sensors may be used instead of unit sensors to determine whether outdoor air is suitable for free cooling. See Options/Accessories table.

Factory or Field Installed

14 High Performance Economizer

- Approved for California Title 24 building standards
- Low leakage dampers are Air Movement and Control Association International (AMCA) Class 1A Certified - Maximum 3 CFM per sq. ft. leakage at 1 in. w.g.
- ASHRAE 90.1-2010 compliant
- Outdoor Air Hood with mist elimination is included when economizer is factory installed and is furnished with economizer when ordered for field installation
- Gear-driven action
- High torque 24-volt fully-modulating spring return damper motor
- Return air and outdoor air dampers
- Plug-in connections to unit
- Stainless steel bearings
- Enhanced neoprene blade edge seals
- Flexible stainless steel jamb seals

NOTE - High Performance Economizers are not approved for use with enthalpy controls in Title 24 applications.

NOTE - The Free Cooling setpoint for Title 24 applications must be set based on the Climate Zone where the system is installed. See Section 140.4 "Prescriptive Requirements for Space Conditioning Systems" of the California Energy Commission's 2013 Building Energy Efficiency Standards.

NOTE - Refer to Installation Instructions for complete setup information.

OPTIONS / ACCESSORIES

ECONOMIZER (continued)

Differential Sensible Control

- Factory setting
- Uses outdoor air and return air sensors that are furnished with the unit
- The Prodigy® 2.0 unit controller compares outdoor air temperature with return air
- When the outdoor air is below the configured setpoint and cooler than return air, the controller activates the economizer

NOTE - Differential Sensible Control can be configured in the field to provide Offset Differential Sensible Control or Single Sensible Control.

NOTE - In Offset Differential Sensible Control mode, the economizer is enabled if the temperature differential (offset) between outdoor air and return air reaches the configured setpoint. In Single Sensible Control mode, the economizer is enabled when outdoor air temperature falls below the configured setpoint.

Global Control

- The unit controller communicates with a DDC system with one global sensor (enthalpy or sensible)
- Determines whether outside air is suitable for free cooling on all units connected to the control system
- Sensor must be field provided

Factory or Field Installed

Single Enthalpy Temperature Control (Not for Title 24)

- Outdoor air enthalpy sensor enables Economizer if the outdoor enthalpy is less than the setpoint of the control

Differential Enthalpy Control (Not for Title 24)

- Order two Single Enthalpy Controls
- One is field installed in the return air section
- One is installed in the outdoor air section
- Allows the economizer control to select between outdoor air or return air, whichever has lower enthalpy

Field Installed

Outdoor Air CFM Control

- Maintains constant outdoor air volume levels on the supply air fan and varying unit airflows
- Velocity sensor located in the rooftop unit outdoor air section, the Prodigy® 2.0 unit controller changes the economizer position to help minimize the effect of supply fan speed changes on outdoor air volume levels
- Setpoint for outdoor air volume is established by field testing

NOTE - Not available with Demand Control Ventilation (CO₂ Sensor) or Building Pressure Control.

Building Pressure Control

- Maintains constant building pressure level
- Includes a static pressure transducer and outdoor static pressure assembly
- Using differential pressure information between the outdoor air and the building air, the Prodigy® 2.0 unit controller changes the economizer position to help maintain a constant building pressure

NOTE - Not available with Demand Control Ventilation (CO₂ Sensor) or Outdoor Air CFM Control.

EXHAUST

Factory or Field Installed

15 Downflow Barometric Relief Dampers

- Allow relief of excess air
- Aluminum blade dampers prevent blow back and outdoor air infiltration during off cycle
- Exhaust hood is factory installed when dampers are factory installed with economizer
- Exhaust hood is furnished with dampers when ordered for field installation
- Bird screen furnished

16 Power Exhaust Fans

- Install internal to unit for downflow applications only with economizer option
- Provides exhaust air pressure relief
- Interlocked to run when supply air blower is operating
- Fans run when outdoor air dampers are 50% open (adjustable)
- Motor is overload protected
- Dual propeller type fans are 20 in. diameter
- Five blades
- Two 1/3 hp motors
- SCCR rated

NOTE - Requires Economizer with furnished Outdoor Air Hood and Downflow Barometric Relief Dampers.

NOTE - MSAV® Multi-Stage Air Volume and VAV (Variable Air Volume) models are equipped with 2-stage power exhaust fans. Power exhaust operates in 1st stage (one fan) up to 70% of supply air blower speed. Both exhaust fans operate in 2nd stage when supply air blower speed is above 70% (adjustable) of full speed.

OPTIONS / ACCESSORIES

EXHAUST (continued)

Field Installed

Horizontal Barometric Relief Dampers

- For use when unit is configured for horizontal applications requiring an economizer
- Allows relief of excess air
- Aluminum blade dampers prevent blow back and outdoor air infiltration during off cycle
- Field installed in return air duct
- Bird screen and hood furnished

OUTDOOR AIR

Factory or Field Installed

Outdoor Air Damper

- Downflow or Horizontal
- Linked mechanical dampers
- 0 to 25% (fixed) outdoor air adjustable
- Installs in unit
- Includes outdoor air hood
- Automatic model features fully modulating spring return damper motor with plug-in connection
- Manual model features parallel blade, gear-driven dampers with adjustable fixed position

ROOF CURBS

Field Installed

- Nailer strip furnished (downflow only)
- Mates to unit
- US National Roofing Contractors Approved
- Shipped knocked down

Downflow

Hybrid Roof Curbs

- Interlocking tabs fasten corners together
- No tools required for assembly
- Can also be fastened together with furnished hardware
- Available in 8, 14, 18, and 24 inch heights

Adjustable Pitch Curb

- Fully adjustable pitch curbs (3/4 in. per foot in any direction) provide a level platform for rooftop units allowing flexible installations on roofs with uneven or sloped angles
- Interlocking tabs fasten corners together
- No tools required for assembly
- Hardware is furnished to connect upper curb with lower curb
- Available in 14 inch height

Horizontal

- Meet National Roofing Code requirements
- Converts unit from downflow to horizontal (side) air flow
- Return air is on unit, supply air is on curb
- See dimension drawings
- Available in 26, 30, 37, and 41 inch heights

NOTE - Requires Horizontal Return Air Panel Kit.

NOTE - Optional Insulation Kit is available to help prevent sweating.

Adaptor Curbs (not shown)

- Curbs are regionally sourced
- Dimensions vary based upon the source

NOTE - Contact your local sales representative for a detailed cut sheet with applicable dimensions.

CEILING DIFFUSERS

Field Installed

Ceiling Diffusers

(Flush or Step-Down)

- White powder coat finish on diffuser face and grilles
- Insulated UL listed duct liner
- Diffuser box has collars for duct connection
- Step-down diffusers have double deflection blades
- Flush diffusers have fixed blades
- Provisions for suspending
- Internally sealed to prevent recirculation
- Removable return air grille
- Adapts to T-bar ceiling grids or plaster ceilings

Transitions (Supply and Return)

- Used with diffusers
- Installs in roof curb
- Galvanized steel construction
- Flanges furnished for duct connection to diffusers
- Fully insulated

HUMIDITROL® DEHUMIDIFICATION SYSTEM OPTION

OVERVIEW

NOTE - Humiditrol® Dehumidification System Only Available For CAV And MSAV® Multi-Stage Air Volume Models.

- Factory installed option designed to control humidity
- Provides dehumidification on demand using ASHRAE 90.1 recommended method for comfort conditioning humidity control
- Unit comes equipped with one row reheat coil, solenoid valve and humidity controller
- A thermostat with a dehumidification output, a dehumidistat, or a DDC controller with an isolated output is required to control humidity and must be located in the occupied space

NOTE - Remote Mounted Humidity Sensor Kit is required for field installation. The humidity sensor provides input to the Unit Controller which is used to control activation of the dehumidification operation.

BENEFITS

- Improves indoor air quality
- Helps prevent damage due to high humidity levels
- Improves comfort levels by reducing space humidity levels

OPERATION

No Dehumidification Demand

- The unit will operate conventionally whenever there is a demand for cooling or heating and no dehumidification demand
- Free cooling is only permitted when there is no demand for dehumidification

Dehumidification Demand Only

- The Unit Controller is factory set at 60% relative humidity setpoint and can be adjusted at the Unit Controller or with optional Unit Controller Software

NOTE - Controls are not furnished and must be ordered extra.

- Reheat operation will initiate on a dehumidification demand and does not require a cooling demand
- The unit will operate in the dehumidification mode until the relative humidity of the conditioned space is below the setpoint
- The reheat coil is sized to provide 68°F to 75°F supply air during reheat operation
- This reduces sensible cooling capacity and extends compressor run time to control humidity when the cooling load is low
- A solenoid valve diverts hot gas from the compressor to the reheat coil
- The cooled and dehumidified air from the evaporator is reheated as it passes through the reheat coil
- The de-superheated and partially condensed refrigerant continues to the outdoor condenser coil where condensing is completed
- Unit will continue to operate in this mode until the dehumidification demand is satisfied

Dehumidification and Cooling Demand (Thermostat/ Room Sensor Application)

- If both a dehumidification and a full cooling load demand occur, the system will operate in cooling until the cooling demand is satisfied
- Then the system will energize the dehumidification mode.

Options/Accessories

Humidity Sensor Kit

- Remote Mounted Humidity sensor required with factory installed Humiditrol® Dehumidification Option or Supermarket reheat field selectable option

HUMIDITROL® DEHUMIDIFICATION SYSTEM OPTION

REFRIGERANT SCHEMATIC (156H, 180H and 210H MODELS ONLY)

NOTE: Refrigerant circuits one and two operates when there is a first-stage thermostat demand.

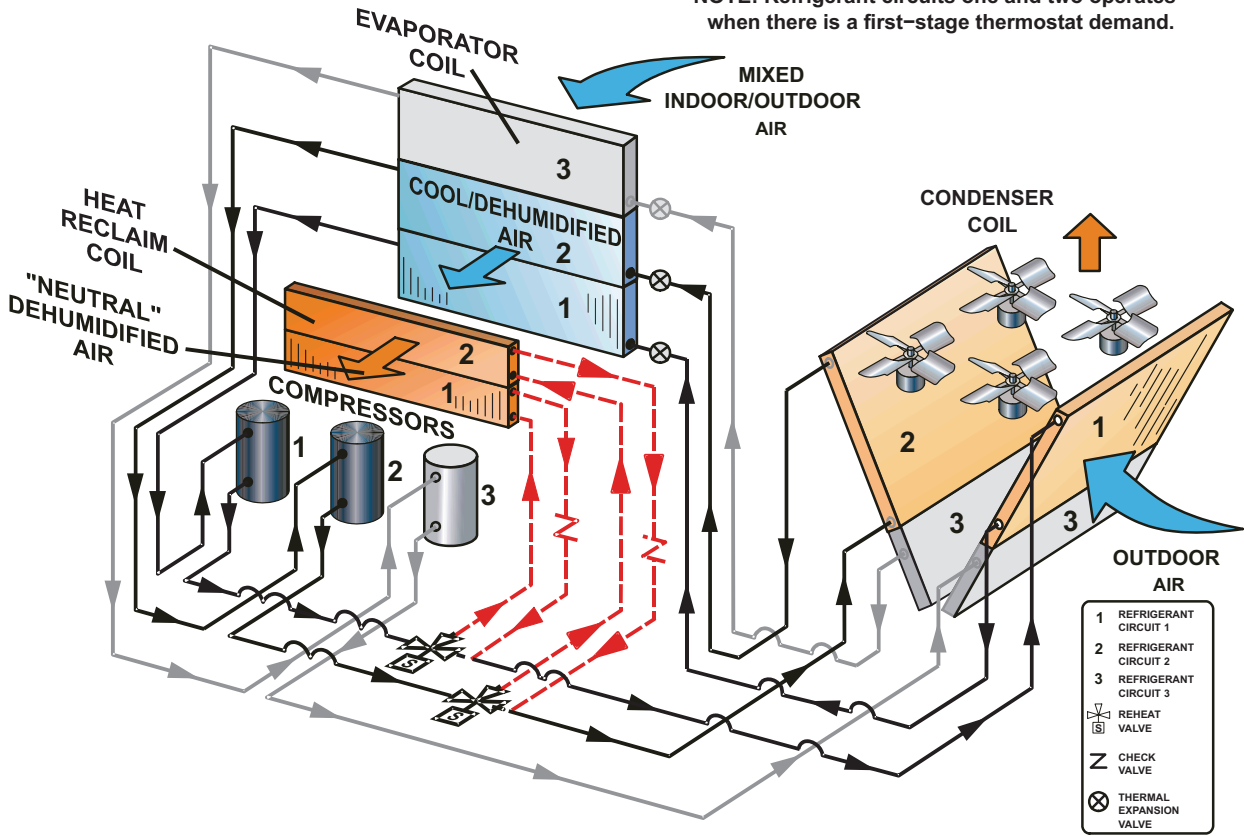

REFRIGERANT SCHEMATIC (240H and 300S MODELS ONLY)

NOTE: Refrigerant circuits one and two operates when there is a first-stage thermostat demand.

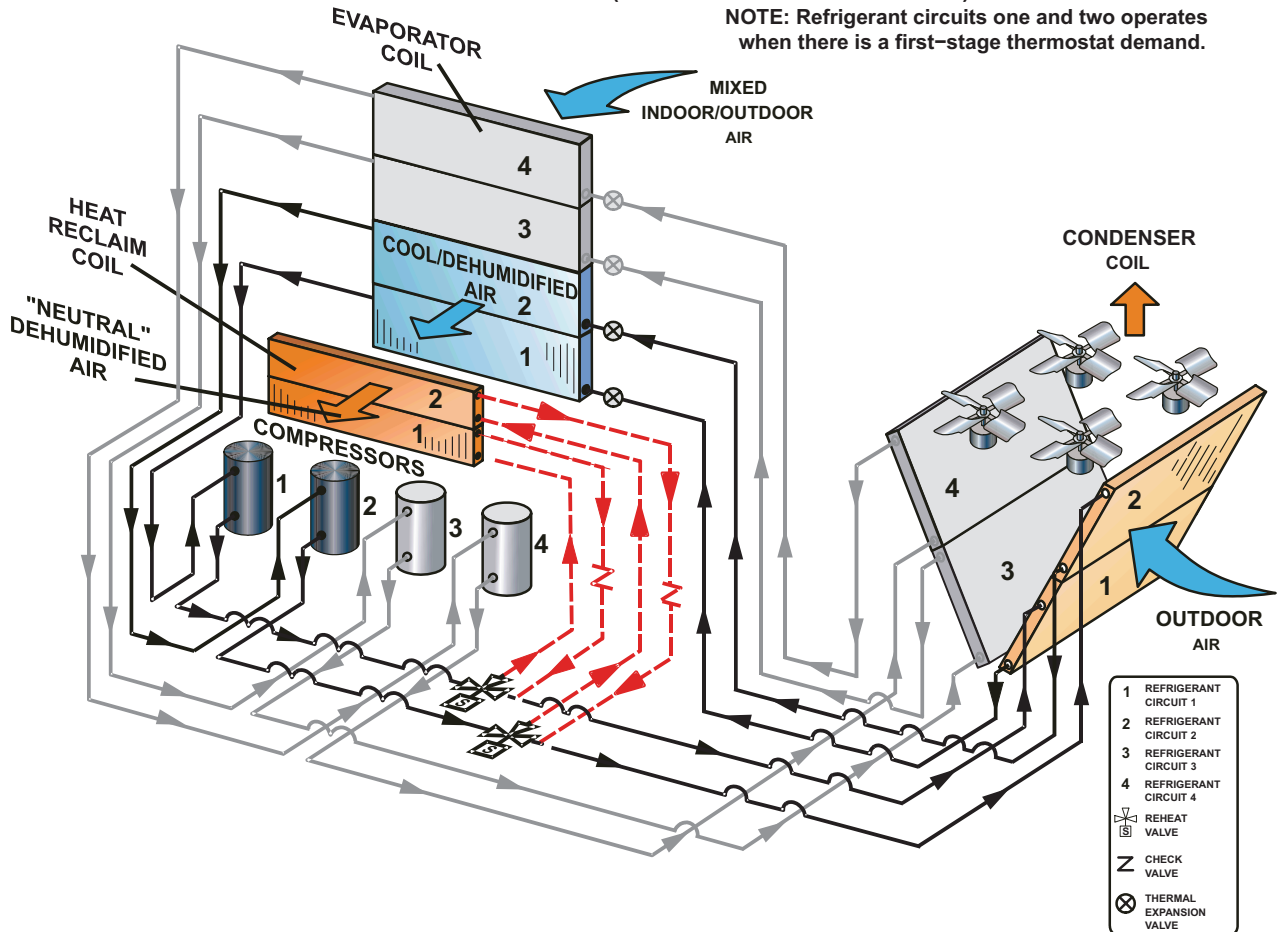

OPTIONAL CONVENTIONAL TEMPERATURE CONTROL SYSTEMS

CS8500 Commercial 7-Day Programmable Thermostat

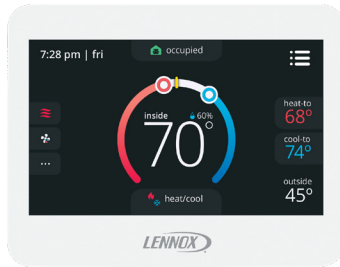

- Fully Communicating Sensor
- Full Color Touchscreen Interface
- Variable Speed System Control (On Compatible Units)
- Up To 4 Heat / 4 Cool
- Built-In Sensors For Temperature, Humidity And Optional CO₂
- Remote Sensor Options For Occupancy, Temperature
- BACnet Capable Options
- 5-2 or 7-Day Scheduling
- Smooth Setback Recovery
- Heat/Cool Auto-Changeover
- Four-Wire Installation
- FDD, ASHRAE, IECC Compliant

CS7500 Commercial 7-Day Programmable Thermostat



- Premium Universal Thermostat
- Full Color Touchscreen Interface
- Up To 4 Heat / 4 Cool
- Built-In Sensors For Temperature and Humidity
- Remote Sensors Options For Temperature, Discharge Air, Outdoor Air
- 5-2 or 7-Day Scheduling
- Smooth Setback Recovery
- Heat/Cool Auto-Changeover
- FDD, ASHRAE, IECC Compliant

CS3000 Commercial 5-2 Day Programmable Thermostat

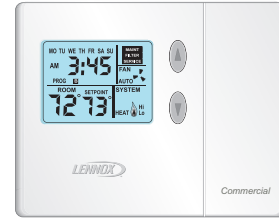

- Conventional Multi-Stage Thermostat
- Intuitive Display
- Push-Button Operation
- Up To 2 Heat / 2 Cool
- Built-In Temperature Sensor
- Remote Temperature Sensing
- Up to 5-2 Day Scheduling
- Smooth Setback Recovery
- Heat/Cool Auto-changeover

Wired Room Sensor (LCS-5030)



- Simple Push-Button Override
- Variable Speed System Control (On Compatible Units)
- Up To 4 Heat / 4 Cool
- Built-In Temperature and Humidity Sensors
- AA Battery / 24VAC Powered
- SBUS Wired Operation
- Automatic Sensor Averaging
- Locking Hex Screw

OPTIONAL CONVENTIONAL TEMPERATURE CONTROL SYSTEMS

Description	Catalog No.
CS8500 Commercial 7 Day Programmable Thermostat	
CS8500 7-Day Thermostat	No CO ₂ Sensing 17G75
	With CO ₂ Sensing 17G76
Sensors/Accessories	¹ Remote non-adjustable wall-mount 10k 47W37
	¹ Remote non-adjustable wall-mount 11k 94L61
Sysbus Network Cable (Yellow) for ComfortSense 8500 and LCS-5030 Wired Room Sensor	
Twisted pair 100% shielded communication cable, Red and Black	500 ft. box 27M19
22 AWG, yellow jacket, rated at 75°C, 300V, Plenum rated	1000 ft. box 94L63
Insulation - Low smoke PVC, NEC, CMP	2500 ft. roll 68M25
CS7500 Commercial 7-Day Programmable Thermostat	
CS7500 7-Day Thermostat	17G74
Sensors/Accessories	² Remote non-adjustable wall-mount 20k 47W36
	² Remote non-adjustable wall-mount 10k 47W37
	Remote non-adjustable discharge air (duct mount) 19L22
	Outdoor temperature sensor X2658
CS3000 Commercial 5-2 Day Programmable Thermostat	
CS3000 5-2 Day Thermostat	11Y05
Sensors/Accessories	Remote non-adjustable wall mount 10k averaging 47W37
	Thermostat wall mounting plate X2659
CS3000 Non-Programmable Thermostat	
CS3000 Non-Programmable Thermostat	51M32
Universal Thermostat Guard with Lock (clear)	
	Inside Dimensions (H x W) 5 7/8 x 8 3/8 in. 39P21
Wired Room Sensor	
LCS-5030 Wired Room Sensor	21L07

¹ Up to nine of the same type remote temperature sensors can be connected in parallel.

² Remote wall-mount sensors can be applied in any of the following combinations:
 One Sensor - (1) 47W36, Two Sensors - (2) 47W37, Three Sensors - (2) 47W36 and (1) 47W37
 Four Sensors - (4) 47W36, Five Sensors - (3) 47W36 and (2) 47W37

Objective: Outline the unit functions as a result of room thermostat or zone sensor demands.

Given: When economizer is present, it will function as an integral part of the unit cooling system. When not present, unit will function as if economizer is present but outdoor ambient is high and sensed as not suitable.

UNIT OPERATION WITH 2-STAGE THERMOSTAT (2 COOLING STAGES, Y1, Y2) - 3 AND 4 COMPRESSORS MODELS

SUPPLY AIR BLOWER SPEED

Unit has the following supply air blower speed settings:

- Ventilation speed
- Cooling speed - Low
- Cooling speed - High
- Heating speed
- Smoke speed (Used only in smoke removal option - not discussed)

¹ Unit Features An Economizer And Outdoor Air Is Suitable

Y1 Demand:

All compressors are off, supply air blower is on low cooling speed to minimize blower power consumption, economizer modulates (minimum to maximum open position) to maintain 55°F supply air temperature (default unit controller setting).

Y2 Demand:

All compressors are off, supply air blower is on high cooling speed providing higher cooling capacity, and economizer modulates to maintain 55°F supply air temperature.

If economizer stays at maximum open for 3 minutes, 1st stage compressors (compressor 1 and 2) are energized while supply air blower stays on high cooling speed providing maximum cooling capacity.

¹ *Outdoor air suitability is determined by the energy state of outdoor ambient (enthalpy or sensible) and its ability to achieve the desired free cooling effects. Outdoor air suitability can also be determined by a third party controller and provided to the RTU via a network connection.*

Unit Does Not Feature An Economizer Or Outdoor Air Is Not Suitable

Y1 Demand:

1st stage compressors operate and supply air blower operates at low cooling speed.

Y2 Demand:

All compressors operate and supply air blower operates at high cooling speed.

Dehumidification Mode

If a unit with Humiditrol® Dehumidification Option receives a call for dehumidification, economizer free cooling is locked out.

Call For Dehumidification, No Y1, Y2 Demand:

1st stage compressors (1 & 2) operate, supply air blower operates at high cooling speed, and the reheat valves are energized.

Y1 Demand With A Call For Dehumidification:

All compressors operate, supply air blower operates at high cooling speed and the reheat valves are energized.

Y2 Demand With A Call For Dehumidification:

All compressors operate, supply air blower operates at high cooling speed, and the reheat valves are de-energized.

UNIT WITH 3-STAGE THERMOSTAT (3 COOLING STAGES, Y1, Y2, Y3) - 3 AND 4 COMPRESSORS MODELS, OR ZONE SENSOR (4 COOLING STAGES, Y1, Y2, Y3, Y4) - 3 COMPRESSORS MODELS**SUPPLY AIR BLOWER SPEED**

Unit has following supply air blower speed setting:

- Ventilation speed
- Cooling speed - Low
- Cooling speed - Medium
- Cooling speed - High
- Heating speed
- Smoke speed (Used only in smoke removal option - not discussed)

¹ Unit Features An Economizer And Outdoor Air Is Suitable**3 Compressor Models****Y1 Demand:**

All compressors are off, supply air blower is on low cooling speed to minimize blower power consumption, economizer modulates (minimum to maximum open position) to maintain 55°F supply air temperature (default unit controller setting).

Y2 Demand:

All compressors are off, supply air blower is on high cooling speed providing higher cooling capacity, economizer modulates (minimum to maximum open position) to maintain 55°F supply air temperature (default unit controller setting).

If economizer stays at maximum open for 3 minutes then compressor 1 is energized while supply air blower stays on high cooling speed. After compressor is energized the economizer stays at maximum open.

Y3 Demand:

Compressors 1 and 2 are energized while supply air blower stays on high cooling speed. After compressors are energized the economizer stays at maximum.

Y4 (Zone Sensor Only) Demand:

All compressors are energized and supply air blower stays on high cooling speed.

4 Compressor Models**Y1 Demand:**

All compressors are off, supply air blower is on low cooling speed to minimize blower power consumption, economizer modulates (minimum to maximum open position) to maintain 55°F supply air temperature (default unit controller setting).

Y2 Demand:

All compressors are off, supply air blower is on high cooling speed providing higher cooling capacity, economizer modulates (minimum to maximum open position) to maintain 55°F supply air temperature (default unit controller setting).

If economizer stays at maximum open for 3 minutes then compressors 1 and 2 are energized while supply air blower stays on high cooling speed. After compressors are energized the economizer stays at maximum open.

Y3 Demand:

Compressors 1, 2 and 3 are energized and supply air blower stays on high cooling speed.

¹ Outdoor air suitability is determined by the energy state of outdoor ambient (enthalpy or sensible) and its ability to achieve the desired free cooling effects. Outdoor air suitability can also be determined by a third party controller and provided to the RTU via a network connection.

UNIT WITH 3-STAGE THERMOSTAT (3 COOLING STAGES, Y1, Y2, Y3) - 3 AND 4 COMPRESSORS MODELS, OR ZONE SENSOR (4 COOLING STAGES, Y1, Y2, Y3, Y4) - 3 COMPRESSORS MODELS (CONTINUED)**Unit Does Not Feature An Economizer Or Outdoor Air Is Not Suitable****3 Compressor Units****Y1 Demand:**

Compressor 1 operates and supply air blower operates at low cooling speed.

Y2 Demand:

Compressors 1 and 2 operate and supply air blower operates at medium cooling speed.

Y3 or Y4 (Zone Sensor Only) Demand:

All compressors operate and supply air blower operates at high cooling speed .

4 Compressor Units**Y1 Demand:**

Compressors 1 and 2 operate and supply air blower operates at low cooling speed.

Y2 demand:

Compressors 1, 2, and 3 operate and supply air blower operates at medium cooling speed.

Y3 demand:

All compressors operate and supply air blower operates at high cooling speed.

Dehumidification Mode

If a unit with Humiditrol® Dehumidification Option receives a call for dehumidification, economizer free cooling is locked out.

Call For Dehumidification, No Y1, Y2, Y3 Demand:

Compressor 1 and 2 operate, supply air blower operates at high cooling speed, and both reheat valves are energized.

Y1 Demand With A Call For Dehumidification:

All compressors operate, supply air blower operates at high cooling speed and both reheat valves are energized.

Y2 Demand With A Call For Dehumidification:

All compressors operate, supply air blower operates at high cooling speed, and the reheat valve of refrigeration circuit 1 is energized while the reheat valve of refrigeration circuit 2 is de-energized.

Y3 or Y4 (Zone Sensor Only) Demand:

All compressors operate, supply air blower operates at high cooling speed, and both reheat valves are de-energized.

UNIT WITH ZONE SENSOR (4 COOLING STAGES, Y1, Y2, Y3, Y4) – 4 COMPRESSORS MODELS**SUPPLY AIR BLOWER SPEED**

Unit has following supply air blower speed setting:

- Ventilation speed
- Cooling speed - Low
- Cooling speed - Medium-Low
- Cooling speed - Medium-High
- Cooling speed - High
- Heating speed
- Smoke speed (Used only in smoke removal option - not discussed)

¹ Unit Features An Economizer And Outdoor Air Is Suitable**Y1 Demand:**

All compressors are off, supply air blower is on low cooling speed to minimize blower power consumption, economizer modulates (minimum to maximum open position) to maintain 55°F supply air temperature (default unit controller setting).

Y2 Demand:

All compressors are off, supply air blower is on high cooling speed providing higher cooling capacity, and economizer modulates to maintain 55°F supply air temperature.

If economizer stays at maximum open for 3 minutes, compressor 1 is energized while supply air blower stays on high cooling speed. After compressor 1 is energized the economizer stays at maximum open.

Y3 Demand:

Compressor 1 and 2 are energized while supply air blower is on high cooling speed providing even higher cooling capacity.

Y4 Demand:

All compressors are energized while supply air blower is on high cooling speed providing maximum cooling capacity.

¹ Outdoor air suitability is determined by the energy state of outdoor ambient (enthalpy or sensible) and its ability to achieve the desired free cooling effects. Outdoor air suitability can also be determined by a third party controller and provided to the RTU via a network connection.

Unit Does Not Feature An Economizer Or Outdoor Air Is Not Suitable**Y1 demand:**

Compressor 1 operates and supply air blower operates at low cooling speed.

Y2 demand:

Compressors 1 and 2 operate and supply air blower operates at medium-low cooling speed.

Y3 demand:

Compressors 1, 2, and 3 operate and supply air blower operates at medium-high cooling speed.

Y4 demand:

All compressors operate and supply air blower operates at high cooling speed.

UNIT WITH ZONE SENSOR (4 COOLING STAGES, Y1, Y2, Y3, Y4) – 4 COMPRESSORS MODELS (CONTINUED)**Dehumidification Mode**

If a unit with Humiditrol® Dehumidification Option receives a call for dehumidification, economizer free cooling is locked out.

Call For Dehumidification, No Y1, Y2, Y3, Y4 Demand:

Compressors 1 and 2 operate, supply air blower operates at high cooling speed, and both reheat valves are energized.

Y1 Demand With A Call For Dehumidification:

Compressors 1, 2, and 3 operate, supply air blower operates at high cooling speed and both reheat valves are energized.

Y2 Demand With A Call For Dehumidification:

All compressors operate, supply air blower operates at high cooling speed, and both reheat valves are energized.

Y3 Demand With A Call For Dehumidification:

All compressors operate, supply air blower operates at high cooling speed, and the reheat valve of compressor 1 is energized while the reheat valve of compressor 2 is de-energized.

Y4 Demand With A Call For Dehumidification:

All compressors operate, supply air blower operates at high cooling speed, and the reheat valves are de-energized.

Heating Mode (Electric Heat)

NOTE - HEATING MODE IS THE SAME FOR ALL CONTROL OPTIONS.

W1 Demand:

1st stage electric heat is energized and the supply air blower operates at heating speed.

W2 Demand:

2nd stage electric heat is energized and the supply air blower operates at heating speed (45, 60 or 90 kW electric heat option only).

Modulating Outdoor Air Damper

The minimum damper position for “occupied low blower” and “occupied high blower” is adjusted during unit setup to provide minimum fresh air requirements per ASHRAE 62.1 at the corresponding supply air blower speeds.

- When supply air blower is off or the unit is in unoccupied mode, the outdoor air damper is closed.
- When unit is in occupied mode and supply air blower is operating at a speed below the “midpoint” blower speed, the outdoor air damper is at minimum “low blower” position.
- When unit is in occupied mode and supply air blower is operating at a speed equal to or above the “midpoint” blower speed, the outdoor air damper is at minimum “high blower” position.

NOTE - The “midpoint” blower speed is an average of the minimum and maximum blower speed (minimum speed + maximum speed divided by 2).

Power Exhaust Operation

NOTE - POWER EXHAUST OPERATION IS THE SAME FOR ALL CONTROL OPTIONS

MSAV® models are equipped with 2-stage power exhaust fans. Power exhaust fans operate when economizer outdoor air dampers are 50% open (adjustable). Power exhaust operates in 1st stage (one fan) up to 70% of supply air blower speed. 2nd stage power exhaust fans (both fans) operate when supply air blower speed is above 70% (adjustable) of full speed.

VAV UNITS IN ZONING APPLICATIONS OPERATING WITH DISCHARGE AIR CONTROL - 156/180 MODELS ONLY (4 HEAT / 3 COOL)**SUPPLY AIR BLOWER SPEED**

Unit has the following supply air blower speed settings:

- Ventilation Speed
- Cooling Speed - Fully modular based on supply duct static pressure
- Heating Speed
- Smoke Speed (Used only in smoke removal option - not discussed)

Cooling Mode (3 Cool)

- Discharge air temperature (DAT) can be used to control unit staging.
- DAT default setpoint = 55°F. Unit will stage compressors as required to maintain the setpoint when provided with Y1 thermostat demand.
- Increasing compressor stages provides more cooling capacity while decreasing compressor stages provides less cooling capacity.

¹ Unit Features An Economizer And Outdoor Air Is Suitable**Cooling Stage 1**

All compressors are off, supply air blower operates to maintain duct static pressure, economizer modulates (minimum to maximum open position) to maintain 55°F supply air temperature (default unit controller setting).

Cooling Stage 2

All compressors are off, supply air blower operates to maintain duct static pressure, and economizer modulates to maintain 55°F supply air temperature. If economizer stays at maximum open for 3 minutes, compressor 1 is energized while supply air blower operates to maintain duct static pressure. After compressor 1 is energized, the economizer stays at maximum open.

Cooling Stage 3

Compressor 1 and 2 are energized while supply air blower operates to maintain duct static pressure.

¹ Outdoor air suitability is determined by the energy state of outdoor ambient (enthalpy or sensible) and its ability to achieve the desired free cooling effects. Outdoor air suitability can also be determined by a third party controller and provided to the RTU via a network connection.

Unit Does Not Feature An Economizer Or Outdoor Air Is Not Suitable**Cooling Stage 1**

Compressor 1 operates and supply air blower operates to maintain duct static pressure.

Cooling Stage 2

Compressors 1 and 2 operate and supply air blower operates to maintain duct static pressure.

Cooling Stage 3

Compressors 1, 2, and 3 operate and supply air blower operates to maintain duct static pressure.

Heating Mode (4 Heat)

- Room sensors (when connected to S-Bus) or Discharge air temperature (DAT) can be used to control up to four stages of electric heat.
- DAT default setpoint = 110°F. Unit will stage heating as required to maintain the setpoint when provided with W1 demand.
- Room sensor occupied setpoint default = 70°F. Unit will stage heating as required to maintain the setpoint.
- Increasing heat stages provides more heating capacity while decreasing heat stages provides less heating capacity.
- Blower set to Heating Speed for all stages.

**VAV UNITS IN ZONING APPLICATIONS OPERATING WITH DISCHARGE AIR CONTROL - 240 MODELS ONLY
(4 HEAT / 4 COOL)****SUPPLY AIR BLOWER SPEED**

Unit has the following supply air blower speed settings:

- Ventilation Speed
- Cooling Speed - Fully modular based on supply duct static pressure
- Heating Speed
- Smoke Speed (Used only in smoke removal option - not discussed)

Cooling Mode (4 Cool)

- Discharge air temperature (DAT) can be used to control unit staging.
- DAT default setpoint = 55°F. Unit will stage compressors as required to maintain the setpoint when provided with Y1 thermostat demand.
- Increasing compressor stages provides more cooling capacity while decreasing compressor stages provides less cooling capacity.

¹ Unit Features An Economizer And Outdoor Air Is Suitable**Cooling Stage 1**

All compressors are off, supply air blower operates to maintain duct static pressure, economizer modulates (minimum to maximum open position) to maintain 55°F supply air temperature (default unit controller setting).

Cooling Stage 2

All compressors are off, supply air blower operates to maintain duct static pressure, and economizer modulates to maintain 55°F supply air temperature. If economizer stays at maximum open for 3 minutes, compressor 1 is energized while supply air blower operates to maintain duct static pressure. After compressor 1 is energized, the economizer stays at maximum open.

Cooling Stage 3

Compressor 1 and 2 are energized while supply air blower operates to maintain duct static pressure.

Cooling Stage 4

All compressors are energized while supply air blower operates to maintain duct static pressure.

¹ Outdoor air suitability is determined by the energy state of outdoor ambient (enthalpy or sensible) and its ability to achieve the desired free cooling effects. Outdoor air suitability can also be determined by a third party controller and provided to the RTU via a network connection.

Unit Does Not Feature An Economizer Or Outdoor Air Is Not Suitable**Cooling Stage 1**

Compressor 1 operates and supply air blower operates to maintain duct static pressure.

Cooling Stage 2

Compressors 1 and 2 operate and supply air blower operates to maintain duct static pressure.

Cooling Stage 3

Compressors 1, 2, and 3 operate and supply air blower operates to maintain duct static pressure.

Cooling Stage 4

All compressors operate and supply air blower operates to maintain duct static pressure.

Heating Mode (4 Heat)

- Room sensors (when connected to S-Bus) or Discharge air temperature (DAT) can be used to control up to four stages of electric heat.
- DAT default setpoint = 110°F. Unit will stage heating as required to maintain the setpoint when provided with W1 demand.
- Room sensor occupied setpoint default = 70°F. Unit will stage heating as required to maintain the setpoint.
- Increasing heat stages provides more heating capacity while decreasing heat stages provides less heating capacity.
- Blower set to Heating Speed for all stages.

VAV UNITS IN ZONING APPLICATIONS OPERATING WITH DISCHARGE AIR CONTROL (4 HEAT / 4 COOL)
(CONTINUED)**Modulating Outdoor Air Damper**

The minimum damper position for “occupied low blower” and “occupied high blower” is adjusted during unit setup to provide minimum fresh air requirements per ASHRAE 62.1 at the corresponding supply air blower speeds. When supply air blower is off or the unit is in unoccupied mode, the outdoor air damper is closed.

When unit is in occupied mode and supply air blower is operating at a speed below the “midpoint” blower speed, the outdoor air damper is at minimum “low blower” position.

When unit is in occupied mode and supply air blower is operating at a speed equal to or above the “midpoint” blower speed, the outdoor air damper is at minimum “high blower” position.

NOTE - The “midpoint” blower speed is an average of the minimum and maximum blower speed ((minimum speed + maximum speed) divided by 2).

OPTIONS / ACCESSORIES

Item Description	Catalog Number	Unit Model No					
		156	180	210	240	300	
COOLING SYSTEM							
Condensate Drain Trap	PVC	22H54	OX	OX	OX	OX	OX
	Copper	76W27	X	X	X	X	X
Conventional Fin/Tube Condenser Coil (replaces Environ™ Coil System)	Factory		O	O	O	O	O
Corrosion Protection	Factory		O	O	O	O	O
Drain Pan Overflow Switch	21Z07		OX	OX	OX	OX	OX
Efficiency	High		O	O	O	O	
	Standard						O
Refrigerant Type	R-410A		O	O	O	O	O
Service valves (not for Environ™ Coil System or Humiditrol® Dehumidification)	Factory		O	O	O	O	O
BLOWER - SUPPLY AIR							
Blower Option	CAV (Constant Air Volume)	Factory	O	O	O	O	O
	VAV (Variable Air Volume) supply air blower option (Without VFD Bypass Control)	Factory	O	O		O	
	MSAV® Multi-Stage Air Volume supply air blower option (With VFD Bypass Control)	Factory	O	O	O	O	O
	MSAV® Multi-Stage Air Volume supply air blower option (Without VFD Bypass Control)	Factory	O	O	O	O	O
Motors - CAV (Constant Air Volume)	Belt Drive (standard efficiency) - 2 hp	Factory	O				
	Belt Drive (standard or high efficiency) - 3 hp	Factory	O	O	O		
	Belt Drive (standard efficiency) - 5 hp	Factory	O	O	O	O	O
	Belt Drive (standard efficiency) - 7.5 hp	Factory		O	O	O	O
	Belt Drive (standard efficiency) - 10 hp	Factory				O	O
Motors - VAV (Variable Air Volume)	Belt Drive (standard or high efficiency) - 2 hp	Factory	O				
	Belt Drive (standard or high efficiency) - 3 hp	Factory	O	O			
	Belt Drive (standard efficiency) - 5 hp	Factory	O	O		O	
	Belt Drive (standard efficiency) - 7.5 hp	Factory		O		O	
	Belt Drive (standard efficiency) - 10 hp	Factory				O	
Motors - MSAV® Multi-Stage Air Volume	Belt Drive (standard efficiency) - 2 hp	Factory	O				
	Belt Drive (standard efficiency) - 3 hp	Factory	O	O	O		
	Belt Drive (standard efficiency) - 5 hp	Factory	O	O	O	O	O
	Belt Drive (standard efficiency) - 7.5 hp	Factory		O	O	O	O
	Belt Drive (standard efficiency) - 10 hp	Factory				O	O
Drive Kits See Blower Data Tables for usage and selection	Kit #1 535-725 rpm	Factory	O	O	O		
	Kit #2 710-965 rpm	Factory	O	O	O		
	Kit #3 685-856 rpm	Factory	O	O	O	O	O
	Kit #4 850-1045 rpm	Factory	O	O	O	O	O
	Kit #5 945-1185 rpm	Factory	O	O	O	O	O
	Kit #6 850-1045 rpm	Factory		O	O	O	O
	Kit #7 945-1185 rpm	Factory		O	O	O	O
	Kit #8 1045-1285 rpm	Factory		O	O	O	O
	Kit #10 1045-1285 rpm	Factory				O	O
	Kit #11 1135-1365 rpm	Factory				O	O
	Blower Belt Auto-Tensioner	Factory	O	O	O	O	O
CABINET							
Combination Coil/ Hail Guards	Environ™ Coil System	15T92	X				
		15T93		X	X	X	X
	Conventional Fin/Tube Condenser Coil	13T08	X				
		13T12		X	X	X	X

NOTE - Catalog numbers shown are for ordering field installed accessories.

OX = Configure To Order (Factory Installed) or Field Installed.

O = Configure To Order (Factory Installed).

X = Field Installed.

OPTIONS / ACCESSORIES

Item Description	Catalog Number	Unit Model No					
		156	180	210	240	300	
CONTROLS							
Blower Proving Switch		21Z10	OX	OX	OX	OX	OX
Commercial Controls	BACnet® Module	59W51	OX	OX	OX	OX	OX
	LonTalk® Module	54W27	OX	OX	OX	OX	OX
	Novar® LSE	Factory	O	O	O	O	O
Dirty Filter Switch		53W68	OX	OX	OX	OX	OX
Fresh Air Tempering		58W63	OX	OX	OX	OX	OX
General Purpose Control Kit		13J78	X	X	X	X	X
Smoke Detector - Supply or Return (Power board and one sensor)		22H56	OX	OX	OX	OX	OX
Smoke Detector - Supply and Return (Power board and two sensors)		22H57	OX	OX	OX	OX	OX
INDOOR AIR QUALITY							
Air Filters							
Healthy Climate® High Efficiency Air Filters 24 x 24 x 2 (Order 6 per unit)	MERV 8	54W67	OX	OX	OX	OX	OX
	MERV 13	52W40	OX	OX	OX	OX	OX
	MERV 16	21U42	OX	OX	OX	OX	OX
Replacement Media Filter With Metal Mesh Frame (includes non-pleated filter media)		44N61	OX	OX	OX	OX	OX
Indoor Air Quality (CO₂) Sensors							
Sensor - Wall-mount, off-white plastic cover with LCD display		77N39	X	X	X	X	X
Sensor - Wall-mount, off-white plastic cover, no display		87N53	X	X	X	X	X
Sensor - Black plastic case with LCD display, rated for plenum mounting		87N52	X	X	X	X	X
Sensor - Wall-mount, black plastic case, no display, rated for plenum mounting		87N54	X	X	X	X	X
CO ₂ Sensor Duct Mounting Kit - for downflow applications		85L43	X	X	X	X	X
Aspiration Box - for duct mounting non-plenum rated CO ₂ sensors (87N53 or 77N39)		90N43	X	X	X	X	X
Needlepoint Bipolar Ionization (NPBI)							
Needlepoint Bipolar Ionization (NPBI) Kit		21U37	X	X	X		
		21U38				X	
		21U39					X
UVC Germicidal Light Kit							
¹ Healthy Climate® UVC Light Kit (110/230v-1ph)		21A94	X	X	X	X	X
Step-Down Transformers	460V primary, 230V secondary	10H20	X	X	X	X	X
	575V primary, 230V secondary	10H21	X	X	X	X	X
ELECTRICAL							
Voltage 60 Hz	208/230V - 3 phase	Factory	O	O	O	O	O
	460V - 3 phase	Factory	O	O	O	O	O
	575V - 3 phase	Factory	O	O	O	O	O
Disconnect Switch (see Electric Heat Tables for usage,	80 amp	54W85	OX	OX	OX	OX	OX
	150 amp	54W86	OX	OX	OX	OX	OX
	250 amp	54W87	OX	OX	OX	OX	OX
² Short-Circuit Current Rating (SCCR) of 100kA (includes Phase/Voltage Detection)		Factory	O	O	O	O	O
GFI Service Outlets	15 amp non-powered, field-wired (208/230V, 460V only)	74M70	OX	OX	OX	OX	OX
	15 amp factory-wired and powered (208/230V, 460V only)	Factory	O	O	O	O	O
	³ 20 amp non-powered, field-wired (208/230V, 460V, 575V)	67E01	X	X	X	X	X
	³ 20 amp non-powered, field-wired (575V)	Factory	O	O	O	O	O
Weatherproof Cover for GFI		10C89	X	X	X	X	X
Phase/Voltage Detection (Optional for CAV options only, furnished with VAV or MSAV® Multi-Stage Air Volume option)		Factory	O	O	O	O	O

¹ Lamps operate on 110-230V single-phase power supply. Step-down transformer may be ordered separately for 460V and 575V units. Alternately, 110V power supply may be used to directly power the UVC ballast(s).

² Disconnect Switch not available with higher SCCR option. Short-Circuit Current Rating option not available on field installed electric heat or 90kW electric heat (208/240V) models.

³ Canada requires a minimum 20 amp circuit. Select 20 amp, non-powered, field wired GFI.

NOTE - Catalog numbers shown are for ordering field installed accessories.

OX = Configure To Order (Factory Installed) or Field Installed.

O = Configure To Order (Factory Installed).

X = Field Installed.

OPTIONS / ACCESSORIES

Item Description	Catalog Number	Unit Model No					
		156	180	210	240	300	
ELECTRIC HEAT							
15 kW	208/230V-3ph	22H66	OX	OX	OX	OX	OX
	460V-3ph	22H67	OX	OX	OX	OX	OX
	575V-3ph	22V35	OX	OX	OX	OX	OX
30 kW	208/230V-3ph	22H68	OX				
	460V-3ph	22H69	OX				
	575V-3ph	22V36	OX				
	208/230V-3ph	22H70		OX	OX	OX	OX
	460V-3ph	22H71		OX	OX	OX	OX
	575V-3ph	22V37		OX	OX	OX	OX
45 kW	208/230V-3ph	22H72	OX				
	460V-3ph	22H73	OX				
	575V-3ph	22V38	OX				
	208/230V-3ph	22H74		OX	OX	OX	OX
	460V-3ph	22H75		OX	OX	OX	OX
	575V-3ph	22V39		OX	OX	OX	OX
60 kW	208/230V-3ph	22H76	OX				
	460V-3ph	22H77	OX				
	575V-3ph	22V40	OX				
	208/230V-3ph	22H78		OX	OX	OX	OX
	460V-3ph	22H79		OX	OX	OX	OX
	575V-3ph	22V41		OX	OX	OX	OX
90 kW	208/230V-3ph	22H80			OX	OX	OX
	460V-3ph	22H81			OX	OX	OX
	575V-3ph	22V42			OX	OX	OX
	SCR (Silicon Controlled Rectifier) Electric Heat Control NOTE - The SCR option is not available with 45 kW, 60 kW and 90kW electric heat (208/230V) models.	Factory		O	O	O	O
Thermostat (required)	Y9682		X	X	X	X	X
Duct Sensor (required)	Y9683		X	X	X	X	X
ECONOMIZER							
High Performance Economizer (Approved for California Title 24 Building Standards / AMCA Class 1A Certified)							
High Performance Economizer Downflow or Horizontal - Includes Outdoor Air Hood. Order Downflow or Horizontal Barometric Relief Dampers separately.	E1ECON17C-2	22J18	OX	OX	OX	OX	OX
Economizer Controls							
Differential Enthalpy (Not for Title 24)	Order 2	21Z09	OX	OX	OX	OX	OX
Sensible Control	Sensor is Furnished	Factory	O	O	O	O	O
Single Enthalpy (Not for Title 24)		21Z09	OX	OX	OX	OX	OX
Global Control	Sensor Field Provided	Factory	O	O	O	O	O
Building Pressure Control		13J77	X	X	X	X	X
Outdoor Air CFM Control		13J76	X	X	X	X	X
Barometric Relief Dampers With Exhaust Hood							
Downflow Barometric Relief Dampers		54W78	OX	OX	OX	OX	OX
Horizontal Barometric Relief Dampers		16K99	X	X	X	X	X
OUTDOOR AIR							
Outdoor Air Dampers With Outdoor Air Hood							
Motorized		22J27	OX	OX	OX	OX	OX
Manual		13U05	OX	OX	OX	OX	OX

NOTE - Catalog numbers shown are for ordering field installed accessories.

OX = Configure To Order (Factory Installed) or Field Installed.

O = Configure To Order (Factory Installed).

X = Field Installed.

OPTIONS / ACCESSORIES

Item Description	Catalog Number	Unit Model No					
		156	180	210	240	300	
² POWER EXHAUST (DOWNFLOW APPLICATIONS ONLY)							
Standard Static, SCCR Rated	208/230V	22H90	OX	OX	OX	OX	OX
	460V	22H91	OX	OX	OX	OX	OX
	575V	22V34	OX	OX	OX	OX	OX
HUMIDITROL® CONDENSER REHEAT OPTION (CAV AND MSAV®) MODELS ONLY							
Humiditrol® Dehumidification Option	Factory		O	O	O	O	O
Humidity Sensor Kit, Remote mounted (required)	17M50	X	X	X	X	X	X
ROOF CURBS							
Hybrid Roof Curbs, Downflow							
8 in. height		11F58	X	X	X	X	X
14 in. height		11F59	X	X	X	X	X
18 in. height		11F60	X	X	X	X	X
24 in. height		11F61	X	X	X	X	X
Adjustable Pitch Curb							
14 in. height		43W26	X	X	X	X	X
Standard Roof Curbs, Horizontal - Requires Horizontal Return Air Panel Kit							
26 in. height - slab applications		11T89	X	X	X	X	
30 in. height - slab applications		11T90					X
37 in. height - rooftop applications		11T96	X	X	X	X	
41 in. height - rooftop applications		11T97					X
Insulation Kit For Standard Horizontal Roof Curbs							
For 26 in. Curb		73K32	X	X	X	X	
For 30 in. Curb		73K33					X
For 37 in. Curb		73K34	X	X	X	X	
For 41 in. Curb		73K35					X
Horizontal Return Air Panel Kit							
Required for Horizontal Applications with Roof Curb		87M00	X	X	X	X	X
CEILING DIFFUSERS							
Step-Down - Order one	RTD11-185S	13K63	X	X			
	RTD11-275S	13K64			X	X	X
Flush - Order one	FD11-185S	13K58	X	X			
	FD11-275S	13K59			X	X	X
Transitions (Supply and Return) - Order one	C1DIFF33C-1	12X68	X	X			
	C1DIFF34C-1	12X70			X	X	X

¹ Field installed Power Exhaust requires Economizer with Outdoor Air Hood and Downflow Barometric Relief Dampers with Exhaust Hood. Must be ordered separately.

NOTE - Catalog numbers shown are for ordering field installed accessories.

OX = Configure To Order (Factory Installed) or Field Installed.

O = Configure To Order (Factory Installed).

X = Field Installed.

SPECIFICATIONS

General Data		Nominal Tonnage	13 Ton	13 Ton	13 Ton	
Model Number			LCH156H4B	LCH156H4V	LCH156H4M	
Efficiency Type			High	High	High	
Blower Type			CAV	VAV	MSAV®	
			Constant Air Volume	Variable Air Volume	Multi-Stage Air Volume	
Cooling Performance	Gross Cooling Capacity - Btuh		154,000	152,000	154,000	
	¹ Net Cooling Capacity - Btuh		150,000	148,000	150,000	
	AHRI Rated Air Flow - cfm		5000	4600	5000	
	Total Unit Power - kW		12.5	12.3	12.5	
	¹ EER (Btuh/Watt)		12.0	12.0	12.0	
	² IEER (Btuh/Watt)		13.2	14.5	14.1	
Refrigerant Charge	Refrigerant Type		R-410A	R-410A	R-410A	
Environ™ Coil System	Circuit 1	5 lbs. 12 oz.	5 lbs. 0 oz.	5 lbs. 12 oz.		
		Circuit 2	5 lbs. 4 oz.	5 lbs. 8 oz.	5 lbs. 4 oz.	
		Circuit 3	5 lbs. 10 oz.	5 lbs. 0 oz.	5 lbs. 10 oz.	
	Environ™ Coil System with Humiditrol®	Circuit 1	5 lbs. 14 oz.	---	5 lbs. 14 oz.	
		Circuit 2	5 lbs. 8 oz.	---	5 lbs. 8 oz.	
		Circuit 3	5 lbs. 12 oz.	---	5 lbs. 12 oz.	
	Conventional Fin/Tube Coil Option	Circuit 1	10 lbs. 0 oz.	---	10 lbs. 0 oz.	
		Circuit 2	10 lbs. 0 oz.	---	10 lbs. 0 oz.	
		Circuit 3	9 lbs. 8 oz.	---	9 lbs. 8 oz.	
	Conventional Fin/Tube With Humiditrol®	Circuit 1	12 lbs. 0 oz.	---	12 lbs. 0 oz.	
		Circuit 2	12 lbs. 0 oz.	---	12 lbs. 0 oz.	
		Circuit 3	9 lbs. 8 oz.	---	9 lbs. 8 oz.	
	Electric Heat (kW) Available - See page 26			15-30-45-60		
	Compressor Type (number)			Scroll (3)		
	Outdoor Coils	Net face area (total) - sq. ft.		41.4	41.4	41.4
Environ™ (Fin/Tube) Number of rows			1 (2)	1 (2)	1 (2)	
Fins per inch			23 (20)	23 (20)	23 (20)	
Outdoor Coil Fans	Motor - (No.) horsepower		(3) 1/3	(3) 1/3	(3) 1/3	
	Motor rpm		1075	1075	1075	
	Total Motor watts		1100	1100	1100	
	Diameter - (No.) in.		(3) 24	(3) 24	(3) 24	
	Number of blades		3	3	3	
	Total Air volume - cfm		12,000	12,000	12,000	
Indoor Coils	Net face area (total) - sq. ft.		21.4	21.4	21.4	
	Tube diameter - in.		3/8	3/8	3/8	
	Number of rows		3	3	3	
	Fins per inch		14	14	14	
	Drain connection - No. and size		(1) 1 in. FPT	(1) 1 in. FPT	(1) 1 in. FPT	
Expansion device type		Balance port TXV, removable head				
³ Indoor Blower and Drive Selection	Nominal motor output	2 hp, 3 hp, 5 hp				
	Max. usable motor output (US)	2.3 hp, 3.45 hp, 5.75 hp				
	Motor - Drive kit number	2 hp Kit 1 535-725 rpm Kit 2 710-965 rpm 3 hp Std. Eff. Kit 1 535-725 rpm Kit 2 710-965 rpm 3 hp High. Eff. Kit 3 685-856 rpm Kit 4 850-1045 rpm 5 hp Kit 3 - 685-856 rpm Kit 4 850-1045 rpm Kit 5 945-1185 rpm				
	Blower wheel nominal D x W - in.	(2) 15 x 15 in.	(2) 15 x 15 in.	(2) 15 x 15 in.		
	Filters	Type of filter	Fiberglass, disposable			
		Number and size - in.	(6) 24 x 24 x 2			
	Electrical characteristics		208/230V, 460V or 575V - 60 hertz - 3 phase			

NOTE - Net capacity includes evaporator blower motor heat deduction. Gross capacity does not include evaporator blower motor heat deduction.

¹ AHRI Certified to AHRI Standard 340/360; 95°F outdoor air temperature and 80°F db/67°F wb entering evaporator air; minimum external duct static pressure.

² Integrated Energy Efficiency Ratio tested according to AHRI Standard 340/360.

³ Using total air volume and system static pressure requirements determine from blower performance tables rpm and motor output required. Maximum usable output of motors furnished are shown. In Canada, nominal motor output is also maximum usable motor output. If motors of comparable output are used, be sure to keep within the service factor limitations outlined on the motor nameplate.

NOTE - Units equipped with MSAV® Multi-Stage Air Volume option are limited to a motor service factor of 1.0.

SPECIFICATIONS

General Data		Nominal Tonnage	15 Ton	15 Ton	15 Ton	17.5 Ton	17.5 Ton	
		Model Number	LCH180H4B	LCH180H4V	LCH180H4M	LCH210H4B	LCH210H4M	
		Efficiency Type	High	High	High	High	High	
		Blower Type	CAV	VAV	MSAV®	CAV	MSAV®	
			Constant Air Volume	Variable Air Volume	Multi-Stage Air Volume	(Constant Air Volume)	Multi-Stage Air Volume	
Cooling Performance	Gross Cooling Capacity - Btuh		176,000	176,000	176,000	204,000	204,000	
	¹ Net Cooling Capacity - Btuh		172,000	172,000	172,000	198,000	198,000	
	AHRI Rated Air Flow - cfm		5250	5250	5250	6125	6125	
	Total Unit Power - kW		14.3	14.3	14.3	16.5	16.5	
	¹ EER (Btuh/Watt)		12.0	12.0	12.0	12.0	12.0	
	² IEER (Btuh/Watt)		13.5	15.2	13.7	13.0	14.0	
Refrigerant Charge	Refrigerant Type		R-410A	R-410A	R-410A	R-410A	R-410A	
	Environ™ Coil System	Circuit 1	6 lbs. 0 oz.	5 lbs. 4 oz.	6 lbs. 0 oz.	6 lbs. 12 oz.	6 lbs. 12 oz.	
		Circuit 2	5 lbs. 10 oz.	5 lbs. 8 oz.	5 lbs. 10 oz.	6 lbs. 14 oz.	6 lbs. 14 oz.	
		Circuit 3	5 lbs. 14 oz.	5 lbs. 8 oz.	5 lbs. 14 oz.	6 lbs. 14 oz.	6 lbs. 14 oz.	
	Environ™ Coil System with Humiditrol®	Circuit 1	6 lbs. 8 oz.	---	6 lbs. 8 oz.	7 lbs. 4 oz.	7 lbs. 4 oz.	
		Circuit 2	5 lbs. 12 oz.	---	5 lbs. 12 oz.	7 lbs. 0 oz.	7 lbs. 0 oz.	
		Circuit 3	6 lbs. 9 oz.	---	6 lbs. 9 oz.	6 lbs. 4 oz.	6 lbs. 4 oz.	
	Conventional Fin/Tube Coil Option	Circuit 1	12 lbs. 8 oz.	---	12 lbs. 8 oz.	13 lbs. 0 oz.	13 lbs. 0 oz.	
		Circuit 2	12 lbs. 8 oz.	---	12 lbs. 8 oz.	13 lbs. 0 oz.	13 lbs. 0 oz.	
		Circuit 3	12 lbs. 8 oz.	---	12 lbs. 8 oz.	13 lbs. 0 oz.	13 lbs. 0 oz.	
	Conventional Fin/Tube With Humiditrol®	Circuit 1	14 lbs. 8 oz.	---	14 lbs. 8 oz.	15 lbs. 0 oz.	15 lbs. 0 oz.	
		Circuit 2	14 lbs. 8 oz.	---	14 lbs. 8 oz.	15 lbs. 0 oz.	15 lbs. 0 oz.	
		Circuit 3	12 lbs. 8 oz.	---	12 lbs. 8 oz.	13 lbs. 0 oz.	13 lbs. 0 oz.	
	Electric Heat (kW) Available - See page 26			15-30-45-60 kW			15-30-45-60-90 kW	
	Compressor Type (number)			Scroll (3)	Scroll (3)	Scroll (3)	Scroll (3)	Scroll (3)
	Outdoor Coils	Net face area (total) - sq. ft.		55.2	55.2	55.2	55.2	55.2
		Environ™ (Fin/Tube)	Number of rows	1 (2)	1 (2)	1 (2)	1 (2)	1 (2)
	Fins per inch		23 (20)	23 (20)	23 (20)	23 (20)	23 (20)	
Outdoor Coil Fans	Motor - (No.) horsepower		(4) 1/3	(4) 1/3	(4) 1/3	(6) 1/3	(6) 1/3	
	Motor rpm		1075	1075	1075	1075	1075	
	Total Motor watts		1500	1500	1500	1950	1950	
	Diameter - (No.) in.		(4) 24	(4) 24	(4) 24	(6) 24	(6) 24	
	Number of blades		3	3	3	3	3	
	Total Air volume - cfm		16,000	16,000	16,000	20,000	20,000	
	Drain connection - No. and size		(1) 1 in. FPT	(1) 1 in. FPT	(1) 1 in. FPT	(1) 1 in. FPT	(1) 1 in. FPT	
Expansion device type		Balance port TXV, removable head						
³ Indoor Blower and Drive Selection	Nominal motor output		3 hp, 5 hp, 7.5 hp					
	Max. usable motor output (US)		3.45 hp, 5.75 hp, 8.62 hp					
	Motor - Drive kit number		3 hp Std. Eff. Kit 1 535-725 rpm Kit 2 710-965 rpm 3 hp High. Eff. Kit 3 - 685-856 rpm Kit 4 850-1045 rpm 5 hp Kit 3 685-856 rpm Kit 4 850-1045 rpm Kit 5 945-1185 rpm 7.5 hp Kit 6 850-1045 rpm Kit 7 945-1185 rpm Kit 8 1045-1285 rpm					
	Blower wheel nominal D x W - in.		(2) 15 x 15					
	Filters	Type of filter		Fiberglass, disposable				
		Number and size - in.		(6) 24 x 24 x 2				
	Electrical characteristics			208/230V, 460V or 575V - 60 hertz - 3 phase				

NOTE - Net capacity includes evaporator blower motor heat deduction. Gross capacity does not include evaporator blower motor heat deduction.

¹ AHRI Certified to AHRI Standard 340/360; 95°F outdoor air temperature and 80°F db/67°F wb entering evaporator air; minimum external duct static pressure.

² Integrated Energy Efficiency Ratio tested according to AHRI Standard 340/360.

³ Using total air volume and system static pressure requirements determine from blower performance tables rpm and motor output required. Maximum usable output of motors furnished are shown. In Canada, nominal motor output is also maximum usable motor output. If motors of comparable output are used, be sure to keep within the service factor limitations outlined on the motor nameplate.

NOTE – Units equipped with MSAV® Multi-Stage Air Volume option are limited to a motor service factor of 1.0.

SPECIFICATIONS

General Data		Nominal Tonnage	20 Ton	20 Ton	20 Ton
		Model Number	LCH240H4B	LCH240H4V	LCH240H4M
		Efficiency Type	High	High	High
		Blower Type	CAV Constant Air Volume	VAV Variable Air Volume	MSAV® Multi-Stage Air Volume
Cooling Performance	Gross Cooling Capacity - Btuh		238,000	238,000	238,000
	¹ Net Cooling Capacity - Btuh		230,000	230,000	230,000
	AHRI Rated Air Flow - cfm		6400	6400	6400
	Total Unit Power - kW		19.2	19.2	19.2
	¹ EER (Btuh/Watt)		12.0	12.0	12.0
	² IEER (Btuh/Watt)		13.2	16.0	14.5
Refrigerant Charge	Refrigerant Type		R-410A	R-410A	R-410A
	Environ™ Coil System	Circuit 1	6 lbs. 4 oz.	6 lbs. 2 oz.	6 lbs. 4 oz.
		Circuit 2	6 lbs. 2 oz.	6 lbs. 6 oz.	6 lbs. 2 oz.
		Circuit 3	5 lbs. 14 oz.	6 lbs. 0 oz.	5 lbs. 14 oz.
		Circuit 4	5 lbs. 6 oz.	6 lbs. 10 oz.	5 lbs. 6 oz.
	Environ™ Coil System with Humiditrol®	Circuit 1	6 lbs. 4 oz.	---	6 lbs. 4 oz.
		Circuit 2	5 lbs. 10 oz.	---	5 lbs. 10 oz.
		Circuit 3	4 lbs. 14 oz.	---	4 lbs. 14 oz.
		Circuit 4	4 lbs. 14 oz.	---	4 lbs. 14 oz.
	Conventional Fin/Tube Coil Option	Circuit 1	10 lbs. 0 oz.	---	10 lbs. 0 oz.
		Circuit 2	10 lbs. 0 oz.	---	10 lbs. 0 oz.
		Circuit 3	10 lbs. 0 oz.	---	10 lbs. 0 oz.
		Circuit 4	8 lbs. 12 oz.	---	8 lbs. 12 oz.
	Conventional Fin/Tube With Humiditrol®	Circuit 1	12 lbs. 0 oz.	---	12 lbs. 0 oz.
		Circuit 2	12 lbs. 0 oz.	---	12 lbs. 0 oz.
		Circuit 3	10 lbs. 0 oz.	---	10 lbs. 0 oz.
Circuit 4		8 lbs. 12 oz.	---	8 lbs. 12 oz.	
Electric Heat (kW) Available - See page 26			15-30-45-60, 90 kW		
Compressor Type (number)			Scroll (4)	Scroll (4)	Scroll (4)
Outdoor Coils	Net face area (total) - sq. ft.		55.2	55.2	55.2
	Environ™ (Fin/Tube)	Number of rows	1 (2)	1 (2)	1 (2)
		Fins per inch	23 (20)	23 (20)	23 (20)
Outdoor Coil Fans	Motor - (No.) horsepower		(6) 1/3	(6) 1/3	(6) 1/3
	Motor rpm - Total Motor watts		1075 - 1950	1075 - 1950	1075 - 1950
	Diameter - (No.) in. - No. of blades		(6) 24 - 3	(6) 24 - 3	(6) 24 - 3
	Total Air volume - cfm		20,000	20,000	20,000
Indoor Coils	Net face area (total) - sq. ft.		21.4	21.4	21.4
	Tube diameter - in.		3/8	3/8	3/8
	Number of rows		4	4	4
	Fins per inch		14	14	14
	Drain connection - No. and size		(1) 1 in. FPT	(1) 1 in. FPT	(1) 1 in. FPT
Expansion device type			Balance port TXV, removable head		
³ Indoor Blower and Drive Selection	Nominal motor output		5 hp, 7.5 hp, 10 hp		
	Maximum usable motor output (US Only)		5.75 hp, 8.62 hp, 11.5 hp		
	Motor - Drive kit number		5 hp Kit 3 685-856 rpm Kit 4 850-1045 rpm Kit 5 945-1185 rpm 7.5 hp Kit 6 850-1045 rpm Kit 7 945-1185 rpm Kit 8 1045-1285 rpm 10 hp Kit 7 945-1185 rpm Kit 10 1045-1285 rpm Kit 11 1135-1365 rpm		
Blower wheel nom. D x W - in.		(2) 15 x 15			
Filters	Type of filter		Fiberglass, disposable		
	Number and size - in.		(6) 24 x 24 x 2		
Electrical characteristics			208/230V, 460V or 575V - 60 hertz - 3 phase		

NOTE - Net capacity includes evaporator blower motor heat deduction. Gross capacity does not include evaporator blower motor heat deduction.

¹ AHRI Certified to AHRI Standard 340/360; 95°F outdoor air temperature and 80°F db/67°F wb entering evaporator air; minimum external duct static pressure.

² Integrated Energy Efficiency Ratio tested according to AHRI Standard 340/360.

³ Using total air volume and system static pressure requirements determine from blower performance tables rpm and motor output required. Maximum usable output of motors furnished are shown. In Canada, nominal motor output is also maximum usable motor output. If motors of comparable output are used, be sure to keep within the service factor limitations outlined on the motor nameplate.

NOTE - Units equipped with MSAV® Multi-Stage Air Volume option are limited to a motor service factor of 1.0.

SPECIFICATIONS

General Data		Nominal Tonnage	25 Ton	25 Ton
		Model Number	LCH300S4B	LCH300S4M
		Efficiency Type	Standard	Standard
		Blower Type	CAV Constant Air Volume	MSAV® Multi-Stage Air Volume
Cooling Performance	Gross Cooling Capacity - Btuh		281,000	281,000
	¹ Net Cooling Capacity - Btuh		270,000	270,000
	AHRI Rated Air Flow - cfm		8400	8400
	Total Unit Power - kW		25.7	25.7
	¹ EER (Btuh/Watt)		10.5	10.5
	² IEER (Btuh/Watt)		11.6	13.8
Refrigerant Charge	Refrigerant Type		R-410A	R-410A
	Environ™ Coil System	Circuit 1	6 lbs. 4 oz.	6 lbs. 4 oz.
		Circuit 2	5 lbs. 10 oz.	5 lbs. 10 oz.
		Circuit 3	6 lbs. 6 oz.	6 lbs. 6 oz.
		Circuit 4	6 lbs. 0 oz.	6 lbs. 0 oz.
	Environ™ Coil System with Humiditrol®	Circuit 1	7 lbs. 8 oz.	7 lbs. 8 oz.
		Circuit 2	6 lbs. 4 oz.	6 lbs. 4 oz.
		Circuit 3	6 lbs. 2 oz.	6 lbs. 2 oz.
		Circuit 4	5 lbs. 14 oz.	5 lbs. 14 oz.
	Conventional Fin/Tube Coil Option	Circuit 1	10 lbs. 8 oz.	10 lbs. 8 oz.
		Circuit 2	10 lbs. 0 oz.	10 lbs. 0 oz.
		Circuit 3	9 lbs. 12 oz.	9 lbs. 12 oz.
		Circuit 4	9 lbs. 12 oz.	9 lbs. 12 oz.
	Conventional Fin/Tube With Humiditrol®	Circuit 1	12 lbs. 12 oz.	12 lbs. 12 oz.
		Circuit 2	11 lbs. 12 oz.	11 lbs. 12 oz.
		Circuit 3	9 lbs. 12 oz.	9 lbs. 12 oz.
Circuit 4		9 lbs. 12 oz.	9 lbs. 12 oz.	
Electric Heat (kW) Available - See page 26			15-30-45-60, 90 kW	
Compressor Type (number)			Scroll (4)	Scroll (4)
Outdoor Coils	Net face area (total) - sq. ft.		55.2	55.2
	Environ™ (Fin/Tube)	Number of rows Fins per inch	1 (2) 23 (20)	1 (2) 23 (20)
Outdoor Coil Fans	Motor - (No.) horsepower		(6) 1/3	(6) 1/3
	Motor rpm - Total Motor watts		1075 - 1950	1075 - 1950
	Diameter - (No.) in. - No. of blades		(6) 24 - 3	(6) 24 - 3
	Total Air volume - cfm		20,000	20,000
Indoor Coils	Net face area (total) - sq. ft.		21.4	21.4
	Tube diameter - in.		3/8	3/8
	Number of rows		4	4
	Fins per inch		14	14
	Drain connection - No. and size		(1) 1 in. FPT	(1) 1 in. FPT
	Expansion device type		Balance port TXV, removable head	
³ Indoor Blower and Drive Selection	Nominal motor output		5 hp, 7.5 hp, 10 hp	
	Maximum usable motor output (US Only)		5.75 hp, 8.62 hp, 11.5 hp	
	Motor - Drive kit number		5 hp Kit 3 685-856 rpm Kit 4 850-1045 rpm Kit 5 945-1185 rpm 7.5 hp Kit 6 850-1045 rpm Kit 7 945-1185 rpm Kit 8 1045-1285 rpm 10 hp Kit 7 945-1185 rpm Kit 10 1045-1285 rpm Kit 11 1135-1365 rpm	
	Blower wheel nom. D x W - in.		(2) 15 x 15	
Filters	Type of filter		Fiberglass, disposable	
	Number and size - in.		(6) 24 x 24 x 2	
Electrical characteristics			208/230V, 460V or 575V - 60 hertz - 3 phase	

NOTE - Net capacity includes evaporator blower motor heat deduction. Gross capacity does not include evaporator blower motor heat deduction.

¹ AHRI Certified to AHRI Standard 340/360; 95°F outdoor air temperature and 80°F db/67°F wb entering evaporator air; minimum external duct static pressure.

² Integrated Energy Efficiency Ratio tested according to AHRI Standard 340/360.

³ Using total air volume and system static pressure requirements determine from blower performance tables rpm and motor output required. Maximum usable output of motors furnished are shown. In Canada, nominal motor output is also maximum usable motor output. If motors of comparable output are used, be sure to keep within the service factor limitations outlined on the motor nameplate.

NOTE - Units equipped with MSAV® Multi-Stage Air Volume option are limited to a motor service factor of 1.0.

RATINGS

NOTE – For Temperatures and Capacities not shown in tables, see bulletin – Cooling Unit Rating Table Correction Factor Data in Miscellaneous Engineering Data section.

13 TON HIGH EFFICIENCY LCH156H4B (PART LOAD) - CONSTANT AIR VOLUME

Entering Wet Bulb Temperature	Total Air Volume	Outdoor Air Temperature Entering Outdoor Coil																			
		65°F					75°F					85°F					95°F				
		Total Cool Cap.	Comp. Motor Input	Sensible To Total Ratio (S/T)			Total Cool Cap.	Comp. Motor Input	Sensible To Total Ratio (S/T)			Total Cool Cap.	Comp. Motor Input	Sensible To Total Ratio (S/T)			Total Cool Cap.	Comp. Motor Input	Sensible To Total Ratio (S/T)		
				Dry Bulb					Dry Bulb					Dry Bulb					Dry Bulb		
cfm	kBtuh	kW	75°F	80°F	85°F	kBtuh	kW	75°F	80°F	85°F	kBtuh	kW	75°F	80°F	85°F	kBtuh	kW	75°F	80°F	85°F	
63°F	4160	110.6	4.68	0.67	0.80	0.93	103.7	5.30	0.68	0.81	0.95	96.4	5.97	0.68	0.82	0.97	88.8	6.74	0.68	0.84	0.99
	5200	117.9	4.73	0.72	0.87	0.99	110.4	5.34	0.72	0.88	1.00	102.7	6.01	0.73	0.90	1.00	94.7	6.78	0.74	0.93	1.00
	6240	123.1	4.77	0.76	0.93	1.00	115.4	5.38	0.77	0.95	1.00	107.5	6.05	0.79	0.97	1.00	99.3	6.81	0.80	0.99	1.00
67°F	4160	118.4	4.73	0.54	0.65	0.77	111.2	5.34	0.53	0.65	0.78	103.8	6.02	0.52	0.66	0.79	96.0	6.79	0.52	0.66	0.80
	5200	126.0	4.79	0.57	0.70	0.83	118.4	5.39	0.56	0.70	0.85	110.5	6.07	0.56	0.71	0.86	102.2	6.83	0.56	0.72	0.89
	6240	131.7	4.83	0.59	0.74	0.90	123.6	5.43	0.59	0.75	0.91	115.4	6.11	0.59	0.76	0.94	106.7	6.87	0.59	0.78	0.96
71°F	4160	126.1	4.78	0.42	0.53	0.63	118.8	5.39	0.40	0.52	0.63	111.2	6.07	0.39	0.52	0.63	103.1	6.84	0.37	0.51	0.64
	5200	134.1	4.84	0.43	0.55	0.67	126.1	5.45	0.41	0.55	0.68	118.0	6.13	0.4	0.55	0.69	109.6	6.89	0.39	0.55	0.70
	6240	140.0	4.88	0.44	0.58	0.72	131.7	5.49	0.42	0.58	0.73	123.3	6.17	0.42	0.59	0.74	114.3	6.93	0.40	0.59	0.76

13 TON HIGH EFFICIENCY LCH156H4B (FULL LOAD) - CONSTANT AIR VOLUME

Entering Wet Bulb Temperature	Total Air Volume	Outdoor Air Temperature Entering Outdoor Coil																			
		85°F					95°F					105°F					115°F				
		Total Cool Cap.	Comp. Motor Input	Sensible To Total Ratio (S/T)			Total Cool Cap.	Comp. Motor Input	Sensible To Total Ratio (S/T)			Total Cool Cap.	Comp. Motor Input	Sensible To Total Ratio (S/T)			Total Cool Cap.	Comp. Motor Input	Sensible To Total Ratio (S/T)		
				Dry Bulb					Dry Bulb					Dry Bulb					Dry Bulb		
cfm	kBtuh	kW	75°F	80°F	85°F	kBtuh	kW	75°F	80°F	85°F	kBtuh	kW	75°F	80°F	85°F	kBtuh	kW	75°F	80°F	85°F	
63°F	4160	148.1	9.05	0.70	0.85	0.99	136.5	10.20	0.71	0.87	1.00	124.5	11.51	0.72	0.9	1.00	112.1	13.01	0.73	0.93	1.00
	5200	157.1	9.11	0.76	0.94	1.00	145.1	10.26	0.77	0.96	1.00	132.6	11.57	0.79	0.99	1.00	120.5	13.08	0.81	1.00	1.00
	6240	164.5	9.17	0.82	0.99	1.00	152.7	10.32	0.83	1.00	1.00	141.1	11.64	0.86	1.00	1.00	129.1	13.15	0.89	1.00	1.00
67°F	4160	159.3	9.13	0.54	0.68	0.82	147.4	10.28	0.54	0.69	0.84	135.3	11.59	0.53	0.70	0.86	122.4	13.09	0.53	0.71	0.89
	5200	169.0	9.20	0.58	0.74	0.90	156.5	10.35	0.58	0.75	0.92	143.4	11.66	0.58	0.77	0.95	129.8	13.16	0.58	0.79	0.98
	6240	175.9	9.25	0.61	0.80	0.97	162.7	10.40	0.62	0.81	0.99	149.1	11.71	0.62	0.83	1.00	135.2	13.2	0.63	0.86	1.00
71°F	4160	170.4	9.21	0.40	0.53	0.66	158.1	10.36	0.38	0.53	0.66	145.8	11.68	0.37	0.53	0.67	132.6	13.18	0.35	0.52	0.69
	5200	180.5	9.29	0.41	0.57	0.72	167.6	10.44	0.41	0.57	0.73	154.2	11.75	0.39	0.57	0.74	140.5	13.25	0.37	0.58	0.76
	6240	187.9	9.35	0.43	0.61	0.77	174.4	10.50	0.42	0.61	0.79	160.4	11.81	0.41	0.61	0.81	146.2	13.31	0.40	0.62	0.84

15 TON HIGH EFFICIENCY LCH180H4B (PART LOAD) - CONSTANT AIR VOLUME

Entering Wet Bulb Temperature	Total Air Volume	Outdoor Air Temperature Entering Outdoor Coil																			
		65°F					75°F					85°F					95°F				
		Total Cool Cap.	Comp. Motor Input	Sensible To Total Ratio (S/T)			Total Cool Cap.	Comp. Motor Input	Sensible To Total Ratio (S/T)			Total Cool Cap.	Comp. Motor Input	Sensible To Total Ratio (S/T)			Total Cool Cap.	Comp. Motor Input	Sensible To Total Ratio (S/T)		
				Dry Bulb					Dry Bulb					Dry Bulb					Dry Bulb		
cfm	kBtuh	kW	75°F	80°F	85°F	kBtuh	kW	75°F	80°F	85°F	kBtuh	kW	75°F	80°F	85°F	kBtuh	kW	75°F	80°F	85°F	
63°F	4800	127.8	5.04	0.70	0.82	0.93	120.4	5.79	0.7	0.82	0.94	112.8	6.62	0.70	0.83	0.96	104.8	7.53	0.70	0.85	0.98
	6000	136.3	5.05	0.74	0.87	0.99	128.3	5.81	0.75	0.88	1.00	120.1	6.64	0.75	0.90	1.00	111.6	7.56	0.76	0.92	1.00
	7200	142.4	5.05	0.78	0.92	1.00	134.1	5.82	0.79	0.94	1.00	125.4	6.66	0.80	0.96	1.00	116.7	7.58	0.81	0.98	1.00
67°F	4800	136.5	5.05	0.56	0.68	0.79	129.0	5.81	0.55	0.68	0.79	121.1	6.65	0.55	0.68	0.80	112.8	7.56	0.54	0.68	0.81
	6000	145.4	5.06	0.59	0.72	0.84	137.2	5.83	0.58	0.72	0.85	128.8	6.67	0.58	0.73	0.86	120.1	7.60	0.58	0.74	0.88
	7200	151.9	5.06	0.61	0.76	0.89	143.3	5.84	0.61	0.77	0.91	134.5	6.69	0.61	0.78	0.93	125.3	7.62	0.61	0.79	0.95
71°F	4800	145.1	5.06	0.44	0.55	0.65	137.2	5.83	0.42	0.54	0.65	129.2	6.67	0.41	0.54	0.66	120.6	7.60	0.40	0.53	0.66
	6000	154.3	5.07	0.45	0.57	0.70	145.9	5.85	0.43	0.57	0.70	137.2	6.70	0.42	0.57	0.71	128.1	7.63	0.41	0.57	0.71
	7200	161.0	5.08	0.46	0.6	0.74	152.3	5.86	0.44	0.6	0.74	143.1	6.72	0.44	0.6	0.76	133.6	7.66	0.43	0.61	0.77

15 TON HIGH EFFICIENCY LCH180H4B (FULL LOAD) - CONSTANT AIR VOLUME

Entering Wet Bulb Temperature	Total Air Volume	Outdoor Air Temperature Entering Outdoor Coil																			
		85°F					95°F					105°F					115°F				
		Total Cool Cap.	Comp. Motor Input	Sensible To Total Ratio (S/T)			Total Cool Cap.	Comp. Motor Input	Sensible To Total Ratio (S/T)			Total Cool Cap.	Comp. Motor Input	Sensible To Total Ratio (S/T)			Total Cool Cap.	Comp. Motor Input	Sensible To Total Ratio (S/T)		
				Dry Bulb					Dry Bulb					Dry Bulb					Dry Bulb		
cfm	kBtuh	kW	75°F	80°F	85°F	kBtuh	kW	75°F	80°F	85°F	kBtuh	kW	75°F	80°F	85°F	kBtuh	kW	75°F	80°F	85°F	
63°F	4800	172.5	9.96	0.71	0.85	0.99	160.1	11.32	0.71	0.87	1.00	146.8	12.83	0.72	0.90	1.00	132.7	14.51	0.74	0.93	1.00
	6000	182.6	9.99	0.77	0.93	1.00	169.5	11.37	0.78	0.95	1.00	155.7	12.89	0.79	0.98	1.00	141.3	14.57	0.81	1.00	1.00
	7200	190.3	10.02	0.82	0.99	1.00	177.3	11.41	0.83	1.00	1.00	164.3	12.94	0.86	1.00	1.00	150.5	14.64	0.89	1.00	1.00
67°F	4800	185.0	10.00	0.55	0.69	0.82	172.1	11.38	0.55	0.69	0.84	158.6	12.90	0.54	0.70	0.86	144.0	14.59	0.54	0.72	0.89
	6000	195.8	10.04	0.58	0.74	0.90	182.1	11.43	0.58	0.76	0.92	167.5	12.96	0.59	0.77	0.95	152.2	14.65	0.59	0.79	0.98
	7200	203.7	10.07	0.62	0.8	0.97	189.3	11.46	0.62	0.81	0.99	173.9	13.00	0.63	0.84	1.00	157.8	14.69	0.63	0.86	1.00
71°F	4800	197.2	10.04	0.41	0.54	0.67	183.9	11.43	0.39	0.54	0.67	169.9	12.97	0.38	0.53	0.68	155.0	14.67	0.36	0.53	0.69
	6000	208.4	10.09	0.42	0.58	0.72	194.2	11.48	0.41	0.58	0.73	179.4	13.03	0.4	0.58	0.75	163.3	14.73	0.38	0.59	0.77
	7200	216.6	10.12	0.43	0.61	0.78	201.8	11.52	0.42	0.62	0.79	186.2	13.07	0.42	0.62	0.81	169.7	14.78	0.41	0.63	0.84

RATINGS

NOTE – For Temperatures and Capacities not shown in tables, see bulletin – Cooling Unit Rating Table Correction Factor Data in Miscellaneous Engineering Data section.

17.5 TON HIGH EFFICIENCY LCH210H4B (PART LOAD) - CONSTANT AIR VOLUME

Entering Wet Bulb Temperature	Total Air Volume	Outdoor Air Temperature Entering Outdoor Coil																			
		65°F					75°F					85°F					95°F				
		Total Cool Cap.	Comp. Motor Input	Sensible To Total Ratio (S/T)			Total Cool Cap.	Comp. Motor Input	Sensible To Total Ratio (S/T)			Total Cool Cap.	Comp. Motor Input	Sensible To Total Ratio (S/T)			Total Cool Cap.	Comp. Motor Input	Sensible To Total Ratio (S/T)		
				Dry Bulb					Dry Bulb					Dry Bulb					Dry Bulb		
cfm	kBtuh	kW	75°F	80°F	85°F	kBtuh	kW	75°F	80°F	85°F	kBtuh	kW	75°F	80°F	85°F	kBtuh	kW	75°F	80°F	85°F	
63°F	5600	142.9	5.49	0.71	0.85	0.97	134.4	6.23	0.72	0.86	0.99	125.5	7.05	0.72	0.88	1.00	116.4	7.97	0.74	0.9	1.00
	7000	151.1	5.54	0.76	0.92	1.00	142.3	6.29	0.77	0.94	1.00	133	7.11	0.79	0.96	1.00	123.5	8.03	0.80	0.98	1.00
	8400	157.9	5.58	0.82	0.98	1.00	148.7	6.34	0.83	1.00	1.00	139.3	7.16	0.84	1.00	1.00	130.5	8.08	0.87	1.00	1.00
67°F	5600	153.6	5.55	0.56	0.69	0.81	144.5	6.30	0.56	0.69	0.83	135.3	7.13	0.56	0.70	0.84	125.7	8.04	0.56	0.71	0.86
	7000	161.9	5.61	0.60	0.74	0.88	152.1	6.36	0.6	0.75	0.90	142.5	7.19	0.60	0.77	0.92	132.2	8.10	0.61	0.78	0.95
	8400	167.9	5.65	0.63	0.79	0.95	157.9	6.41	0.63	0.81	0.97	147.6	7.23	0.63	0.82	0.99	137.0	8.14	0.63	0.84	1.00
71°F	5600	164.4	5.63	0.43	0.55	0.67	154.9	6.38	0.42	0.55	0.67	145.2	7.21	0.41	0.54	0.68	135.3	8.13	0.4	0.55	0.69
	7000	172.9	5.69	0.45	0.59	0.72	162.9	6.45	0.44	0.59	0.73	152.6	7.27	0.43	0.59	0.74	142.1	8.19	0.42	0.60	0.76
	8400	179.1	5.74	0.45	0.62	0.77	168.6	6.49	0.46	0.63	0.79	157.8	7.32	0.45	0.63	0.8	146.5	8.24	0.44	0.64	0.82

17.5 TON HIGH EFFICIENCY LCH210H4B (FULL LOAD) - CONSTANT AIR VOLUME

Entering Wet Bulb Temperature	Total Air Volume	Outdoor Air Temperature Entering Outdoor Coil																			
		85°F					95°F					105°F					115°F				
		Total Cool Cap.	Comp. Motor Input	Sensible To Total Ratio (S/T)			Total Cool Cap.	Comp. Motor Input	Sensible To Total Ratio (S/T)			Total Cool Cap.	Comp. Motor Input	Sensible To Total Ratio (S/T)			Total Cool Cap.	Comp. Motor Input	Sensible To Total Ratio (S/T)		
				Dry Bulb					Dry Bulb					Dry Bulb					Dry Bulb		
cfm	kBtuh	kW	75°F	80°F	85°F	kBtuh	kW	75°F	80°F	85°F	kBtuh	kW	75°F	80°F	85°F	kBtuh	kW	75°F	80°F	85°F	
63°F	5600	197.5	11.26	0.71	0.86	0.99	183.2	12.71	0.73	0.89	1.00	168.8	14.37	0.74	0.91	1.00	153.6	16.25	0.75	0.94	1.00
	7000	209.3	11.34	0.78	0.95	1.00	194.5	12.8	0.79	0.97	1.00	179.6	14.45	0.81	0.99	1.00	164.6	16.33	0.83	1.00	1.00
	8400	219.3	11.42	0.83	0.99	1.00	205.2	12.89	0.85	1.00	1.00	190.5	14.55	0.88	1.00	1.00	175.2	16.42	0.91	1.00	1.00
67°F	5600	212.6	11.36	0.55	0.69	0.83	198.1	12.83	0.55	0.70	0.85	182.6	14.48	0.55	0.71	0.87	166.4	16.34	0.55	0.73	0.90
	7000	224.4	11.46	0.59	0.76	0.91	208.9	12.92	0.60	0.77	0.94	192.3	14.56	0.60	0.79	0.96	175.2	16.41	0.60	0.81	0.98
	8400	232.7	11.52	0.62	0.81	0.98	216.2	12.98	0.63	0.83	0.99	199.3	14.62	0.64	0.85	1.00	181.7	16.47	0.64	0.88	1.00
71°F	5600	228.4	11.49	0.41	0.54	0.67	212.9	12.95	0.40	0.54	0.68	197.0	14.60	0.39	0.55	0.69	180.1	16.46	0.38	0.55	0.71
	7000	240.3	11.59	0.42	0.59	0.73	223.9	13.05	0.42	0.59	0.75	206.9	14.69	0.41	0.59	0.76	189.0	16.54	0.40	0.60	0.78
	8400	248.5	11.66	0.44	0.62	0.79	231.5	13.12	0.44	0.63	0.81	214.0	14.75	0.43	0.64	0.83	195.1	16.60	0.42	0.64	0.86

20 TON HIGH EFFICIENCY LCH240H4B (PART LOAD) - CONSTANT AIR VOLUME

Entering Wet Bulb Temperature	Total Air Volume	Outdoor Air Temperature Entering Outdoor Coil																			
		65°F					75°F					85°F					95°F				
		Total Cool Cap.	Comp. Motor Input	Sensible To Total Ratio (S/T)			Total Cool Cap.	Comp. Motor Input	Sensible To Total Ratio (S/T)			Total Cool Cap.	Comp. Motor Input	Sensible To Total Ratio (S/T)			Total Cool Cap.	Comp. Motor Input	Sensible To Total Ratio (S/T)		
				Dry Bulb					Dry Bulb					Dry Bulb					Dry Bulb		
cfm	kBtuh	kW	75°F	80°F	85°F	kBtuh	kW	75°F	80°F	85°F	kBtuh	kW	75°F	80°F	85°F	kBtuh	kW	75°F	80°F	85°F	
63°F	6400	130.1	5.15	0.69	0.81	0.94	123.5	5.86	0.69	0.83	0.96	116.6	6.64	0.70	0.84	0.98	109.3	7.52	0.71	0.86	0.99
	8000	137.5	5.20	0.73	0.88	0.99	130.5	5.91	0.74	0.90	1.00	123.1	6.69	0.75	0.92	1.00	115.6	7.57	0.77	0.94	1.00
	9600	143.4	5.25	0.78	0.94	1.00	136.1	5.96	0.79	0.96	1.00	128.4	6.74	0.81	0.98	1.00	120.6	7.62	0.83	0.99	1.00
67°F	6400	139.2	5.22	0.55	0.66	0.78	132.2	5.93	0.55	0.67	0.79	124.7	6.71	0.55	0.68	0.81	117.0	7.58	0.55	0.69	0.83
	8000	146.6	5.27	0.57	0.71	0.85	139.1	5.99	0.58	0.72	0.86	131.3	6.77	0.58	0.73	0.88	123.0	7.64	0.58	0.75	0.91
	9600	152.1	5.31	0.60	0.76	0.91	144.2	6.03	0.61	0.77	0.93	135.9	6.81	0.62	0.79	0.96	127.2	7.68	0.62	0.81	0.98
71°F	6400	148.1	5.28	0.42	0.53	0.64	140.8	6.00	0.42	0.53	0.65	133.2	6.79	0.41	0.54	0.65	125.1	7.66	0.41	0.53	0.66
	8000	155.9	5.34	0.43	0.56	0.69	148.1	6.06	0.43	0.56	0.69	139.8	6.85	0.42	0.57	0.71	131.2	7.73	0.42	0.58	0.73
	9600	161.6	5.39	0.44	0.59	0.73	153.2	6.11	0.44	0.60	0.75	144.7	6.90	0.44	0.61	0.76	135.7	7.77	0.44	0.62	0.78

20 TON HIGH EFFICIENCY LCH240H4B (FULL LOAD) - CONSTANT AIR VOLUME

Entering Wet Bulb Temperature	Total Air Volume	Outdoor Air Temperature Entering Outdoor Coil																			
		85°F					95°F					105°F					115°F				
		Total Cool Cap.	Comp. Motor Input	Sensible To Total Ratio (S/T)			Total Cool Cap.	Comp. Motor Input	Sensible To Total Ratio (S/T)			Total Cool Cap.	Comp. Motor Input	Sensible To Total Ratio (S/T)			Total Cool Cap.	Comp. Motor Input	Sensible To Total Ratio (S/T)		
				Dry Bulb					Dry Bulb					Dry Bulb					Dry Bulb		
cfm	kBtuh	kW	75°F	80°F	85°F	kBtuh	kW	75°F	80°F	85°F	kBtuh	kW	75°F	80°F	85°F	kBtuh	kW	75°F	80°F	85°F	
63°F	6400	236.6	13.31	0.73	0.88	1.00	221.6	15.06	0.74	0.91	1.00	205.8	17.06	0.76	0.94	1.00	189.2	19.35	0.78	0.97	1.00
	8000	249.2	13.43	0.79	0.97	1.00	233.7	15.17	0.80	0.98	1.00	217.5	17.17	0.83	0.99	1.00	201.1	19.47	0.86	1.00	1.00
	9600	260.1	13.53	0.85	1.00	1.00	244.7	15.28	0.87	1.00	1.00	228.9	17.29	0.90	1.00	1.00	212.1	19.59	0.94	1.00	1.00
67°F	6400	252.7	13.46	0.56	0.71	0.85	236.8	15.20	0.57	0.72	0.87	220.0	17.20	0.57	0.73	0.90	202.2	19.48	0.58	0.76	0.93
	8000	264.4	13.57	0.60	0.77	0.93	247.3	15.31	0.61	0.78	0.96	229.6	17.30	0.62	0.81	0.98	210.9	19.57	0.63	0.84	0.99
	9600	272.8	13.66	0.64	0.83	0.99	255.3	15.39	0.64	0.85	1.00	236.8	17.38	0.65	0.88	1.00	217.9	19.65	0.67	0.92	1.00
71°F	6400	269.2	13.62	0.41	0.55	0.68	252.6	15.37	0.41	0.56	0.70	235.2	17.36	0.41	0.56	0.71	216.6	19.64	0.40	0.57	0.73
	8000	281.5	13.75	0.43	0.59	0.74	263.7	15.49	0.43	0.60	0.76	245.0	17.48	0.43	0.61	0.78	225.2	19.74	0.42	0.62	0.81
	9600	289.9	13.83	0.45	0.63	0.81	271.3	15.57	0.45	0.64	0.83	252.0	17.55	0.45	0.65	0.86	231.3	19.81	0.44	0.67	0.89

RATINGS

NOTE – For Temperatures and Capacities not shown in tables, see bulletin – Cooling Unit Rating Table Correction Factor Data in Miscellaneous Engineering Data section.

25 TON STANDARD EFFICIENCY LCH300S4B (PART LOAD) - CONSTANT AIR VOLUME

Entering Wet Bulb Temperature	Total Air Volume	Outdoor Air Temperature Entering Outdoor Coil																			
		65°F					75°F					85°F					95°F				
		Total Cool Cap.	Comp. Motor Input	Sensible To Total Ratio (S/T) Dry Bulb			Total Cool Cap.	Comp. Motor Input	Sensible To Total Ratio (S/T) Dry Bulb			Total Cool Cap.	Comp. Motor Input	Sensible To Total Ratio (S/T) Dry Bulb			Total Cool Cap.	Comp. Motor Input	Sensible To Total Ratio (S/T) Dry Bulb		
				75°F	80°F	85°F			75°F	80°F	85°F			75°F	80°F	85°F			75°F	80°F	85°F
		cfm	kBtuh	kW	75°F	80°F	85°F	kBtuh	kW	75°F	80°F	85°F	kBtuh	kW	75°F	80°F	85°F	kBtuh	kW	75°F	80°F
63°F	8000	147.3	6.36	0.70	0.82	0.95	140.6	7.18	0.71	0.84	0.97	134.8	8.10	0.72	0.86	0.99	129.1	9.16	0.73	0.88	1.00
	9500	152.7	6.41	0.73	0.87	0.99	145.9	7.24	0.74	0.90	1.00	140.0	8.16	0.75	0.92	1.00	133.8	9.22	0.77	0.94	1.00
	11000	157.6	6.47	0.75	0.92	1.00	150.5	7.29	0.78	0.95	1.00	144.1	8.22	0.80	0.97	1.00	137.6	9.27	0.82	0.98	1.00
67°F	8000	156.1	6.45	0.55	0.67	0.79	149.2	7.27	0.56	0.68	0.81	142.8	8.20	0.57	0.70	0.83	136.3	9.25	0.57	0.70	0.84
	9500	161.6	6.51	0.57	0.70	0.84	154.0	7.33	0.58	0.71	0.86	147.3	8.26	0.59	0.73	0.88	140.8	9.31	0.60	0.75	0.91
	11000	165.6	6.55	0.59	0.73	0.89	158.2	7.38	0.60	0.76	0.92	151.1	8.31	0.61	0.77	0.94	144.2	9.37	0.63	0.79	0.96
71°F	8000	165.2	6.55	0.42	0.54	0.65	157.7	7.38	0.42	0.54	0.66	151.1	8.31	0.42	0.55	0.67	144.2	9.37	0.43	0.56	0.69
	9500	170.7	6.61	0.43	0.56	0.68	162.8	7.44	0.43	0.57	0.70	155.4	8.37	0.44	0.57	0.71	148.2	9.42	0.44	0.58	0.72
	11000	174.8	6.66	0.44	0.58	0.71	166.6	7.49	0.45	0.59	0.73	159.1	8.42	0.44	0.60	0.75	151.8	9.47	0.45	0.61	0.77

25 TON STANDARD EFFICIENCY LCH300S4B (FULL LOAD) - CONSTANT AIR VOLUME

Entering Wet Bulb Temperature	Total Air Volume	Outdoor Air Temperature Entering Outdoor Coil																			
		85°F					95°F					105°F					115°F				
		Total Cool Cap.	Comp. Motor Input	Sensible To Total Ratio (S/T) Dry Bulb			Total Cool Cap.	Comp. Motor Input	Sensible To Total Ratio (S/T) Dry Bulb			Total Cool Cap.	Comp. Motor Input	Sensible To Total Ratio (S/T) Dry Bulb			Total Cool Cap.	Comp. Motor Input	Sensible To Total Ratio (S/T) Dry Bulb		
				75°F	80°F	85°F			75°F	80°F	85°F			75°F	80°F	85°F			75°F	80°F	85°F
		cfm	kBtuh	kW	75°F	80°F	85°F	kBtuh	kW	75°F	80°F	85°F	kBtuh	kW	75°F	80°F	85°F	kBtuh	kW	75°F	80°F
63°F	8000	277.2	17.80	0.72	0.87	1.00	264.6	19.95	0.74	0.89	1.00	251.7	22.43	0.75	0.92	1.00	238.5	25.35	0.78	0.95	1.00
	9500	287.2	17.97	0.76	0.93	1.00	273.8	20.12	0.78	0.96	1.00	260.1	22.59	0.80	0.98	1.00	246.0	25.49	0.83	1.00	1.00
	11000	295.0	18.11	0.80	0.98	1.00	280.6	20.25	0.83	1.00	1.00	267.4	22.73	0.85	1.00	1.00	254.5	25.68	0.88	1.00	1.00
67°F	8000	293.2	18.08	0.57	0.70	0.83	279.6	20.23	0.58	0.71	0.86	265.8	22.71	0.59	0.73	0.88	251.7	25.63	0.60	0.75	0.91
	9500	302.9	18.25	0.59	0.74	0.89	288.4	20.39	0.60	0.76	0.92	273.9	22.86	0.62	0.78	0.95	258.8	25.78	0.63	0.80	0.98
	11000	310.1	18.38	0.62	0.78	0.95	295.3	20.52	0.63	0.80	0.98	279.9	22.99	0.64	0.83	1.00	264.5	25.89	0.65	0.85	1.00
71°F	8000	310.0	18.38	0.43	0.56	0.68	295.5	20.53	0.43	0.57	0.69	280.6	23.00	0.43	0.58	0.71	265.8	25.92	0.44	0.59	0.73
	9500	319.0	18.54	0.44	0.58	0.72	304.0	20.68	0.44	0.59	0.74	288.9	23.17	0.45	0.61	0.75	273.0	26.07	0.45	0.62	0.78
	11000	326.9	18.68	0.44	0.61	0.76	311.2	20.82	0.45	0.62	0.78	294.9	23.29	0.46	0.63	0.80	278.5	26.19	0.47	0.65	0.83

RATINGS

NOTE – For Temperatures and Capacities not shown in tables, see bulletin – Cooling Unit Rating Table Correction Factor Data in Miscellaneous Engineering Data section.

13 TON HIGH EFFICIENCY LCH156H4V (1 COMPRESSOR OPERATING) - VARIABLE AIR VOLUME

Entering Wet Bulb Temperature	Total Air Volume	Outdoor Air Temperature Entering Outdoor Coil																							
		65°F						75°F						85°F						95°F					
		Total Cool Cap.	Comp. Motor Input	Sensible To Total Ratio (S/T)			Total Cool Cap.	Comp. Motor Input	Sensible To Total Ratio (S/T)			Total Cool Cap.	Comp. Motor Input	Sensible To Total Ratio (S/T)			Total Cool Cap.	Comp. Motor Input	Sensible To Total Ratio (S/T)						
				Dry Bulb					Dry Bulb					Dry Bulb					Dry Bulb						
cfm	kBtuh	kW	75°F	80°F	85°F	kBtuh	kW	75°F	80°F	85°F	kBtuh	kW	75°F	80°F	85°F	kBtuh	kW	75°F	80°F	85°F					
63°F	1500	51.8	2.25	0.74	0.87	0.96	49.5	2.58	0.74	0.88	0.96	46.9	2.93	0.75	0.89	0.97	44.3	3.33	0.76	0.9	0.98				
	1800	54.2	2.25	0.77	0.9	0.98	51.7	2.59	0.78	0.91	0.99	49.1	2.95	0.79	0.92	1	46.3	3.34	0.79	0.93	1				
	2100	56.1	2.26	0.8	0.93	1	53.5	2.6	0.8	0.94	1	50.8	2.96	0.81	0.95	1	47.9	3.35	0.83	0.96	1				
67°F	1500	54.3	2.25	0.49	0.69	0.83	51.9	2.59	0.49	0.69	0.84	49.4	2.95	0.48	0.7	0.85	46.6	3.34	0.48	0.71	0.87				
	1800	56.8	2.26	0.51	0.73	0.87	54.2	2.6	0.51	0.73	0.88	51.4	2.96	0.5	0.75	0.89	48.5	3.35	0.51	0.76	0.9				
	2100	58.7	2.27	0.53	0.76	0.9	56	2.61	0.53	0.77	0.91	53.2	2.97	0.53	0.78	0.92	50.2	3.36	0.53	0.79	0.94				
71°F	1500	57.1	2.26	0.25	0.45	0.64	54.5	2.6	0.24	0.45	0.64	51.9	2.96	0.22	0.44	0.65	49	3.36	0.21	0.44	0.66				
	1800	59.5	2.27	0.24	0.47	0.68	56.9	2.61	0.23	0.47	0.68	54	2.97	0.22	0.47	0.69	51.1	3.37	0.21	0.47	0.72				
	2100	61.4	2.28	0.24	0.49	0.71	58.7	2.62	0.23	0.49	0.73	55.7	2.98	0.22	0.5	0.74	52.6	3.38	0.21	0.5	0.76				

13 TON HIGH EFFICIENCY LCH156H4V (2 COMPRESSORS OPERATING) - VARIABLE AIR VOLUME

Entering Wet Bulb Temperature	Total Air Volume	Outdoor Air Temperature Entering Outdoor Coil																							
		65°F						75°F						85°F						95°F					
		Total Cool Cap.	Comp. Motor Input	Sensible To Total Ratio (S/T)			Total Cool Cap.	Comp. Motor Input	Sensible To Total Ratio (S/T)			Total Cool Cap.	Comp. Motor Input	Sensible To Total Ratio (S/T)			Total Cool Cap.	Comp. Motor Input	Sensible To Total Ratio (S/T)						
				Dry Bulb					Dry Bulb					Dry Bulb					Dry Bulb						
cfm	kBtuh	kW	75°F	80°F	85°F	kBtuh	kW	75°F	80°F	85°F	kBtuh	kW	75°F	80°F	85°F	kBtuh	kW	75°F	80°F	85°F					
63°F	3000	108.4	4.56	0.72	0.85	0.96	103.3	5.23	0.72	0.86	0.98	97.8	5.95	0.73	0.88	0.99	91.9	6.75	0.74	0.89	0.99				
	3500	112.5	4.58	0.75	0.89	0.99	107	5.25	0.75	0.9	1	101	5.97	0.76	0.92	1	95.2	6.77	0.78	0.94	1				
	4000	115.7	4.6	0.77	0.93	1	110.2	5.26	0.79	0.94	1	104.5	5.99	0.8	0.96	1	98.5	6.79	0.81	0.98	1				
67°F	3000	114.4	4.59	0.57	0.7	0.82	109.1	5.26	0.57	0.7	0.83	103.6	5.98	0.58	0.71	0.84	97.6	6.78	0.58	0.72	0.86				
	3500	119	4.61	0.59	0.73	0.86	113.4	5.28	0.59	0.74	0.87	107.5	6.01	0.6	0.75	0.89	101.2	6.81	0.6	0.76	0.91				
	4000	122.6	4.63	0.61	0.75	0.9	116.8	5.3	0.61	0.76	0.92	110.6	6.03	0.62	0.78	0.93	104	6.83	0.62	0.8	0.95				
71°F	3000	120	4.61	0.44	0.56	0.68	114.6	5.29	0.43	0.56	0.68	108.9	6.01	0.43	0.56	0.69	102.7	6.82	0.42	0.57	0.7				
	3500	125	4.64	0.44	0.58	0.7	119.1	5.31	0.44	0.58	0.71	113	6.04	0.44	0.58	0.72	106.7	6.85	0.44	0.59	0.74				
	4000	128.8	4.65	0.45	0.59	0.73	122.8	5.33	0.45	0.6	0.74	116.4	6.06	0.45	0.61	0.76	109.7	6.86	0.45	0.62	0.77				

13 TON HIGH EFFICIENCY LCH156H4V (3 COMPRESSORS OPERATING) - VARIABLE AIR VOLUME

Entering Wet Bulb Temperature	Total Air Volume	Outdoor Air Temperature Entering Outdoor Coil																							
		85°F						95°F						105°F						115°F					
		Total Cool Cap.	Comp. Motor Input	Sensible To Total Ratio (S/T)			Total Cool Cap.	Comp. Motor Input	Sensible To Total Ratio (S/T)			Total Cool Cap.	Comp. Motor Input	Sensible To Total Ratio (S/T)			Total Cool Cap.	Comp. Motor Input	Sensible To Total Ratio (S/T)						
				Dry Bulb					Dry Bulb					Dry Bulb					Dry Bulb						
cfm	kBtuh	kW	75°F	80°F	85°F	kBtuh	kW	75°F	80°F	85°F	kBtuh	kW	75°F	80°F	85°F	kBtuh	kW	75°F	80°F	85°F					
63°F	4160	151.8	9.02	0.72	0.84	0.95	143.1	10.22	0.72	0.85	0.97	133.7	11.57	0.74	0.87	0.99	123.6	13.1	0.75	0.89	1				
	5200	159.9	9.07	0.77	0.9	1	150.4	10.28	0.78	0.92	1	140.4	11.62	0.79	0.94	1	130.1	13.15	0.81	0.97	1				
	6240	166	9.1	0.81	0.96	1	156.6	10.32	0.83	0.98	1	146.6	11.67	0.84	0.99	1	136.2	13.2	0.87	1	1				
67°F	4160	158.6	9.05	0.56	0.7	0.81	149.2	10.26	0.56	0.71	0.82	139.5	11.61	0.57	0.71	0.84	129.3	13.15	0.58	0.73	0.86				
	5200	166.6	9.1	0.59	0.74	0.87	157.1	10.32	0.59	0.75	0.89	146.9	11.67	0.62	0.77	0.91	135.9	13.2	0.63	0.79	0.94				
	6240	172.9	9.14	0.62	0.79	0.93	162.9	10.36	0.64	0.8	0.95	152.2	11.71	0.64	0.82	0.98	140.6	13.24	0.66	0.84	0.99				
71°F	4160	167.9	9.11	0.42	0.55	0.68	158.5	10.33	0.42	0.56	0.68	147.9	11.68	0.41	0.55	0.7	136.8	13.2	0.41	0.56	0.71				
	5200	175.8	9.16	0.44	0.59	0.72	165.6	10.37	0.44	0.59	0.74	154.7	11.73	0.43	0.6	0.76	142.8	13.25	0.43	0.61	0.77				
	6240	181.9	9.2	0.46	0.62	0.77	170.8	10.41	0.46	0.63	0.79	159.5	11.77	0.45	0.64	0.81	147.1	13.29	0.45	0.65	0.83				

RATINGS

NOTE – For Temperatures and Capacities not shown in tables, see bulletin – Cooling Unit Rating Table Correction Factor Data in Miscellaneous Engineering Data section.

15 TON HIGH EFFICIENCY LCH180H4V (1 COMPRESSOR OPERATING) - VARIABLE AIR VOLUME

Entering Wet Bulb Temperature	Total Air Volume	Outdoor Air Temperature Entering Outdoor Coil																			
		65°F					75°F					85°F					95°F				
		Total Cool Cap.	Comp. Motor Input	Sensible To Total Ratio (S/T)			Total Cool Cap.	Comp. Motor Input	Sensible To Total Ratio (S/T)			Total Cool Cap.	Comp. Motor Input	Sensible To Total Ratio (S/T)			Total Cool Cap.	Comp. Motor Input	Sensible To Total Ratio (S/T)		
				Dry Bulb					Dry Bulb					Dry Bulb					Dry Bulb		
cfm	kBtuh	kW	75°F	80°F	85°F	kBtuh	kW	75°F	80°F	85°F	kBtuh	kW	75°F	80°F	85°F	kBtuh	kW	75°F	80°F	85°F	
63°F	1600	58.6	2.51	0.58	0.73	0.87	55.8	2.87	0.59	0.74	0.89	52.7	3.25	0.59	0.75	0.9	49.5	3.67	0.59	0.77	0.93
	2000	62.3	2.53	0.62	0.78	0.93	59.2	2.89	0.62	0.79	0.95	55.9	3.27	0.63	0.81	0.97	52.4	3.68	0.64	0.83	0.99
	2400	65	2.55	0.64	0.83	0.98	61.7	2.9	0.65	0.85	0.99	58.3	3.28	0.67	0.87	1	54.7	3.7	0.68	0.89	1
67°F	1600	61.7	2.53	0.39	0.54	0.68	58.7	2.88	0.39	0.55	0.69	55.6	3.26	0.38	0.55	0.7	52.2	3.68	0.37	0.55	0.72
	2000	65.3	2.55	0.4	0.58	0.73	62.1	2.91	0.4	0.58	0.75	58.8	3.28	0.4	0.59	0.77	55.2	3.7	0.39	0.6	0.78
	2400	68.1	2.57	0.42	0.61	0.78	64.7	2.92	0.42	0.62	0.8	61.2	3.3	0.42	0.63	0.82	57.4	3.71	0.42	0.64	0.84
71°F	1600	64.9	2.55	0.2	0.36	0.5	61.8	2.9	0.19	0.35	0.5	58.6	3.28	0.18	0.35	0.51	55.2	3.7	0.16	0.34	0.51
	2000	68.5	2.57	0.2	0.37	0.53	65.3	2.92	0.18	0.37	0.54	61.9	3.3	0.17	0.37	0.54	58.2	3.71	0.16	0.36	0.56
	2400	71.3	2.59	0.19	0.39	0.57	67.9	2.94	0.19	0.39	0.58	64.3	3.32	0.17	0.39	0.59	60.5	3.73	0.16	0.39	0.61

15 TON HIGH EFFICIENCY LCH180H4V (2 COMPRESSORS OPERATING) - VARIABLE AIR VOLUME

Entering Wet Bulb Temperature	Total Air Volume	Outdoor Air Temperature Entering Outdoor Coil																			
		65°F					75°F					85°F					95°F				
		Total Cool Cap.	Comp. Motor Input	Sensible To Total Ratio (S/T)			Total Cool Cap.	Comp. Motor Input	Sensible To Total Ratio (S/T)			Total Cool Cap.	Comp. Motor Input	Sensible To Total Ratio (S/T)			Total Cool Cap.	Comp. Motor Input	Sensible To Total Ratio (S/T)		
				Dry Bulb					Dry Bulb					Dry Bulb					Dry Bulb		
cfm	kBtuh	kW	75°F	80°F	85°F	kBtuh	kW	75°F	80°F	85°F	kBtuh	kW	75°F	80°F	85°F	kBtuh	kW	75°F	80°F	85°F	
63°F	3200	124.3	5.08	0.7	0.82	0.94	117.9	5.79	0.71	0.83	0.95	111.2	6.55	0.71	0.85	0.97	104.2	7.38	0.72	0.86	0.98
	4000	131.8	5.13	0.74	0.87	0.99	125	5.83	0.75	0.89	0.99	117.8	6.59	0.76	0.91	1	110.2	7.42	0.77	0.93	1
	4800	137.2	5.16	0.78	0.93	1	130.1	5.86	0.79	0.94	1	122.9	6.62	0.8	0.96	1	115.5	7.45	0.81	0.98	1
67°F	3200	131.5	5.13	0.56	0.68	0.79	124.9	5.83	0.56	0.68	0.8	118.2	6.59	0.56	0.69	0.81	111.1	7.42	0.56	0.7	0.83
	4000	139.8	5.18	0.58	0.72	0.84	132.7	5.88	0.59	0.73	0.86	125.3	6.63	0.59	0.74	0.88	117.7	7.47	0.59	0.75	0.9
	4800	145.6	5.22	0.61	0.76	0.9	138.3	5.92	0.61	0.77	0.91	130.6	6.67	0.62	0.78	0.93	122.5	7.5	0.62	0.8	0.96
71°F	3200	138	5.16	0.43	0.55	0.66	131.5	5.87	0.43	0.55	0.66	124.5	6.63	0.42	0.55	0.67	117.2	7.46	0.42	0.55	0.68
	4000	146.8	5.22	0.44	0.57	0.69	139.7	5.93	0.43	0.58	0.71	132.2	6.68	0.44	0.58	0.72	124.3	7.51	0.43	0.58	0.73
	4800	153.2	5.27	0.45	0.6	0.73	145.7	5.97	0.45	0.6	0.75	137.9	6.72	0.44	0.61	0.76	129.7	7.55	0.44	0.61	0.77

15 TON HIGH EFFICIENCY LCH180H4V (3 COMPRESSORS OPERATING) - VARIABLE AIR VOLUME

Entering Wet Bulb Temperature	Total Air Volume	Outdoor Air Temperature Entering Outdoor Coil																			
		85°F					95°F					105°F					115°F				
		Total Cool Cap.	Comp. Motor Input	Sensible To Total Ratio (S/T)			Total Cool Cap.	Comp. Motor Input	Sensible To Total Ratio (S/T)			Total Cool Cap.	Comp. Motor Input	Sensible To Total Ratio (S/T)			Total Cool Cap.	Comp. Motor Input	Sensible To Total Ratio (S/T)		
				Dry Bulb					Dry Bulb					Dry Bulb					Dry Bulb		
cfm	kBtuh	kW	75°F	80°F	85°F	kBtuh	kW	75°F	80°F	85°F	kBtuh	kW	75°F	80°F	85°F	kBtuh	kW	75°F	80°F	85°F	
63°F	4800	176.3	9.9	0.72	0.83	0.95	165.8	11.16	0.72	0.85	0.96	154.7	12.56	0.73	0.86	0.98	142.9	14.15	0.74	0.88	0.99
	6000	186.7	9.96	0.76	0.89	0.99	175.2	11.21	0.77	0.91	1	163.4	12.62	0.79	0.93	1	151.1	14.22	0.8	0.96	1
	7200	193.9	10.01	0.8	0.95	1	182.5	11.26	0.82	0.97	1	170.8	12.67	0.83	0.99	1	158.6	14.27	0.86	1	1
67°F	4800	185.5	9.96	0.55	0.69	0.8	174.1	11.2	0.55	0.7	0.82	162.3	12.61	0.57	0.71	0.83	150	14.21	0.57	0.73	0.85
	6000	195.1	10.01	0.59	0.74	0.86	183.2	11.26	0.6	0.74	0.88	171.2	12.67	0.59	0.76	0.9	158.6	14.26	0.61	0.78	0.93
	7200	202.7	10.06	0.62	0.78	0.92	190.7	11.32	0.62	0.79	0.94	178.1	12.72	0.64	0.81	0.96	164.7	14.3	0.64	0.83	0.99
71°F	4800	197	10.03	0.42	0.55	0.67	185.4	11.28	0.42	0.54	0.67	173.3	12.68	0.42	0.54	0.69	160.4	14.27	0.41	0.55	0.7
	6000	207.2	10.09	0.43	0.57	0.71	194.6	11.34	0.44	0.59	0.73	181.8	12.74	0.43	0.6	0.74	168.5	14.34	0.43	0.6	0.76
	7200	214.6	10.14	0.45	0.6	0.76	201.4	11.39	0.46	0.62	0.78	188.3	12.79	0.45	0.62	0.79	174.1	14.38	0.44	0.64	0.81

RATINGS

NOTE – For Temperatures and Capacities not shown in tables, see bulletin – Cooling Unit Rating Table Correction Factor Data in Miscellaneous Engineering Data section.

20 TON HIGH EFFICIENCY LCH240H4V (1 COMPRESSOR OPERATING) - VARIABLE AIR VOLUME

Entering Wet Bulb Temperature	Total Air Volume	Outdoor Air Temperature Entering Outdoor Coil																			
		65°F					75°F					85°F					95°F				
		Total Cool Cap.	Comp. Motor Input	Sensible To Total Ratio (S/T)			Total Cool Cap.	Comp. Motor Input	Sensible To Total Ratio (S/T)			Total Cool Cap.	Comp. Motor Input	Sensible To Total Ratio (S/T)			Total Cool Cap.	Comp. Motor Input	Sensible To Total Ratio (S/T)		
				Dry Bulb					Dry Bulb					Dry Bulb					Dry Bulb		
cfm	kBtuh	kW	75°F	80°F	85°F	kBtuh	kW	75°F	80°F	85°F	kBtuh	kW	75°F	80°F	85°F	kBtuh	kW	75°F	80°F	85°F	
63°F	1600	58.5	2.59	0.59	0.74	0.87	56	2.96	0.6	0.75	0.89	53.3	3.36	0.6	0.76	0.91	50.4	3.79	0.61	0.78	0.93
	2000	62	2.59	0.62	0.79	0.93	59.3	2.97	0.63	0.8	0.95	56.5	3.36	0.64	0.82	0.96	53.4	3.79	0.65	0.84	0.98
	2400	64.6	2.6	0.66	0.83	0.97	61.9	2.98	0.66	0.85	0.99	58.9	3.37	0.68	0.87	1	55.7	3.81	0.69	0.89	1
67°F	1600	61.3	2.59	0.4	0.55	0.69	58.7	2.96	0.39	0.55	0.7	56	3.36	0.39	0.56	0.71	53.1	3.8	0.39	0.57	0.73
	2000	64.8	2.61	0.41	0.58	0.74	62.1	2.97	0.41	0.59	0.75	59.2	3.37	0.41	0.6	0.77	56.1	3.81	0.41	0.61	0.79
	2400	67.6	2.62	0.43	0.62	0.78	64.7	2.98	0.43	0.62	0.8	61.6	3.38	0.43	0.64	0.82	58.3	3.81	0.43	0.65	0.84
71°F	1600	64.3	2.6	0.21	0.36	0.51	61.6	2.97	0.2	0.36	0.51	58.8	3.36	0.19	0.36	0.52	55.9	3.8	0.18	0.36	0.52
	2000	67.9	2.61	0.2	0.37	0.54	65.1	2.98	0.19	0.38	0.55	62.1	3.38	0.18	0.38	0.56	58.9	3.81	0.18	0.38	0.57
	2400	70.7	2.63	0.2	0.39	0.57	67.7	2.99	0.19	0.4	0.58	64.5	3.39	0.19	0.4	0.6	61.2	3.82	0.18	0.4	0.62

20 TON HIGH EFFICIENCY LCH240H4V (2 COMPRESSORS OPERATING) - VARIABLE AIR VOLUME

Entering Wet Bulb Temperature	Total Air Volume	Outdoor Air Temperature Entering Outdoor Coil																			
		65°F					75°F					85°F					95°F				
		Total Cool Cap.	Comp. Motor Input	Sensible To Total Ratio (S/T)			Total Cool Cap.	Comp. Motor Input	Sensible To Total Ratio (S/T)			Total Cool Cap.	Comp. Motor Input	Sensible To Total Ratio (S/T)			Total Cool Cap.	Comp. Motor Input	Sensible To Total Ratio (S/T)		
				Dry Bulb					Dry Bulb					Dry Bulb					Dry Bulb		
cfm	kBtuh	kW	75°F	80°F	85°F	kBtuh	kW	75°F	80°F	85°F	kBtuh	kW	75°F	80°F	85°F	kBtuh	kW	75°F	80°F	85°F	
63°F	3200	123.6	5.16	0.71	0.82	0.94	118	5.89	0.71	0.83	0.95	112.2	6.68	0.72	0.85	0.97	105.9	7.54	0.73	0.86	0.98
	4000	130.9	5.19	0.74	0.88	0.99	124.9	5.92	0.75	0.89	0.99	118.5	6.7	0.76	0.91	1	111.8	7.56	0.77	0.93	1
	4800	136.2	5.21	0.78	0.93	1	129.9	5.94	0.79	0.94	1	123.5	6.72	0.8	0.96	1	116.9	7.58	0.82	0.98	1
67°F	3200	130.5	5.19	0.57	0.68	0.79	124.8	5.92	0.57	0.69	0.8	118.9	6.71	0.57	0.7	0.81	112.4	7.56	0.57	0.71	0.83
	4000	138.5	5.22	0.58	0.72	0.84	132.3	5.95	0.59	0.73	0.86	125.9	6.73	0.6	0.74	0.87	119	7.59	0.6	0.75	0.9
	4800	144.3	5.25	0.61	0.75	0.9	137.9	5.98	0.61	0.77	0.91	130.9	6.75	0.62	0.78	0.93	123.8	7.61	0.63	0.8	0.95
71°F	3200	136.8	5.22	0.44	0.55	0.66	131	5.95	0.43	0.55	0.67	124.9	6.73	0.43	0.55	0.68	118.4	7.59	0.42	0.56	0.68
	4000	145.2	5.26	0.44	0.57	0.7	139	5.98	0.44	0.58	0.71	132.4	6.76	0.44	0.59	0.72	125.5	7.62	0.44	0.59	0.73
	4800	151.6	5.29	0.45	0.59	0.73	145	6.01	0.45	0.6	0.74	137.9	6.78	0.44	0.61	0.76	130.6	7.64	0.45	0.62	0.78

20 TON HIGH EFFICIENCY LCH240H4V (3 COMPRESSORS OPERATING) - VARIABLE AIR VOLUME

Entering Wet Bulb Temperature	Total Air Volume	Outdoor Air Temperature Entering Outdoor Coil																			
		65°F					75°F					85°F					95°F				
		Total Cool Cap.	Comp. Motor Input	Sensible To Total Ratio (S/T)			Total Cool Cap.	Comp. Motor Input	Sensible To Total Ratio (S/T)			Total Cool Cap.	Comp. Motor Input	Sensible To Total Ratio (S/T)			Total Cool Cap.	Comp. Motor Input	Sensible To Total Ratio (S/T)		
				Dry Bulb					Dry Bulb					Dry Bulb					Dry Bulb		
cfm	kBtuh	kW	75°F	80°F	85°F	kBtuh	kW	75°F	80°F	85°F	kBtuh	kW	75°F	80°F	85°F	kBtuh	kW	75°F	80°F	85°F	
63°F	4800	193.8	7.85	0.7	0.82	0.92	185.4	8.96	0.7	0.83	0.93	176.5	10.15	0.71	0.84	0.95	167.1	11.48	0.72	0.85	0.97
	6000	205	7.89	0.73	0.87	0.98	196	8.99	0.75	0.88	0.99	186.4	10.18	0.76	0.9	1	176.4	11.5	0.76	0.91	1
	7200	213.2	7.93	0.78	0.92	1	203.7	9.02	0.78	0.93	1	193.6	10.2	0.81	0.95	1	183.3	11.51	0.81	0.97	1
67°F	4800	204.8	7.89	0.55	0.67	0.78	195.9	9	0.55	0.68	0.8	186.3	10.18	0.55	0.69	0.81	176.2	11.5	0.56	0.7	0.82
	6000	215.3	7.94	0.57	0.72	0.84	205.7	9.02	0.59	0.72	0.85	195.7	10.21	0.59	0.73	0.87	184.7	11.51	0.6	0.75	0.88
	7200	223	7.97	0.61	0.76	0.89	212.8	9.05	0.6	0.77	0.9	202.3	10.23	0.61	0.78	0.92	191.3	11.53	0.62	0.79	0.94
71°F	4800	217.5	7.95	0.42	0.53	0.65	208.3	9.04	0.42	0.53	0.66	198.2	10.21	0.4	0.54	0.67	187.7	11.53	0.41	0.55	0.68
	6000	228.1	8	0.43	0.57	0.69	218.1	9.08	0.43	0.57	0.69	207.6	10.27	0.43	0.57	0.72	196.2	11.56	0.43	0.58	0.73
	7200	235.7	8.04	0.44	0.59	0.73	225.3	9.12	0.43	0.6	0.74	214.2	10.29	0.43	0.6	0.76	202.6	11.59	0.43	0.61	0.77

20 TON HIGH EFFICIENCY LCH240H4V (4 COMPRESSORS OPERATING) - VARIABLE AIR VOLUME

Entering Wet Bulb Temperature	Total Air Volume	Outdoor Air Temperature Entering Outdoor Coil																			
		85°F					95°F					105°F					115°F				
		Total Cool Cap.	Comp. Motor Input	Sensible To Total Ratio (S/T)			Total Cool Cap.	Comp. Motor Input	Sensible To Total Ratio (S/T)			Total Cool Cap.	Comp. Motor Input	Sensible To Total Ratio (S/T)			Total Cool Cap.	Comp. Motor Input	Sensible To Total Ratio (S/T)		
				Dry Bulb					Dry Bulb					Dry Bulb					Dry Bulb		
cfm	kBtuh	kW	75°F	80°F	85°F	kBtuh	kW	75°F	80°F	85°F	kBtuh	kW	75°F	80°F	85°F	kBtuh	kW	75°F	80°F	85°F	
63°F	6400	239.3	13.51	0.71	0.84	0.94	226.8	15.27	0.72	0.85	0.96	213.6	17.22	0.74	0.87	0.98	199.4	19.49	0.75	0.89	0.99
	8000	253.6	13.55	0.76	0.89	0.99	240	15.3	0.79	0.91	1	225.8	17.26	0.79	0.93	1	210.7	19.47	0.82	0.95	1
	9600	263.9	13.6	0.81	0.94	1	249.8	15.33	0.83	0.96	1	235.5	17.29	0.84	0.98	1	220.7	19.52	0.86	1	1
67°F	6400	252.7	13.55	0.56	0.69	0.81	238.7	15.3	0.55	0.7	0.82	223.8	17.25	0.56	0.71	0.84	208.4	19.48	0.57	0.74	0.86
	8000	264.1	13.59	0.59	0.74	0.87	249.5	15.33	0.59	0.76	0.88	234.4	17.28	0.6	0.78	0.9	218.8	19.51	0.6	0.8	0.92
	9600	273.4	13.64	0.62	0.8	0.92	258.5	15.36	0.63	0.82	0.94	243.2	17.32	0.63	0.84	0.96	227.4	19.56	0.65	0.84	0.98
71°F	6400	269.1	13.62	0.41	0.54	0.67	254.6	15.34	0.41	0.55	0.67	239.8	17.32	0.4	0.55	0.69	223.6	19.53	0.41	0.56	0.7
	8000	281.4	13.67	0.43	0.58	0.72	266.1	15.41	0.43	0.59	0.74	250.2	17.33	0.41	0.58	0.75	233.4	19.57	0.43	0.59	0.77
	9600	290.2	13.71	0.43	0.61	0.78	274.1	15.44	0.44	0.62	0.79	257.7	17.38	0.46	0.64	0.81	239.9	19.61	0.45	0.65	0.82

RATINGS

NOTE – For Temperatures and Capacities not shown in tables, see bulletin – Cooling Unit Rating Table Correction Factor Data in Miscellaneous Engineering Data section.

13 TON HIGH EFFICIENCY LCH156H4M (PART LOAD) - MSAV® MULTI-STAGE AIR VOLUME SUPPLY AIR BLOWER

Entering Wet Bulb Temperature	Total Air Volume	Outdoor Air Temperature Entering Outdoor Coil																			
		65°F					75°F					85°F					95°F				
		Total Cool Cap.	Comp. Motor Input	Sensible To Total Ratio (S/T)			Total Cool Cap.	Comp. Motor Input	Sensible To Total Ratio (S/T)			Total Cool Cap.	Comp. Motor Input	Sensible To Total Ratio (S/T)			Total Cool Cap.	Comp. Motor Input	Sensible To Total Ratio (S/T)		
				Dry Bulb					Dry Bulb					Dry Bulb					Dry Bulb		
cfm	kBtuh	kW	75°F	80°F	85°F	kBtuh	kW	75°F	80°F	85°F	kBtuh	kW	75°F	80°F	85°F	kBtuh	kW	75°F	80°F	85°F	
63°F	3000	98.5	4.61	0.63	0.73	0.84	92.2	5.23	0.62	0.73	0.84	85.8	5.90	0.61	0.74	0.86	78.9	6.67	0.61	0.74	0.87
	3500	104.4	4.64	0.65	0.76	0.88	97.8	5.26	0.65	0.77	0.89	91.0	5.94	0.64	0.77	0.91	83.8	6.70	0.64	0.79	0.93
	4000	109.2	4.67	0.67	0.79	0.92	102.4	5.29	0.67	0.80	0.93	95.2	5.96	0.67	0.81	0.95	87.7	6.73	0.67	0.83	0.98
67°F	3000	105.7	4.65	0.51	0.60	0.70	99.3	5.27	0.50	0.60	0.70	92.6	5.94	0.48	0.59	0.70	85.6	6.71	0.47	0.59	0.71
	3500	111.8	4.69	0.52	0.62	0.73	105.1	5.30	0.51	0.62	0.73	98.0	5.98	0.50	0.62	0.74	90.7	6.75	0.49	0.62	0.75
	4000	116.9	4.72	0.53	0.65	0.76	109.9	5.33	0.53	0.65	0.77	102.5	6.01	0.52	0.65	0.78	94.8	6.78	0.51	0.65	0.79
71°F	3000	112.9	4.69	0.40	0.49	0.58	106.3	5.31	0.39	0.48	0.58	99.4	5.99	0.37	0.47	0.57	92.2	6.75	0.35	0.46	0.57
	3500	119.3	4.73	0.41	0.51	0.60	112.3	5.35	0.39	0.50	0.60	105.1	6.03	0.38	0.49	0.60	97.4	6.79	0.36	0.48	0.60
	4000	124.5	4.77	0.41	0.52	0.62	117.3	5.38	0.40	0.51	0.62	109.7	6.06	0.39	0.51	0.63	101.7	6.83	0.37	0.50	0.63

13 TON HIGH EFFICIENCY LCH156H4M (FULL LOAD) - MSAV® MULTI-STAGE AIR VOLUME SUPPLY AIR BLOWER

Entering Wet Bulb Temperature	Total Air Volume	Outdoor Air Temperature Entering Outdoor Coil																			
		85°F					95°F					105°F					115°F				
		Total Cool Cap.	Comp. Motor Input	Sensible To Total Ratio (S/T)			Total Cool Cap.	Comp. Motor Input	Sensible To Total Ratio (S/T)			Total Cool Cap.	Comp. Motor Input	Sensible To Total Ratio (S/T)			Total Cool Cap.	Comp. Motor Input	Sensible To Total Ratio (S/T)		
				Dry Bulb					Dry Bulb					Dry Bulb					Dry Bulb		
cfm	kBtuh	kW	75°F	80°F	85°F	kBtuh	kW	75°F	80°F	85°F	kBtuh	kW	75°F	80°F	85°F	kBtuh	kW	75°F	80°F	85°F	
63°F	4160	148.1	9.05	0.70	0.85	0.99	136.5	10.20	0.71	0.87	1.00	124.5	11.51	0.72	0.9	1.00	112.1	13.01	0.73	0.93	1.00
	5200	157.1	9.11	0.76	0.94	1.00	145.1	10.26	0.77	0.96	1.00	132.6	11.57	0.79	0.99	1.00	120.5	13.08	0.81	1.00	1.00
	6240	164.5	9.17	0.82	0.99	1.00	152.7	10.32	0.83	1.00	1.00	141.1	11.64	0.86	1.00	1.00	129.1	13.15	0.89	1.00	1.00
67°F	4160	159.3	9.13	0.54	0.68	0.82	147.4	10.28	0.54	0.69	0.84	135.3	11.59	0.53	0.70	0.86	122.4	13.09	0.53	0.71	0.89
	5200	169.0	9.20	0.58	0.74	0.90	156.5	10.35	0.58	0.75	0.92	143.4	11.66	0.58	0.77	0.95	129.8	13.16	0.58	0.79	0.98
	6240	175.9	9.25	0.61	0.80	0.97	162.7	10.40	0.62	0.81	0.99	149.1	11.71	0.62	0.83	1.00	135.2	13.20	0.63	0.86	1.00
71°F	4160	170.4	9.21	0.40	0.53	0.66	158.1	10.36	0.38	0.53	0.66	145.8	11.68	0.37	0.53	0.67	132.6	13.18	0.35	0.52	0.69
	5200	180.5	9.29	0.41	0.57	0.72	167.6	10.44	0.41	0.57	0.73	154.2	11.75	0.39	0.57	0.74	140.5	13.25	0.37	0.58	0.76
	6240	187.9	9.35	0.43	0.61	0.77	174.4	10.50	0.42	0.61	0.79	160.4	11.81	0.41	0.61	0.81	146.2	13.31	0.40	0.62	0.84

15 TON HIGH EFFICIENCY LCH180H4M (PART LOAD) - MSAV® MULTI-STAGE AIR VOLUME SUPPLY AIR BLOWER

Entering Wet Bulb Temperature	Total Air Volume	Outdoor Air Temperature Entering Outdoor Coil																			
		65°F					75°F					85°F					95°F				
		Total Cool Cap.	Comp. Motor Input	Sensible To Total Ratio (S/T)			Total Cool Cap.	Comp. Motor Input	Sensible To Total Ratio (S/T)			Total Cool Cap.	Comp. Motor Input	Sensible To Total Ratio (S/T)			Total Cool Cap.	Comp. Motor Input	Sensible To Total Ratio (S/T)		
				Dry Bulb					Dry Bulb					Dry Bulb					Dry Bulb		
cfm	kBtuh	kW	75°F	80°F	85°F	kBtuh	kW	75°F	80°F	85°F	kBtuh	kW	75°F	80°F	85°F	kBtuh	kW	75°F	80°F	85°F	
63°F	3500	114.2	5.02	0.65	0.75	0.84	107.7	5.76	0.65	0.75	0.85	100.8	6.58	0.64	0.75	0.86	93.7	7.47	0.64	0.76	0.87
	4000	120.2	5.03	0.67	0.77	0.88	113.3	5.78	0.67	0.78	0.89	106.0	6.59	0.67	0.78	0.9	98.6	7.50	0.66	0.79	0.91
	4500	125.2	5.03	0.69	0.8	0.91	117.9	5.79	0.69	0.8	0.92	110.5	6.61	0.69	0.81	0.93	102.7	7.52	0.69	0.82	0.95
67°F	3500	122.4	5.03	0.53	0.63	0.72	115.6	5.78	0.52	0.62	0.72	108.6	6.60	0.51	0.62	0.72	101.1	7.51	0.5	0.62	0.73
	4000	128.6	5.04	0.54	0.64	0.74	121.4	5.79	0.53	0.64	0.75	114.1	6.62	0.53	0.64	0.75	106.3	7.53	0.52	0.64	0.76
	4500	133.7	5.04	0.55	0.66	0.77	126.3	5.81	0.55	0.66	0.77	118.7	6.64	0.54	0.66	0.78	110.6	7.55	0.53	0.67	0.79
71°F	3500	130.5	5.04	0.42	0.51	0.60	123.5	5.80	0.41	0.51	0.60	116.2	6.63	0.39	0.5	0.6	108.6	7.54	0.37	0.49	0.59
	4000	136.9	5.04	0.43	0.53	0.62	129.5	5.81	0.41	0.52	0.62	121.9	6.65	0.40	0.51	0.62	113.8	7.56	0.38	0.5	0.62
	4500	142.3	5.05	0.43	0.54	0.64	134.6	5.82	0.42	0.53	0.64	126.7	6.66	0.41	0.53	0.64	118.3	7.58	0.39	0.52	0.64

15 TON HIGH EFFICIENCY LCH180H4M (FULL LOAD) - MSAV® MULTI-STAGE AIR VOLUME SUPPLY AIR BLOWER

Entering Wet Bulb Temperature	Total Air Volume	Outdoor Air Temperature Entering Outdoor Coil																			
		85°F					95°F					105°F					115°F				
		Total Cool Cap.	Comp. Motor Input	Sensible To Total Ratio (S/T)			Total Cool Cap.	Comp. Motor Input	Sensible To Total Ratio (S/T)			Total Cool Cap.	Comp. Motor Input	Sensible To Total Ratio (S/T)			Total Cool Cap.	Comp. Motor Input	Sensible To Total Ratio (S/T)		
				Dry Bulb					Dry Bulb					Dry Bulb					Dry Bulb		
cfm	kBtuh	kW	75°F	80°F	85°F	kBtuh	kW	75°F	80°F	85°F	kBtuh	kW	75°F	80°F	85°F	kBtuh	kW	75°F	80°F	85°F	
63°F	4800	172.5	9.96	0.71	0.85	0.99	160.1	11.32	0.71	0.87	1.00	146.8	12.83	0.72	0.90	1.00	132.7	14.51	0.74	0.93	1.00
	6000	182.6	9.99	0.77	0.93	1.00	169.5	11.37	0.78	0.95	1.00	155.7	12.89	0.79	0.98	1.00	141.3	14.57	0.81	1.00	1.00
	7200	190.3	10.02	0.82	0.99	1.00	177.3	11.41	0.83	1.00	1.00	164.3	12.94	0.86	1.00	1.00	150.5	14.64	0.89	1.00	1.00
67°F	4800	185.0	10.00	0.55	0.69	0.82	172.1	11.38	0.55	0.69	0.84	158.6	12.90	0.54	0.70	0.86	144.0	14.59	0.54	0.72	0.89
	6000	195.8	10.04	0.58	0.74	0.90	182.1	11.43	0.58	0.76	0.92	167.5	12.96	0.59	0.77	0.95	152.2	14.65	0.59	0.79	0.98
	7200	203.7	10.07	0.62	0.8	0.97	189.3	11.46	0.62	0.81	0.99	173.9	13.00	0.63	0.84	1.00	157.8	14.69	0.63	0.86	1.00
71°F	4800	197.2	10.04	0.41	0.54	0.67	183.9	11.43	0.39	0.54	0.67	169.9	12.97	0.38	0.53	0.68	155.0	14.67	0.36	0.53	0.69
	6000	208.4	10.09	0.42	0.58	0.72	194.2	11.48	0.41	0.58	0.73	179.4	13.03	0.4	0.58	0.75	163.3	14.73	0.38	0.59	0.77
	7200	216.6	10.12	0.43	0.61	0.78	201.8	11.52	0.42	0.62	0.79	186.2	13.07	0.42	0.62	0.81	169.7	14.78	0.41	0.63	0.84

RATINGS

NOTE – For Temperatures and Capacities not shown in tables, see bulletin – Cooling Unit Rating Table Correction Factor Data in Miscellaneous Engineering Data section.

17.5 TON HIGH EFFICIENCY LCH210H4M (PART LOAD) - MSAV® MULTI-STAGE AIR VOLUME SUPPLY AIR BLOWER

Entering Wet Bulb Temperature	Total Air Volume	Outdoor Air Temperature Entering Outdoor Coil																			
		65°F					75°F					85°F					95°F				
		Total Cool Cap.	Comp. Motor Input	Sensible To Total Ratio (S/T)			Total Cool Cap.	Comp. Motor Input	Sensible To Total Ratio (S/T)			Total Cool Cap.	Comp. Motor Input	Sensible To Total Ratio (S/T)			Total Cool Cap.	Comp. Motor Input	Sensible To Total Ratio (S/T)		
				Dry Bulb					Dry Bulb					Dry Bulb					Dry Bulb		
cfm	kBtuh	kW	75°F	80°F	85°F	kBtuh	kW	75°F	80°F	85°F	kBtuh	kW	75°F	80°F	85°F	kBtuh	kW	75°F	80°F	85°F	
63°F	4000	128.7	5.41	0.66	0.77	0.87	121.1	6.15	0.65	0.77	0.89	113.4	6.96	0.65	0.78	0.90	105.1	7.88	0.65	0.79	0.92
	4750	136.2	5.45	0.68	0.80	0.92	128.2	6.19	0.68	0.81	0.94	119.8	7.01	0.69	0.83	0.96	111.0	7.93	0.69	0.84	0.98
	5500	142.2	5.48	0.71	0.84	0.97	133.7	6.23	0.71	0.85	0.99	124.9	7.05	0.72	0.87	1.00	115.8	7.96	0.73	0.89	1.00
67°F	4000	138.9	5.46	0.53	0.63	0.73	130.9	6.21	0.52	0.63	0.74	122.6	7.03	0.51	0.63	0.74	114.1	7.95	0.51	0.63	0.75
	4750	146.6	5.51	0.55	0.66	0.77	138.2	6.26	0.54	0.66	0.78	129.5	7.08	0.54	0.66	0.79	120.2	8.00	0.53	0.67	0.81
	5500	152.8	5.55	0.56	0.69	0.81	143.8	6.30	0.56	0.69	0.82	134.7	7.12	0.55	0.70	0.84	125.2	8.04	0.56	0.71	0.85
71°F	4000	149.1	5.52	0.41	0.51	0.61	141.2	6.28	0.40	0.51	0.61	132.3	7.10	0.39	0.50	0.61	123.4	8.02	0.38	0.49	0.61
	4750	157.4	5.58	0.42	0.53	0.64	148.4	6.33	0.41	0.53	0.64	139.4	7.16	0.40	0.53	0.64	129.6	8.07	0.39	0.52	0.65
	5500	163.6	5.62	0.43	0.55	0.66	154.3	6.38	0.42	0.55	0.67	144.6	7.20	0.41	0.54	0.67	134.7	8.12	0.40	0.55	0.68

17.5 TON HIGH EFFICIENCY LCH210H4M (FULL LOAD) - MSAV® MULTI-STAGE AIR VOLUME SUPPLY AIR BLOWER

Entering Wet Bulb Temperature	Total Air Volume	Outdoor Air Temperature Entering Outdoor Coil																			
		85°F					95°F					105°F					115°F				
		Total Cool Cap.	Comp. Motor Input	Sensible To Total Ratio (S/T)			Total Cool Cap.	Comp. Motor Input	Sensible To Total Ratio (S/T)			Total Cool Cap.	Comp. Motor Input	Sensible To Total Ratio (S/T)			Total Cool Cap.	Comp. Motor Input	Sensible To Total Ratio (S/T)		
				Dry Bulb					Dry Bulb					Dry Bulb					Dry Bulb		
cfm	kBtuh	kW	75°F	80°F	85°F	kBtuh	kW	75°F	80°F	85°F	kBtuh	kW	75°F	80°F	85°F	kBtuh	kW	75°F	80°F	85°F	
63°F	5600	197.5	11.26	0.71	0.86	0.99	183.2	12.71	0.73	0.89	1.00	168.8	14.37	0.74	0.91	1.00	153.6	16.25	0.75	0.94	1.00
	7000	209.3	11.34	0.78	0.95	1.00	194.5	12.8	0.79	0.97	1.00	179.6	14.45	0.81	0.99	1.00	164.6	16.33	0.83	1.00	1.00
	8400	219.3	11.42	0.83	0.99	1.00	205.2	12.89	0.85	1.00	1.00	190.5	14.55	0.88	1.00	1.00	175.2	16.42	0.91	1.00	1.00
67°F	5600	212.6	11.36	0.55	0.69	0.83	198.1	12.83	0.55	0.70	0.85	182.6	14.48	0.55	0.71	0.87	166.4	16.34	0.55	0.73	0.90
	7000	224.4	11.46	0.59	0.76	0.91	208.9	12.92	0.60	0.77	0.94	192.3	14.56	0.60	0.79	0.96	175.2	16.41	0.60	0.81	0.98
	8400	232.7	11.52	0.62	0.81	0.98	216.2	12.98	0.63	0.83	0.99	199.3	14.62	0.64	0.85	1.00	181.7	16.47	0.64	0.88	1.00
71°F	5600	228.4	11.49	0.41	0.54	0.67	212.9	12.95	0.40	0.54	0.68	197.0	14.60	0.39	0.55	0.69	180.1	16.46	0.38	0.55	0.71
	7000	240.3	11.59	0.42	0.59	0.73	223.9	13.05	0.42	0.59	0.75	206.9	14.69	0.41	0.59	0.76	189.0	16.54	0.40	0.60	0.78
	8400	248.5	11.66	0.44	0.62	0.79	231.5	13.12	0.44	0.63	0.81	214.0	14.75	0.43	0.64	0.83	195.1	16.60	0.42	0.64	0.86

20 TON HIGH EFFICIENCY LCH240H4M (PART LOAD) - MSAV® MULTI-STAGE AIR VOLUME SUPPLY AIR BLOWER

Entering Wet Bulb Temperature	Total Air Volume	Outdoor Air Temperature Entering Outdoor Coil																			
		65°F					75°F					85°F					95°F				
		Total Cool Cap.	Comp. Motor Input	Sensible To Total Ratio (S/T)			Total Cool Cap.	Comp. Motor Input	Sensible To Total Ratio (S/T)			Total Cool Cap.	Comp. Motor Input	Sensible To Total Ratio (S/T)			Total Cool Cap.	Comp. Motor Input	Sensible To Total Ratio (S/T)		
				Dry Bulb					Dry Bulb					Dry Bulb					Dry Bulb		
cfm	kBtuh	kW	75°F	80°F	85°F	kBtuh	kW	75°F	80°F	85°F	kBtuh	kW	75°F	80°F	85°F	kBtuh	kW	75°F	80°F	85°F	
63°F	4500	116.8	5.07	0.64	0.74	0.84	111.1	5.77	0.64	0.75	0.85	105.1	6.55	0.64	0.75	0.87	98.7	7.43	0.64	0.76	0.88
	5500	124.7	5.12	0.66	0.78	0.90	118.5	5.83	0.67	0.79	0.91	111.8	6.60	0.67	0.80	0.93	104.9	7.48	0.68	0.82	0.95
	6500	130.6	5.16	0.69	0.82	0.95	124.0	5.87	0.70	0.84	0.96	117.1	6.64	0.70	0.85	0.98	109.7	7.52	0.71	0.87	0.99
67°F	4500	125.3	5.12	0.52	0.61	0.71	119.3	5.83	0.52	0.61	0.71	113.0	6.61	0.51	0.62	0.72	106.2	7.49	0.51	0.62	0.73
	5500	133.4	5.18	0.53	0.64	0.75	126.9	5.89	0.53	0.64	0.76	120.0	6.67	0.53	0.65	0.77	112.8	7.55	0.53	0.65	0.78
	6500	139.7	5.22	0.55	0.67	0.79	132.7	5.93	0.55	0.68	0.80	125.2	6.71	0.55	0.68	0.82	117.4	7.59	0.55	0.69	0.83
71°F	4500	133.9	5.18	0.41	0.50	0.59	127.5	5.89	0.40	0.50	0.59	120.9	6.68	0.39	0.50	0.59	113.7	7.55	0.39	0.49	0.59
	5500	142.3	5.24	0.42	0.52	0.62	135.3	5.95	0.41	0.52	0.62	128.2	6.74	0.40	0.52	0.62	120.8	7.62	0.40	0.52	0.63
	6500	148.8	5.29	0.42	0.54	0.64	141.3	6.01	0.42	0.54	0.65	133.7	6.79	0.41	0.54	0.66	125.4	7.66	0.41	0.54	0.67

20 TON HIGH EFFICIENCY LCH240H4M (FULL LOAD) - MSAV® MULTI-STAGE AIR VOLUME SUPPLY AIR BLOWER

Entering Wet Bulb Temperature	Total Air Volume	Outdoor Air Temperature Entering Outdoor Coil																			
		85°F					95°F					105°F					115°F				
		Total Cool Cap.	Comp. Motor Input	Sensible To Total Ratio (S/T)			Total Cool Cap.	Comp. Motor Input	Sensible To Total Ratio (S/T)			Total Cool Cap.	Comp. Motor Input	Sensible To Total Ratio (S/T)			Total Cool Cap.	Comp. Motor Input	Sensible To Total Ratio (S/T)		
				Dry Bulb					Dry Bulb					Dry Bulb					Dry Bulb		
cfm	kBtuh	kW	75°F	80°F	85°F	kBtuh	kW	75°F	80°F	85°F	kBtuh	kW	75°F	80°F	85°F	kBtuh	kW	75°F	80°F	85°F	
63°F	6400	236.6	13.31	0.73	0.88	1.00	221.6	15.06	0.74	0.91	1.00	205.8	17.06	0.76	0.94	1.00	189.2	19.35	0.78	0.97	1.00
	8000	249.2	13.43	0.79	0.97	1.00	233.7	15.17	0.80	0.98	1.00	217.5	17.17	0.83	0.99	1.00	201.1	19.47	0.86	1.00	1.00
	9600	260.1	13.53	0.85	1.00	1.00	244.7	15.28	0.87	1.00	1.00	228.9	17.29	0.90	1.00	1.00	212.1	19.59	0.94	1.00	1.00
67°F	6400	252.7	13.46	0.56	0.71	0.85	236.8	15.20	0.57	0.72	0.87	220.0	17.20	0.57	0.73	0.90	202.2	19.48	0.58	0.76	0.93
	8000	264.4	13.57	0.60	0.77	0.93	247.3	15.31	0.61	0.78	0.96	229.6	17.30	0.62	0.81	0.98	210.9	19.57	0.63	0.84	0.99
	9600	272.8	13.66	0.64	0.83	0.99	255.3	15.39	0.64	0.85	1.00	236.8	17.38	0.65	0.88	1.00	217.9	19.65	0.67	0.92	1.00
71°F	6400	269.2	13.62	0.41	0.55	0.68	252.6	15.37	0.41	0.56	0.70	235.2	17.36	0.41	0.56	0.71	216.6	19.64	0.40	0.57	0.73
	8000	281.5	13.75	0.43	0.59	0.74	263.7	15.49	0.43	0.60	0.76	245.0	17.48	0.43	0.61	0.78	225.2	19.74	0.42	0.62	0.81
	9600	289.9	13.83	0.45	0.63	0.81	271.3	15.57	0.45	0.64	0.83	252.0	17.55	0.45	0.65	0.86	231.3	19.81	0.44	0.67	0.89

RATINGS

NOTE – For Temperatures and Capacities not shown in tables, see bulletin – Cooling Unit Rating Table Correction Factor Data in Miscellaneous Engineering Data section.

25 TON STANDARD EFFICIENCY LCH300S4M (PART LOAD) - MSAV® MULTI-STAGE AIR VOLUME SUPPLY AIR BLOWER

Entering Wet Bulb Temperature	Total Air Volume	Outdoor Air Temperature Entering Outdoor Coil																							
		65°F						75°F						85°F						95°F					
		Total Cool Cap.	Comp. Motor Input	Sensible To Total Ratio (S/T)			Total Cool Cap.	Comp. Motor Input	Sensible To Total Ratio (S/T)			Total Cool Cap.	Comp. Motor Input	Sensible To Total Ratio (S/T)			Total Cool Cap.	Comp. Motor Input	Sensible To Total Ratio (S/T)						
				Dry Bulb					Dry Bulb					Dry Bulb					Dry Bulb						
		cfm	kBtuh	kW	75°F	80°F	85°F	kBtuh	kW	75°F	80°F	85°F	kBtuh	kW	75°F	80°F	85°F	kBtuh	kW	75°F	80°F	85°F			
63°F	5750	135.3	6.25	0.65	0.75	0.86	130.0	7.06	0.66	0.77	0.88	124.8	7.98	0.66	0.78	0.89	119.7	9.04	0.67	0.79	0.91				
	6750	141.3	6.30	0.67	0.79	0.90	135.5	7.12	0.68	0.80	0.92	129.8	8.04	0.69	0.82	0.94	124.3	9.10	0.70	0.83	0.96				
	7750	146.0	6.35	0.69	0.82	0.94	139.8	7.17	0.70	0.84	0.96	133.9	8.09	0.72	0.86	0.98	128.1	9.14	0.73	0.87	0.99				
67°F	5750	143.5	6.32	0.53	0.62	0.72	138.1	7.15	0.53	0.63	0.73	132.4	8.07	0.54	0.64	0.74	126.9	9.13	0.54	0.65	0.76				
	6750	149.9	6.39	0.54	0.64	0.75	143.6	7.21	0.54	0.65	0.77	137.7	8.14	0.55	0.67	0.78	131.9	9.19	0.56	0.67	0.80				
	7750	155.1	6.44	0.55	0.67	0.79	148.1	7.26	0.56	0.68	0.81	141.9	8.19	0.57	0.69	0.82	135.7	9.25	0.57	0.71	0.84				
71°F	5750	151.7	6.41	0.42	0.51	0.60	145.6	7.24	0.42	0.51	0.61	140.1	8.17	0.42	0.52	0.61	134.2	9.23	0.42	0.52	0.62				
	6750	158.3	6.48	0.42	0.52	0.62	151.7	7.31	0.42	0.53	0.63	145.6	8.24	0.42	0.53	0.64	139.7	9.30	0.42	0.54	0.65				
	7750	164.2	6.54	0.42	0.54	0.64	156.7	7.37	0.41	0.54	0.65	150.2	8.30	0.42	0.55	0.67	143.3	9.35	0.43	0.56	0.68				

25 TON STANDARD EFFICIENCY LCH300S4M (FULL LOAD) - MSAV® MULTI-STAGE AIR VOLUME SUPPLY AIR BLOWER

Entering Wet Bulb Temperature	Total Air Volume	Outdoor Air Temperature Entering Outdoor Coil																							
		85°F						95°F						105°F						115°F					
		Total Cool Cap.	Comp. Motor Input	Sensible To Total Ratio (S/T)			Total Cool Cap.	Comp. Motor Input	Sensible To Total Ratio (S/T)			Total Cool Cap.	Comp. Motor Input	Sensible To Total Ratio (S/T)			Total Cool Cap.	Comp. Motor Input	Sensible To Total Ratio (S/T)						
				Dry Bulb					Dry Bulb					Dry Bulb					Dry Bulb						
		cfm	kBtuh	kW	75°F	80°F	85°F	kBtuh	kW	75°F	80°F	85°F	kBtuh	kW	75°F	80°F	85°F	kBtuh	kW	75°F	80°F	85°F			
63°F	8000	277.2	17.80	0.72	0.87	1.00	264.6	19.95	0.74	0.89	1.00	251.7	22.43	0.75	0.92	1.00	238.5	25.35	0.78	0.95	1.00				
	9500	287.2	17.97	0.76	0.93	1.00	273.8	20.12	0.78	0.96	1.00	260.1	22.59	0.80	0.98	1.00	246.0	25.49	0.83	1.00	1.00				
	11000	295.0	18.11	0.80	0.98	1.00	280.6	20.25	0.83	1.00	1.00	267.4	22.73	0.85	1.00	1.00	254.5	25.68	0.88	1.00	1.00				
67°F	8000	293.2	18.08	0.57	0.70	0.83	279.6	20.23	0.58	0.71	0.86	265.8	22.71	0.59	0.73	0.88	251.7	25.63	0.60	0.75	0.91				
	9500	302.9	18.25	0.59	0.74	0.89	288.4	20.39	0.60	0.76	0.92	273.9	22.86	0.62	0.78	0.95	258.8	25.78	0.63	0.80	0.98				
	11000	310.1	18.38	0.62	0.78	0.95	295.3	20.52	0.63	0.80	0.98	279.9	22.99	0.64	0.83	1.00	264.5	25.89	0.65	0.85	1.00				
71°F	8000	310.0	18.38	0.43	0.56	0.68	295.5	20.53	0.43	0.57	0.69	280.6	23.00	0.43	0.58	0.71	265.8	25.92	0.44	0.59	0.73				
	9500	319.0	18.54	0.44	0.58	0.72	304.0	20.68	0.44	0.59	0.74	288.9	23.17	0.45	0.61	0.75	273.0	26.07	0.45	0.62	0.78				
	11000	326.9	18.68	0.44	0.61	0.76	311.2	20.82	0.45	0.62	0.78	294.9	23.29	0.46	0.63	0.80	278.5	26.19	0.47	0.65	0.83				

HUMIDITROL® DEHUMIDIFICATION SYSTEM RATINGS

13 TON HIGH EFFICIENCY LCH156H4B WITH HUMIDITROL® OPERATING (PART LOAD) - CONSTANT AIR VOLUME

Entering Wet Bulb Temperature	Total Air Volume	Outdoor Air Temperature Entering Outdoor Coil																			
		65°F					75°F					85°F					95°F				
		Total Cool Cap.	Comp. Motor Input	Sensible To Total Ratio (S/T)			Total Cool Cap.	Comp. Motor Input	Sensible To Total Ratio (S/T)			Total Cool Cap.	Comp. Motor Input	Sensible To Total Ratio (S/T)			Total Cool Cap.	Comp. Motor Input	Sensible To Total Ratio (S/T)		
				Dry Bulb					Dry Bulb					Dry Bulb					Dry Bulb		
cfm	kBtuh	kW	75°F	80°F	85°F	kBtuh	kW	75°F	80°F	85°F	kBtuh	kW	75°F	80°F	85°F	kBtuh	kW	75°F	80°F	85°F	
63°F	4160	78.9	4.67	.56	.74	.93	66.3	5.28	.50	.73	.96	53.6	5.89	.45	.72	.99	40.9	6.50	.39	.71	1.00
	5200	86.8	4.71	.58	.80	1.00	72.5	5.30	.52	.79	1.00	58.1	5.89	.47	.78	1.00	43.7	6.48	.41	.77	1.00
	6240	94.7	4.74	.60	.86	1.00	78.7	5.32	.54	.85	1.00	62.6	5.89	.49	.83	1.00	46.6	6.47	.43	.82	1.00
67°F	4160	89.4	4.76	.40	.57	.74	77.1	5.37	.33	.53	.74	64.8	5.98	.26	.49	.73	52.5	6.59	.18	.46	.73
	5200	97.5	4.77	.41	.61	.80	83.6	5.38	.34	.57	.80	69.6	5.98	.26	.53	.80	55.7	6.58	.18	.49	.81
	6240	105.7	4.79	.43	.64	.86	90.1	5.38	.34	.60	.87	74.5	5.98	.26	.57	.88	58.9	6.57	.17	.53	.89
71°F	4160	99.9	4.85	.25	.40	.55	87.9	5.46	.16	.33	.51	76.0	6.07	.07	.27	.47	64.1	6.69	-.03	.20	.43
	5200	108.2	4.84	.25	.41	.58	94.7	5.45	.15	.35	.55	81.2	6.07	.05	.28	.52	67.7	6.68	-.06	.22	.49
	6240	116.6	4.84	.25	.43	.61	101.5	5.45	.14	.36	.59	86.4	6.06	.03	.30	.57	71.3	6.68	-.09	.23	.55

13 TON HIGH EFFICIENCY LCH156H4B WITH HUMIDITROL® OPERATING (FULL LOAD) - CONSTANT AIR VOLUME

Entering Wet Bulb Temperature	Total Air Volume	Outdoor Air Temperature Entering Outdoor Coil																			
		65°F					75°F					85°F					95°F				
		Total Cool Cap.	Comp. Motor Input	Sensible To Total Ratio (S/T)			Total Cool Cap.	Comp. Motor Input	Sensible To Total Ratio (S/T)			Total Cool Cap.	Comp. Motor Input	Sensible To Total Ratio (S/T)			Total Cool Cap.	Comp. Motor Input	Sensible To Total Ratio (S/T)		
				Dry Bulb					Dry Bulb					Dry Bulb					Dry Bulb		
cfm	kBtuh	kW	75°F	80°F	85°F	kBtuh	kW	75°F	80°F	85°F	kBtuh	kW	75°F	80°F	85°F	kBtuh	kW	75°F	80°F	85°F	
63°F	4160	131.1	7.12	.64	.82	1.00	116.4	8.10	.62	.83	1.00	101.6	9.08	.60	.84	1.00	86.8	10.05	.57	.85	1.00
	5200	142.5	7.16	.67	.87	1.00	125.8	8.14	.66	.89	1.00	109.2	9.11	.65	.90	1.00	92.6	10.09	.64	.91	1.00
	6240	153.8	7.20	.71	.93	1.00	135.3	8.17	.71	.94	1.00	116.8	9.15	.71	.96	1.00	98.3	10.12	.71	.98	1.00
67°F	4160	148.3	7.23	.47	.63	.79	132.8	8.20	.44	.62	.81	117.3	9.18	.41	.61	.82	101.8	10.15	.37	.61	.84
	5200	160.5	7.28	.49	.67	.85	143.0	8.25	.46	.67	.87	125.4	9.22	.44	.66	.88	107.8	10.19	.41	.65	.90
	6240	172.8	7.33	.51	.71	.91	153.1	8.30	.49	.71	.92	133.5	9.26	.47	.70	.94	113.8	10.23	.44	.70	.96
71°F	4160	165.4	7.34	.31	.45	.59	149.2	8.31	.26	.42	.58	133.0	9.28	.22	.39	.57	116.8	10.24	.17	.36	.56
	5200	178.6	7.40	.31	.47	.63	160.1	8.37	.27	.44	.62	141.6	9.33	.22	.42	.62	123.0	10.29	.17	.39	.62
	6240	191.8	7.46	.32	.49	.67	171.0	8.42	.27	.47	.67	150.1	9.38	.22	.45	.67	129.2	10.34	.17	.42	.68

15 TON HIGH EFFICIENCY LCH180H4B WITH HUMIDITROL® OPERATING (PART LOAD) - CONSTANT AIR VOLUME

Entering Wet Bulb Temperature	Total Air Volume	Outdoor Air Temperature Entering Outdoor Coil																			
		65°F					75°F					85°F					95°F				
		Total Cool Cap.	Comp. Motor Input	Sensible To Total Ratio (S/T)			Total Cool Cap.	Comp. Motor Input	Sensible To Total Ratio (S/T)			Total Cool Cap.	Comp. Motor Input	Sensible To Total Ratio (S/T)			Total Cool Cap.	Comp. Motor Input	Sensible To Total Ratio (S/T)		
				Dry Bulb					Dry Bulb					Dry Bulb					Dry Bulb		
cfm	kBtuh	kW	75°F	80°F	85°F	kBtuh	kW	75°F	80°F	85°F	kBtuh	kW	75°F	80°F	85°F	kBtuh	kW	75°F	80°F	85°F	
63°F	4800	91.6	5.36	.56	.74	.91	78.7	6.02	.51	.73	.94	65.8	6.67	.46	.71	.96	52.8	7.33	.41	.70	.98
	6000	97.3	5.40	.60	.80	1.00	82.5	6.03	.56	.81	1.00	67.7	6.65	.53	.82	1.00	52.9	7.28	.49	.83	1.00
	7200	103.0	5.44	.63	.87	1.00	86.4	6.04	.61	.90	1.00	69.7	6.64	.59	.94	1.00	53.0	7.23	.57	.97	1.00
67°F	4800	103.7	5.47	.41	.57	.72	90.4	6.13	.34	.53	.72	77.0	6.78	.28	.49	.71	63.6	7.44	.21	.46	.71
	6000	108.5	5.51	.43	.61	.79	94.0	6.14	.37	.59	.81	79.5	6.76	.31	.56	.82	65.0	7.39	.25	.54	.84
	7200	113.3	5.54	.44	.65	.86	97.6	6.14	.39	.64	.90	82.0	6.75	.33	.63	.93	66.3	7.35	.28	.63	.97
71°F	4800	115.9	5.58	.25	.39	.53	102.1	6.24	.17	.33	.50	88.2	6.90	.09	.28	.46	74.4	7.55	.01	.22	.43
	6000	119.7	5.61	.25	.41	.57	105.5	6.24	.17	.36	.55	91.2	6.87	.08	.30	.52	77.0	7.51	.00	.25	.50
	7200	123.5	5.64	.25	.43	.61	108.9	6.25	.17	.38	.60	94.2	6.85	.08	.33	.58	79.6	7.46	-.01	.28	.57

15 TON HIGH EFFICIENCY LCH180H4B WITH HUMIDITROL® OPERATING (FULL LOAD) - CONSTANT AIR VOLUME

Entering Wet Bulb Temperature	Total Air Volume	Outdoor Air Temperature Entering Outdoor Coil																			
		65°F					75°F					85°F					95°F				
		Total Cool Cap.	Comp. Motor Input	Sensible To Total Ratio (S/T)			Total Cool Cap.	Comp. Motor Input	Sensible To Total Ratio (S/T)			Total Cool Cap.	Comp. Motor Input	Sensible To Total Ratio (S/T)			Total Cool Cap.	Comp. Motor Input	Sensible To Total Ratio (S/T)		
				Dry Bulb					Dry Bulb					Dry Bulb					Dry Bulb		
cfm	kBtuh	kW	75°F	80°F	85°F	kBtuh	kW	75°F	80°F	85°F	kBtuh	kW	75°F	80°F	85°F	kBtuh	kW	75°F	80°F	85°F	
63°F	4800	154.5	8.08	.64	.80	.96	138.5	9.09	.63	.81	.99	122.4	10.11	.62	.82	1.00	106.3	11.13	.61	.83	1.00
	6000	163.3	8.13	.69	.87	1.00	144.9	9.13	.69	.89	1.00	126.4	10.12	.69	.90	1.00	108.0	11.12	.69	.92	1.00
	7200	172.0	8.18	.73	.94	1.00	151.3	9.16	.74	.96	1.00	130.5	10.14	.75	.98	1.00	109.7	11.12	.76	1.00	1.00
67°F	4800	171.4	8.23	.48	.62	.77	155.1	9.24	.45	.62	.79	138.8	10.25	.42	.61	.80	122.6	11.26	.39	.60	.81
	6000	180.3	8.27	.50	.65	.80	161.9	9.27	.48	.65	.83	143.5	10.27	.46	.66	.86	125.1	11.26	.44	.67	.90
	7200	189.2	8.31	.53	.67	.82	168.7	9.30	.51	.69	.87	148.2	10.28	.49	.71	.93	127.7	11.26	.48	.73	.98
71°F	4800	188.2	8.38	.31	.45	.59	171.7	9.39	.27	.42	.58	155.3	10.39	.23	.40	.57	138.9	11.40	.18	.37	.56
	6000	197.3	8.41	.31	.43	.54	179.0	9.41	.27	.42	.57	160.6	10.41	.23	.42	.61	142.3	11.40	.19	.41	.64
	7200	206.4	8.45	.32	.40	.49	186.2	9.43	.27	.42	.57	165.9	10.42	.23	.44	.65	145.7	11.41	.19	.46	.72

HUMIDITROL® DEHUMIDIFICATION SYSTEM RATINGS

17.5 TON HIGH EFFICIENCY LCH210H4 WITH HUMIDITROL® OPERATING (PART LOAD)

Entering Wet Bulb Temperature	Total Air Volume	Outdoor Air Temperature Entering Outdoor Coil																			
		65°F					75°F					85°F					95°F				
		Total Cool Cap.	Comp. Motor Input	Sensible To Total Ratio (S/T)			Total Cool Cap.	Comp. Motor Input	Sensible To Total Ratio (S/T)			Total Cool Cap.	Comp. Motor Input	Sensible To Total Ratio (S/T)			Total Cool Cap.	Comp. Motor Input	Sensible To Total Ratio (S/T)		
				Dry Bulb					Dry Bulb					Dry Bulb					Dry Bulb		
cfm	kBtuh	kW	75°F	80°F	85°F	kBtuh	kW	75°F	80°F	85°F	kBtuh	kW	75°F	80°F	85°F	kBtuh	kW	75°F	80°F	85°F	
63°F	5600	105.3	5.76	.58	.77	.96	91.1	6.45	.53	.75	.98	76.8	7.14	.48	.74	1.00	62.6	7.84	.43	.72	1.00
	7000	109.7	5.79	.63	.85	1.00	92.9	6.47	.60	.85	1.00	76.1	7.14	.57	.86	1.00	59.3	7.82	.54	.86	1.00
	8400	114.0	5.82	.68	.93	1.00	94.7	6.48	.67	.95	1.00	75.3	7.14	.65	.98	1.00	56.0	7.81	.64	1.00	1.00
67°F	5600	120.6	5.91	.42	.59	.77	105.7	6.59	.35	.55	.76	90.7	7.27	.29	.52	.74	75.8	7.95	.23	.48	.73
	7000	126.6	5.95	.45	.64	.83	108.8	6.62	.39	.62	.84	91.0	7.28	.33	.59	.86	73.1	7.95	.27	.57	.87
	8400	132.7	5.99	.47	.69	.90	111.9	6.64	.42	.68	.93	91.2	7.29	.37	.67	.97	70.5	7.94	.32	.66	1.00
71°F	5600	135.8	6.07	.26	.42	.58	120.2	6.74	.18	.36	.53	104.7	7.40	.10	.30	.49	89.1	8.06	.02	.23	.45
	7000	143.6	6.11	.26	.43	.60	124.7	6.77	.18	.38	.58	105.9	7.42	.10	.33	.56	87.0	8.07	.01	.28	.55
	8400	151.3	6.16	.27	.44	.62	129.2	6.80	.18	.40	.63	107.1	7.44	.09	.36	.64	84.9	8.08	.00	.32	.65

17.5 TON HIGH EFFICIENCY LCH210H4 WITH HUMIDITROL® OPERATING (FULL LOAD)

Entering Wet Bulb Temperature	Total Air Volume	Outdoor Air Temperature Entering Outdoor Coil																			
		65°F					75°F					85°F					95°F				
		Total Cool Cap.	Comp. Motor Input	Sensible To Total Ratio (S/T)			Total Cool Cap.	Comp. Motor Input	Sensible To Total Ratio (S/T)			Total Cool Cap.	Comp. Motor Input	Sensible To Total Ratio (S/T)			Total Cool Cap.	Comp. Motor Input	Sensible To Total Ratio (S/T)		
				Dry Bulb					Dry Bulb					Dry Bulb					Dry Bulb		
cfm	kBtuh	kW	75°F	80°F	85°F	kBtuh	kW	75°F	80°F	85°F	kBtuh	kW	75°F	80°F	85°F	kBtuh	kW	75°F	80°F	85°F	
63°F	5600	179.3	9.23	.65	.81	.98	162.1	10.35	.63	.82	1.00	144.9	11.47	.62	.83	1.00	127.6	12.60	.60	.83	1.00
	7000	189.8	9.32	.69	.87	1.00	170.6	10.43	.68	.88	1.00	151.4	11.54	.67	.89	1.00	132.2	12.64	.66	.90	1.00
	8400	200.2	9.42	.74	.94	1.00	179.0	10.51	.73	.95	1.00	157.9	11.60	.73	.96	1.00	136.7	12.69	.72	.98	1.00
67°F	5600	199.6	9.47	.48	.63	.79	181.4	10.58	.45	.62	.80	163.2	11.68	.43	.62	.81	144.9	12.78	.40	.61	.81
	7000	210.4	9.58	.51	.68	.85	190.2	10.67	.48	.67	.87	170.0	11.75	.46	.67	.88	149.8	12.84	.44	.66	.89
	8400	221.3	9.68	.54	.73	.92	199.1	10.76	.51	.72	.94	176.9	11.83	.49	.72	.95	154.6	12.91	.47	.72	.97
71°F	5600	219.9	9.72	.31	.45	.60	200.7	10.80	.28	.43	.59	181.5	11.88	.24	.41	.58	162.2	12.96	.20	.39	.57
	7000	231.1	9.83	.32	.48	.65	209.9	10.90	.28	.46	.64	188.6	11.97	.25	.44	.64	167.4	13.04	.21	.42	.64
	8400	242.4	9.93	.33	.52	.70	219.1	11.00	.29	.50	.70	195.8	12.06	.25	.48	.71	172.6	13.13	.21	.46	.71

20 TON HIGH EFFICIENCY LCH240H4 WITH HUMIDITROL® OPERATING (PART LOAD)

Entering Wet Bulb Temperature	Total Air Volume	Outdoor Air Temperature Entering Outdoor Coil																			
		65°F					75°F					85°F					95°F				
		Total Cool Cap.	Comp. Motor Input	Sensible To Total Ratio (S/T)			Total Cool Cap.	Comp. Motor Input	Sensible To Total Ratio (S/T)			Total Cool Cap.	Comp. Motor Input	Sensible To Total Ratio (S/T)			Total Cool Cap.	Comp. Motor Input	Sensible To Total Ratio (S/T)		
				Dry Bulb					Dry Bulb					Dry Bulb					Dry Bulb		
cfm	kBtuh	kW	75°F	80°F	85°F	kBtuh	kW	75°F	80°F	85°F	kBtuh	kW	75°F	80°F	85°F	kBtuh	kW	75°F	80°F	85°F	
63°F	6400	91.1	5.34	.52	.70	.88	75.6	5.99	.43	.68	.93	60.0	6.63	.34	.66	.97	44.4	7.28	.25	.64	1.00
	8000	98.6	5.37	.54	.76	.97	80.6	5.99	.47	.76	1.00	62.7	6.61	.39	.77	1.00	44.7	7.23	.31	.78	1.00
	9600	106.1	5.40	.57	.82	1.00	85.7	5.99	.50	.85	1.00	65.3	6.59	.43	.88	1.00	45.0	7.19	.36	.92	1.00
67°F	6400	106.4	5.48	.37	.52	.68	89.5	6.12	.27	.48	.69	72.6	6.76	.17	.43	.69	55.7	7.40	.07	.38	.69
	8000	112.6	5.50	.38	.57	.75	94.4	6.12	.28	.53	.78	76.2	6.74	.18	.49	.80	58.0	7.36	.09	.46	.83
	9600	118.9	5.52	.39	.61	.82	99.3	6.12	.30	.58	.87	79.7	6.72	.20	.56	.92	60.2	7.32	.11	.54	.96
71°F	6400	121.7	5.62	.22	.35	.49	103.5	6.25	.10	.28	.45	85.3	6.88	-.01	.20	.40	67.1	7.52	-.12	.12	.36
	8000	126.7	5.63	.22	.38	.54	108.2	6.25	.10	.30	.49	89.7	6.87	-.02	.22	.45	71.2	7.49	-.13	.14	.41
	9600	131.6	5.64	.21	.40	.58	112.9	6.25	.09	.32	.54	94.1	6.85	-.02	.24	.49	75.4	7.46	-.14	.15	.45

20 TON HIGH EFFICIENCY LCH240H4 WITH HUMIDITROL® OPERATING (FULL LOAD)

Entering Wet Bulb Temperature	Total Air Volume	Outdoor Air Temperature Entering Outdoor Coil																			
		65°F					75°F					85°F					95°F				
		Total Cool Cap.	Comp. Motor Input	Sensible To Total Ratio (S/T)			Total Cool Cap.	Comp. Motor Input	Sensible To Total Ratio (S/T)			Total Cool Cap.	Comp. Motor Input	Sensible To Total Ratio (S/T)			Total Cool Cap.	Comp. Motor Input	Sensible To Total Ratio (S/T)		
				Dry Bulb					Dry Bulb					Dry Bulb					Dry Bulb		
cfm	kBtuh	kW	75°F	80°F	85°F	kBtuh	kW	75°F	80°F	85°F	kBtuh	kW	75°F	80°F	85°F	kBtuh	kW	75°F	80°F	85°F	
63°F	6400	215.7	10.70	.64	.79	.93	193.6	12.10	.63	.81	.99	171.4	13.50	.62	.84	1.00	149.3	14.90	.61	.86	1.00
	8000	226.5	10.73	.69	.86	1.00	201.6	12.10	.69	.88	1.00	176.6	13.48	.70	.91	1.00	151.7	14.86	.70	.93	1.00
	9600	237.4	10.76	.73	.94	1.00	209.6	12.11	.75	.96	1.00	181.8	13.46	.77	.98	1.00	154.0	14.81	.80	1.00	1.00
67°F	6400	240.5	10.89	.48	.62	.76	217.4	12.29	.46	.62	.79	194.3	13.69	.44	.63	.82	171.2	15.10	.42	.63	.85
	8000	249.1	10.91	.51	.67	.84	224.6	12.30	.49	.68	.86	200.1	13.69	.48	.68	.88	175.7	15.08	.46	.68	.91
	9600	257.6	10.94	.53	.73	.92	231.8	12.31	.53	.73	.93	206.0	13.68	.52	.73	.95	180.1	15.05	.51	.74	.96
71°F	6400	265.4	11.07	.32	.45	.58	241.3	12.48	.29	.44	.59	217.2	13.88	.25	.42	.59	193.1	15.29	.22	.40	.59
	8000	271.6	11.10	.33	.49	.64	247.6	12.50	.29	.47	.65	223.6	13.89	.26	.45	.65	199.6	15.29	.22	.44	.66
	9600	277.8	11.12	.34	.52	.70	254.0	12.51	.30	.50	.70	230.1	13.90	.26	.49	.71	206.2	15.29	.22	.47	.72

HUMIDITROL® DEHUMIDIFICATION SYSTEM RATINGS

25 TON STANDARD EFFICIENCY LCH300S4 WITH HUMIDITROL® OPERATING (PART LOAD)

Entering Wet Bulb Temperature	Total Air Volume	Outdoor Air Temperature Entering Outdoor Coil																			
		65°F					75°F					85°F					95°F				
		Total Cool Cap.	Comp. Motor Input	Sensible To Total Ratio (S/T)			Total Cool Cap.	Comp. Motor Input	Sensible To Total Ratio (S/T)			Total Cool Cap.	Comp. Motor Input	Sensible To Total Ratio (S/T)			Total Cool Cap.	Comp. Motor Input	Sensible To Total Ratio (S/T)		
				Dry Bulb					Dry Bulb					Dry Bulb					Dry Bulb		
		cfm	kBtuh	kW	75°F	80°F	85°F	kBtuh	kW	75°F	80°F	85°F	kBtuh	kW	75°F	80°F	85°F	kBtuh	kW	75°F	80°F
63°F	8000	100.4	7.25	.55	.74	.93	83.6	7.96	.47	.71	.96	66.7	8.67	.38	.69	.99	49.8	9.38	.29	.66	1.00
	9500	106.3	7.33	.58	.77	.97	89.3	8.02	.50	.76	.99	72.3	8.71	.42	.74	1.00	55.2	9.40	.34	.72	1.00
	11,000	112.2	7.40	.61	.81	.99	95.0	8.08	.53	.80	1.00	77.8	8.75	.46	.80	1.00	60.6	9.43	.38	.79	1.00
67°F	8000	116.1	7.40	.37	.54	.71	98.8	8.14	.27	.48	.70	81.5	8.87	.17	.43	.69	64.2	9.61	.07	.37	.68
	9500	122.7	7.460	0.38	0.56	0.74	104.2	8.190	0.28	0.51	0.74	85.8	8.910	0.18	0.46	0.74	67.3	9.635	0.08	0.41	0.75
	11,000	129.2	7.52	.40	.58	.77	109.6	8.24	.30	.54	.78	90.1	8.95	.20	.50	.80	70.5	9.66	.09	.46	.82
71°F	8000	131.7	7.55	.19	.34	.49	114.0	8.31	.07	.25	.44	96.3	9.07	-.04	.17	.38	78.6	9.83	-.16	.09	.33
	9500	139.0	7.60	.19	.35	.51	119.1	8.36	.07	.27	.46	99.3	9.11	-.06	.19	.43	79.5	9.86	-.18	.11	.38
	11,000	146.2	7.65	.19	.36	.52	124.2	8.40	.07	.28	.49	102.3	9.14	-.07	.20	.47	80.4	9.89	-.20	.12	.44

25 TON STANDARD EFFICIENCY LCH300S4 WITH HUMIDITROL® OPERATING (FULL LOAD)

Entering Wet Bulb Temperature	Total Air Volume	Outdoor Air Temperature Entering Outdoor Coil																			
		65°F					75°F					85°F					95°F				
		Total Cool Cap.	Comp. Motor Input	Sensible To Total Ratio (S/T)			Total Cool Cap.	Comp. Motor Input	Sensible To Total Ratio (S/T)			Total Cool Cap.	Comp. Motor Input	Sensible To Total Ratio (S/T)			Total Cool Cap.	Comp. Motor Input	Sensible To Total Ratio (S/T)		
				Dry Bulb					Dry Bulb					Dry Bulb					Dry Bulb		
		cfm	kBtuh	kW	75°F	80°F	85°F	kBtuh	kW	75°F	80°F	85°F	kBtuh	kW	75°F	80°F	85°F	kBtuh	kW	75°F	80°F
63°F	8000	260.3	14.9	.66	.80	.95	234.7	16.7	.65	.81	.97	209.1	18.5	.65	.82	.98	183.5	20.3	.65	.82	1.00
	9500	276.4	15.0	.69	.83	.96	248.2	16.8	.70	.84	.97	220.1	18.6	.70	.85	.99	191.9	20.4	.71	.85	1.00
	11,000	279.6	15.1	.73	.87	1.00	253.1	16.9	.75	.87	1.00	226.7	18.7	.76	.88	1.00	200.3	20.5	.78	.89	1.00
67°F	8000	283.9	15.2	.50	.64	.78	257.7	17.0	.48	.63	.79	231.5	18.8	.46	.63	.80	205.3	20.7	.44	.62	.81
	9500	294.1	15.3	.52	.67	.81	266.7	17.1	.51	.66	.82	239.3	18.9	.49	.66	.82	211.9	20.8	.48	.66	.83
	11,000	302.0	15.4	.54	.69	.84	274.2	17.2	.53	.69	.85	246.3	19.1	.53	.69	.86	218.4	20.9	.52	.69	.87
71°F	8000	307.5	15.5	.34	.47	.61	280.7	17.3	.31	.46	.61	253.9	19.2	.27	.44	.61	227.2	21.1	.24	.43	.61
	9500	311.7	15.5	.35	.51	.66	285.1	17.4	.32	.49	.66	258.5	19.3	.28	.47	.66	231.9	21.2	.25	.46	.66
	11,000	324.5	15.6	.35	.51	.67	295.2	17.5	.32	.51	.69	265.9	19.4	.29	.50	.71	236.6	21.3	.26	.50	.73

BLOWER DATA

BLOWER TABLE INCLUDES RESISTANCE FOR BASE UNIT ONLY WITH DRY INDOOR COIL & AIR FILTERS IN PLACE

FOR ALL UNITS ADD:

- 1 - Wet indoor coil air resistance of selected unit.
- 2 - Any factory installed options air resistance (electric heat, economizer, etc.)
- 3 - Any field installed accessories air resistance (electric heat, duct resistance, diffuser, etc.)

Then determine from blower table blower motor output and drive required.

See page 45 for wet coil and option/accessory air resistance data.

See page 45 for factory installed drive kit specifications.

MINIMUM AIR VOLUME REQUIRED FOR USE WITH OPTIONAL ELECTRIC HEAT

LCH156H units require 5200 cfm minimum air with electric heat.

All other units require 6000 cfm minimum air with electric heat.

Air Volume cfm	TOTAL STATIC PRESSURE - Inches Water Gauge (Pa)																									
	0.20		0.40		0.60		0.80		1.00		1.20		1.40		1.60		1.80		2.00		2.20		2.40		2.60	
	RPM	BHP	RPM	BHP	RPM	BHP	RPM	BHP	RPM	BHP	RPM	BHP	RPM	BHP	RPM	BHP	RPM	BHP	RPM	BHP	RPM	BHP	RPM	BHP	RPM	BHP
2750	385	0.30	505	0.50	600	0.70	680	0.90	755	1.10	820	1.30	885	1.70	950	2.10	1005	2.55	1100	3.00	1110	3.30	1160	3.85	1205	4.15
3000	395	0.35	515	0.55	610	0.75	685	1.00	760	1.20	825	1.45	890	1.85	955	2.25	1050	2.70	1140	3.15	1150	3.45	1200	3.75	1210	4.45
3250	405	0.40	520	0.60	615	0.85	695	1.10	765	1.30	830	1.60	895	2.00	960	2.40	1055	2.85	1140	3.25	1150	3.55	1200	3.85	1210	4.45
3500	415	0.45	530	0.70	620	0.95	700	1.20	775	1.45	840	1.70	900	2.10	965	2.50	1060	2.90	1140	3.30	1150	3.60	1200	3.90	1210	4.70
3750	425	0.50	540	0.75	630	1.05	710	1.30	780	1.60	845	1.85	905	2.25	970	2.65	1065	3.05	1140	3.40	1150	3.70	1200	4.00	1210	4.70
4000	435	0.55	545	0.85	635	1.10	715	1.40	785	1.70	850	2.00	910	2.35	975	2.75	1070	3.15	1140	3.50	1150	3.80	1200	4.10	1210	4.45
4250	445	0.60	555	0.90	645	1.25	725	1.55	795	1.85	855	2.15	915	2.45	980	2.85	1075	3.25	1140	3.60	1150	3.90	1200	4.15	1210	4.45
4500	455	0.70	565	1.00	655	1.35	730	1.65	800	2.00	865	2.35	925	2.65	990	3.05	1085	3.45	1140	3.70	1150	4.00	1200	4.30	1210	4.70
4750	470	0.75	575	1.10	660	1.45	740	1.80	810	2.15	870	2.50	930	2.85	995	3.25	1090	3.65	1140	3.90	1150	4.20	1200	4.50	1210	5.00
5000	480	0.85	585	1.25	670	1.60	750	1.95	815	2.30	880	2.70	940	3.05	1000	3.40	1100	3.80	1140	4.00	1150	4.30	1200	4.60	1210	5.30
5250	495	0.95	595	1.35	680	1.70	755	2.10	825	2.50	890	2.90	950	3.25	1010	3.65	1110	4.00	1140	4.20	1150	4.50	1200	4.80	1210	5.60
5500	505	1.05	605	1.45	690	1.85	765	2.25	835	2.65	895	3.05	955	3.40	1015	3.80	1115	4.15	1140	4.30	1150	4.60	1200	4.90	1210	5.90
5750	520	1.15	615	1.60	700	2.00	775	2.45	840	2.85	905	3.25	965	3.60	1025	4.00	1120	4.30	1140	4.40	1150	4.70	1200	5.00	1210	6.25
6000	530	1.30	630	1.75	710	2.15	785	2.60	850	3.05	910	3.45	970	3.80	1030	4.20	1130	4.50	1140	4.60	1150	4.90	1200	5.20	1210	6.55
6250	545	1.40	640	1.90	720	2.35	795	2.80	860	3.25	920	3.70	975	4.15	1030	4.50	1130	4.80	1140	4.90	1150	5.20	1200	5.50	1210	6.90
6500	560	1.55	650	2.05	730	2.50	805	3.00	870	3.45	930	3.95	985	4.40	1040	4.85	1140	5.15	1140	5.25	1150	5.50	1200	5.80	1210	7.25
6750	570	1.70	665	2.20	745	2.70	815	3.20	880	3.70	940	4.20	995	4.65	1045	5.10	1140	5.40	1140	5.50	1150	5.80	1200	6.10	1210	7.60
7000	585	1.85	675	2.35	755	2.90	825	3.40	890	3.95	950	4.45	1005	4.90	1055	5.40	1140	5.65	1140	5.75	1150	6.00	1200	6.35	1210	8.00
7250	600	2.00	690	2.60	765	3.10	835	3.65	900	4.15	955	4.65	1010	5.25	1065	5.75	1150	6.00	1140	6.10	1150	6.35	1200	6.60	1210	8.35
7500	615	2.20	700	2.75	775	3.30	845	3.85	910	4.45	965	4.95	1020	5.50	1075	6.05	1150	6.30	1140	6.40	1150	6.65	1200	6.85	1210	8.75
7750	630	2.40	715	3.00	790	3.55	855	4.10	920	4.70	975	5.25	1030	5.80	1080	6.35	1150	6.60	1140	6.70	1150	6.95	1200	7.10	1210	9.15
8000	645	2.55	725	3.20	800	3.80	865	4.35	930	4.95	985	5.50	1040	6.10	1090	6.70	1140	6.90	1140	7.00	1150	7.25	1200	7.35	1210	9.60
8250	655	2.80	740	3.40	810	4.00	880	4.65	940	5.25	995	5.85	1050	6.45	1100	7.05	1150	7.15	1140	7.25	1150	7.50	1200	7.65	1210	10.05
8500	670	3.00	750	3.65	825	4.30	890	4.90	950	5.55	1005	6.15	1060	6.80	1110	7.40	1150	7.40	1140	7.50	1150	7.85	1200	7.95	1210	10.45
8750	685	3.25	765	3.90	835	4.55	900	5.20	960	5.85	1015	6.45	1070	7.15	1120	7.75	1165	7.65	1140	7.75	1150	8.10	1200	8.25	1210	10.90
9000	700	3.50	780	4.20	850	4.85	910	5.50	970	6.15	1025	6.80	1080	7.50	1130	8.15	1175	7.85	1140	7.95	1150	8.30	1200	8.50	1210	11.40
9250	715	3.75	790	4.45	860	5.15	925	5.85	985	6.55	1040	7.20	1090	7.85	1140	8.55	1185	8.10	1140	8.20	1150	8.55	1200	8.75	1210	11.40
9500	730	4.00	805	4.75	875	5.45	935	6.15	995	6.90	1050	7.60	1100	8.25	1150	8.95	1195	8.30	1140	8.40	1150	8.85	1200	9.00	1210	11.40
9750	745	4.30	820	5.05	885	5.75	950	6.55	1005	7.20	1060	7.95	1110	8.65	1160	9.40	1205	8.60	1140	8.60	1150	9.15	1200	9.25	1210	11.40
10,000	760	4.60	835	5.40	900	6.15	960	6.85	1015	7.60	1070	8.35	1120	9.05	1170	9.80	1215	9.00	1140	9.10	1150	9.65	1200	9.80	1210	11.40
10,250	775	4.90	845	5.65	910	6.45	970	7.20	1030	8.00	1080	8.75	1135	9.55	1180	10.25	1225	9.30	1140	9.30	1150	9.95	1200	10.00	1210	11.40
10,500	790	5.20	860	6.00	925	6.85	985	7.65	1040	8.40	1095	9.20	1145	10.00	1190	10.70	1235	9.60	1140	9.60	1150	10.30	1200	10.30	1210	11.40
10,750	805	5.55	875	6.40	940	7.25	1000	8.05	1055	8.85	1105	9.65	1155	10.45	1200	11.20	1245	9.90	1140	10.00	1150	10.60	1200	10.60	1210	11.40
11,000	820	5.90	890	6.80	950	7.60	1010	8.45	1065	9.30	1115	10.05	1165	10.90	1210	11.65	1255	10.20	1140	10.30	1150	10.90	1200	10.90	1210	11.40

BLOWER DATA

FACTORY INSTALLED BELT DRIVE KIT SPECIFICATIONS

Motor Efficiency	Nominal hp	Maximum hp	Drive Kit Number	RPM Range
Standard or High	2	2.30	1	535 - 725
Standard or High	2	2.30	2	710 - 965
Standard	3	3.45	1	535 - 725
Standard	3	3.45	2	710 - 965
High	3	3.45	3	685 - 856
High	3	3.45	4	850 - 1045
Standard	5	5.75	3	685 - 856
Standard	5	5.75	4	850 - 1045
Standard	5	5.75	5	945 - 1185
Standard	7.5	8.63	6	850 - 1045
Standard	7.5	8.63	7	945 - 1185
Standard	7.5	8.63	8	1045 - 1285
Standard	10	11.50	7	945 - 1185
Standard	10	11.50	10	1045 - 1285
Standard	10	11.50	11	1135 - 1365

NOTE - Using total air volume and system static pressure requirements determine from blower performance tables rpm and motor output required. Maximum usable output of motors furnished are shown. In Canada, nominal motor output is also maximum usable motor output. If motors of comparable output are used, be sure to keep within the service factor limitations outlined on the motor nameplate.

NOTE - Units equipped with MSAV® Multi-Stage Air Volume option are limited to a motor service factor of 1.0.

FACTORY INSTALLED OPTIONS/FIELD INSTALLED ACCESSORY AIR RESISTANCE - in w.g.

Air Volume cfm	Wet Indoor Coil		Reheat Coil	Electric Heat	Economizer	Filters			Horizontal Roof Curb	
	156H, 180H	210H, 240H 300S				MERV 8	MERV 13	MERV 16	156H thru 240H	300S
2750	.01	.02	.01	---	---	.01	.03	.06	.03	---
3000	.01	.02	.01	---	---	.01	.03	.06	.04	---
3250	.01	.03	.01	---	---	.01	.04	.07	.04	.01
3500	.01	.03	.02	---	---	.01	.04	.08	.05	.01
3750	.01	.03	.02	---	---	.01	.04	.08	.05	.01
4000	.02	.04	.02	---	---	.01	.04	.09	.06	.02
4250	.02	.04	.02	---	---	.01	.05	.10	.07	.02
4500	.02	.05	.02	---	---	.01	.05	.10	.07	.02
4750	.02	.05	.02	---	---	.02	.05	.11	.08	.03
5000	.02	.05	.02	---	---	.02	.06	.12	.08	.03
5250	.02	.06	.03	---	---	.02	.06	.12	.09	.04
5500	.02	.07	.03	---	---	.02	.06	.13	.10	.04
5750	.03	.07	.03	---	---	.02	.07	.14	.11	.05
6000	.03	.08	.03	.01	---	.03	.07	.14	.11	.06
6250	.03	.08	.03	.01	.01	.03	.07	.15	.12	.07
6500	.03	.09	.04	.01	.02	.03	.08	.16	.13	.08
6750	.04	.10	.04	.01	.03	.03	.08	.17	.14	.08
7000	.04	.10	.04	.01	.04	.04	.08	.17	.15	.09
7250	.04	.11	.04	.01	.05	.04	.09	.18	.16	.10
7500	.05	.12	.05	.01	.06	.04	.09	.19	.17	.11
8000	.05	.13	.05	.02	.09	.05	.10	.21	.19	.13
8500	.06	.15	.05	.02	.11	.05	.10	.22	.21	.15
9000	.07	.16	.06	.04	.14	.06	.11	.24	.24	.17
9500	.08	.18	.07	.05	.16	.07	.12	.25	.26	.19
10,000	.08	.20	.07	.06	.19	.07	.12	.27	.29	.21
10,500	.09	.22	.08	.09	.22	.08	.13	.29	.31	.24
11,000	.11	.24	.08	.11	.25	.09	.14	.30	.34	.27

BLOWER DATA

POWER EXHAUST FAN PERFORMANCE

Return Air System Static Pressure	Air Volume Exhausted
in. w.g.	cfm
0.00	8630
0.05	8210
0.10	7725
0.15	7110
0.20	6470
0.25	5790
0.30	5060
0.35	4300
0.40	3510
0.45	2690
0.50	1840

CEILING DIFFUSER AIR RESISTANCE - in. w.g.

Air Volume cfm	Step-Down Diffuser						Flush Diffuser	
	RTD11-185S			RTD11-275S			FD11-185S	FD11-275S
	2 Ends Open	1 Side/2 Ends Open	All Ends & Sides Open	2 Ends Open	1 Side/2 Ends Open	All Ends & Sides Open		
5000	.51	.44	.39	---	---	---	.27	---
5200	.56	.48	.42	---	---	---	.30	---
5400	.61	.52	.45	---	---	---	.33	---
5600	.66	.56	.48	---	---	---	.36	---
5800	.71	.59	.51	---	---	---	.39	---
6000	.76	.63	.55	.36	.31	.27	.42	.29
6200	.80	.68	.59	---	---	---	.46	---
6400	.86	.72	.63	---	---	---	.50	---
6500	---	---	---	.42	.36	.31	---	.34
6600	.92	.77	.67	---	---	---	.54	---
6800	.99	.83	.72	---	---	---	.58	---
7000	1.03	.87	.76	.49	.41	.36	.62	.40
7200	1.09	.92	.80	---	---	---	.66	---
7400	1.15	.97	.84	---	---	---	.70	---
7500	---	---	---	.51	.46	.41	---	.45
7600	1.20	1.02	.88	---	---	---	.74	---
8000	---	---	---	.59	.49	.43	---	.50
8500	---	---	---	.69	.58	.50	---	.57
9000	---	---	---	.79	.67	.58	---	.66
9500	---	---	---	.89	.75	.65	---	.74
10,000	---	---	---	1.00	.84	.73	---	.81
10,500	---	---	---	1.10	.92	.80	---	.89
11,000	---	---	---	1.21	1.01	.88	---	.96

CEILING DIFFUSER AIR THROW DATA - ft.

Model No.	Air Volume cfm	¹ Effective Throw Range - ft.		Model No.	Air Volume cfm	¹ Effective Throw Range - ft.	
		RTD11-185S Step-Down	FD11-185S Flush			RTD11-275S Step-Down	FD11-275S Flush
156 180	5600	39 - 49	28 - 37	210 240 300	7200	33 - 38	26 - 35
	5800	42 - 51	29 - 38		7400	35 - 40	28 - 37
	6000	44 - 54	40 - 50		7600	36 - 41	29 - 38
	6200	45 - 55	42 - 51		7800	38 - 43	40 - 50
	6400	46 - 55	43 - 52		8000	39 - 44	42 - 51
	6600	47 - 56	45 - 56		8200	41 - 46	43 - 52
					8400	43 - 49	44 - 54
					8600	44 - 50	46 - 57
					8800	47 - 55	48 - 59

¹ Throw is the horizontal or vertical distance an airstream travels on leaving the outlet or diffuser before the maximum velocity is reduced to 50 ft. per minute. Four sides open.

ELECTRICAL/ELECTRIC HEAT DATA

13 TON

13 TON HIGH EFFICIENCY

LCH156H4

¹ Voltage - 60Hz		208/230V - 3 Ph			460V - 3 Ph			575V - 3 Ph		
Compressor 1	Rated Load Amps	14.5			6.3			6.0		
	Locked Rotor Amps	98			55			41		
Compressor 2	Rated Load Amps	14.5			6.3			6		
	Locked Rotor Amps	98			55			41		
Compressor 3	Rated Load Amps	14.5			6.3			6		
	Locked Rotor Amps	98			55			41		
Outdoor Fan Motors (3)	Full Load Amps (total)	2.4 (7.2)			1.3 (3.9)			1 (3)		
Power Exhaust (2) 0.33 HP	Full Load Amps (total)	2.4 (4.8)			1.3 (2.6)			1 (2)		
Service Outlet 115V GFI (amps)		15			15			20		
Indoor Blower Motor	Horsepower	2	3	5	2	3	5	2	3	5
	Full Load Amps	7.5	10.6	16.7	3.4	4.8	7.6	2.7	3.9	6.1
² Maximum Overcurrent Protection	Unit Only	70	70	80	30	35	35	30	30	30
	With (2) 0.33 HP Power Exhaust	80	80	90	35	35	40	30	30	35
³ Minimum Circuit Ampacity	Unit Only	62	65	72	28	30	33	26	27	29
	With (2) 0.33 HP Power Exhaust	67	70	77	31	32	35	28	29	31

ELECTRIC HEAT DATA

		Electric Heat Voltage	208V	240V	208V	240V	208V	240V	480V	480V	480V	600V	600V	600V
² Maximum Overcurrent Protection	Unit+ Electric Heat	15 kW	70	70	70	70	80	80	30	35	35	30	30	30
		30 kW	⁴ 90	100	⁴ 100	110	⁴ 100	125	50	60	60	40	45	45
		45 kW	150	150	150	150	⁴ 150	175	80	80	80	60	60	70
		60 kW	⁴ 150	175	⁴ 150	175	⁴ 150	175	80	80	90	70	70	70
³ Minimum Circuit Ampacity	Unit+ Electric Heat	15 kW	62	62	65	65	72	72	28	30	33	26	27	29
		30 kW	88	100	92	104	100	112	50	52	55	40	41	44
		45 kW	127	145	131	149	139	157	72	74	78	58	60	62
		60 kW	135	154	139	158	146	166	77	79	82	62	63	66
² Maximum Overcurrent Protection	Unit+ Electric Heat and (2) 0.33 HP Power Exhaust	15 kW	80	80	80	80	90	90	35	35	40	30	30	35
		30 kW	⁴ 100	110	⁴ 100	110	⁴ 110	125	60	60	60	45	45	50
		45 kW	⁴ 150	175	⁴ 150	175	⁴ 150	175	80	80	90	70	70	70
		60 kW	⁴ 150	175	⁴ 150	175	175	175	80	90	90	70	70	70
³ Minimum Circuit Ampacity	Unit+ Electric Heat and (2) 0.33 HP Power Exhaust	15 kW	67	67	70	70	77	77	31	32	36	28	29	31
		30 kW	94	106	98	110	106	118	53	55	58	42	44	47
		45 kW	133	151	137	155	145	163	76	77	81	61	62	65
		60 kW	141	160	145	164	152	172	80	82	85	64	66	68

NOTE - All units have a minimum Short Circuit Current Rating (SCCR) of 5000 amps.

¹ Extremes of operating range are plus and minus 10% of line voltage.

² HACR type breaker or fuse.

³ Refer to National or Canadian Electrical Code manual to determine wire, fuse and disconnect size requirements.

⁴ Factory installed circuit breaker not available.

ELECTRICAL/ELECTRIC HEAT DATA

15 TON

15 TON HIGH EFFICIENCY

LCH180H4

¹ Voltage - 60Hz		208/230V - 3 Ph			460V - 3 Ph			575V - 3 Ph		
Compressor 1	Rated Load Amps	13.2			6.3			4.9		
	Locked Rotor Amps	93			60			41		
Compressor 2	Rated Load Amps	13.2			6.3			4.9		
	Locked Rotor Amps	93			60			41		
Compressor 3	Rated Load Amps	13.2			6.3			4.9		
	Locked Rotor Amps	93			60			41		
Outdoor Fan Motors (8)	Full Load Amps (total)	2.4 (9.6)			1.3 (5.2)			1 (4)		
Power Exhaust (2) 0.33 HP	Full Load Amps (total)	2.4 (4.8)			1.3 (2.6)			1 (2)		
Service Outlet 115V GFI (amps)		15			15			20		
Indoor Blower Motor	Horsepower	3	5	7.5	3	5	7.5	3	5	7.5
	Full Load Amps	10.6	16.7	24.2	4.8	7.6	11	3.9	6.1	9
² Maximum Overcurrent Protection	Unit Only	70	80	100	35	40	45	25	30	35
	With (2) 0.33 HP Power Exhaust	80	90	100	35	40	50	30	30	40
³ Minimum Circuit Ampacity	Unit Only	64	71	80	31	34	38	24	27	30
	With (2) 0.33 HP Power Exhaust	68	75	85	34	37	41	26	29	32

ELECTRIC HEAT DATA

Electric Heat Voltage		208V	240V	208V	240V	208V	240V	480V	480V	480V	600V	600V	600V	
² Maximum Overcurrent Protection	Unit+ Electric Heat	15 kW	70	70	80	80	100	100	35	40	45	25	30	35
		30 kW	⁴ 100	110	⁴ 100	125	⁴ 110	125	60	60	60	45	45	50
		45 kW	150	150	⁴ 150	175	⁴ 150	175	80	80	90	60	70	70
		60 kW	⁴ 150	175	⁴ 150	175	175	175	80	90	90	70	70	70
³ Minimum Circuit Ampacity	Unit+ Electric Heat	15 kW	64	64	71	71	80	80	31	34	38	24	27	30
		30 kW	92	104	100	112	109	121	52	55	59	41	44	48
		45 kW	131	149	139	157	148	166	74	78	82	60	62	66
		60 kW	139	158	146	166	156	175	79	82	86	63	66	69
² Maximum Overcurrent Protection	Unit+ Electric Heat and (2) 0.33 HP Power Exhaust	15 kW	80	80	90	90	100	100	35	40	50	30	30	40
		30 kW	⁴ 100	110	⁴ 110	125	⁴ 125	150	60	60	70	45	50	50
		45 kW	⁴ 150	175	⁴ 150	175	175	175	80	90	90	70	70	70
		60 kW	⁴ 150	175	175	175	⁴ 175	200	90	90	90	70	70	80
³ Minimum Circuit Ampacity	Unit+ Electric Heat and (2) 0.33 HP Power Exhaust	15 kW	68	68	75	75	85	85	34	37	41	26	29	32
		30 kW	98	110	106	118	115	127	55	58	63	44	47	50
		45 kW	137	155	145	163	154	172	77	81	85	62	65	68
		60 kW	145	164	152	172	162	181	82	85	90	66	68	72

NOTE - All units have a minimum Short Circuit Current Rating (SCCR) of 5000 amps.

¹ Extremes of operating range are plus and minus 10% of line voltage.

² HACR type breaker or fuse.

³ Refer to National or Canadian Electrical Code manual to determine wire, fuse and disconnect size requirements.

⁴ Factory installed circuit breaker not available.

ELECTRICAL/ELECTRIC HEAT DATA

17.5 TON

17.5 TON HIGH EFFICIENCY

LCH210H4B/M

¹ Voltage - 60Hz		208/230V - 3 Ph			460V - 3 Ph			575V - 3 Ph		
Compressor 1	Rated Load Amps	15.6			7.8			5.8		
	Locked Rotor Amps	110			52			38.9		
Compressor 2	Rated Load Amps	15.6			7.8			5.8		
	Locked Rotor Amps	110			52			38.9		
Compressor 3	Rated Load Amps	19.6			8.2			6.6		
	Locked Rotor Amps	136			66.1			55.3		
Outdoor Fan Motors (3)	Full Load Amps (total)	2.4 (14.4)			1.3 (7.8)			1 (6)		
Power Exhaust (2) 0.33 HP	Full Load Amps (total)	2.4 (4.8)			1.3 (2.6)			1 (2)		
Service Outlet 115V GFI (amps)		15			15			15		
Indoor Blower Motor	Horsepower	3	5	7.5	3	5	7.5	3	5	7.5
	Full Load Amps	10.6	16.7	24.2	4.8	7.6	11	3.9	6.1	9
² Maximum Overcurrent Protection	Unit Only	100	100	110	45	45	50	35	35	40
	With (2) 0.33 HP Power Exhaust	100	110	110	45	50	50	35	40	45
³ Minimum Circuit Ampacity	Unit Only	81	87	96	39	42	46	30	32	36
	With (2) 0.33 HP Power Exhaust	86	92	101	42	44	48	32	34	38

ELECTRIC HEAT DATA

		Electric Heat Voltage	208V	240V	208V	240V	208V	240V	480V	480V	480V	600V	600V	600V
² Maximum Overcurrent Protection	Unit+ Electric Heat	15 kW	100	100	100	100	110	110	45	45	50	35	35	40
		30 kW	⁴ 100	110	⁴ 100	125	⁴ 110	125	60	60	60	45	45	50
		45 kW	150	150	⁴ 150	175	⁴ 150	175	80	80	90	60	70	70
		60 kW	⁴ 150	175	⁴ 150	175	175	175	80	90	90	70	70	70
		90 kW	⁴ 225	250	⁴ 225	250	⁴ 225	250	125	125	125	100	100	100
³ Minimum Circuit Ampacity	Unit+ Electric Heat	15 kW	81	81	87	87	96	96	39	42	46	30	32	36
		30 kW	92	104	100	112	109	121	52	55	59	41	44	48
		45 kW	131	149	139	157	148	166	74	78	82	60	62	66
		60 kW	139	158	146	166	156	175	79	82	86	63	66	69
		90 kW	201	230	209	238	218	247	115	118	123	92	95	98
² Maximum Overcurrent Protection	Unit+ Electric Heat and (2) 0.33 HP Power Exhaust	15 kW	100	100	110	110	110	110	45	50	50	35	40	45
		30 kW	⁴ 100	110	⁴ 110	125	⁴ 125	150	60	60	70	45	50	50
		45 kW	⁴ 150	175	⁴ 150	175	175	175	80	90	90	70	70	70
		60 kW	⁴ 150	175	175	175	⁴ 175	200	90	90	90	70	70	80
		90 kW	⁴ 225	250	⁴ 225	250	⁴ 225	⁴ 300	125	125	150	100	100	110
³ Minimum Circuit Ampacity	Unit+ Electric Heat and (2) 0.33 HP Power Exhaust	15 kW	86	86	92	92	101	101	42	44	48	32	34	38
		30 kW	98	110	106	118	115	127	55	58	63	44	47	50
		45 kW	137	155	145	163	154	172	77	81	85	62	65	68
		60 kW	145	164	152	172	162	181	82	85	90	66	68	72
		90 kW	207	236	215	244	224	253	118	122	126	94	97	101

NOTE - All units have a minimum Short Circuit Current Rating (SCCR) of 5000 amps.

¹ Extremes of operating range are plus and minus 10% of line voltage.

² HACR type breaker or fuse.

³ Refer to National or Canadian Electrical Code manual to determine wire, fuse and disconnect size requirements.

⁴ Factory installed circuit breaker not available.

ELECTRICAL/ELECTRIC HEAT DATA

20 TON

20 TON HIGH EFFICIENCY

LCH240H4

¹ Voltage - 60Hz		208/230V - 3 Ph			460V - 3 Ph			575V - 3 Ph		
Compressor 1	Rated Load Amps	13.2			6.3			4.9		
	Locked Rotor Amps	93			60			41		
Compressor 2	Rated Load Amps	13.2			6.3			4.9		
	Locked Rotor Amps	93			60			41		
Compressor 3	Rated Load Amps	13.2			6.3			4.9		
	Locked Rotor Amps	93			60			41		
Compressor 4	Rated Load Amps	13.2			6.3			4.9		
	Locked Rotor Amps	93			60			41		
Outdoor Fan Motors (6)	Full Load Amps (total)	2.4 (14.4)			1.3 (7.8)			1 (6)		
Power Exhaust (2) 0.33 HP	Full Load Amps (total)	2.4 (4.8)			1.3 (2.6)			1 (2)		
Service Outlet 115V GFI (amps)		15			15			20		
Indoor Blower Motor	Horsepower	5	7.5	10	5	7.5	10	5	7.5	10
	Full Load Amps	16.7	24.2	30.8	7.6	11	14	6.1	9	11
² Maximum Overcurrent Protection	Unit Only	100	110	125	50	50	60	35	45	50
	With (2) 0.33 HP Power Exhaust	100	125	125	50	60	60	40	45	50
³ Minimum Circuit Ampacity	Unit Only	89	98	106	43	47	51	34	37	40
	With (2) 0.33 HP Power Exhaust	93	103	111	46	50	54	36	39	42

ELECTRIC HEAT DATA

		Electric Heat Voltage	208V	240V	208V	240V	208V	240V	480V	480V	480V	600V	600V	600V
² Maximum Overcurrent Protection	Unit+ Electric Heat	15 kW	100	100	110	110	125	125	50	50	60	35	45	50
		30 kW	⁴ 100	125	⁴ 110	125	⁴ 125	150	60	60	70	45	50	50
		45 kW	⁴ 150	175	⁴ 150	175	175	175	80	90	90	70	70	70
		60 kW	⁴ 150	175	175	175	⁴ 175	200	90	90	90	70	70	80
		90 kW	⁴ 225	250	⁴ 225	250	⁴ 250	⁴ 300	125	125	150	100	100	110
³ Minimum Circuit Ampacity	Unit+ Electric Heat	15 kW	89	89	98	98	106	106	43	47	51	34	37	40
		30 kW	100	112	109	121	117	129	55	59	63	44	48	50
		45 kW	139	157	148	166	156	174	78	82	86	62	66	68
		60 kW	146	166	156	175	164	183	82	86	90	66	69	72
		90 kW	209	238	218	247	227	256	118	123	126	95	98	101
² Maximum Overcurrent Protection	Unit+ Electric Heat and (2) 0.33 HP Power Exhaust	15 kW	100	100	125	125	125	125	50	60	60	40	45	50
		30 kW	⁴ 110	125	⁴ 125	150	⁴ 125	150	60	70	70	50	50	60
		45 kW	⁴ 150	175	175	175	⁴ 175	200	90	90	90	70	70	80
		60 kW	175	175	⁴ 175	200	⁴ 175	200	90	90	100	70	80	80
		90 kW	⁴ 225	250	⁴ 225	⁴ 300	⁴ 250	⁴ 300	125	150	150	100	110	110
³ Minimum Circuit Ampacity	Unit+ Electric Heat and (2) 0.33 HP Power Exhaust	15 kW	93	93	103	103	111	111	46	50	54	36	39	42
		30 kW	106	118	115	127	123	135	58	63	66	47	50	53
		45 kW	145	163	154	172	162	180	81	85	89	65	68	71
		60 kW	152	172	162	181	170	189	85	90	93	68	72	74
		90 kW	215	244	224	253	233	262	122	126	130	97	101	103

NOTE - All units have a minimum Short Circuit Current Rating (SCCR) of 5000 amps.

¹ Extremes of operating range are plus and minus 10% of line voltage.

² HACR type breaker or fuse.

³ Refer to National or Canadian Electrical Code manual to determine wire, fuse and disconnect size requirements.

⁴ Factory installed circuit breaker not available.

ELECTRICAL/ELECTRIC HEAT DATA

25 TON

25 TON STANDARD EFFICIENCY

LCH300S4B/M

¹ Voltage - 60Hz		208/230V - 3 Ph			460V - 3 Ph			575V - 3 Ph		
Compressor 1	Rated Load Amps	19.6			8.2			6.6		
	Locked Rotor Amps	136			66.1			55.3		
Compressor 2	Rated Load Amps	19.6			8.2			6.6		
	Locked Rotor Amps	136			66.1			55.3		
Compressor 3	Rated Load Amps	22.4			10.6			7.7		
	Locked Rotor Amps	149			75			54		
Compressor 4	Rated Load Amps	22.4			10.6			7.7		
	Locked Rotor Amps	149			75			54		
Outdoor Fan Motors (6)	Full Load Amps (total)	2.4 (14.4)			1.3 (7.8)			1 (6)		
Power Exhaust (2) 0.33 HP	Full Load Amps (total)	2.4 (4.8)			1.3 (2.6)			1 (2)		
Service Outlet 115V GFI (amps)		15			15			20		
Indoor Blower Motor	Horsepower	5	7.5	10	5	7.5	10	5	7.5	10
	Full Load Amps	16.7	24.2	30.8	7.6	11	14	6.1	9	11
² Maximum Overcurrent Protection	Unit Only	125	150	150	60	70	70	50	50	50
	With (2) 0.33 HP Power Exhaust	150	150	150	60	70	70	50	50	60
³ Minimum Circuit Ampacity	Unit Only	121	129	137	56	60	63	45	46	49
	With (2) 0.33 HP Power Exhaust	126	134	142	59	62	66	45	48	51

ELECTRIC HEAT DATA

		Electric Heat Voltage	208V	240V	208V	240V	208V	240V	480V	480V	480V	600V	600V	600V
² Maximum Overcurrent Protection	Unit+ Electric Heat	15 kW	125	125	150	150	150	150	60	70	70	50	50	50
		30 kW	125	125	150	150	150	150	60	70	70	50	50	50
		45 kW	⁴ 150	175	⁴ 150	175	175	175	80	90	90	70	70	70
		60 kW	⁴ 150	175	175	175	⁴ 175	200	90	90	90	70	70	80
		90 kW	⁴ 225	250	⁴ 225	250	⁴ 250	⁴ 300	125	125	150	100	100	110
³ Minimum Circuit Ampacity	Unit+ Electric Heat	15 kW	121	121	129	129	137	137	56	60	63	45	46	49
		30 kW	121	121	129	129	137	137	56	60	63	45	46	49
		45 kW	139	157	148	166	156	174	78	82	86	62	66	68
		60 kW	146	166	156	175	164	183	82	86	90	66	69	72
		90 kW	209	238	218	247	227	256	118	123	126	95	98	101
² Maximum Overcurrent Protection	Unit+ Electric Heat and (2) 0.33 HP Power Exhaust	15 kW	150	150	150	150	150	150	60	70	70	50	50	60
		30 kW	150	150	150	150	150	150	60	70	70	50	50	60
		45 kW	⁴ 150	175	175	175	⁴ 175	200	90	90	90	70	70	80
		60 kW	175	175	⁴ 175	200	⁴ 175	200	90	90	100	70	80	80
		90 kW	⁴ 225	250	⁴ 225	⁴ 300	⁴ 250	⁴ 300	125	150	150	100	110	110
³ Minimum Circuit Ampacity	Unit+ Electric Heat and (2) 0.33 HP Power Exhaust	15 kW	126	126	134	134	142	142	59	62	66	45	48	51
		30 kW	126	126	134	134	142	142	59	62	66	45	48	51
		45 kW	145	163	154	172	162	180	81	85	89	65	68	71
		60 kW	152	172	162	181	170	189	85	90	93	68	72	74
		90 kW	215	244	224	253	233	262	122	126	130	97	101	103

NOTE - All units have a minimum Short Circuit Current Rating (SCCR) of 5000 amps.

¹ Extremes of operating range are plus and minus 10% of line voltage.

² HACR type breaker or fuse.

³ Refer to National or Canadian Electrical Code manual to determine wire, fuse and disconnect size requirements.

⁴ Factory installed circuit breaker not available.

ELECTRICAL ACCESSORIES - DISCONNECTS

13 TON | LCH156H4

Motor Horsepower	2		3		5		2	3	5	2	3	5
	208V	240V	208V	240V	208V	240V	480V	480V	480V	600V	600V	600V
Unit Only	54W85	54W85	54W85	54W85	54W85	54W85	54W85	54W85	54W85	54W85	54W85	54W85
+ Power Exhaust	54W85	54W85	54W85	54W85	54W86	54W86	54W85	54W85	54W85	54W85	54W85	54W85
+ Electric Heat 15 kW	54W85	54W85	54W85	54W85	54W85	54W85	54W85	54W85	54W85	54W85	54W85	54W85
+ Electric Heat 30 kW	54W86	54W86	54W86	54W86	54W86	54W86	54W85	54W85	54W85	54W85	54W85	54W85
+ Electric Heat 45 kW	54W86	54W86	54W86	54W86	54W86	54W86	54W85	54W85	54W85	54W85	54W85	54W85
+ Electric Heat 60 kW	54W87	54W87	54W87	54W87	54W87	54W87	54W86	54W86	54W86	54W85	54W85	54W85
+ Power Exhaust + Elec. Heat 15 kW	54W85	54W85	54W85	54W85	54W85	54W85	54W85	54W85	54W85	54W85	54W85	54W85
+ Power Exhaust + Elec. Heat 30 kW	54W86	54W86	54W86	54W86	54W86	54W86	54W85	54W85	54W85	54W85	54W85	54W85
+ Power Exhaust + Elec. Heat 45 kW	54W86	54W86	54W86	54W86	54W86	54W86	54W85	54W85	54W85	54W85	54W85	54W85
+ Power Exhaust + Elec. Heat 60 kW	54W87	54W87	54W87	54W87	54W87	54W87	54W86	54W86	54W86	54W85	54W85	54W85

15 TON | LCH180H4

Motor Horsepower	3		5		7.5		3	5	7.5	3	5	7.5
	208V	240V	208V	240V	208V	240V	480V	480V	480V	600V	600V	600V
Unit Only	54W85	54W85	54W85	54W85	54W86	54W86	54W85	54W85	54W85	54W85	54W85	54W85
+ Power Exhaust	54W85	54W85	54W86	54W86	54W86	54W86	54W85	54W85	54W85	54W85	54W85	54W85
+ Electric Heat 15 kW	54W85	54W85	54W85	54W85	54W85	54W85	54W85	54W85	54W85	54W85	54W85	54W85
+ Electric Heat 30 kW	54W86	54W86	54W86	54W86	54W86	54W86	54W85	54W85	54W85	54W85	54W85	54W85
+ Electric Heat 45 kW	54W86	54W86	54W86	54W86	54W86	54W87	54W85	54W85	54W85	54W85	54W85	54W85
+ Electric Heat 60 kW	54W87	54W87	54W87	54W87	54W87	54W87	54W86	54W86	54W86	54W85	54W85	54W85
+ Power Exhaust + Elec. Heat 15 kW	54W85	54W85	54W85	54W85	54W85	54W85	54W85	54W85	54W85	54W85	54W85	54W85
+ Power Exhaust + Elec. Heat 30 kW	54W86	54W86	54W86	54W86	54W86	54W86	54W85	54W85	54W85	54W85	54W85	54W85
+ Power Exhaust + Elec. Heat 45 kW	54W86	54W86	54W86	54W86	54W86	54W87	54W85	54W85	54W85	54W85	54W85	54W85
+ Power Exhaust + Elec. Heat 60 kW	54W87	54W87	54W87	54W87	54W87	54W87	54W86	54W86	54W86	54W85	54W85	54W85

17.5 TON | LCH210H4

Motor Horsepower	3		5		7.5		3	5	7.5	3	5	7.5
	208V	240V	208V	240V	208V	240V	480V	480V	480V	600V	600V	600V
Unit Only	54W86	54W86	54W86	54W86	54W86	54W86	54W85	54W85	54W85	54W85	54W85	54W85
+ Power Exhaust	54W86	54W86	54W86	54W86	54W86	54W86	54W85	54W85	54W85	54W85	54W85	54W85
+ Electric Heat 15 kW	54W85	54W85	54W85	54W85	54W85	54W85	54W85	54W85	54W85	54W85	54W85	54W85
+ Electric Heat 30 kW	54W86	54W86	54W86	54W86	54W86	54W86	54W85	54W85	54W85	54W85	54W85	54W85
+ Electric Heat 45 kW	54W86	54W86	54W86	54W86	54W86	54W87	54W85	54W85	54W85	54W85	54W85	54W85
+ Electric Heat 60 kW	54W87	54W87	54W87	54W87	54W87	54W87	54W86	54W86	54W86	54W85	54W85	54W85
+ Electric Heat 90 kW	¹ N/A	¹ N/A	¹ N/A	¹ N/A	¹ N/A	¹ N/A	54W86	54W86	54W86	54W86	54W86	54W86
+ Power Exhaust + Elec. Heat 15 kW	54W85	54W85	54W85	54W85	54W85	54W85	54W85	54W85	54W85	54W85	54W85	54W85
+ Power Exhaust + Elec. Heat 30 kW	54W86	54W86	54W86	54W86	54W86	54W86	54W85	54W85	54W85	54W85	54W85	54W85
+ Power Exhaust + Elec. Heat 45 kW	54W86	54W86	54W86	54W86	54W86	54W87	54W85	54W85	54W85	54W85	54W85	54W85
+ Power Exhaust + Elec. Heat 60 kW	54W87	54W87	54W87	54W87	54W87	54W87	54W86	54W86	54W86	54W85	54W85	54W85
+ Power Exhaust + Elec. Heat 90 kW	¹ N/A	¹ N/A	¹ N/A	¹ N/A	¹ N/A	¹ N/A	54W86	54W86	54W86	54W86	54W86	54W86

¹ Disconnect must be field furnished.

ELECTRICAL ACCESSORIES - DISCONNECTS

20 TON | LCH240H4

Motor Horsepower	5		7.5		10		5	7.5	10	5	7.5	10
	208V	240V	208V	240V	208V	240V	480V	480V	480V	600V	600V	600V
Unit Only	54W86	54W86	54W86	54W86	54W86	54W86	54W85	54W85	54W85	54W85	54W85	54W85
+ Power Exhaust	54W86	54W86	54W86	54W86	54W86	54W86	54W85	54W85	54W85	54W85	54W85	54W85
+ Electric Heat 15 kW	54W85	54W85	54W85	54W85	54W85	54W85	54W85	54W85	54W85	54W85	54W85	54W85
+ Electric Heat 30 kW	54W86	54W86	54W86	54W86	54W86	54W86	54W85	54W85	54W85	54W85	54W85	54W85
+ Electric Heat 45 kW	54W86	54W86	54W86	54W87	54W86	54W87	54W85	54W85	54W85	54W85	54W85	54W85
+ Electric Heat 60 kW	54W87	54W87	54W87	54W87	54W87	54W87	54W86	54W86	54W86	54W85	54W85	54W85
+ Electric Heat 90 kW	¹ N/A	¹ N/A	¹ N/A	¹ N/A	¹ N/A	¹ N/A	54W86	54W86	54W86	54W86	54W86	54W86
+ Power Exhaust + Elec. Heat 15 kW	54W85	54W85	54W85	54W85	54W85	54W86	54W85	54W85	54W85	54W85	54W85	54W85
+ Power Exhaust + Elec. Heat 30 kW	54W86	54W86	54W86	54W86	54W86	54W86	54W85	54W85	54W85	54W85	54W85	54W85
+ Power Exhaust + Elec. Heat 45 kW	54W86	54W86	54W86	54W87	54W86	54W87	54W85	54W85	54W86	54W85	54W85	54W85
+ Power Exhaust + Elec. Heat 60 kW	54W87	54W87	54W87	54W87	54W87	54W87	54W86	54W86	54W86	54W85	54W85	54W86
+ Power Exhaust + Elec. Heat 90 kW	¹ N/A	¹ N/A	¹ N/A	¹ N/A	¹ N/A	¹ N/A	54W86	54W86	54W86	54W86	54W86	54W86

25 TON | LCH300S4

Motor Horsepower	5		7.5		10		5	7.5	10	5	7.5	10
	208V	240V	208V	240V	208V	240V	480V	480V	480V	600V	600V	600V
Unit Only	54W86	54W86	54W86	54W86	54W86	54W86	54W85	54W85	54W85	54W85	54W85	54W85
+ Power Exhaust	54W86	54W86	54W86	54W86	54W87	54W87	54W85	54W85	54W85	54W85	54W85	54W85
+ Electric Heat 15 kW	54W85	54W85	54W85	54W85	54W85	54W85	54W85	54W85	54W85	54W85	54W85	54W85
+ Electric Heat 30 kW	54W86	54W86	54W86	54W86	54W86	54W86	54W85	54W85	54W85	54W85	54W85	54W85
+ Electric Heat 45 kW	54W86	54W86	54W86	54W87	54W86	54W87	54W85	54W85	54W85	54W85	54W85	54W85
+ Electric Heat 60 kW	54W87	54W87	54W87	54W87	54W87	54W87	54W86	54W86	54W86	54W85	54W85	54W85
+ Electric Heat 90 kW	¹ N/A	¹ N/A	¹ N/A	¹ N/A	¹ N/A	¹ N/A	54W86	54W86	54W86	54W86	54W86	54W86
+ Power Exhaust + Elec. Heat 15 kW	54W85	54W85	54W85	54W85	54W85	54W86	54W85	54W85	54W85	54W85	54W85	54W85
+ Power Exhaust + Elec. Heat 30 kW	54W86	54W86	54W86	54W86	54W86	54W86	54W85	54W85	54W85	54W85	54W85	54W85
+ Power Exhaust + Elec. Heat 45 kW	54W86	54W86	54W86	54W87	54W86	54W87	54W85	54W85	54W86	54W85	54W85	54W85
+ Power Exhaust + Elec. Heat 60 kW	54W87	54W87	54W87	54W87	54W87	54W87	54W86	54W86	54W86	54W85	54W85	54W86
+ Power Exhaust + Elec. Heat 90 kW	¹ N/A	¹ N/A	¹ N/A	¹ N/A	¹ N/A	¹ N/A	54W86	54W86	54W86	54W86	54W86	54W86

¹ Disconnect must be field furnished.

ELECTRIC HEAT CAPACITIES

Volts Input	15 kW			30 kW			45 kW			60 kW			90 kW		
	kW Input	Btuh Output	No. of Stages	kW Input	Btuh Output	No. of Stages	kW Input	Btuh Output	No. of Stages	kW Input	Btuh Output	No. of Stages	kW Input	Btuh Output	No. of Stages
208	11.3	38,600	1	22.5	76,800	1	33.8	115,300	2	45.0	153,600	2	67.6	230,700	2
220	12.6	43,000	1	25.2	86,000	1	37.8	129,000	2	50.4	172,000	2	75.6	258,000	2
230	13.8	47,100	1	27.5	93,900	1	41.3	141,000	2	55.1	188,000	2	82.7	282,200	2
240	15.0	51,200	1	30.0	102,400	1	45.0	153,600	2	60.0	204,800	2	90.0	307,100	2
440	12.6	43,000	1	25.2	86,000	1	37.8	129,000	2	50.4	172,000	2	75.6	258,000	2
460	13.8	47,100	1	27.5	93,900	1	41.3	141,000	2	55.1	188,000	2	82.7	282,200	2
480	15.0	51,200	1	30.0	102,400	1	45.0	153,600	2	60.0	204,800	2	90.0	307,100	2
550	12.6	43,000	1	25.2	86,000	1	37.8	129,000	2	50.4	172,000	2	75.6	258,000	2
575	13.8	47,100	1	27.5	93,900	1	41.3	141,000	2	55.1	188,000	2	82.7	282,200	2
600	15.0	51,200	1	30.0	102,400	1	45.0	153,600	2	60.0	204,800	2	90.0	307,100	2

UNIT CLEARANCES

Unit With Economizer

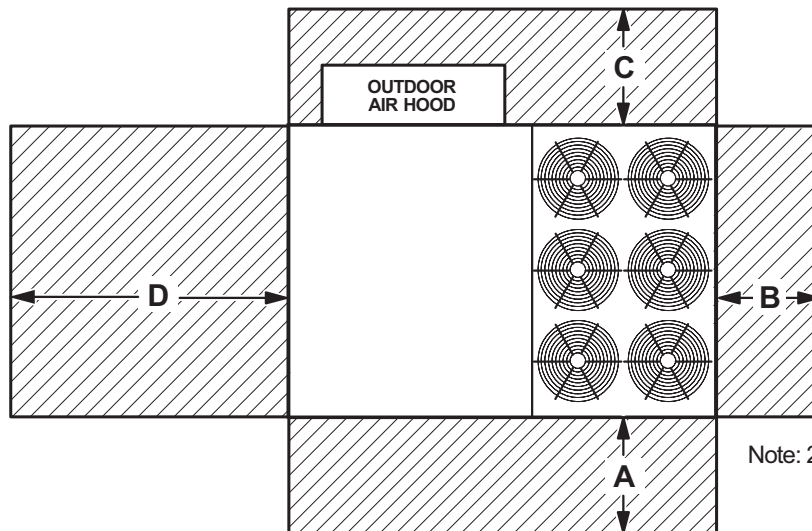

Note: 210-240-300 sizes shown

¹ Unit Clearance	A		B		C		D		Top Clearance
	in.	mm	in.	mm	in.	mm	in.	mm	
Service Clearance	60	1524	36	914	36	934	66	1676	Unobstructed
Minimum Operation Clearance	45	1143	36	914	36	914	41	1041	

NOTE - Entire perimeter of unit base requires support when elevated above the mounting surface.

¹ Service Clearance - Required for removal of serviceable parts.

Minimum Operation Clearance - Required clearance for proper unit operation.

OUTDOOR SOUND DATA

Unit Model Number	Octave Band Sound Power Levels dB, re 10 ⁻¹² Watts - Center Frequency - Hz							¹ Sound Rating Number (dBA)
	125	250	500	1000	2000	4000	8000	
156	71	78	81	81	76	71	63	86
180	80	83	87	88	84	80	71	93
210, 240, 300	79	84	88	89	85	82	73	94

Note - The octave sound power data does not include tonal corrections.

¹ Sound Rating Number according to AHRI Standard 370-2001 (includes pure tone penalty). Sound Rating Number is the overall A-Weighted Sound Power Level, (LWA), dBA (100 Hz to 10,000 Hz).

WEIGHT DATA

Model Number	Outdoor Coil	Net		Shipping		Outdoor Coil	Net		Shipping	
		lbs.	kg	lbs.	kg		lbs.	kg		
156 Base Unit	Environ™	1785	810	1985	900	Fin/Tube	1850	839	2050	930
156 Max. Unit	Environ™	2065	937	2265	1027	Fin/Tube	2130	966	2330	1057
180 Base Unit	Environ™	1965	891	2165	982	Fin/Tube	2070	939	2270	1030
180 Max. Unit	Environ™	2245	1018	2445	1109	Fin/Tube	2350	1066	2550	1157
210 Base Unit	Environ™	2090	948	2290	1039	Fin/Tube	2180	989	2380	1080
210 Max. Unit	Environ™	2380	1080	2580	1170	Fin/Tube	2470	1120	2670	1211
240 Base Unit	Environ™	2175	987	2375	1077	Fin/Tube	2280	1034	2480	1125
240 Max. Unit	Environ™	2465	1118	2665	1209	Fin/Tube	2570	1166	2770	1256
300 Base Unit	Environ™	2300	1043	2500	1134	Fin/Tube	2365	1073	2565	1163
300 Max. Unit	Environ™	2590	1175	2790	1266	Fin/Tube	2655	1204	2855	1295

NOTE - Max. Unit is the unit with ALL INTERNAL OPTIONS Installed. (Economizer, Standard Static Power Exhaust Fans, Controls, etc.). Does not include accessories EXTERNAL to unit.

OPTIONS / ACCESSORIES

Description	Shipping Weight	
	lbs.	kg
CEILING DIFFUSERS		
Step-Down		
	RTD11-185S	168
	RTD11-275S	238
Flush		
	FD11-185S	168
	FD11-275S	238
Transitions		
	C1DIFF33C-1	80
	C1DIFF34C-1	75

ECONOMIZER / OUTDOOR AIR / EXHAUST

Economizer

Economizer Dampers	102	46
Barometric Relief Dampers (downflow)	30	14
Barometric Relief Dampers (horizontal)	20	9
Outdoor Air Damper Hood (downflow)	65	29

Outdoor Air Dampers

Outdoor Air Damper Section (downflow) - Automatic (including Hood)	18	39
Outdoor Air Damper Section (downflow) - Manual (including Hood)	10	22

Power Exhaust

	62	28
--	----	----

ELECTRIC HEAT

15 kW	59	27
30 kW	59	27
45 kW	76	34
60 kW	76	34
90 kW	84	38

HUMIDITROL® DEHUMIDIFICATION SYSTEM

Humiditrol® Dehumidification Option (Net Weight)	50	23
--	----	----

MSAV® (MULTI-STAGE AIR VOLUME) SUPPLY AIR BLOWER OPTION

Variable Frequency Drive (VFD) and associated components	10	5
--	----	---

ROOF CURBS

Hybrid Roof Curbs, Downflow

8 in. height	75	34
14 in. height	105	48
18 in. height	125	57
24 in. height	155	70

Adjustable Pitch Curb, Downflow

14 in. height	262	119
---------------	-----	-----

Horizontal, Standard

26 in. height	470	213
37 in. height	505	229
30 in. height	575	261
41 in. height	610	277

PACKAGING

LTL Packaging (less than truck load)	Engergence® Packaged Electric / Electric 13 to 25 Ton / Page 55
--------------------------------------	---

CORNER WEIGHTS

CENTER OF GRAVITY

Model No.	AA		BB		CC		DD		EE		FF	
	lbs.	kg	lbs.	kg	lbs.	kg	lbs.	kg	in.	mm	in.	mm
LCH156 Base Unit (Environ™ Coil)	428	195	346	157	456	207	554	252	48-1/2	1232	39-1/2	1003
LCH156 Max. Unit (Environ™ Coil)	538	244	429	195	489	222	609	277	48	1219	42-3/4	1086
LCH156 Base Unit (Fin/Tube Coil)	431	195	376	171	486	220	557	253	50-1/4	1276	39-3/4	1010
LCH156 Max. Unit (Fin/Tube Coil)	540	245	459	208	519	235	611	277	49-1/2	1257	42-3/4	1086

Base Unit - The unit with NO INTERNAL OPTIONS.

Max. Unit - The unit with ALL INTERNAL OPTIONS Installed. (Economizer, Standard Static Power Exhaust Fans, Controls, etc.). Does not include accessories external to unit.

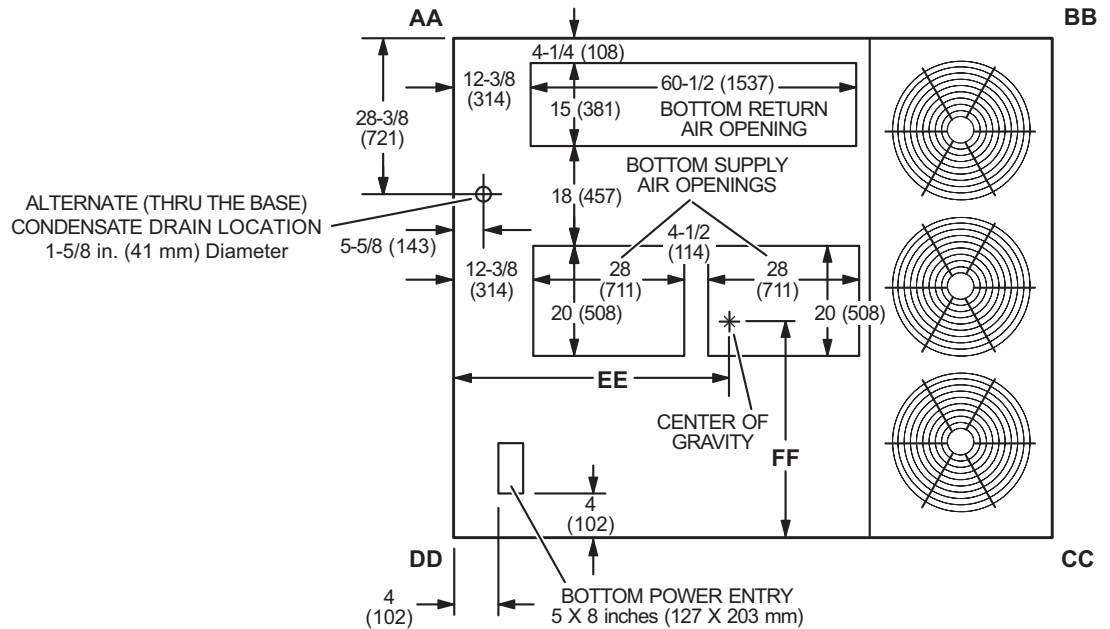

TOP VIEW

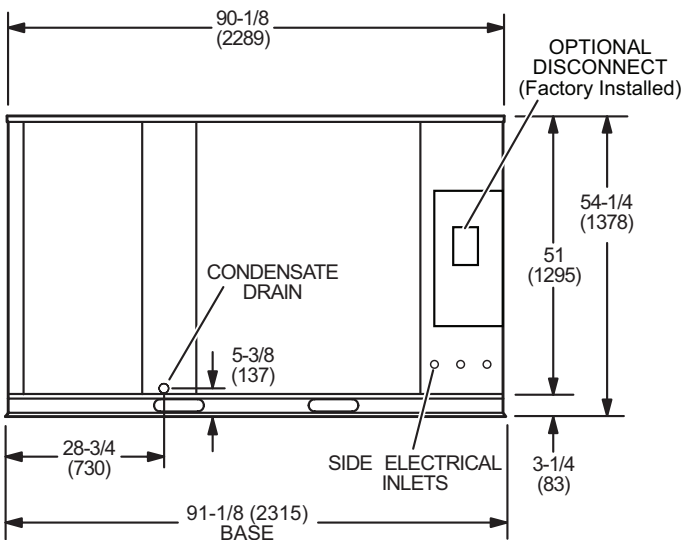

END VIEW

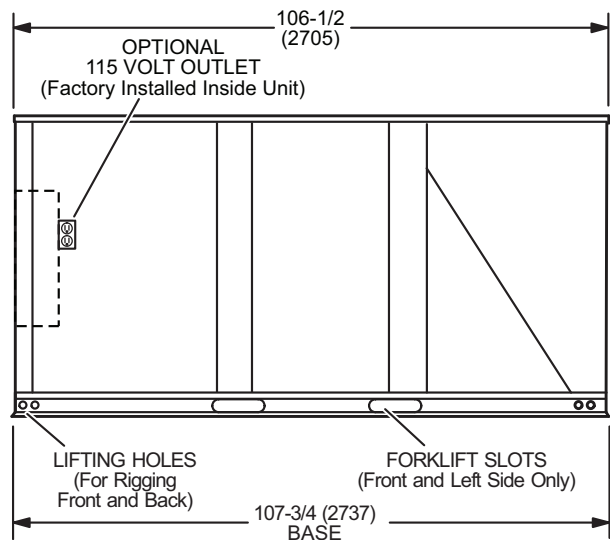

SIDE VIEW

DIMENSIONS - UNIT

LCH180

CORNER WEIGHTS

CENTER OF GRAVITY

Model No.	AA		BB		CC		DD		EE		FF	
	lbs.	kg	lbs.	kg	lbs.	kg	lbs.	kg	in.	mm	in.	mm
LCH180 Base Unit (Environ™ Coil)	441	201	403	183	543	247	577	262	52	1321	39-1/4	997
LCH180 Max. Unit (Environ™ Coil)	545	248	485	221	577	262	638	290	51	1295	42	1067
LCH180 Base Unit (Fin/Tube Coil)	441	200	456	207	596	270	577	262	54-3/4	1391	39-1/2	1003
LCH180 Max. Unit (Fin/Tube Coil)	545	247	538	244	629	285	638	289	53-1/2	1359	42	1067

Base Unit - The unit with NO INTERNAL OPTIONS.

Max. Unit - The unit with ALL INTERNAL OPTIONS Installed. (Economizer, Standard Static Power Exhaust Fans, Controls, etc.). Does not include accessories external to unit.

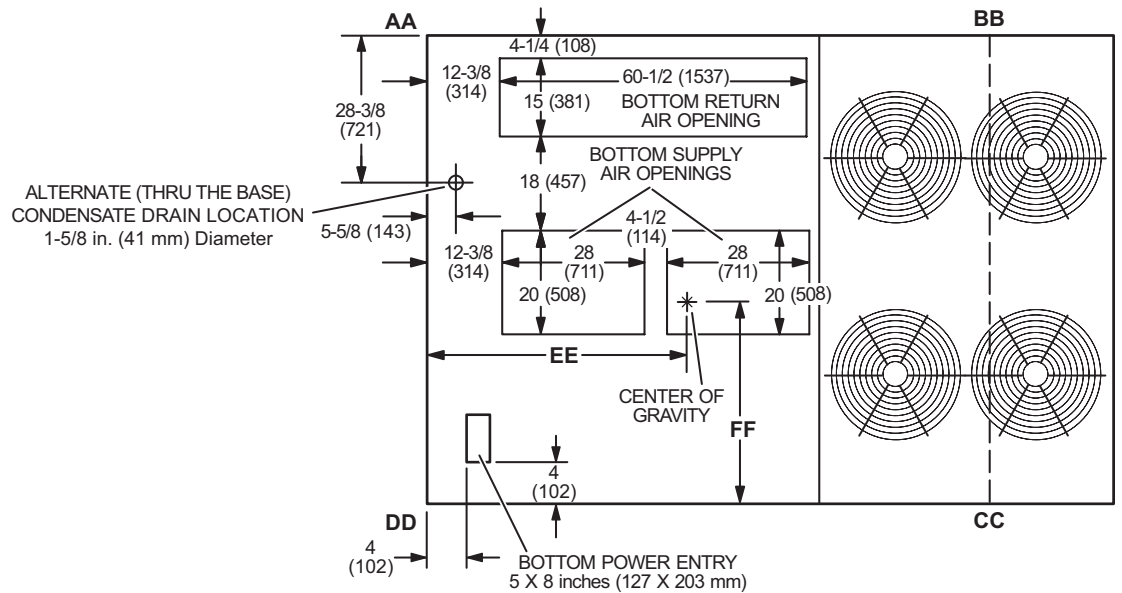

TOP VIEW

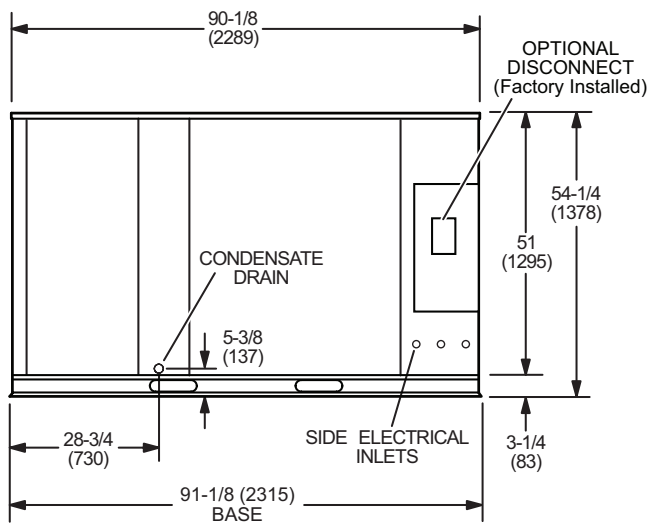

END VIEW

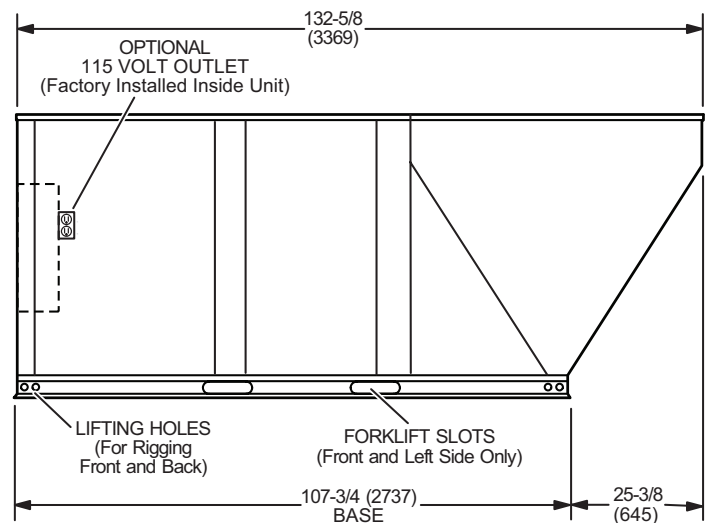

SIDE VIEW

DIMENSIONS - UNIT

LCH210 | LCH240 | ICH300

CORNER WEIGHTS

CENTER OF GRAVITY

Model No.	AA		BB		CC		DD		EE		FF	
	lbs.	kg	lbs.	kg	lbs.	kg	lbs.	kg	in.	mm	in.	mm
LCH210 Base Uni (Environ™ Coil)	452	205	448	204	600	273	590	268	54	1372	39-1/4	997
LCH210 Max. Unit (Environ™ Coil)	557	253	536	244	635	288	652	296	53	1346	42	1067
LCH210 Base Unit (Fin/Tube Coil)	452	205	493	224	645	293	590	268	56-1/4	1429	39-1/2	1003
LCH210 Max. Unit (Fin/Tube Coil)	557	253	581	264	680	308	652	296	55	1397	42	1067
LCH240 Base Unit (Environ™ Coil)	462	210	461	210	634	288	617	281	54-1/2	1384	38-3/4	984
LCH240 Max. Unit (Environ™ Coil)	568	258	550	250	668	304	679	308	53-1/2	1359	41-1/2	1054
LCH240 Base Unit (Fin/Tube Coil)	462	210	514	233	687	312	617	280	56-3/4	1441	39	991
LCH240 Max. Unit (Fin/Tube Coil)	568	258	603	274	721	327	679	308	55-1/2	1410	41-1/2	1054
LCH300 Base Unit (Environ™ Coil)	466	212	487	221	689	313	660	300	55	1397	37-3/4	959
LCH300 Max. Unit (Environ™ Coil)	574	261	578	263	723	329	718	326	54	1372	40-1/2	1029
LCH300 Base Unit (Fin/Tube Coil)	469	213	518	235	724	329	656	298	56-1/2	1435	38	965
LCH300 Max. Unit (Fin/Tube Coil)	575	261	606	275	758	344	719	327	55-1/4	1403	40-1/2	1029

Base Unit - The unit with NO INTERNAL OPTIONS.

Max. Unit - The unit with ALL INTERNAL OPTIONS Installed. (Economizer, Standard Static Power Exhaust Fans, Controls, etc.). Does not include accessories external to unit.

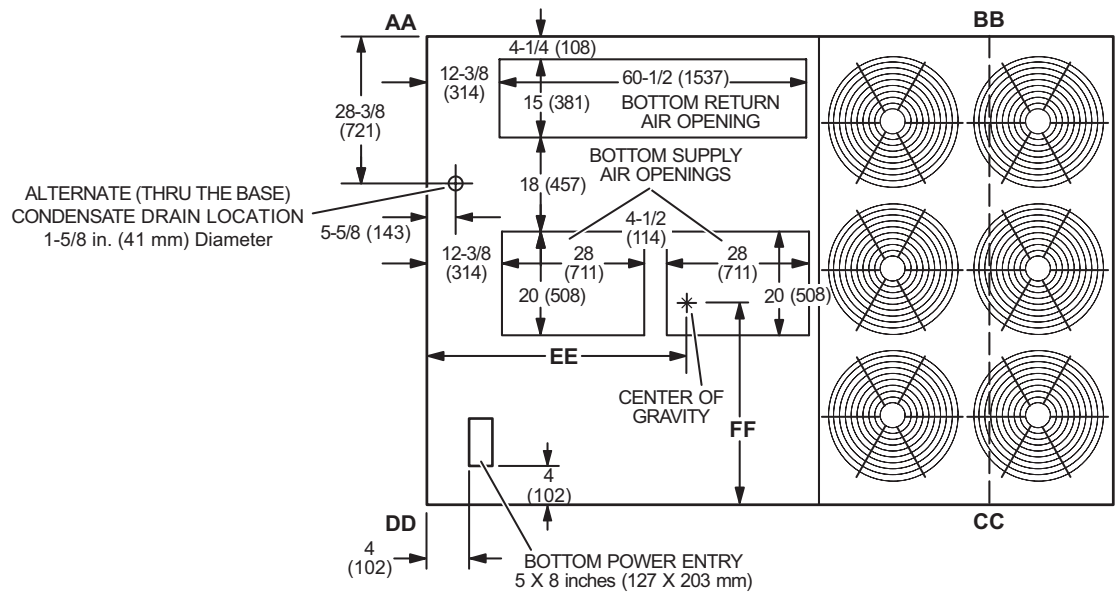

TOP VIEW

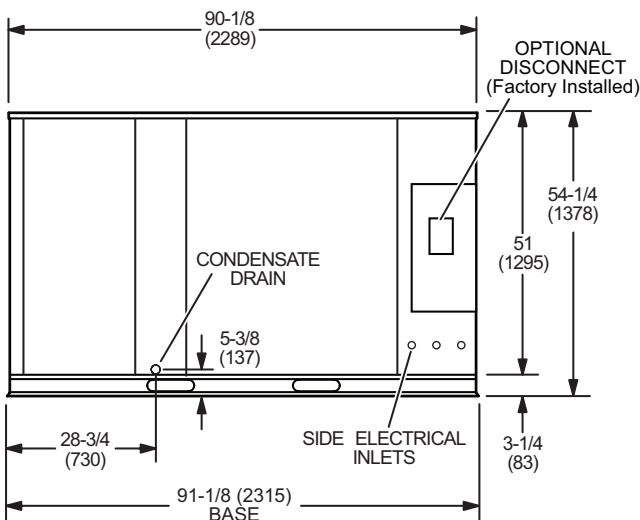

END VIEW

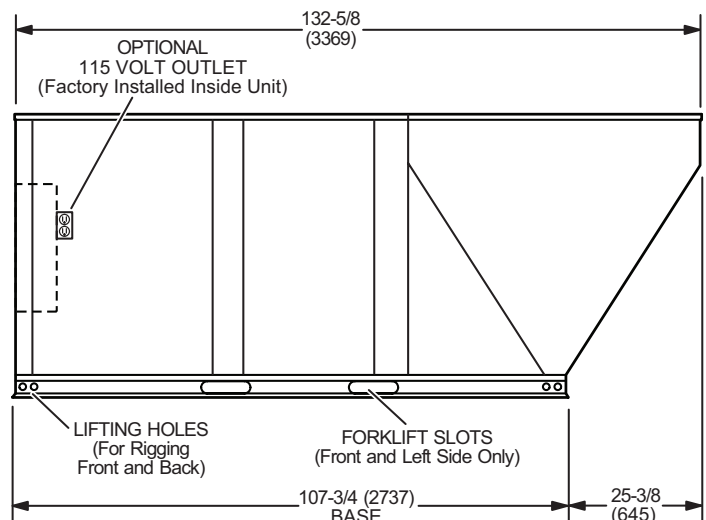

SIDE VIEW

OUTDOOR AIR HOOD DETAIL

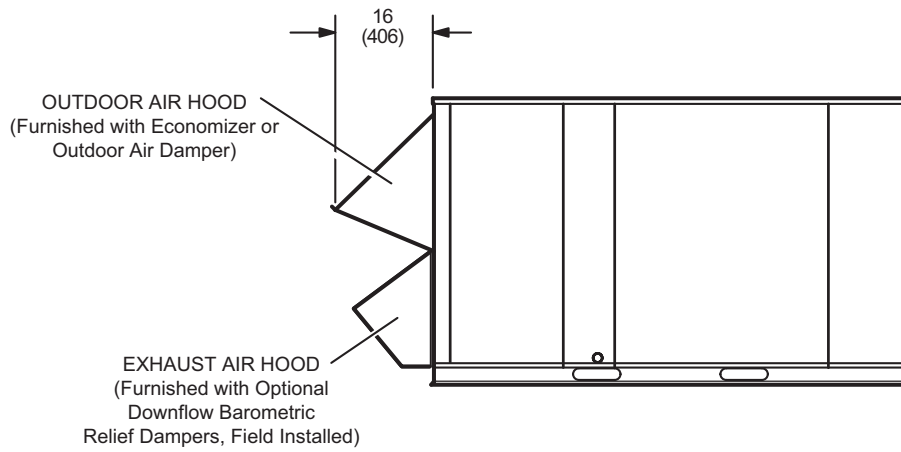

OPTIONAL HORIZONTAL BAROMETRIC RELIEF DAMPERS WITH HOOD

(Field installed in horizontal return air duct adjacent to unit)

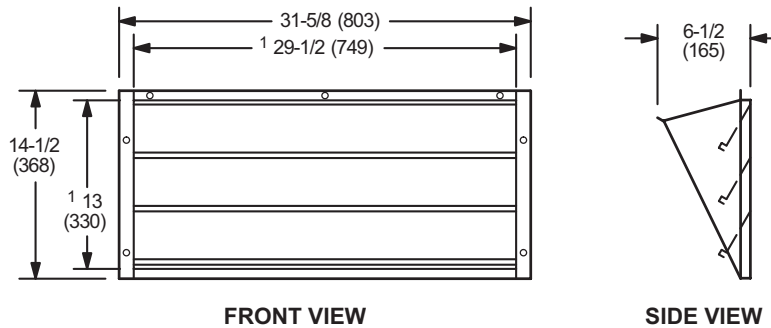

NOTE - Two furnished per order no.
¹ NOTE - Opening size required in return air duct.

DIMENSIONS - ACCESSORIES

HYBRID ROOF CURBS - DOUBLE DUCT OPENING

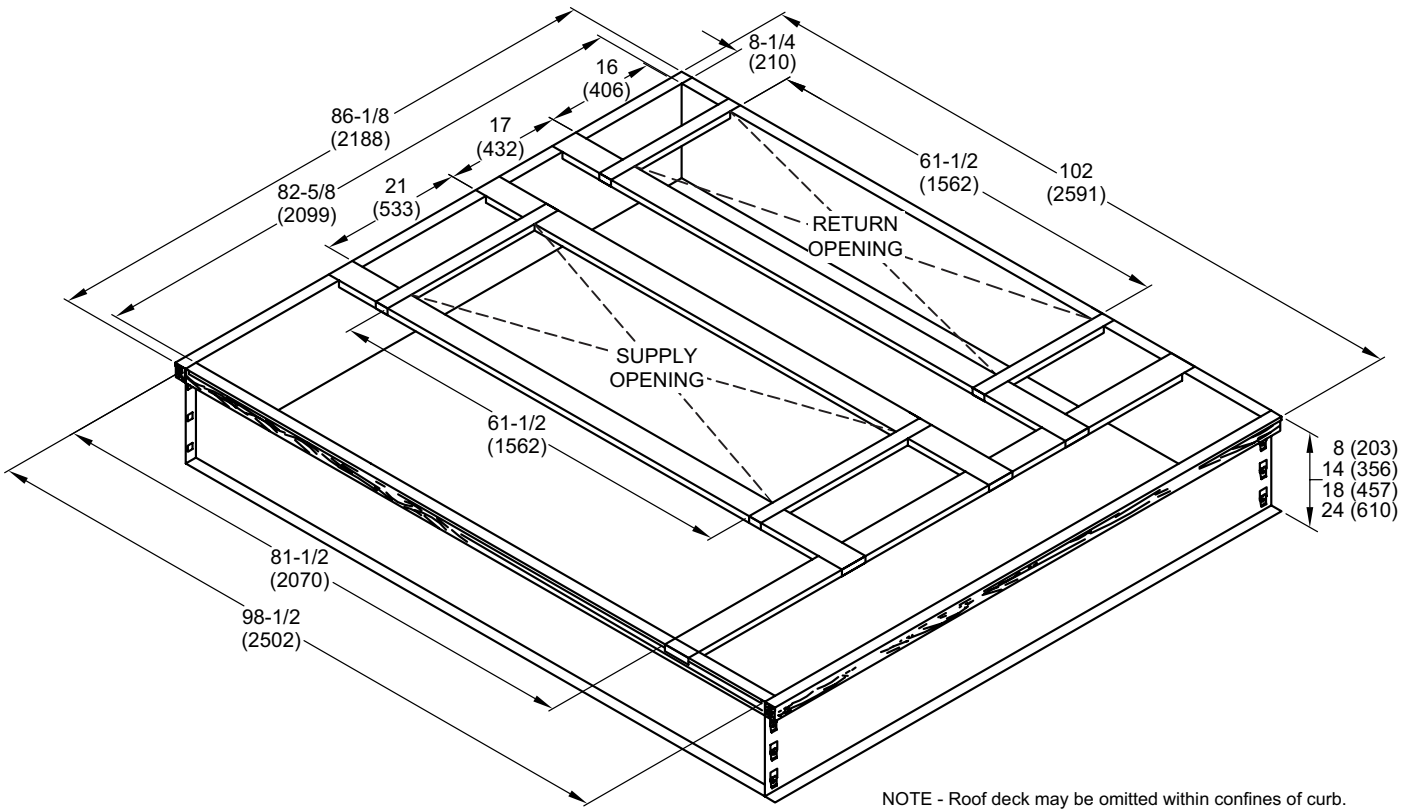

TYPICAL FLASHING DETAIL FOR ROOF CURB

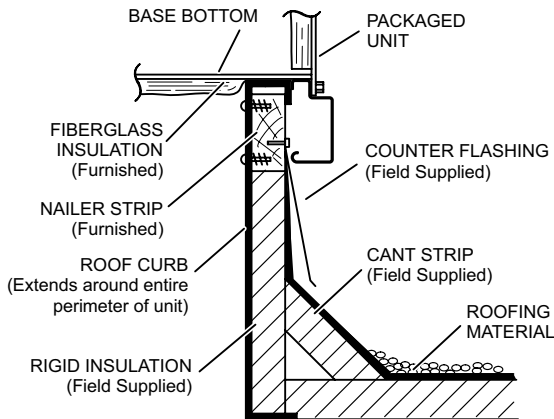

DETAIL ROOF CURB

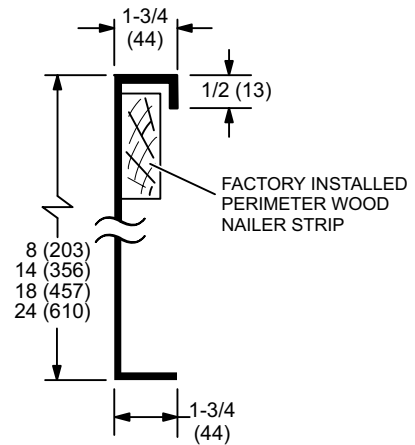

DIMENSIONS - ACCESSORIES

ADJUSTABLE PITCH CURB - DOUBLE DUCT OPENING

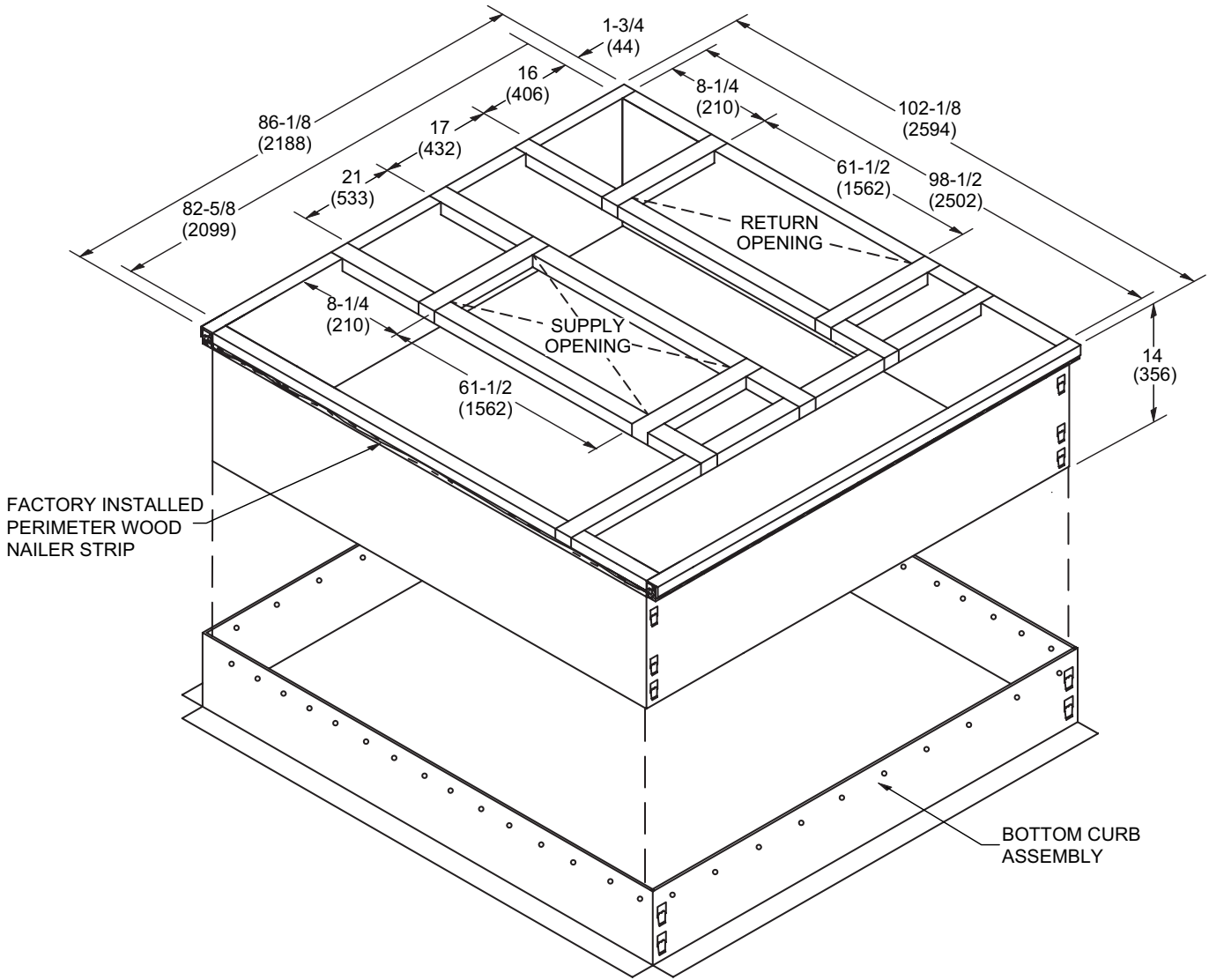

NOTE - Maximum slope pitch is 3/4 in. per 1 foot (19 mm per 305 mm) in any one direction.

TYPICAL FLASHING DETAIL FOR ROOF CURB

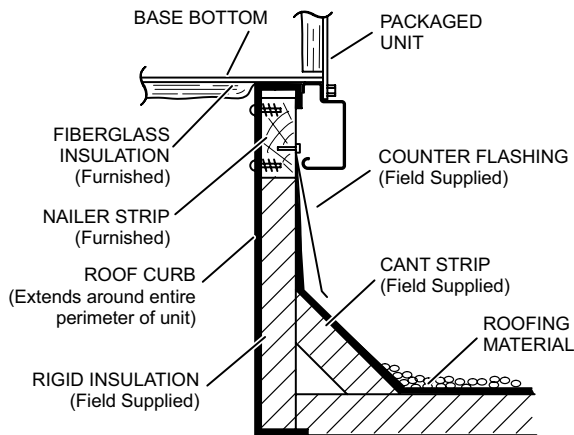

DETAIL ROOF CURB

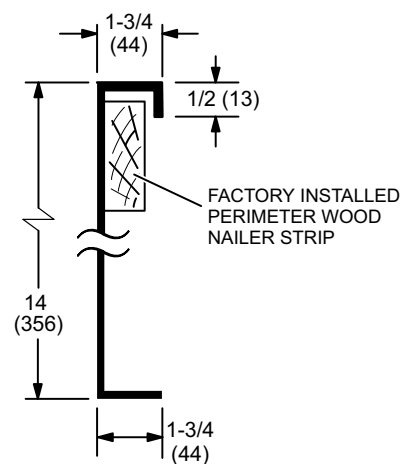

DIMENSIONS - ACCESSORIES

ROOF CURBS WITH SUPPLY & RETURN AIR TRANSITIONS FOR CEILING DIFFUSERS

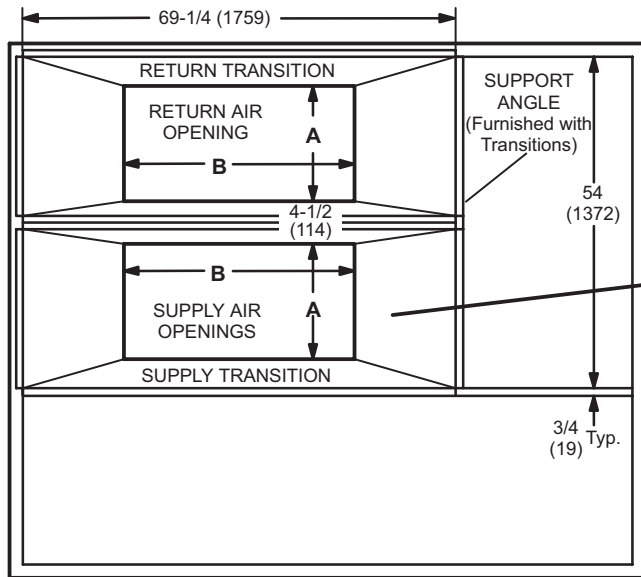

TOP VIEW

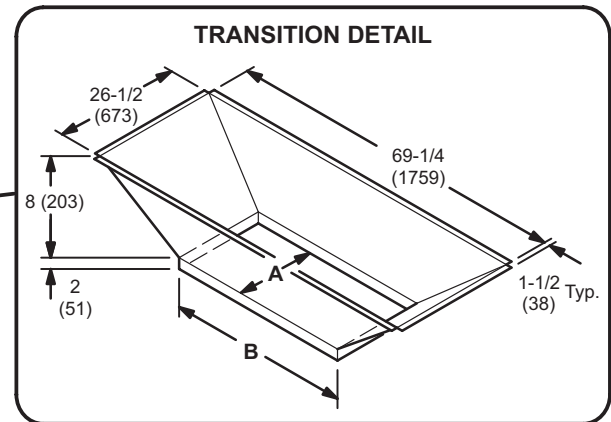

TRANSITION OPENING SIZES

Model Number	A		B	
	inch	mm	inch	mm
C1DIFF33C-1	18	457	36	914
C1DIFF34C-1	24	610	48	1219

DIMENSIONS - ACCESSORIES

HORIZONTAL ROOF CURBS – Requires Optional Horizontal Return Air Panel Kit

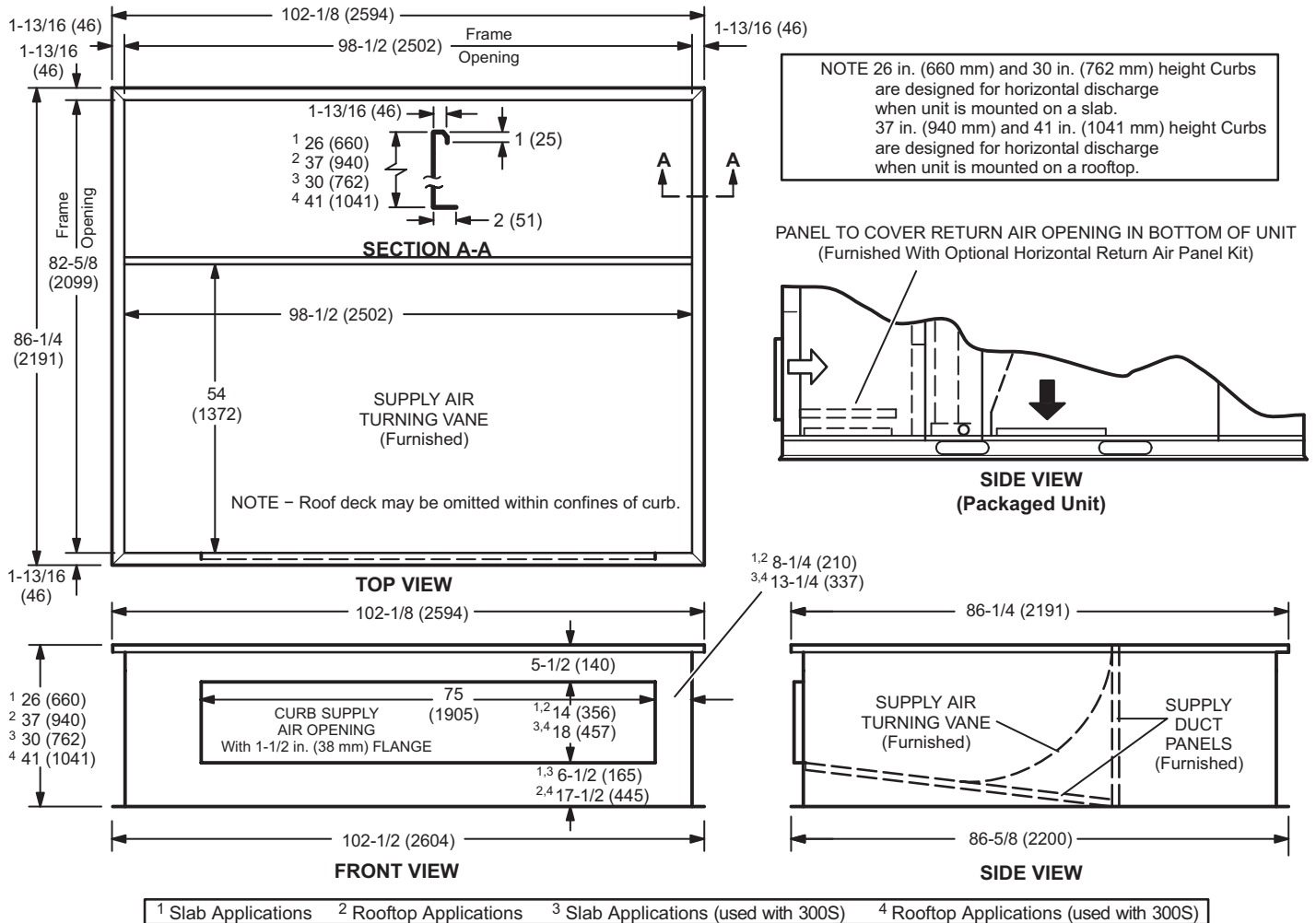

HORIZONTAL SUPPLY AND RETURN AIR OPENINGS WITH HORIZONTAL ROOF CURB

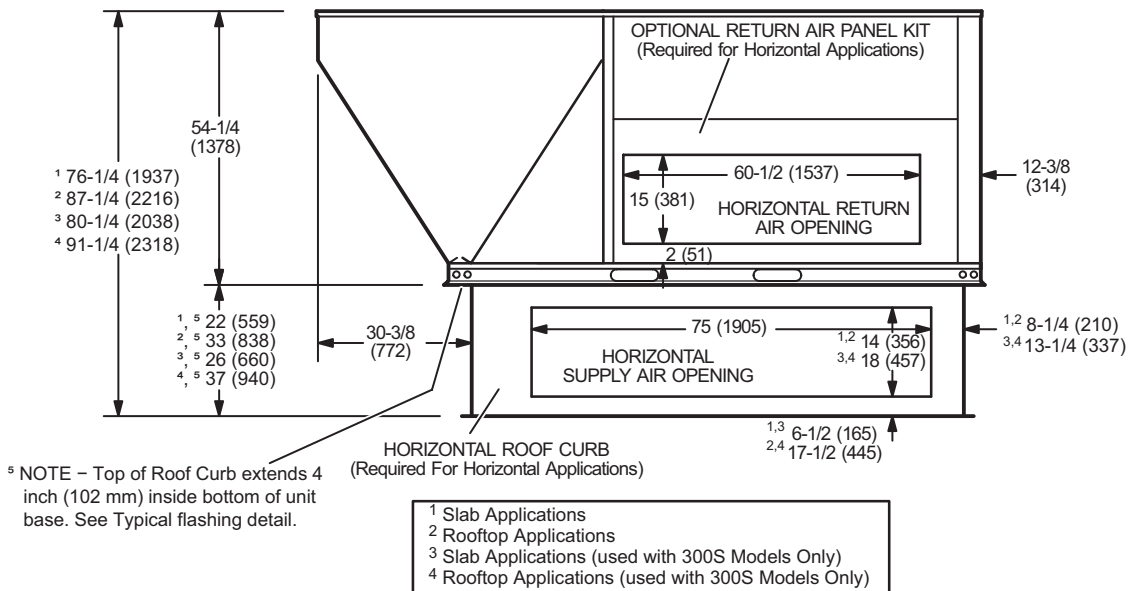

DIMENSIONS - ACCESSORIES

COMBINATION CEILING SUPPLY AND RETURN DIFFUSERS

STEP-DOWN CEILING DIFFUSER

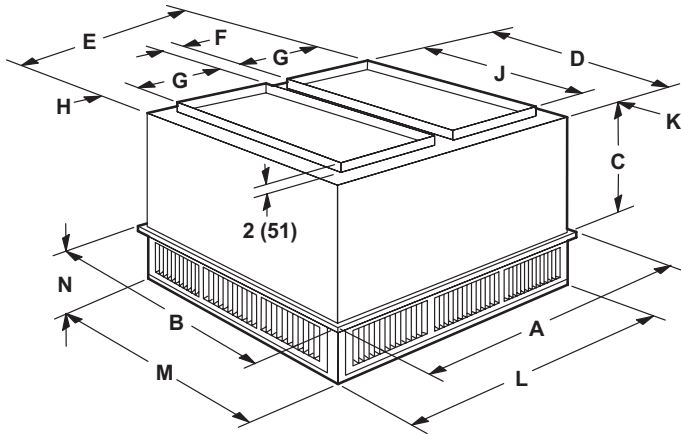

FLUSH CEILING DIFFUSER

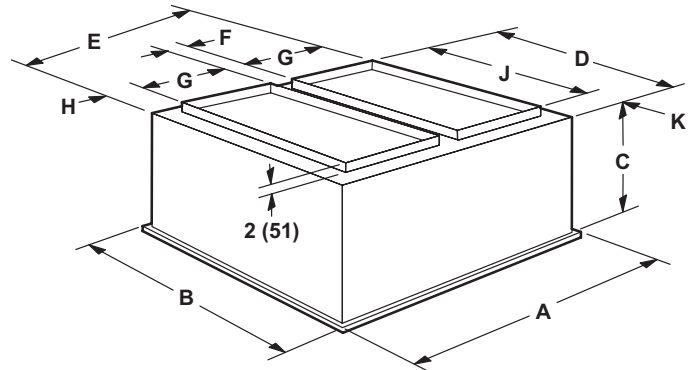

Model Number		RTD11-185S	RTD11-275S
A	in.	47-5/8	59-5/8
	mm	1210	1514
B	in.	47-5/8	59-5/8
	mm	1210	1514
C	in.	24-5/8	30-5/8
	mm	625	778
D	in.	45-1/2	57-1/2
	mm	1156	1461
E	in.	45-1/2	57-1/2
	mm	1156	1461
F	in.	4-1/2	4-1/2
	mm	114	114
G	in.	18	24
	mm	457	610
H	in.	2-1/2	2-1/2
	mm	64	64
J	in.	36	48
	mm	914	1219
K	in.	4-3/4	4-3/4
	mm	121	121
L	in.	45-1/2	57-1/2
	mm	1156	1461
M	in.	45-1/2	57-1/2
	mm	1156	1461
N	in.	10-1/8	11-1/8
	mm	257	283
Duct Size	in.	18 x 36	24 x 48
	mm	457 x 914	610 x 1219

Model Number		FD11-185S	FD11-275S
A	in.	47-5/8	59-5/8
	mm	1210	1514
B	in.	47-5/8	59-5/8
	mm	1210	1514
C	in.	29-1/4	35-1/4
	mm	743	895
D	in.	45	57
	mm	1143	1148
E	in.	45	57
	mm	1143	1448
F	in.	4-1/2	4-1/2
	mm	114	114
G	in.	18	24
	mm	457	610
H	in.	2-1/4	2-1/4
	mm	57	57
J	in.	36	48
	mm	914	1219
K	in.	4-1/2	4-1/2
	mm	114	114
Duct Size	in.	18 x 36	24 x 48
	mm	457 x 914	610 x 1219

REVISIONS

Sections	Description of Change
Options/Accessories	Added MERV 16 air filters. Copper Drain Trap is field installed only.



Visit us at www.Lennox.com

For the latest technical information, www.LennoxCommercial.com

Contact us at 1-800-4-LENNOX

NOTE - Due to Lennox' ongoing commitment to quality, Specifications, Ratings and Dimensions subject to change without notice and without incurring liability. Improper installation, adjustment, alteration, service or maintenance can cause property damage or personal injury. Installation and service must be performed by a qualified installer and servicing agency.

©2022 Lennox Industries, Inc.