



COMMERCIAL
PRODUCT SPECIFICATIONS

Bulletin No. 210560
 October 2023
 Supersedes March 2023



Unit shown with optional
 Hinged Louvered Condenser
 Section Panels



SMART WIRE™ SYSTEM

35 to 50 Tons

Net Cooling Capacity - 410,000 to 565,000 Btuh
 Optional Electric Heat - 30 to 180 kW

MODEL NUMBER IDENTIFICATION

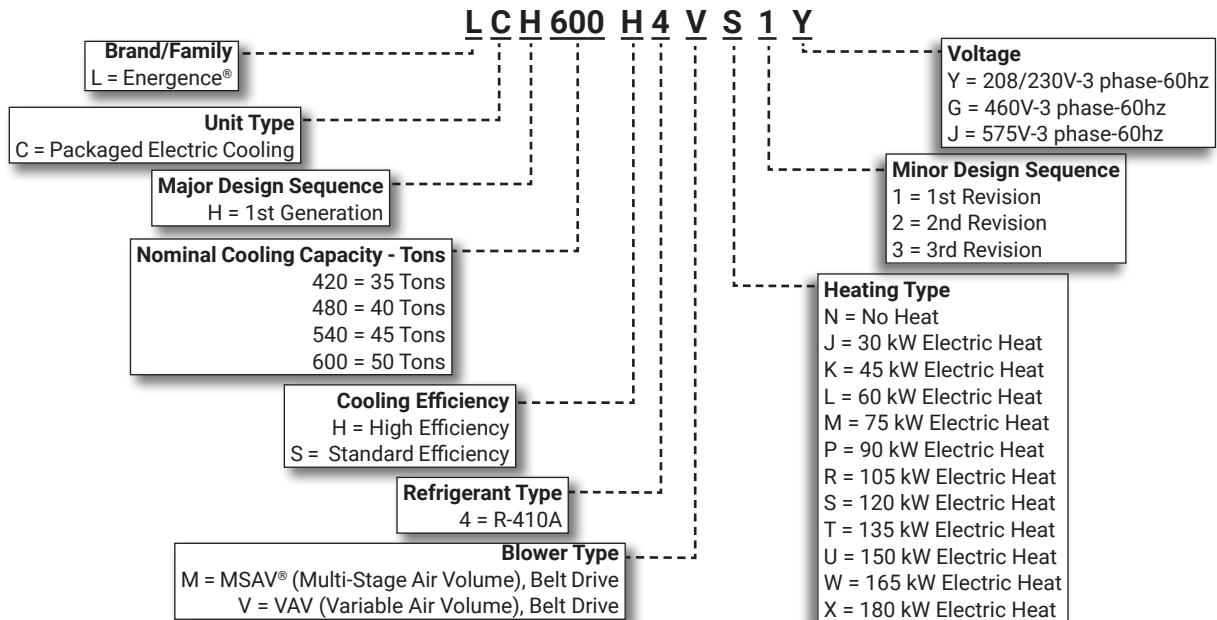

FEATURE HIGHLIGHTS

- Provides high performance and energy efficiency in one unit
- Low height unit provides more architectural flexibility and can reduce installation costs associated with hiding it from sight
- Wide variety of factory-installed and tested options means faster installations and more reliable start-ups
- Hinged access panels with easy access to components and straight outdoor coils speed maintenance, while common replacement parts reduce required inventory
- Save energy with an ASHRAE 90.1 compliant standard-efficiency model or maximize savings with a high-efficiency model

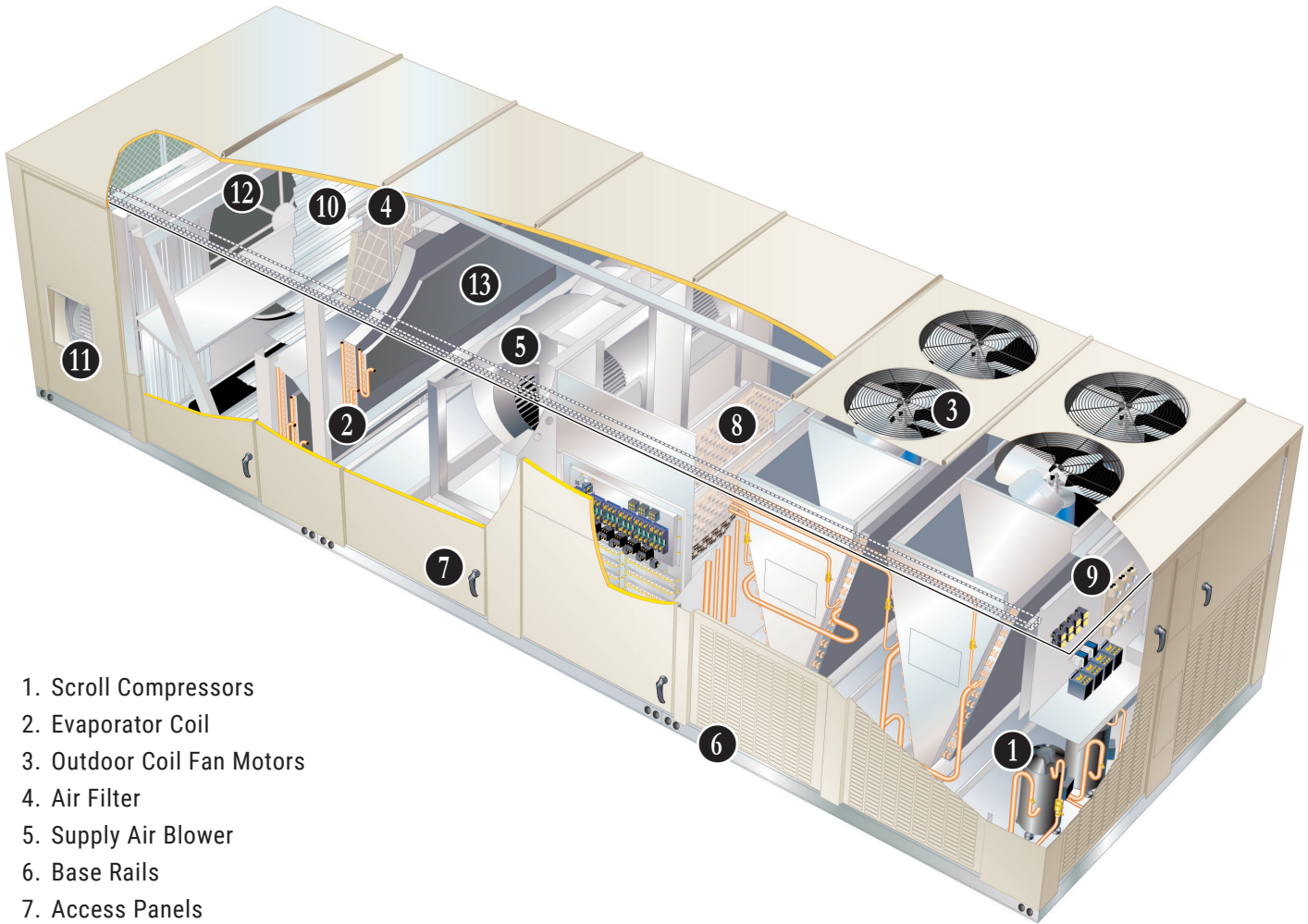

1. Scroll Compressors
2. Evaporator Coil
3. Outdoor Coil Fan Motors
4. Air Filter
5. Supply Air Blower
6. Base Rails
7. Access Panels
8. Electric Heat (option)
9. Prodigy 2.0 Unit Controller
10. High Performance Economizer (option)
11. Power Exhaust (option)
12. Energy Recovery Wheel (ERW) (option)
13. Humiditrol® Dehumidification System (option)

CONTENTS

Approvals And Warranty	3
Blower Data	53
Control System	8
Dimensions - Accessories	86
Dimensions - Unit - Horizontal Airflow	85
Dimensions - Unit - Vertical Airflow	84
Electrical Data	63
Electric Heat Capacities	82
Electric Heat Electrical Data	82
Energy Recovery Wheel Specifications	62
Feature Highlights	2
Features And Benefits	4
Humiditrol® Dehumidification System Ratings	50
Installation/Service Clearances	83
Model Number Identification	1
Optional Conventional Temperature Control Systems	14
Options / Accessories	29
Point Loading	88
Ratings	39
Sequence Of Operation	16
Specifications - 35 Ton High Efficiency	33
Specifications - 35 Ton Standard Efficiency	32
Specifications - 40 Ton High Efficiency	35
Specifications - 40 Ton Standard Efficiency	34
Specifications - 45 Ton Standard Efficiency	36
Specifications - 50 Ton Standard Efficiency	37
Specifications - Optional Power Exhaust	31
Weight Data	87

APPROVALS AND WARRANTY

APPROVALS

- ETL listed
- Components bonded for grounding to meet safety standards for servicing required by UL, CSA, and National and Canadian Electrical Codes
- Tested at conditions included in AHRI Standard 340/360
- ASHRAE 90.1 compliant
- Meets DOE 2018 energy efficiency standards
- MSAV® models meet California Code of Regulations, Title 24 requirements for staged airflow
- ISO 9001 Registered Manufacturing Quality System

WARRANTY

- Compressor - Limited five years
- Prodigy® 2.0 Unit Controller - Limited three years
- Variable-Frequency Drive (VFD) (optional) - Limited five years
- High Performance Economizers (optional) - Limited five years
- All other covered components - Limited one year

FEATURES AND BENEFITS

COOLING SYSTEM

- Designed to maximize sensible and latent cooling performance at design conditions
- Two efficiency levels provide flexibility
- System can operate from 0°F to 125°F without any additional controls
- Four, independent compressor circuits

1 Scroll Compressors

- Scroll compressors on all models for high performance, reliability and quiet operation
- Resiliently mounted on rubber grommets for quiet operation



Compressor Crankcase Heaters

- Protects against refrigerant migration that can occur during off-cycles

Thermal Expansion Valves

- Ensures optimal performance throughout the application range
- Removable element head

Filter/Driers

- High capacity filter/driers protect the system from dirt and moisture

High Pressure Switches

- Protects the compressor from overload conditions such as dirty condenser coils, blocked refrigerant flow or loss of outdoor fan operation
- Automatic reset

Low Pressure Switches

- Protects the compressor from low pressure conditions such as low refrigerant charge or low air flow
- Automatic reset

Indoor Coil Freeze Protection

- Protects the evaporator coil from damaging ice build-up due to conditions such as low air flow or low refrigerant charge

Coil Construction

- Copper tube construction
- Enhanced rippled-edge aluminum fins
- Flared shoulder tubing connections
- Silver soldered construction for improved heat transfer
- Factory leak tested

2 Evaporator Coil

- Cross row circuiting with rifled copper tubing optimizes both sensible and latent cooling capacity
- Low fin per inch count minimizes air pressure drop
- All models have row-split evaporator coils designed to keep condensate water off of an inactive part of the coil so the condensate will not re-enter the air stream

Condenser Coil

- Slab design
- Protected from hail or contact damage

Condensate Drain Pan

- Reversible polypropylene pan with positive slope
- Drain connection extends outside unit

3 Outdoor Coil Fan Motors

- Thermal overload protected
- Permanently lubricated ball bearings
- Shaft up
- Wire basket mount

Outdoor Coil Fan

- PVC coated fan guard furnished

Required Selections

Cooling Efficiency

- Specify either standard or high efficiency

Options/Accessories

Factory Installed

Discharge Air Temperature Sensor

- Sensor sends information to the unit controller to cycle up to 4 stages of heating or cooling to maintain discharge air setpoints for heating or cooling
- Optional for MSAV units (single zone or bypass zoning control)
- Automatically furnished with all Variable Air Volume (VAV) units
- Sensor is shipped with unit for remote field installation in supply duct

Drain Pan Overflow Switch

- Monitors condensate level in drain pan, shuts down unit if drain becomes clogged

Fresh Air Tempering

- Provides heating and cooling as needed to maintain the supply air temperature within a comfort range, regardless of the thermostat demand
- Sensor ships with unit but must be field installed in the supply air duct
- Requires change to Unit Controller parameter in the field to activate this mode of operation

Hot Gas Bypass

- Bypasses hot gas from the first stage compressor to the suction line during low airflow operation to help prevent coil frosting and compressor damage
- Allows operation down to 12.5% of nominal capacity

NOTE - Not available with Humiditrol® option.

Service Valves

- Fully serviceable brass valves installed in discharge & liquid lines

Spring Isolation

- Spring isolation (2 inch diameter springs) under compressor deck
- Rubber grommets under each compressor
- Blocked for shipment to prevent movement

Stainless Steel Drain Pan

- Non-corrosive drain pan

FEATURES AND BENEFITS

AIR FILTERS

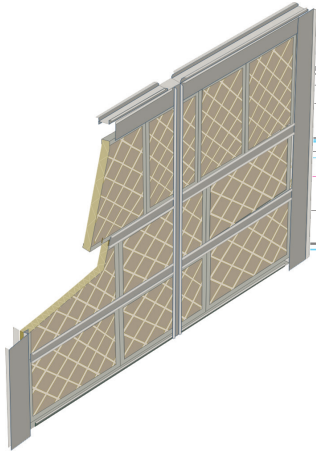

- 4 • Disposable 2-inch pleated MERV 4 filters (Minimum Efficiency Reporting Value based on ASHRAE 52.2)

Options/Accessories

MERV 8 Filters

- Disposable, 2-inch or 4-inch pleated MERV 8

MERV 13 High Efficiency Filters

- Disposable, 2-inch or 4-inch pleated MERV 13

Cleanable Filters

- 2-inch metal mesh

BLOWER

A wide selection of supply air blower options are available to meet a variety of air flow requirements.

Standard or variable frequency drives (VFD) are available.

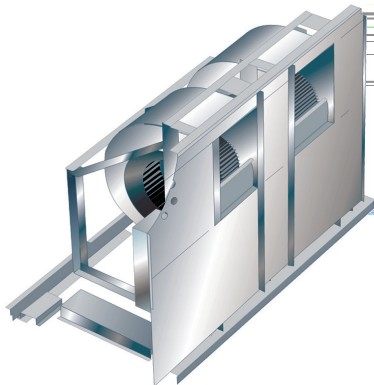

Motor

- Overload protected
- Ball bearings
- Belt drive motors are offered in several different sizes to maximize air performance

Motor Efficiency

- All blower motors 5 hp and above meet minimum energy efficiency standards in accordance with the Energy Independence and Security Act (EISA) of 2007

5 Supply Air Blower

- Internally braced
- Forward curved blades
- Blower wheel is statically and dynamically balanced
- Ball bearings
- Adjustable pulley (allows speed change)
- Grease fittings

Supply Static Transducer (VAV Models Only)

- Transducer sends information to the unit controller to control VFD blower speed
- Transducer is shipped with the unit for remote field installation in the supply duct

NOTE - Units equipped a Variable Frequency Drive (VFD) are designed to operate on balanced, three-phase power. Operating units on unbalanced three-phase power will reduce the reliability of all electrical components in the unit. Unbalanced power is a result of the power delivery system supplied by the local utility company. Factory-installed inverters are sized to drive blower motors with an equivalent current rating using balanced three-phase power. If unbalanced three-phase power is supplied the installer must replace the existing factory-installed inverter with an inverter that has a higher current rating to allow for the imbalance. Refer to the installation instructions for additional information and replacement information.

Required Selections

Blower

- Specify Variable Air Volume (VAV) or MSAV® (Multi-Stage Air Volume)
- See Blower Data Table for specifications
- Order one drive kit, see Drive Kit Specifications Table

Options/Accessories

Factory Installed

Spring Isolation

- Spring isolation (2-inch diameter springs) under blower frame
- Blocked for shipment to prevent movement

Supply VFD Blower Bypass

- Allows Variable Air Volume (VAV) and MSAV® (Multi-Stage Air Volume) units to operate as a constant air volume (CAV) unit in case of variable frequency drive (VFD) failure

Field Installed

Supply Static Limit Switch

- Manual reset switch for supply static high pressure limit
- Prevents exceeding pressure limit in supply air duct

Supply Static Pressure Limit Switch Mounting Kit

- Includes tubing and adaptors

FEATURES AND BENEFITS

CABINET

Construction

- Heavy-gauge steel panels and full perimeter steel base rail provides structural integrity for transportation, handling, and installation
- 6 • Base rails have rigging holes
- Raised edges around duct and power entry openings in the bottom of the unit for water protection

Power Entry

- Electrical lines can be routed through the unit base or through horizontal access knock-outs

Exterior Panels

- Constructed of heavy-gauge, galvanized steel
- Two-layer enamel paint finish

Insulation

- Fully insulated with non-hygroscopic fiberglass insulation (conditioned areas)
- Unit base is fully insulated
- Base insulation serves as an air seal to the roof curb, eliminating the need to add a seal during installation

7 **Access Panels**

- Stainless-steel hinges
- Panel seals and quarter-turn latching handles provide a tight air and water seal

Required Selections

Airflow Configuration

- Specify downflow or horizontal

Options/Accessories

Factory Installed

Corrosion Protection

- Completely flexible immersed coating
- Electrodeposited dry film process
- AST ElectroFin E-Coat
- ASTM B117 / DIN 53167 Salt Spray - 15,000+ hours
- ASTM G85 Annex A3 SWAAT Modified Salt Spray - 3000 hours
- VA Master Construction Specification Division 23 for High Humidity Installations
- CID AA-52474A (GSA)
- Indoor Corrosion Protection:
 - Coated coil
 - Coated reheat coil (Humiditrol®)
- Outdoor Corrosion Protection:
 - Coated coil

Double-Wall Construction

- Factory installed inner metal liner on all panels adjacent to conditioned air

Field Installed

Roof Curbs

- Downflow
- Nailer strip furnished
- Mates to unit
- Shipped knocked down
- US National Roofing Contractors Approved
- Available in 14 inch and 24 inch heights

NOTE - Also available - Roof curbs for vibration isolation, seismic conditions, seismic with wind restraints. Contact your Sales Representative for additional information.

FEATURES AND BENEFITS

ELECTRICAL

SmartWire™ System

- Keyed and color-coded wiring connectors prevent miswiring
- Wire coloring scheme is standardized across all models
- Each connection is intuitively labeled to make troubleshooting and servicing quick and easy

Electrical Plugs

- Positive connection electrical plugs are used to connect common accessories or maintenance parts for easy removal or installation

Required Selections

Voltage Choice

- Specify voltage when order base unit
 - 208/230V
 - 460V
 - 575V

Options/Accessories

Factory Installed

8 Electric Heat

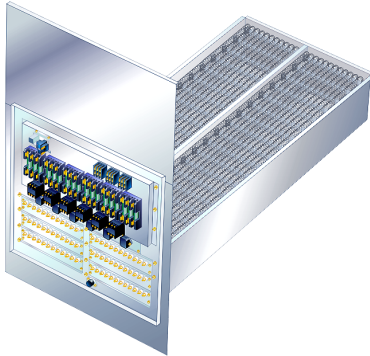

- Helix wound nichrome elements
- Time delay for element staging
- Individual element limit controls
- Wiring harness

NOTE - Electric Heat may be two-stage or four-stage controlled depending on unit controller settings.

Unit controller operating in thermostat control mode can achieve up to two-stage control.

The Unit Controller operating in zone sensor or thermostat mode with discharge air temperature control can achieve up to four-stage control.

NOTE - Electric Heat is not available with horizontal configured units.

NOTE - Electric heat with dual power supply requires field provided disconnects or HACR circuit breakers for both power supplies.

Circuit Breakers up to 250 Amp

- HACR circuit breaker
- Accessible from outside of unit
- Spring-loaded weatherproof cover furnished
- Main power to the unit is field connected to the circuit breaker which allows all power to be shutoff for service
- Circuit breaker is sized to the unit maximum overcurrent protection (MOCP) size

NOTE - Factory installed circuit breakers are not available for units with electric heat and dual point power supply. Circuit breakers must be field installed for these units.

Disconnect Switch up to 250 Amp

- Accessible from outside of unit
- Spring loaded weatherproof cover furnished
- Main power to the unit is field connected to the disconnect which allows all power to be shut off for service

NOTE - Factory installed disconnect switches are not available for units with electric heat and dual point power supply. Disconnect switches must be field installed for these units.

Factory or Field Installed

GFI Service Outlets (2)

- 115V ground fault circuit interrupter (GFCI) type options:
 - Factory installed and wired, unit powered
 - Factory installed, non-powered, field wired
 - Field installed, non-powered, field wired

Single-Point Power Supply

- Single power connection for unit

Field Installed

GFI Weatherproof Cover

- Single-gang cover
- Heavy-duty UV-resistant polycarbonate case construction
- Hinged base cover with gasket

CONTROL SYSTEM

PRODIGY® CONTROL SYSTEM



9 The Prodigy 2.0 unit controller is a microprocessor-based controller that provides flexible control of all unit functions.

Features:

- LCD Display
- Easy to read menu (4 lines x 20 character display)
- Buttons for menu navigation during setup and diagnostic
- Menu navigation LEDs for Data, Setup, Service, Settings
- Main Menu and Help Buttons for quick navigation to home screen and built-in help functions
- Scroll, Value Adjustment Select and Save Buttons
- Setup menu insures proper installation and simplified setup of the rooftop unit
- Profile setup copies key settings between units with the same configuration to reduce setup time
- USB port allows a technician to download and transfer unit information to help verify service was performed
- USB software updates on the Prodigy Control System enhance functionality without the need to change components
- Unit Controller Software
- Unit self-test verifies individual critical component and system performance
- Economizer test function assures economizer is operating correctly
- Time Clock with Run-Time Information

Built-In Functions Include:

- Adjustable Blower On/Off Delay
- Built-in Control Parameter Defaults
- Compressor Time-Off Delay
- DDC Compatible
- Dirty Filter Switch Input
- Discharge Air Temperature Control
- Display/Sensor Readout
- Economizer Control Options (See Economizer / Exhaust Air / Outdoor Air sections)
- Fresh Air Tempering
- Over 100 diagnostic and status messages in English
- Exhaust Fan Control Modes for fresh air damper position
- Permanent Diagnostic Code Storage
- Field Adjustable Control Parameters (Over 200 settings)
- Indoor Air Quality Input (Demand Control Ventilation)
- Low Ambient Controls for cooling operation down to 0°F
- Gas Valve Time Delay Between First and Second Stage

- Minimum Compressor Run Time
- Network Capable (Can be daisy chained to other units or controls)
- Night Setback Mode
- Return Air Temperature Limit Control
- Safety Switch Input allows Controller to respond to a external safety switch trip
- Service Relay Output
- Smoke Alarm Mode has four choices (unit off, positive pressure, negative pressure, purge)
- Up to 2 heat/2 cool (standard Prodigy unit controller thermostat input)
- Up to 3 cool with additional relay
- Up to 4 cool with room sensor or network operation
- "Strike Three" Protection
- Gas Reheat Control allows simultaneous heating and cooling operation for humidity control of process air applications such as supermarkets
- On Demand Dehumidification monitors and controls condenser hot gas reheat operation with Humiditrol® dehumidification option
- Thermostat Bounce Delay
- Warm Up Mode Delay
- LED Indicators
- PC Interface connects the Prodigy 2.0 unit controller to a PC with the Lennox Unit Controller Software
- Room Sensor Operation controls temperature

NOTE - Prodigy Control System features vary with the type of rooftop unit in which the control is installed.

NOTE - See separate Prodigy Control System Product Specifications Bulletin for additional information.

CONTROL SYSTEM

PRODIGY® CONTROL SYSTEM (continued)

Controls Options

Factory or Field Installed

Fresh Air Tempering

- Used in applications with high outside air requirements
- Controller energizes the first stage heat as needed to maintain a minimum supply air temperature for comfort, regardless of the thermostat demand
- When ordered as a factory option, sensor ships with the unit for field installation

Smoke Detector

- Photoelectric type
- Installed in supply air section, return air section or both sections
- Available with power board and single sensor (supply or return) or power board and two sensors (supply and return)
- Power board located in unit control compartment

Interoperability via BACnet® or LonTalk® Protocols

- Communication compatible with third-party automation systems that support the BACnet Application Specific Controller device profile, LonMark® Space Comfort Controller functional profile, or LonMark Discharge Air Controller functional profile

L Connection® Network Control System

- Complete building automation control system for single or multi-zone applications
- Options include local interface, software for local or remote communication, and hardware for networking other control functions
- See L Connection Network Control System Product Specifications Bulletin for details

Commercial Control Systems

Thermostats

- Control system and thermostat options, see page 14
- Aftermarket unit controller options

Field Installed

General Purpose Control Kit

- Plug-in control provides additional analog and digital inputs/outputs for field installed options

Humidity Sensor Kit

- Humidity sensor required with factory installed Humiditrol® dehumidification option or Supermarket reheat field selectable option

ECONOMIZER

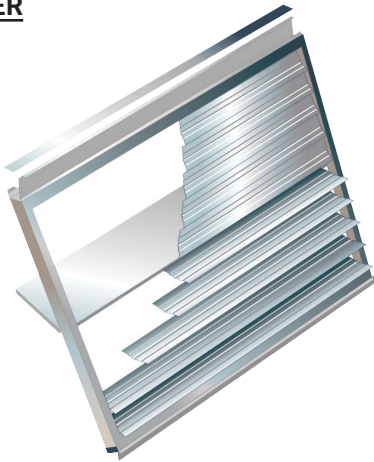

- Economizer operation is set and controlled by the Prodigy® 2.0 unit controller
- Simple plug-in connections from economizer to unit controller for easy installation
- All Emergence rooftop units are equipped with factory installed CEC Title 24 approved sensors for outside, return and discharge air temperature monitoring

NOTE - Optional sensors may be used instead of unit sensors to determine whether outdoor air is suitable for free cooling. See Options/Accessories table

Factory Installed

10 High Performance Economizer

- Approved for California Title 24 building standards
- Low leakage dampers are Air Movement and Control Association International (AMCA) Class 1A Certified - Maximum 3 CFM per sq. ft. leakage at 1 in. w.g.
- ASHRAE 90.1 compliant
- IECC compliant
- Gear-driven action
- High torque, 24-volt, fully-modulating spring return damper motor
- Return air and outdoor air dampers
- Plug-in connections to unit
- Stainless steel bearings
- Enhanced neoprene blade edge seals
- Flexible stainless steel jamb seals

NOTE - High Performance Economizers are not approved for use with enthalpy controls in Title 24 applications.

NOTE - The Free Cooling setpoint for Title 24 applications must be set based on the Climate Zone where the system is installed. See Section 140.4 "Prescriptive Requirements for Space Conditioning Systems" of the California Energy Commission's 2013 Building Energy Efficiency Standards.

NOTE: The Free Cooling default setting for outdoor air temperature sensor is 55°F.

NOTE - Refer to Installation Instructions for complete setup information.

Factory Installed

Emergence® Packaged Electric / Electric 35 to 50 Ton / Page 10

Differential Sensible Control

- Factory setting uses outdoor air and return air sensors that are furnished with the unit
- The Prodigy® 2.0 unit controller compares outdoor air and return air and using setpoints
- Enables the economizer when the outdoor air temperature is below the configured setpoint and cooler than return air

NOTE - Differential Sensible Control can be configured in the field to provide Offset Differential Sensible Control or Single Sensible Control.

In Offset Differential Sensible Control mode, the economizer is enabled if the temperature differential (offset) between outdoor air and return air reaches the configured setpoint.

In Single Sensible Control mode, the economizer is enabled when outdoor air temperature falls below the configured setpoint.

Global Control

- The unit controller communicates with a DDC system with one global sensor (enthalpy or sensible)
- Determines whether outside air is suitable for free cooling on all units connected to the control system

NOTE - Sensor must be field provided.

Single Enthalpy Temperature Control (Not for Title 24)

- Outdoor air enthalpy sensor enables Economizer if the outdoor enthalpy is less than the setpoint of the control

Differential Enthalpy Control (Not for Title 24)

- Two solid-state enthalpy sensors allow the economizer control board to select between outdoor air or return air, whichever has lower enthalpy

Indoor Air Quality Input

- The unit controller is Demand Control Ventilation ready from the factory (optional field installed CO₂ sensor required)
- Two modes of operation are available: setpoint and proportional
 - Setpoint - Opens the economizer dampers to full position when CO₂ setpoint level is reached
 - Proportional - Opens the dampers at the first set point and gradually increases it as the CO₂ level increases until the second setpoint is reached

OPTIONS / ACCESSORIES

EXHAUST

Factory Installed

Barometric Relief Dampers with Hood

- Allows relief of excess air
- Aluminum blade dampers prevent blow back and outdoor air infiltration during off cycle
- Bird screen furnished
- Exhaust hood furnished for field installation

11 Power Exhaust (Standard Static)

- Choice of 50% (one motor) or 100% (two motors)
- Direct drive
- Fan is 26 in. diameter
- Four blade propeller type
- Fan motor is inherently

Power Exhaust (High Static)

- Choice of 50% (one motor) or 100% (two motors)
- Centrifugal-type power exhaust
- Motors are available in 3, 5, or 7.5 hp
- Overload protected
- Ball bearings
- Forward curved blades
- Blower wheel statically and dynamically balanced
- Belt drive motors with adjustable pulley for speed change
- Also available with VFD or VFD and Bypass

NOTE - When ordering units configured for horizontal air discharge with high static power exhaust, Lennox recommends modification to the return air duct section to allow access to the power exhaust components for servicing.

Power Exhaust Control Modes

- Fans are controlled by fresh air damper position, differential pressure transducer or optional field installed pressure switch(es)

Damper Position Control

- Unit controller controls exhaust fan based on economizer damper position
- In two fan operation, the fans are staged

Differential Pressure Transducer

- Differential pressure transducer compares atmospheric pressure to conditioned space static pressure for controlling exhaust fan
- Transducer is factory installed
- Furnished standard with VFD power exhaust

Options/Accessories

Factory Installed

Outdoor Air CFM Control

- Maintains constant outdoor air volume levels units with variable frequency drives on the supply fan and varying unit airflows
- Using information from a velocity sensor located in the units' outdoor air section, the Prodigy® 2.0 unit controller changes the economizer position to help minimize the effect of supply fan speed changes on outdoor air volume levels
- Setpoint for outdoor air volume is established by field testing

NOTE - Not available with Demand Control Ventilation (CO₂ Sensor).

Spring Isolation

(High Static Power Exhaust Only)

- Spring isolation (2-inch diameter springs) under blower frame
- Blocked for shipment to prevent movement

Field Installed

Pressure Switch

- One or two pressure switches can be used to measure the static pressure in the building and operate the power exhaust if the limit is reached

NOTE - Order two per unit.

OUTDOOR AIR

Factory Installed

Outdoor Air Dampers (Manual or Motorized)

- Linked mechanical dampers (0 to 100%) without return
- Outdoor air adjustable
- Motorized model features spring return damper motor with plug-in connection
- Minimum entering mixed air temperature in heating mode is 45°F with aluminized steel heat exchanger
- Maximum entering mixed air temperature in cooling mode is 100°F

INDOOR AIR QUALITY

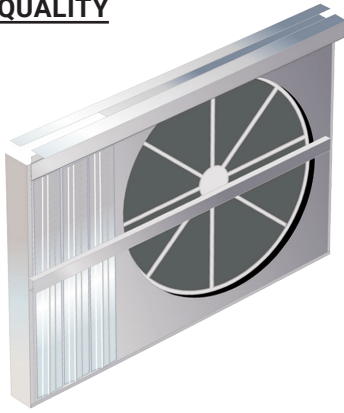

Factory Installed

12 Energy Recovery Wheel

NOTE - Not available with units configured for horizontal air flow.

- Helps reduce energy use and improve comfort and IAQ levels by conditioning outdoor air before it enters the building
- ERW enthalpy wheel contains several pie shaped sections with several layers of a desiccant coated polymeric energy transfer surface
- As the wheel rotates through the outdoor and exhaust air streams, it absorbs sensible and latent energy
- In heating mode, the wheel rotates to provides a constant transfer of heat from the exhaust air stream to the outdoor air intake air stream
- During cooling season, the process is reversed
- Sensible and latent energy are the two components of total energy
 - Sensible energy changes only the dry bulb temperature of a substance
 - Latent energy is not temperature, but the hidden (or 'latent') energy required to remove moisture from the air
- The ERW transfers moisture in the vapor phase so there are no condensate drains needed or wet surfaces to promote fungal growth
- As the ERW wheel rotates, air flow direction is reversed every 1/2 rotation keeping dirt and dust particles from accumulating on the wheel, which could cause poor performance
- Bypass dampers are included for economizer operation
- Frost control consists of a thermostat located in the exhaust air downstream of the ERW
- When low exhaust temperature indicates frost on the wheel, economizer outdoor air dampers close
- The wheel continues to rotate and the power exhaust fans continue to operate, pulling warm building air across the rotating wheel to defrost it
- When the defrost cycle is completed the economizer dampers return to the minimum outdoor air position
- Rated in accordance with AHRI Air-to-Air Energy Recovery Ventilation Equipment Certification Program, which is based on AHRI Standard 1060-2005

NOTE - To obtain a copy of the Standard or to view latest certified data, please visit the AHRI website at www.ahrinet.org.

HUMIDITROL® DEHUMIDIFICATION SYSTEM OPTION

OVERVIEW

NOTE - Only available for MSAV® (Multi-Stage Air Volume)

- Factory installed option designed to control humidity
- 13 • Provides dehumidification on demand using ASHRAE 90.1 recommended method for reheat with comfort conditioning humidity control
- A thermostat with a dehumidification output, a dehumidistat, or a DDC controller with an isolated output is required to control humidity and must be located in the occupied space
- Reheat controls are located in the compressor control section of the unit for easy access

Benefits

- Improves indoor air quality
- Helps prevent damage due to high humidity levels
- Improves comfort levels by reducing space humidity levels

OPERATION

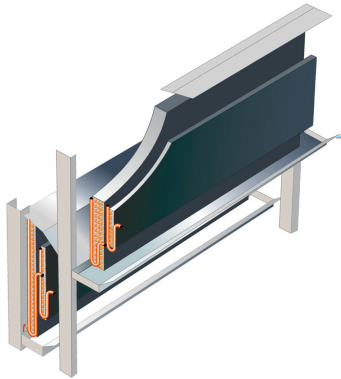

No Dehumidification Demand

- The unit will operate conventionally whenever there is a demand for cooling or heating and no dehumidification demand
- Free cooling is only permitted when there is no demand for dehumidification

Dehumidification and Cooling Demand (Room Sensor Application)

- If both a dehumidification demand and a first stage cooling demand occur, the system will operate compressor 1 and 2 in reheat and compressor 3 will operate in cooling
- If a demand for second stage cooling is initiated, compressor 1 and 2 will operate in reheat and compressor 3 and 4 will operate in cooling
- A demand for third stage cooling will terminate reheat and compressor 4 operation and operate compressor 1, 2 and 3 in cooling until third stage cooling demand is satisfied
- A demand for fourth stage cooling will operate compressor 1, 2, 3 and 4 in cooling

Dehumidification Demand Only

- Dehumidification is initiated by an output from a thermostat with a dehumidification output, a dehumidistat, or a DDC controller with an isolated output to control humidity
- Reheat operation will initiate on a dehumidification demand and does not require a cooling demand
- The unit will operate in the dehumidification mode until the relative humidity of the conditioned space is below the setpoint
- Reheat operation will initiate on a dehumidification demand and does not require a cooling demand
- The reheat coil is sized to offset most of the first stage sensible cooling effect during reheat only operation. This reduction in sensible cooling capacity extends compressor run time to control humidity when cooling loads are light
- Solenoid valves divert hot gas from compressor 1 and 2 to the reheat coil
- The cooled and dehumidified air from the evaporator is then reheated as it passes through the reheat coil
- The de-superheated and partially condensed refrigerant continues to the outdoor condenser coil where condensing is completed
- The unit will continue to operate in this mode until the dehumidification demand is satisfied
- A heating demand will terminate reheat operation

Options/Accessories

Field Installed

Humidity Sensor Kit

- Remote mounted dehumidistat for factory installed Humiditrol® option
- Adjustable 20-80%

NOTE - A thermostat with a dehumidification output or a DDC controller with an isolated output can be used instead.

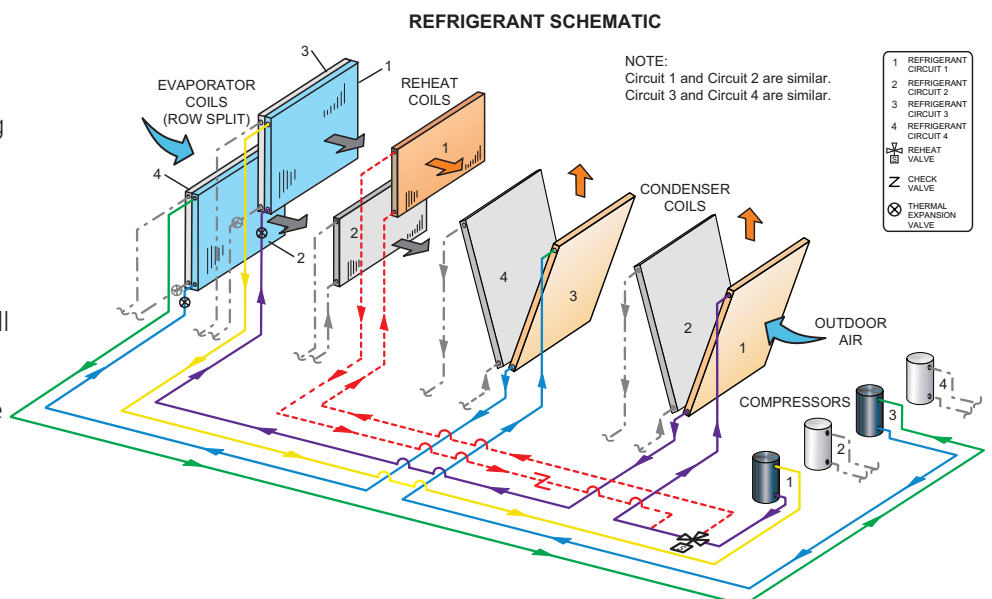

OPTIONAL CONVENTIONAL TEMPERATURE CONTROL SYSTEMS

CS8500 Commercial 7-Day Programmable Thermostat

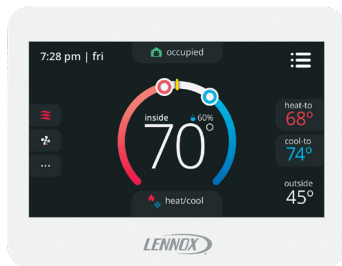

- Fully Communicating Sensor
- Full Color Touchscreen Interface
- Variable Speed System Control (On Compatible Units)
- Up To 4 Heat / 4 Cool
- Built-In Sensors For Temperature, Humidity And Optional CO₂
- Remote Sensor Options For Occupancy, Temperature
- BACnet Capable Options
- 5-2 or 7-Day Scheduling
- Smooth Setback Recovery
- Heat/Cool Auto-Changeover
- Four-Wire Installation
- FDD, ASHRAE, IECC Compliant

CS7500 Commercial 7-Day Programmable Thermostat



- Premium Universal Thermostat
- Full Color Touchscreen Interface
- Up To 4 Heat / 4 Cool
- Built-In Sensors For Temperature and Humidity
- Remote Sensors Options For Temperature, Discharge Air, Outdoor Air
- 5-2 or 7-Day Scheduling
- Smooth Setback Recovery
- Heat/Cool Auto-Changeover
- FDD, ASHRAE, IECC Compliant

CS3000 Commercial 5-2 Day Programmable Thermostat

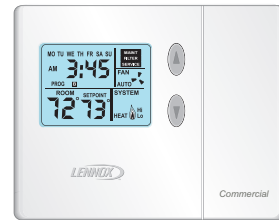

- Conventional Multi-Stage Thermostat
- Intuitive Display
- Push-Button Operation
- Up To 2 Heat / 2 Cool
- Built-In Temperature Sensor
- Remote Temperature Sensing
- Up to 5-2 Day Scheduling
- Smooth Setback Recovery
- Heat/Cool Auto-changeover

Wired Temperature/Humidity Room Sensor (LCS-5030)



- Simple Push-Button Override
- Variable Speed System Control (On Compatible Units)
- Up To 4 Heat / 4 Cool
- AA Battery / 24VAC Powered
- SBUS Wired Operation
- Automatic Sensor Averaging
- Locking Hex Screw

Wired Temperature/Humidity Room Sensor



- Terminal blocks for wiring connections
- Five-wire sensor connection
- Off-white plastic enclosure
- Non-adjustable
- Relative humidity range: 0 -100%
- +/- 3% Accuracy

OPTIONAL CONVENTIONAL TEMPERATURE CONTROL SYSTEMS

Description	Catalog No.
CS8500 Commercial 7 Day Programmable Thermostat	
CS8500 7-Day Thermostat	No CO ₂ Sensing 17G75
	With CO ₂ Sensing 17G76
Sensors/Accessories	¹ Remote non-adjustable wall-mount 10k 47W37
	¹ Remote non-adjustable wall-mount 11k 94L61
Sysbus Network Cable (Yellow) for ComfortSense 8500 and LCS-5030 Wired Room Sensor	
Twisted pair 100% shielded communication cable, Red and Black	500 ft. box 27M19
22 AWG, yellow jacket, rated at 75°C, 300V, Plenum rated	1000 ft. box 94L63
Insulation - Low smoke PVC, NEC, CMP	2500 ft. roll 68M25
CS7500 Commercial 7-Day Programmable Thermostat	
CS7500 7-Day Thermostat	17G74
Sensors/Accessories	² Remote non-adjustable wall-mount 20k 47W36
	² Remote non-adjustable wall-mount 10k 47W37
	Remote non-adjustable discharge air (duct mount) 19L22
	Outdoor temperature sensor X2658
CS3000 Commercial 5-2 Day Programmable Thermostat	
CS3000 5-2 Day Thermostat	11Y05
Sensors/Accessories	Remote non-adjustable wall mount 10k averaging 47W37
	Thermostat wall mounting plate X2659
Universal Thermostat Guard with Lock (clear)	
	Inside Dimensions (H x W) 5 7/8 x 8 3/8 in. 39P21
Temperature/Humidity Room Sensors	
LCS-5030 Wired Temperature/Humidity Room Sensor	21L07
A335MT13AE1 Wired Temperature/Humidity Room Sensor	21W06

¹ Up to nine of the same type remote temperature sensors can be connected in parallel.

² Remote wall-mount sensors can be applied in any of the following combinations:
 One Sensor - (1) 47W36, Two Sensors - (2) 47W37, Three Sensors - (2) 47W36 and (1) 47W37
 Four Sensors - (4) 47W36, Five Sensors - (3) 47W36 and (2) 47W37

SEQUENCE OF OPERATION

UNIT CONTROLLER CONTROL MODES

Unit Controller can operate in several different control modes. The selection of these control modes will depend upon several factors:

- Unit type - MSAV® (Multi-Stage Air Volume) or Variable Air Volume (VAV) with supply fan variable frequency drive.
- Zoning application (single zone, bypass zoning or zoning)
- Which device will control rooftop unit staging and unit operation (thermostat / third party unit controller or the Unit Controller)
- The desired level of unit heating and cooling staging (2 heat / 2 cool or 4 heat / 4 cool)

Unit Controller In Zone Sensor Mode

MSAV® (MULTI-STAGE AIR VOLUME) UNIT IN SINGLE ZONE APPLICATION

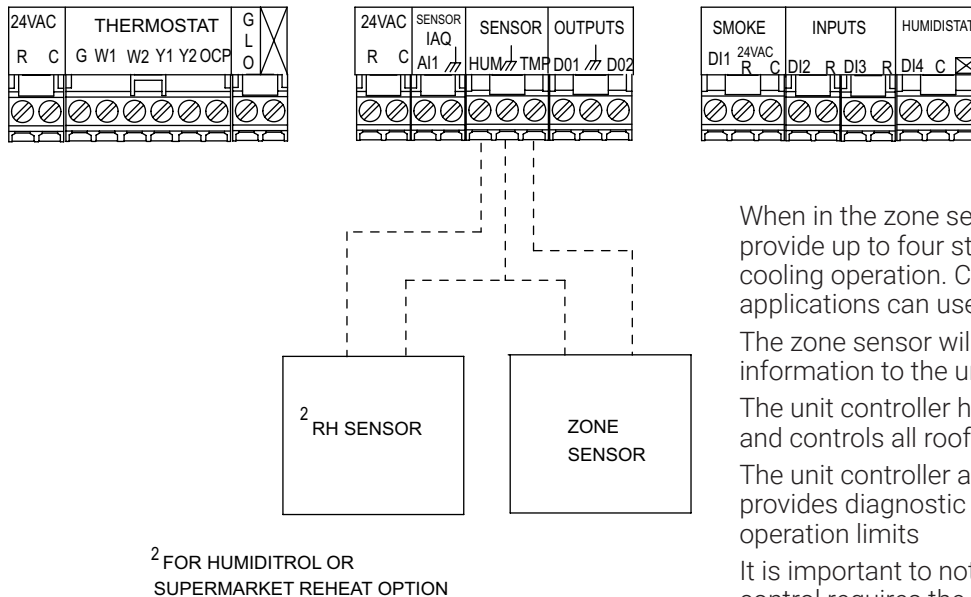

When in the zone sensor mode, the unit controller can provide up to four stages of mechanical heating and cooling operation. Constant volume units in single zone applications can use this control mode

The zone sensor will provide space temperature information to the unit controller

The unit controller houses all space temperature setpoints and controls all rooftop unit staging and general operation

The unit controller also determines unit error codes, provides diagnostic information and maintains safe operation limits

It is important to note that scheduling and/or setpoint control requires the use of one of the following control systems:

- Lennox S-Bus controlled system
- BACnet® Module (for Prodigy® 2.0 Unit Controller)
- LonTalk® Module (for Prodigy® 2.0 Unit Controller)
- Novar® LSE Unit Controller
- CPC Einstein Unit Controller

SEQUENCE OF OPERATION

UNIT CONTROLLER CONTROL MODES (continued)

Unit Controller In Thermostat Mode

When in the thermostat mode, the unit controller can provide up to two stages of mechanical heating and cooling operation

MSAV® (Multi-Stage Air Volume) units in either single zone or bypass zoning applications can use this control mode

To operate correctly, a Lennox or third-party thermostat or unit control must provide the following wiring connections to the unit controller:

- Ventilation demand
- Occupied demand
- Heating demand one
- Heating demand two
- Cooling demand one
- Cooling demand two

In this configuration, either the thermostat or unit control will control the rooftop unit staging and general operation. The unit controller functions primarily to determine unit error codes, provide diagnostic information and maintain safe operation limits.

MSAV® (MULTI-STAGE AIR VOLUME) UNIT IN SINGLE ZONE APPLICATION

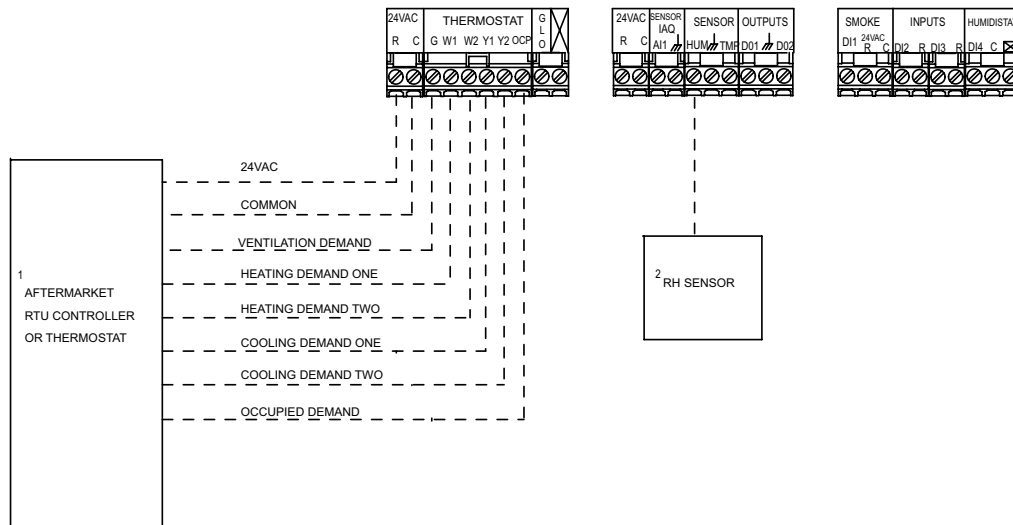

¹ SEE AFTERMARKET CONTROLLER INSTALLATION INSTRUCTION FOR WIRING INFORMATION.

² FOR HUMIDITROL OR SUPERMARKET REHEAT OPTION

MSAV® (MULTI-STAGE AIR VOLUME) UNIT IN BYPASS ZONING APPLICATION

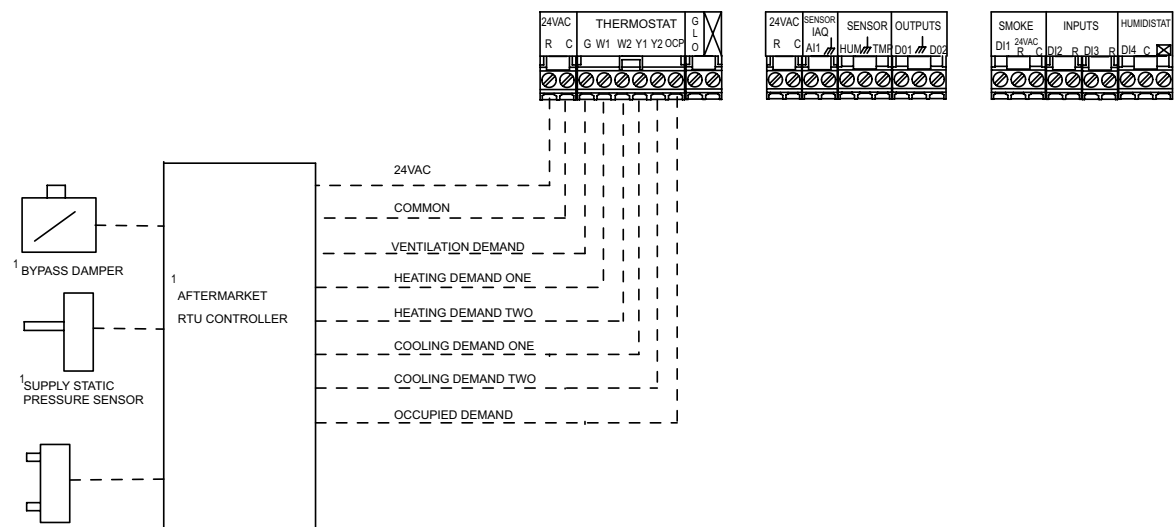

¹ OPTIONAL BUILDING STATIC PRESSURE SWITCH OR SENSOR

¹ SEE AFTERMARKET CONTROLLER INSTALLATION INSTRUCTION FOR WIRING INFORMATION.

SEQUENCE OF OPERATION

UNIT CONTROLLER CONTROL MODES (continued)

Unit Controller In Thermostat Mode

When in thermostat mode and configured for discharge air temperature control, the unit controller can provide up to four stages of mechanical heating and cooling operation

Variable air volume units using a variable frequency drive on the supply fan and operating in a zoning application must use this control mode. Although not as common, MSAV® (Multi-Stage Air Volume) in either single zone or bypass zoning applications may also use this control mode

To operate correctly, a Lennox or third-party thermostat or unit control must provide the following wiring connections to the unit controller:

- Ventilation demand
- Occupied demand
- Heating demand
- Cooling demand

In this control mode the unit controller will control all cooling and heating staging to maintain the discharge air temperature setpoints set in the unit controller (typically 55°F for cooling and 110°F for heating)

A third-party unit control, or a thermostat can provide these inputs to the unit controller. For example, if the unit control passes along a demand for cooling then the unit controller will activate the refrigeration system and increase or decrease cooling stages to maintain the discharge supply air temperature setpoint. In this mode (VAV units only), the unit controller will also maintain the supply duct static pressure by directly controlling the supply fan variable frequency drive

Along with providing control of the rooftop unit, the unit controller will also provide error codes and diagnostic information

VARIABLE AIR VOLUME UNIT IN ZONING APPLICATION

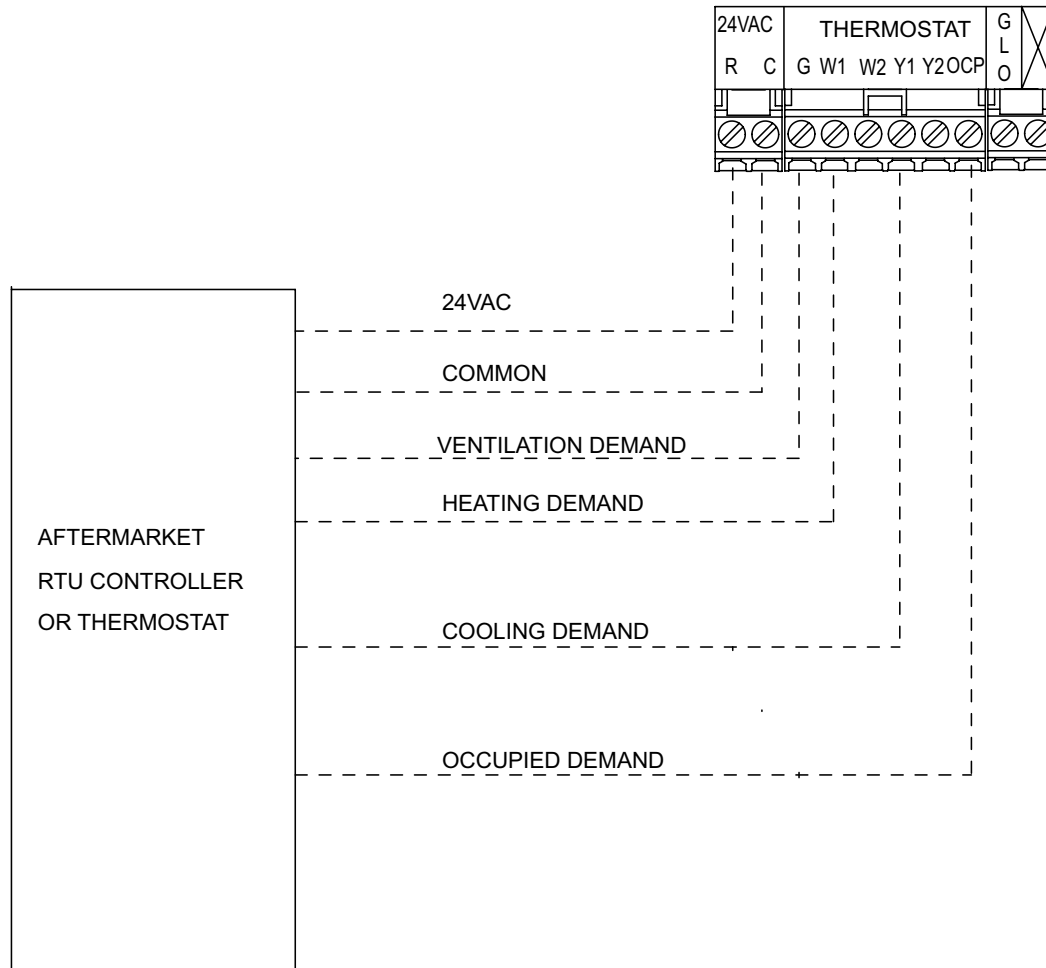

SEQUENCE OF OPERATION

OPERATIONS COMMON TO ALL ROOFTOP UNITS

The following sequence of operation information applies to all Emergence® rooftop units regardless of unit controller control mode, unit type or zoning application.

Heating operation (modulating gas)

The Emergence® unit features two separate gas burner sections, each with a modulating gas valve and a shut-off valve. The modulating gas heat section can provide continuous operation from 25-100% of total heat capacity.

Upon receiving a heating demand, the unit controller will instruct the modulating gas unit to maintain a discharge air temperature setpoint (default 110°F). The unit maintains this setpoint by feeding information from a discharge air temperature sensor located in the supply duct back to the unit controller. Based on this information, the unit controller increases or decreases gas heat output to maintain the desired heating setpoint.

The unit controller controls modulation by adjusting either one or both of the gas burner sections. Upon receiving a heating demand, the unit controller will bring on both gas burner sections at 100%. When the discharge air temperature reaches the setpoint (default 110°F), the unit controller will modulate both gas burner sections by the same amount between 100% and 50% to maintain the setpoint. If less heat is required to maintain the setpoint, the unit controller will turn off the second gas burner section and modulate the first gas burner section between 100% and 50% (50% to 25% of total unit capacity).

The basic operation of modulating gas remains the same regardless of unit type or unit controller mode.

Gas heat modulation requires the necessary mechanical components, a discharge air temperature sensor located in the supply duct and a single heating demand to the unit controller.

Occupied Demand

Upon receiving occupied and ventilation demands from the Lennox or third party unit controller, the unit controller adjusts the fresh air damper to either a fixed minimum position or allows it to modulate based on a CO₂ sensor (demand control ventilation). The CO₂ sensor can be wired directly to the unit controller, to another controller that can monitor the sensor and pass a signal to the unit controller for damper control, or to both the unit controller and another device for monitoring through the desired man-machine interface while the unit controller maintains damper control.

During morning warm-up the unit controller keeps the fresh air damper closed based on unit controller configuration settings. Setpoints for minimum and maximum damper position and CO₂ control reside in the unit controller memory, have factory default settings, and may be adjusted at start up. The user can change these settings either locally or remotely through Lennox' L Connection Network® Unit Controller Software. The user will not have the ability to adjust the settings through third party software or control devices.

Demand Control Ventilation

Demand control ventilation is used in applications where the demand for fresh outdoor air fluctuates during the occupied time period. Using a CO₂ sensor connected directly to the unit controller, the unit can intelligently increase or decrease the amount of fresh outdoor air by changing the outdoor air damper position. The unit

controller has two operation modes available, setpoint or proportional, to control the outdoor air damper position.

Fresh Air Tempering (FAT)

In applications with large outdoor air requirements, Fresh Air Tempering is used to minimize temperature fluctuations in the conditioned space. The unit controller controls discharge air temperature by energizing heating or cooling in response to the discharge supply air duct temperature. Fresh air tempering only occurs when there is no heating or cooling demand from the occupied space. The user must configure the unit controller to turn on the fresh air tempering option.

Heating is energized when discharge air temperature falls below fresh air heating setpoint (60°F default) and terminates when the return air temperature is less than the setpoint. Cooling is energized when discharge air temperature rises above fresh air cooling setpoint (80°F default) and terminates when the return air temperature is greater than the setpoint. FAT will operate up to four stages of heating and cooling to maintain discharge air temperature. Standard heating and cooling demands will override FAT heating and cooling demands.

Hot Gas Bypass

By selecting the hot gas bypass option, the unit can operate in low airflow applications down to 12.5% of nominal capacity. As the suction line pressure decreases and the potential for coil frosting increases, the mechanical system bypasses hot refrigerant gas from the first stage compressor discharge line back to the suction line. The hot gas increases the pressure of the suction line and reduces the compressor capacity. A de-superheater valve bypasses refrigerant from the liquid line and mixes it with the hot gas before entering the suction line to maintain the setpoint suction gas superheat entering the compressor.

Discharge Air Cooling Reset Operation

Discharge air cooling reset operation saves energy by gradually increasing the discharge air setpoint as outside air temperature decreases. This operation also reduces the potential for overcooling if the zoning system is misapplied, has an abnormal condition, or has a dominant zone. The unit controller has various advanced discharge air cooling reset options which can be selected at start up and are based on either return air temperature, outside air temperature, or both return and outdoor air temperature.

Discharge Air Heating Reset Operation

Discharge air heating reset operation saves energy by gradually decreasing the discharge air setpoint as outside air temperature increases. This operation reduces the potential for overheating if the zoning system is misapplied, has an abnormal condition, or has a dominant zone. The unit controller has various advanced discharge air heating reset options which can be selected at start up and are based on either return air temperature, outside air temperature or both return and outdoor air temperature.

SEQUENCE OF OPERATION

MSAV® (MULTI-STAGE AIR VOLUME) UNITS IN SINGLE ZONE APPLICATIONS WITH A LENNOX ZONE SENSOR (4 Heat / 4 Cool)

Unit Controller Operation

When using a Lennox zone sensor with the unit controller operating in zone sensor mode, a packaged rooftop unit can provide up to four stages each of mechanical heating and cooling operation. The zone sensor provides space temperature information to the unit controller. The unit controller houses all space temperature setpoints and controls all rooftop unit staging and general operation functions. The unit controller also determines unit error codes, provides diagnostic information and maintains safe operation limits.

Ventilation Demand

When the unit controller is in zone sensor control mode, the user has several different ventilation sequence of operation scenarios to choose from. The default mode causes the unit controller to activate the supply fan when both a ventilation and either heating or cooling demand are present. This occurs independent of receiving an occupied demand. The user can change the default setting to allow the supply fan to run continuously when the unit controller receives both a ventilation and occupied demand. This is independent of a call for either heating or cooling. When the unit controller receives a ventilation demand and occupied demand is not present, the unit controller will only activate the supply fan when it receives either a heating or cooling demand.

Cooling Demand

The unit controller directly monitors space temperature through the zone sensor. Based on this information, the unit controller activates the different compressor stages to maintain the desired occupied space temperature setpoint. Increasing compressor stages provides more cooling capacity while decreasing compressor stages provides less cooling capacity. The unit controller has direct control over the rooftop unit mechanical cooling staging operation. The user has the option to configure the unit controller so that if the zone sensor fails, the unit controller can use a backup operation to control unit operation.

Energence® units feature four separate compressors and refrigeration circuits that can provide up to four stages of mechanical cooling operation. For stage one operation, the unit controller activates the first compressor (25% of total unit capacity). For stage two operation, the unit controller activates the second compressor (50% unit capacity). For stage three operation, the unit controller activates the third compressor (75% total unit capacity). For stage four operation, the unit controller activates the fourth compressor (100% unit capacity). Depending on the zone sensor configuration setting, occupants in the space can change the setpoint. The unit controller automatically recognizes this change and instructs the unit to respond accordingly.

Cooling Demand With Economizer

If the outdoor air is suitable for free cooling and the unit has an economizer, the unit controller will open the economizer and use fresh air for stage one cooling. For stage two cooling operation, the unit controller activates the first compressor. For stage three cooling operation, the unit controller activates the second compressor. For stage four cooling operation, the unit controller activates the remaining compressors (number three and four). The unit controller has direct control over the rooftop unit mechanical cooling staging and economizer operation.

Heating Demand (General Operation)

The unit controller directly monitors space temperature through the zone sensor. Based on this information, the unit controller turns on or off the heating stages to maintain the desired temperature setpoint. Increasing heating stages provides additional heating capacity while decreasing heating stages provides less heating capacity. The unit controller has direct control over rooftop unit mechanical heating staging operation. Energence® units feature four separate heating stages that can provide up to four stages of mechanical heating operation. The specific heating capacity varies for each stage depending on the heat source. Depending on the zone sensor configuration setting, occupants in the space can change the setpoint. The unit controller automatically recognizes this change and instructs the unit to respond accordingly.

Heating Demand (Electric)

Energence® units feature multiple electric heat sections available in sizes from 30 kW to 180 kW (depending on unit size and voltage). Units can provide up to four stages of mechanical heating depending on the size of the electric heater. Staged operation occurs similar to cooling operation, with the unit controller activating or deactivating sections of the electric heater to maintain the discharge air temperature setpoint.

SEQUENCE OF OPERATION

MSAV® (MULTI-STAGE AIR VOLUME) UNITS IN SINGLE ZONE APPLICATIONS WITH A LENNOX ZONE SENSOR (4 Heat / 4 Cool) (continued)

Humiditrol® Dehumidification Operation - Dehumidification Demand

Upon a dehumidification only demand, the unit controller activates compressors number one and two and sets the indoor blower to the slowest available speed. At the same time, the unit controller uses solenoid valves to divert hot gas from compressors one and two to the first reheat coil. The cooled and dehumidified air from the evaporator is then reheated as it passes through the reheat coil. The de-superheated and partially condensed refrigerant continues to the outdoor condenser coil where condensing is completed.

The reheat coil is sized to offset most of the first and second stages of sensible cooling effect during reheat only operation. This reduction in sensible cooling capacity extends compressor run time to control humidity when cooling loads are light. The unit continues to operate in this mode until the dehumidification demand is satisfied. A heating demand terminates reheat operation.

The unit controller relative humidity setpoint is set at the factory for 60% and can be adjusted at the unit controller or with the L Connection® Network Unit Controller Software. For Network Control Panel (NCP) applications, the humidity setpoint can be adjusted at the NCP. The unit controller also has an option for an external digital input for the dehumidification demand. This demand must be provided from an external third party unit controller.

Humiditrol® Dehumidification Operation - Cooling Demand Only

The unit will operate conventionally whenever there is a demand for cooling and no dehumidification demand. The unit can provide up to four stages of mechanical cooling in this scenario. Free cooling is only permitted when an economizer is present, there is no demand for dehumidification and the outdoor air is suitable for this function.

Humiditrol® Dehumidification Operation - Cooling And Dehumidification Demand

When a cooling demand is present with a dehumidifying demand and the blower is set to maximum speed:

- **Stage One** - Cooling demand with dehumidification demand: If both a dehumidification demand and a first stage cooling demand occur, the system activates the first three compressors plus both reheat valves. This provides approximately 75% humidity removal capacity plus 25% cooling capacity.
- **Stage Two** - Cooling demand with dehumidification demand: A demand for second stage cooling plus dehumidification activates all four compressors plus both reheat valves. This provides 100% humidity removal capacity plus approximately 50% cooling capacity.
- **Stage Three** - Cooling demand with dehumidification demand: A demand for stage three cooling plus dehumidification activates all three compressors plus one reheat valve. This provides 100% humidity removal capacity and 75% cooling capacity.
- **Stage Four** - Cooling demand with dehumidification demand: A demand for stage four cooling plus dehumidification activates all four compressors and no reheat valves. This will provide 100% humidity removal capacity and 100% cooling capacity.

SEQUENCE OF OPERATION

MSAV® (MULTI-STAGE AIR VOLUME) UNITS IN SINGLE ZONE APPLICATIONS WITH A THERMOSTAT OR THIRD PARTY UNIT CONTROLLER (2 Heat / 2 Cool)

Unit Controller Operation

When using a two-stage heat/cool thermostat or third party unit controller with the unit controller in the thermostat mode, a packaged rooftop unit can provide up to two stages of mechanical heating and cooling operation.

To operate correctly, a thermostat or third party unit controller must provide the following wiring connections to the unit controller:

- Ventilation demand
- Occupied demand
- Heating demand one
- Heating demand two
- Cooling demand one
- Cooling demand two

In this set up, either the thermostat or third party unit controller controls the rooftop unit staging and general operation. The unit controller functions primarily to determine unit error codes, provide diagnostic information and maintain safe operation limits.

Ventilation Demand

Upon receiving a ventilation demand from the thermostat or third party unit controller, the unit controller instructs the supply fan to start operation. The supply fan runs at full capacity as long as a ventilation demand is present.

Cooling Demand

Upon receiving a stage one demand for cooling from the thermostat or third party unit controller, the unit controller activates the first two compressors, providing 50% cooling capacity.

If the unit is unable to satisfy the call for cooling within a specified time period and receives a stage two cooling demand from the thermostat or third party unit controller, the unit controller activates the third and fourth compressors, providing 100% cooling capacity. The thermostat or third party unit controller has direct control over the rooftop unit's staging capability.

Cooling Demand With Economizer

If the unit features an economizer and outdoor air is suitable for free cooling, a call for stage one cooling will activate the economizer. The unit will try to satisfy the cooling demand using outdoor air rather than mechanical cooling.

If the unit is unable to satisfy the call for cooling within a specified time period using the economizer and receives a stage two call for cooling from the thermostat or third party unit controller, the unit controller activates all four compressors. This will provide 100% cooling capacity. It is important to note that the thermostat or third party unit controller has direct control over the rooftop unit's staging capability. While the unit controller typically has direct control over the economizer, it is possible for a thermostat or third party unit controller to directly control this functionality.

Heating Demand (General Operation)

Upon receiving a stage one heating demand from the thermostat or third party unit controller, the unit controller activates the unit's heating section to start operation. This activates the first two stages of mechanical heat, providing approximately 66% heating capacity.

If the unit is unable to satisfy the call for heating within a specified time period and receives a stage two heating demand from the thermostat or third party controller, the unit controller activates the third and fourth stages of heat, providing 100% heating capacity. It is important to note that the thermostat or third party unit controller has direct control over the rooftop unit's staging capability.

Heating Demand (Electric)

Units feature multiple electric heat sections available in sizes from 30 kW to 180 kW (depending on unit size and voltage). Units can provide up to two stages of mechanical heating depending on the size of the electric heater.

Staged operation occurs similar to cooling operation, with the thermostat or third party unit controller activating or deactivating sections of the electric heater as the demand for heat increases or decreases.

Humiditrol® Dehumidification Operation - Dehumidification Demand

Upon a dehumidification demand, the unit controller activates compressor number one and two. At the same time, the unit controller uses solenoid valves to divert hot gas from compressor one and two to the first reheat coil. The cooled and dehumidified air from the evaporator is then reheated as it passes through the reheat coil. The de-superheated and partially condensed refrigerant continues to the outdoor condenser coil where condensing is completed. The reheat coil is sized to offset most of the first and second stages of sensible cooling effect during reheat only operation. This reduction in sensible cooling capacity extends compressor run time to control humidity when cooling loads are light.

The unit will continue to operate in this mode until the dehumidification demand is satisfied. A heating demand will terminate reheat operation.

The unit controller relative humidity setpoint is factory configured for 60% and can be adjusted at the unit controller or with the L Connection Network Unit Controller software. For Network Control Panel (NCP) applications, the humidity setpoint can be adjusted at the NCP. The unit controller also has an option for an external digital input to signal the dehumidification demand. This demand must be provided from an external third party DDC.

SEQUENCE OF OPERATION

MSAV® (MULTI-STAGE AIR VOLUME) UNITS IN SINGLE ZONE APPLICATIONS WITH A THERMOSTAT OR THIRD PARTY UNIT CONTROLLER (2 Heat / 2 Cool) (continued)

Humiditrol® Dehumidification Operation - Cooling Demand

The unit operates conventionally whenever there is a demand for cooling and no dehumidification demand. The unit can provide up to two stages of mechanical cooling in this scenario. Free cooling is only permitted when an economizer is present, there is no demand for dehumidification and outdoor air is suitable for this function.

Humiditrol® Dehumidification Operation - Cooling And Dehumidification Demand

Stage one cooling demand with dehumidification demand: If both a dehumidification demand and a first stage cooling demand occur, the system activates all four compressors plus both reheat valves. This provides 100% humidity removal capacity with approximately 50% cooling capacity.

- Stage two cooling demand with dehumidification demand: A demand for second stage cooling activates all four compressors plus terminates any reheat operation. This provides 100% humidity removal capability and 100% cooling capacity. The unit controller activates all compressors until the cooling demand is satisfied.

SEQUENCE OF OPERATION

MSAV® (MULTI-STAGE AIR VOLUME) UNITS IN SINGLE ZONE APPLICATIONS WITH A THERMOSTAT OR THIRD PARTY UNIT CONTROLLER AND THE UNIT OPERATING IN DISCHARGE AIR TEMPERATURE CONTROL (4 Heat / 4 Cool)

Unit Controller Operation

When using a thermostat or third party unit controller with the unit controller operating in the thermostat mode configured for discharge air temperature control, a packaged rooftop unit can provide up to four stages of mechanical heating and cooling operation.

To operate correctly, a thermostat or third party controller must provide the following wiring connections to the unit controller:

- Ventilation demand
- Occupied demand
- Heating demand
- Cooling demand

In this configuration the unit controller will control the rooftop staging and general operation. The thermostat or third party unit controller only informs the unit controller if there is a specific demand. For example, if the thermostat or third party unit controller passes along a demand for cooling, the controller increases or decreases cooling stages to maintain the discharge supply air temperature setpoint. Along with providing control of the rooftop unit, the unit controller also provides error codes, diagnostic information and maintains safe operating limits.

Ventilation Demand

Upon receiving a ventilation demand from the thermostat or unit controller, the unit controller activates the supply fan. The supply fan operates at 100% capacity until the ventilation demand has been removed.

Cooling Demand

Upon receiving a cooling demand from the thermostat or unit controller, the unit controller instructs the unit to maintain a cooling discharge air temperature setpoint. The unit controller has direct control over the rooftop unit staging. The discharge supply air temperature setpoint resides in the unit controller, has a factory default setting, and can be adjusted at start-up. The user can adjust the setpoint either locally or remotely with Lennox' L Connection® Network Unit Controller software or at the unit controller board. The user can not adjust the setpoint through a third party control device or software program.

The unit controller receives discharge supply air temperature information directly from the temperature sensor, located in the supply duct system. Based on this information, the unit controller activates the different compressor stages to maintain the discharge supply air temperature setpoint (55°F default). Increasing compressor stages provides more cooling capacity while decreasing compressor stages provides less cooling capacity.

Energence® units feature four separate compressors and refrigeration circuits that can provide up to four stages of mechanical cooling operation:

- **Stage One Operation** - Unit controller activates the first compressor (25% of total unit capacity)
- **Stage Two Operation** - Unit controller activates the second compressor (50% unit capacity)
- **Stage Three Operation** - Unit controller activates the third compressor (75% total unit capacity)
- **Stage Four Operation** - Unit controller activates the fourth compressor (100% unit capacity)

Cooling Demand With Economizer

If outdoor air is suitable for free cooling and the unit has an economizer

- **Stage One Operation** - Unit controller opens the economizer and uses fresh air
- **Stage Two Operation** - Unit controller activates one compressor
- **Stage Three Operation** - Unit controller activates a second compressor
- **Stage Four Operation** - Unit controller activates the remaining compressors (number three and four)

The unit controller has direct control over the rooftop unit staging and economizer operation.

Heating Demand (General Operation)

Upon receiving a heating demand from a thermostat or a third party controller, the unit controller instructs the unit to maintain a heating discharge air temperature setpoint. The unit controller has direct control over the rooftop unit heating staging operation. The unit controller receives discharge supply air temperature information directly from the temperature sensor located in the supply duct. Based on this information, the unit controller activates the different heating stages to maintain the discharge supply air temperature setpoint (110°F default). Turning on additional heating stages increases the heating capacity, while turning off heating stages decreases the heating capacity. The heating discharge air temperature setpoint resides in the unit controller, has a factory default setting, and may be adjusted at start up. The user can adjust the setpoint either locally or remotely with Lennox' L Connection Network Unit Controller software or at the unit controller board. The user can not adjust the setpoint through a third party control device or software program.

Heating Operation (Electric)

Energence® units feature multiple electric heat sections available in sizes from 30 kW to 180 kW (depending on unit size and voltage). Units can provide up to four stages of mechanical heating depending on the size of the electric heater. Staged operation occurs similar to cooling operation, with the unit controller activating or deactivating sections of the electric heater to maintain the discharge air temperature setpoint.

SEQUENCE OF OPERATION

MSAV® (MULTI-STAGE AIR VOLUME) UNITS IN BYPASS ZONING APPLICATIONS WITH A THERMOSTAT OR THIRD PARTY UNIT CONTROLLER (2 Heat / 2 Cool)

Unit Controller Operation

When using a third-party unit controller and the unit controller is operating in the thermostat mode, a packaged rooftop unit can provide up to two stages of mechanical heating and cooling operation.

To operate correctly, a unit controller must provide the following wiring connections to the unit controller:

- Ventilation demand
- Occupied demand
- Heating demand one
- Heating demand two
- Cooling demand one
- Cooling demand two

In this configuration the third party unit controller will control the rooftop unit staging and general operation. The unit controller functions primarily to determine unit error codes, provide diagnostic information and maintain safe operating limits.

Unit Sequence Of Operation

MSAV units in bypass zoning applications featuring a Lennox or third party unit controller with the unit controller operating in thermostat mode, have the same basic heating and cooling unit sequence of operations as MSAV units in single zone applications featuring a third party unit controller, with the unit controller operating in thermostat mode.

For specific information, refer to the MSAV® (Multi-Stage Air Volume) units in bypass zoning applications with a thermostat or third party unit controller section.

The following sequence of operation information is specific to MSAV units in bypass zoning applications.

Supply Duct Bypass Damper

To maintain accurate supply duct static pressure control, MSAV units in bypass zoning applications use a bypass damper between the supply and return air ducts. In this scenario, the supply duct static pressure transducer and damper connect directly to the third party unit controller. Based on actual static pressure relative to setpoint, the third party unit controller either modulates open or closes the damper. If the damper modulates further closed, the static pressure in the supply air duct increases. If the damper modulates further open, the static pressure in the supply air duct decreases. The unit controller does not have direct control over the bypass damper in this scenario.

SEQUENCE OF OPERATION

MSAV® (MULTI-STAGE AIR VOLUME) UNITS IN BYPASS ZONING APPLICATIONS WITH A THIRD PARTY UNIT CONTROLLER AND THE UNIT OPERATING IN DISCHARGE AIR TEMPERATURE CONTROL (4 Heat / 4 Cool)

Unit Controller Operation

When using a third party unit controller and the unit controller is operating in thermostat mode and configured for discharge air temperature control, a packaged rooftop unit can provide up to four stages of mechanical heating and cooling operation. To operate correctly, a third party unit controller must provide the following wiring connections to the unit controller:

- Ventilation demand
- Occupied demand
- Heating demand
- Cooling demand

In this configuration, the unit controller controls the rooftop staging and general operation. The third party unit controller only informs the unit controller as to whether or not there is a specific demand. For example, if the third party unit controller passes along a demand for cooling, then the unit controller increases or decreases cooling stages to maintain the discharge supply air temperature setpoint. Along with controlling the rooftop unit, the unit controller also determines error codes, provides diagnostic information and maintains safe operating limits.

Unit Sequence Of Operation

MSAV units in bypass zoning applications featuring a third party unit controller with the unit controller operating in thermostat mode, configured for discharge air temperature control have the same basic heating and cooling unit sequence of operations as MSAV units in single zone applications featuring a third party unit controller, with the unit controller operating in thermostat mode with discharge air temperature control.

NOTE - For specific unit sequence of operation information refer to the MSAV® (Multi-Stage Air Volume) units in Single Zone Applications with a Thermostat or Third Party Unit Controller and the Unit Operating in Discharge Air Temperature Control section.

The following sequence of operation information is specific to MSAV units in bypass zoning applications.

Supply Duct Bypass Damper

To maintain accurate supply duct static pressure control, MSAV units in bypass zoning applications typically feature a bypass damper between the supply and return air ducts. In this scenario, the supply duct static pressure transducer and damper connect directly to the third party unit controller. Based on actual static pressure relative to setpoint, the unit controller either modulates open or modulates closed the bypass damper.

If the damper modulates further closed, the static pressure in the supply air duct increases. If the damper modulates further open, the static pressure in the supply air duct decreases. The unit controller does not have any direct control over the bypass damper in this scenario.

SEQUENCE OF OPERATION

VARIABLE AIR VOLUME (VAV) UNITS IN ZONING APPLICATIONS WITH A THIRD PARTY UNIT CONTROLLER AND THE UNIT OPERATING IN DISCHARGE AIR TEMPERATURE CONTROL (4 Heat / 4 Cool)

Unit Controller Operation

When using a third party unit controller with the unit controller operating in thermostat mode configured for discharge air temperature control, a packaged rooftop unit can provide up to four stages of mechanical heating and cooling operation. To operate correctly, a third party unit controller must provide the following wiring connections to the unit controller:

- Ventilation demand
- Occupied demand
- Heating demand
- Cooling demand

In this configuration, the unit controller controls the rooftop unit staging and general operation. The third party unit controller only informs the unit controller as to whether or not there is a specific demand. For example, if the unit controller passes along a demand for cooling, then the unit controller increases or decreases cooling stages to maintain the discharge supply air temperature setpoint. In this mode, the unit controller also maintains the supply duct static pressure by directly controlling the supply fan variable frequency drive. Along with providing control of the rooftop unit, the unit controller determines error codes, supplies diagnostic information and maintains safe operating limits.

Ventilation Demand

Upon receiving a ventilation demand from the unit controller, the unit controller instructs the supply fan variable frequency drive to start the supply fan and maintain a constant supply duct static pressure setpoint. The unit controller has direct control over the variable frequency drive and supply fan.

The unit controller receives supply duct static pressure information directly from a supply duct static pressure sensor located approximately three quarters down the length of the longest main supply duct. Based on information from the supply duct static pressure transducer relative to setpoint, the unit controller instructs the variable frequency drive to either increase or decrease the speed of the supply fan. Speeding up the supply fan will increase the supply duct static pressure while slowing down the supply fan speed will decrease the supply duct static pressure. For increased flexibility, the unit controller has separate, adjustable static pressure setpoints for ventilation, cooling, heating and smoke alarms. These set points reside in the unit controller memory, have factory default settings and may be adjusted in the field prior to start-up.

Cooling Demand

Upon receiving a cooling demand from the unit controller, the unit controller instructs the unit to maintain a cooling discharge air temperature setpoint. The unit controller has direct control over the rooftop unit staging. The unit controller receives discharge supply air temperature information directly from the supply duct temperature sensor located in the supply duct system. Based on this information, the unit controller turns on or off the different compressor stages to maintain the discharge

supply air temperature setpoint (55°F default). Increasing compressor stages provides more cooling capacity while decreasing compressor stages provides less cooling capacity.

Energence® units feature four separate compressor and refrigeration circuits that can provide up to four stages of mechanical cooling operation:

- **Stage One Operation** - Unit controller activates the first compressor (25% of total unit capacity)
- **Stage Two Operation** - Unit controller activates the second compressor (50% unit capacity)
- **Stage Three Operation** - Unit controller activates the third compressor (75% total unit capacity)
- **Stage Four Operation** - Unit controller activates the fourth compressor (100% unit capacity)

The discharge supply air temperature setpoint resides in the unit controller, has a factory default setting, and can be adjusted at start-up. The user can adjust the setpoint either locally or remotely with the L Connection® Network Unit Controller software or at the unit controller board. The user cannot adjust the setpoint through a third party control device or software program.

Cooling Demand With Economizer

If outdoor air is suitable for free cooling and the unit has an economizer:

- **Stage One Operation** - Unit controller opens the economizer and uses fresh air
- **Stage Two Operation** - Unit controller activates one compressor
- **Stage Three Operation** - Unit controller activates a second compressor
- **Stage Four Operation** - Unit controller activates the remaining compressors (number three and four).

The unit controller has direct control over the rooftop unit staging and economizer operation.

Heating Demand (general operation)

- Upon receiving a heating demand from the third party unit controller, the unit controller instructs the unit to maintain a heating discharge air temperature setpoint. The unit controller has direct control over the rooftop unit heating staging operation. The unit controller receives discharge supply air temperature information directly from the supply duct temperature sensor located in the supply duct system. Based on this information, the unit controller turns on or off mechanical heating stages to maintain the discharge supply air temperature setpoint (110°F default). Adding heat stages increases heat capacity while removing heat stages decreases heat capacity.
- The heating discharge air temperature set point resides in the unit controller, has a factory default setting, and may be adjusted at start up. The user can adjust the setpoint either locally or remotely with the L Connection® Network Unit Controller software. The user cannot adjust the setpoint through a third party control device or software program.

SEQUENCE OF OPERATION

VARIABLE AIR VOLUME (VAV) UNITS IN ZONING APPLICATIONS WITH A THIRD PARTY UNIT CONTROLLER AND THE UNIT OPERATING IN DISCHARGE AIR TEMPERATURE CONTROL (4 Heat / 4 Cool) (continued)

Heating Operation (Electric)

Energence® units feature multiple electric heat sections available in sizes from 30 kW to 180 kW (depending on unit size and voltage). Units can provide up to four stages of mechanical heating depending on the size of the electric heater. Staged operation occurs similar to cooling operation, with the unit controller activating or deactivating sections of the electric heater to maintain the discharge air temperature setpoint.

Morning Warm Up

Energence® units have an intelligent and innovative morning warm up control scheme. As the VAV system shifts from unoccupied to occupied, the unit controller automatically keeps the economizer shut for 60 minutes (default) or until the first cooling demand. On cold days this prevents unconditioned fresh outdoor air from entering the building and helps to reduce energy usage. Because most VAV systems perform morning warm up before occupants enter the building, the absence of fresh outdoor air typically does not cause any problems.

Upon the first call for heating in this scenario, the unit controller instructs the unit to turn on the heating section and start supply fan operation. Because the unit controller controls the heat staging and supply fan operation based on actual discharge supply air temperature control and supply duct static pressure, the rooftop unit automatically selects the proper staging and supply fan speed to ensure optimal performance.

Typically in this scenario all zones are below the desired room temperature setpoint so the VAV boxes will be fully open. This causes the supply duct static pressure to be low so the unit controller speeds up the fan to maintain the supply duct static pressure setpoint. As the supply fan speeds up and increases the total supply air volume, the heating section turns on additional stages to maintain the correct discharge supply air temperature setpoint. In the event the unit controller receives a call for cooling from the third party unit controller, the unit controller switches to cooling mode and opens the economizer. This intelligent control scheme helps prevent potential problems caused by stuck VAV box dampers and supply duct static over pressurization.

Outdoor Air CFM Control

The Outdoor Air CFM Control option allows variable air volume units to minimize the effect of supply fan speed changes and maintain a constant outdoor air CFM level. A sensor located in the outdoor air section of the unit measures the outdoor air velocity and relays the information to the unit controller. Based on the velocity information, the unit controller automatically adjusts the economizer position, offsetting the supply fan speed changes and maintaining a constant outdoor air CFM level.

OPTIONS / ACCESSORIES

Item	Factory	Field	
COOLING SYSTEM			
Corrosion Protection - Condenser and Evaporator Coils	O		
Discharge Air Temperature Sensor (MSAV models only)	O		
Drain Pan Overflow Switch	O		
High Efficiency - R-410A (35, 40 Ton Models)	O		
Hot Gas Bypass (Not available with Humiditrol® Dehumidification Option)	O		
Standard Efficiency - R-410A (35, 40, 45, 50 Ton Models)	O		
Service Valves	O		
Spring Isolation (compressor deck)	O		
Stainless Steel Drain Pan	O		
AIR FILTERS			
MERV 8 - Two Inch	O		
MERV 8 - Four Inch	O		
MERV 13 High Efficiency - Two Inch	O		
MERV 13 High Efficiency - Four Inch	O		
Cleanable Metal Mesh - Two Inch	O		
BLOWER			
Supply Motor - 5, 7.5, 10, 15, 20, 25, 30 hp	O		
Supply VFD Blower Bypass	O		
Spring Isolation (blower frame)	O		
CABINET			
Air Flow - Vertical	O		
Air Flow - Horizontal	O		
Double Wall Construction	O		
Hinged Louvered Condenser Section Panels	O		
¹ ROOF CURBS - STANDARD			
14 in. height	11F67	X	
24 in. height	11F69	X	
CONTROLS			
Blower Proving Switch	O		
Commercial Controls	Prodigy® Control System - BACnet® Module - 59W51	O X	
	Prodigy® Control System - LonTalk® Module - 54W27	O X	
	Novar® LSE Unit Controller	O	
	CPC Einstein Unit Controller	O	
	L Connection® Network Control System		X
Dirty Filter Switch	53W68	O X	
General Purpose Control Kit	13J79		X
Supply Static Pressure Limit Switch - Duct Mounted	Switch - 79M80		X
	Mounting Kit - 79M81		X
Smoke Detector	Return	O	
	Supply	O	
	Supply & Return	O	
ELECTRICAL			
Voltage (60HZ) - 208/230V-3 phase, 460V-3 phase or 575V-3 phase	O		
HACR Circuit Breakers - 70, 80, 90, 100, 110, 125, 150, 175, 200, 225, 250 amp Not available for units with electric heat and dual point power supply	O		
Disconnect Switch - 150, 250 amp Not available for units with electric heat and dual point power supply	O		
GFI Service Outlets	15 amp non-powered, field-wired (208/230V, 460V, 575V) 74M70	O	X
	15 amp factory-wired and powered (208/230V, 460V, 575V)	O	
	20 amp non-powered, field-wired (575V only) 67E01	O	X
Weatherproof Cover for GFI	10C89		X

¹ Also available - Roof curbs for vibration isolation, seismic conditions, seismic with wind restraints. Contact your Sales Representative for additional information.

O = Configure to Order (Factory Installed).

X = Field Installed.

OPTIONS / ACCESSORIES

Item	Factory	Field
ELECTRIC HEAT (NOT AVAILABLE WITH HORIZONTAL CONFIGURED UNITS)		
35 ton units - 30-45-60-75-90 kW (all voltages)	O	
35 ton units - 105-120 kW (460V & 575V only)	O	
40 ton units - 30-45-60-75-90 kW (all voltages)	O	
40 ton units - 105-120-135-150 kW (460V & 575V only)	O	
45 ton units - 45-60-75-90 kW (all voltages)	O	
45 ton units - 105-120-135-150-165 kW (460V & 575V only)	O	
50 ton units - 45-60-75-90 kW (all voltages)	O	
50 ton units - 105-120-135-150-165-180 kW (460V & 575V only)	O	
Single-Point Power Supply	O	
HUMIDITROL® DEHUMIDIFICATION CONDENSER REHEAT (MSAV UNITS ONLY)		
Humiditrol® Dehumidification Option	O	
Humidity Sensor Kit, Remote Mounted (required)	17M50	X
INDOOR AIR QUALITY		
Sensor - Wall-mount, off-white plastic cover with LCD display	77N39	X
Sensor - Wall-mount, off-white plastic cover, no display	23V86	X
Sensor - Black plastic case with LCD display, rated for plenum mounting	87N52	X
Sensor - Wall-mount, black plastic case, no display, rated for plenum mounting	87N54	X
CO ₂ Sensor Duct Mounting Kit - for downflow applications	85L43	X
Aspiration Box - for duct mounting non-plenum rated CO ₂ (77N39) sensors	90N43	X
ECONOMIZER/OUTDOOR AIR/EXHAUST		
High Performance Economizer (Approved for California Title 24 Building Standards / AMCA Class 1A Certified)	O	
Economizer Controls		
Differential Sensible (factory setting)	O	
Global Control	O	
Single Enthalpy (Not for Title 24)	O	
Differential Enthalpy (Not for Title 24)	O	
Fresh Air Tempering	O	
Outdoor Air CFM Control	O	
Outdoor Air Dampers		
Manual	O	
Motorized	O	
Barometric Relief Dampers (Exhaust Hood Furnished for Field Installation)		
Barometric Relief Dampers with Exhaust Hood	O	
POWER EXHAUST (see next page for specifications)		
50% Standard Static	O	
100% Standard Static	O	
50% High Static Power Exhaust	O	
100% High Static Power Exhaust	O	
50% High Static Power Exhaust with VFD	O	
100% High Static Power Exhaust with VFD	O	
50% High Static Power Exhaust with VFD and Bypass	O	
100% High Static Power Exhaust with VFD and Bypass	O	
Power Exhaust Controls		
Damper Position Control	O	
¹ Differential Pressure Transducer	O	
Pressure Switch (order two)	79M79	X
High Static Power Exhaust Options		
Spring Isolation (blower frame)	O	
INDOOR AIR QUALITY		
Energy Recovery Wheel (not available with horizontal configured units)	O	

¹ Furnished as standard with High Static Power Exhaust with VFD.

O = Configure to Order (Factory Installed).

X = Field Installed.

SPECIFICATIONS - OPTIONAL POWER EXHAUST

Standard Static (50%)	(No.) Motor output	(1) 1 hp
	Motor rpm	1140
	(No.) Diameter - in.	(1) 26
	No. of blades	4
Standard Static (100%)	(No.) Motor output	(2) 1 hp
	Motor rpm	1140
	(No.) Diameter - in.	(2) 26
	No. of blades	4
High Static (50%)	(No.) Nominal motor output	(1) 3, 5 or 7.5 hp available See Blower Data Tables for selection
	Motor - Drive Kit	690 to 1065 rpm available See Blower Drive Kit Tables for selection
	(No.) Blower wheel nominal diameter x width	(1) 18 x 15
	(No.) Nominal motor output	(2) 3, 5 or 7.5 hp available See Blower Data Tables for selection
High Static (100%)	Motor - Drive Kit	690 to 1065 rpm available See Blower Drive Kit Tables for selection
	(No.) Blower wheel nominal diameter x width	(2) 18 x 15

SPECIFICATIONS - 35 TON STANDARD EFFICIENCY

General Data		Nominal Tonnage	35 Ton	35 Ton	
		Model No.	LCH420S4M	LCH420S4V	
		Efficiency Type	Standard	Standard	
		Blower Type	MSAV® (Multi-Stage Air Volume)	Variable Air Volume (VAV)	
Cooling Performance	Gross Cooling Capacity - Btuh		433,000	433,000	
	¹ Net Cooling Capacity - Btuh		410,000	410,000	
	AHRI Rated Air Flow - cfm		14,000	14,000	
	Total Unit Power - kW		41.0	41.0	
	¹ EER (Btuh/Watt)		10.0	10.0	
	² IEER (Btuh/Watt)		13.5	13.2	
	Refrigerant Type		R-410A	R-410A	
	Refrigerant Charge Furnished	Circuit 1	Circuit 1	22 lbs. 0 oz.	22 lbs. 0 oz.
			Circuit 2	22 lbs. 0 oz.	22 lbs. 0 oz.
			Circuit 3	22 lbs. 0 oz.	22 lbs. 0 oz.
Circuit 4			22 lbs. 0 oz.	22 lbs. 0 oz.	
Refrigerant Charge Furnished with Humiditrol® Dehumidification Option		Circuit 1	Circuit 1	27 lbs. 0 oz.	---
			Circuit 2	27 lbs. 0 oz.	---
			Circuit 3	22 lbs. 0 oz.	---
			Circuit 4	22 lbs. 0 oz.	---
Compressor Type (no.)		Scroll (4)	Scroll (4)		
Condenser Coils	Net face area - sq. ft. total		94.1	94.1	
	Tube diameter - in.		3/8	3/8	
	Number of rows		2	2	
	Fins per inch		20	20	
Condenser Fans	Motor horsepower		(6) 3/4	(6) 3/4	
	Motor rpm		1075	1075	
	Total Motor watts		4800	4800	
	Diameter - in.		(6) 24	(6) 24	
	No. of blades		4	4	
	Total Air volume - cfm		30,000	30,000	
Evaporator Coils	Net face area - sq. ft. total		37.4	37.4	
	Tube diameter - in.		3/8	3/8	
	No. of rows		4	4	
	Fins per inch		14	14	
	Drain connection - number and size		(1) 1 in. NPT coupling	(1) 1 in. NPT coupling	
Expansion device type		Balanced Port Thermostatic Expansion Valve, removeable power head			
Indoor Blower and Drive Selection	Nominal motor output		5 to 30 hp available - See Blower Data Tables for selection		
	Motor - Drive kit		510 to 1340 rpm available - See Blower Drive Kit Tables for selection	510 to 1340 rpm available - See Blower Drive Kit Tables for selection	
	Blower wheel nominal dia. x width - in.		(2) 20 x 15	(2) 20 x 15	
Filters	Type of filter		Disposable, pleated MERV 4		
	No. and size - in.		(11) 25 x 16 x 2		
Electrical characteristics		208/230V, 460V or 575V - 60 hertz - 3 phase			

NOTE - Net capacity includes evaporator blower motor heat deduction. Gross capacity does not include evaporator blower motor heat deduction.

¹ Tested at conditions included in AHRI Standard 340/360; 95°F outdoor air temperature and 80°F db/67°F wb entering evaporator air; minimum external duct static pressure.

² Integrated Energy Efficiency Ratio tested according to AHRI Standard 340/360.

SPECIFICATIONS - 35 TON HIGH EFFICIENCY

General Data		Nominal Tonnage	35 Ton	35 Ton	
		Model No.	LCH420H4M	LCH420H4V	
		Efficiency Type	High	High	
		Blower Type	MSAV® (Multi-Stage Air Volume)	Variable Air Volume (VAV)	
Cooling Performance	Gross Cooling Capacity - Btuh		443,000	443,000	
	¹ Net Cooling Capacity - Btuh		420,000	420,000	
	AHRI Rated Air Flow - cfm		14,000	14,000	
	Total Unit Power - kW		38.9	38.9	
	¹ EER (Btuh/Watt)		10.8	10.8	
	² IEER (Btuh/Watt)		14.5	14.0	
	Refrigerant Type		R-410A	R-410A	
	Refrigerant Charge Furnished	Circuit 1		31 lbs. 0 oz.	31 lbs. 0 oz.
		Circuit 2		31 lbs. 0 oz.	31 lbs. 0 oz.
		Circuit 3		31 lbs. 0 oz.	31 lbs. 0 oz.
Circuit 4			31 lbs. 0 oz.	31 lbs. 0 oz.	
Refrigerant Charge Furnished with Humiditrol® Dehumidification Option	Circuit 1		36 lbs. 0 oz.	---	
	Circuit 2		36 lbs. 0 oz.	---	
	Circuit 3		31 lbs. 0 oz.	---	
	Circuit 4		31 lbs. 0 oz.	---	
Compressor Type (no.)			Scroll (4)	Scroll (4)	
Condenser Coils	Net face area - sq. ft. total		111.2	111.2	
	Tube diameter - in.		3/8	3/8	
	Number of rows		3	3	
	Fins per inch		20	20	
Condenser Fans	Motor horsepower		(6) 1	(6) 1	
	Motor rpm		1140	1140	
	Total Motor watts		5000	5000	
	Diameter - in.		(6) 24	(6) 24	
	No. of blades		4	4	
	Total Air volume - cfm		35,000	35,000	
Evaporator Coils	Net face area - sq. ft. total		37.4	37.4	
	Tube diameter - in.		3/8	3/8	
	No. of rows		4	4	
	Fins per inch		14	14	
	Drain connection - number and size		(1) 1 in. NPT coupling	(1) 1 in. NPT coupling	
Expansion device type			Balanced Port Thermostatic Expansion Valve, removeable power head		
Indoor Blower and Drive Selection	Nominal motor output		5 to 30 hp available - See Blower Data Tables for selection		
	Motor - Drive kit		510 to 1340 rpm available - See Blower Drive Kit Tables for selection	510 to 1340 rpm available - See Blower Drive Kit Tables for selection	
	Blower wheel nominal dia. x width - in.		(2) 20 x 15	(2) 20 x 15	
Filters	Type of filter		Disposable, pleated MERV 4		
	No. and size - in.		(11) 25 x 16 x 2		
Electrical characteristics			208/230V, 460V or 575V - 60 hertz - 3 phase		

NOTE - Net capacity includes evaporator blower motor heat deduction. Gross capacity does not include evaporator blower motor heat deduction.

¹ Tested at conditions included in AHRI Standard 340/360; 95°F outdoor air temperature and 80°F db/67°F wb entering evaporator air; minimum external duct static pressure.

² Integrated Energy Efficiency Ratio tested according to AHRI Standard 340/360.

SPECIFICATIONS - 40 TON STANDARD EFFICIENCY

General Data		Nominal Tonnage	40 Ton	40 Ton
		Model No.	LCH480S4M	LCH480S4V
		Efficiency Type	Standard	Standard
		Blower Type	MSAV® (Multi-Stage Air Volume)	Variable Air Volume (VAV)
Cooling Performance	Gross Cooling Capacity - Btuh		476,000	476,000
	¹ Net Cooling Capacity - Btuh		450,000	450,000
	AHRI Rated Air Flow - cfm		14,800	14,800
	Total Unit Power - kW		45.0	45
	¹ EER (Btuh/Watt)		10.0	10.0
	² IEER (Btuh/Watt)		13.5	13.2
	Refrigerant Type		R-410A	R-410A
	Refrigerant Charge Furnished		Circuit 1	22 lbs. 0 oz.
Circuit 2			22 lbs. 0 oz.	22 lbs . 0 oz.
Circuit 3			22 lbs. 0 oz.	22 lbs . 0 oz.
Circuit 4			22 lbs. 0 oz.	22 lbs . 0 oz.
Refrigerant Charge Furnished with Humiditrol® Dehumidification Option		Circuit 1	27 lbs. 0 oz.	---
		Circuit 2	27 lbs. 0 oz.	---
		Circuit 3	22 lbs. 0 oz.	---
		Circuit 4	22 lbs. 0 oz.	---
Compressor Type (no.)			Scroll (4)	Scroll (4)
Condenser Coils	Net face area - sq. ft. total		94.1	94.1
	Tube diameter - in.		3/8	3/8
	Number of rows		2	2
	Fins per inch		20	20
Condenser Fans	Motor horsepower		(6) 3/4	(6) 3/4
	Motor rpm		1075	1075
	Total Motor watts		4800	4800
	Diameter - in.		(6) 24	(6) 24
	No. of blades		4	4
	Total Air volume - cfm		30,000	30,000
Evaporator Coils	Net face area - sq. ft. total		37.4	37.4
	Tube diameter - in.		3/8	3/8
	No. of rows		4	4
	Fins per inch		14	14
	Drain connection - number and size		(1) 1 in. NPT coupling	(1) 1 in. NPT coupling
Expansion device type		Balanced Port Thermostatic Expansion Valve, removeable power head		
Indoor Blower and Drive Selection	Nominal motor output		5 to 30 hp available - See Blower Data Tables for selection	
	Motor - Drive kit		510 to 1340 rpm available - See Blower Drive Kit Tables for selection	510 to 1340 rpm available - See Blower Drive Kit Tables for selection
	Blower wheel nominal dia. x width - in.		(2) 20 x 15	(2) 20 x 15
Filters	Type of filter		Disposable, pleated MERV 4	
	No. and size - in.		(11) 25 x 16 x 2	
Electrical characteristics		208/230V, 460V or 575V - 60 hertz - 3 phase		

NOTE - Net capacity includes evaporator blower motor heat deduction. Gross capacity does not include evaporator blower motor heat deduction.

¹ Tested at conditions included in AHRI Standard 340/360; 95°F outdoor air temperature and 80°F db/67°F wb entering evaporator air; minimum external duct static pressure.

² Integrated Energy Efficiency Ratio tested according to AHRI Standard 340/360.

SPECIFICATIONS - 40 TON HIGH EFFICIENCY

General Data	Nominal Tonnage	40 Ton	40 Ton	
	Model No.	LCH480H4M	LCH480H4V	
	Efficiency Type	High	High	
	Blower Type	MSAV® (Multi-Stage Air Volume)	Variable Air Volume (VAV)	
Cooling Performance	Gross Cooling Capacity - Btuh	494,000	494,000	
	¹ Net Cooling Capacity - Btuh	470,000	470,000	
	AHRI Rated Air Flow - cfm	14,000	14,000	
	Total Unit Power - kW	43.5	43.5	
	¹ EER (Btuh/Watt)	10.8	10.8	
	² IEER (Btuh/Watt)	14.5	14.0	
	Refrigerant Type	R-410A	R-410A	
	Refrigerant Charge Furnished	Circuit 1	31 lbs. 0 oz.	31 lbs. 0 oz.
		Circuit 2	31 lbs. 0 oz.	31 lbs. 0 oz.
		Circuit 3	31 lbs. 0 oz.	31 lbs. 0 oz.
Circuit 4		31 lbs. 0 oz.	31 lbs. 0 oz.	
Refrigerant Charge Furnished with Humiditrol® Dehumidification Option	Circuit 1	36 lbs. 0 oz.	---	
	Circuit 2	36 lbs. 0 oz.	---	
	Circuit 3	31 lbs. 0 oz.	---	
	Circuit 4	31 lbs. 0 oz.	---	
Compressor Type (no.)		Scroll (4)	Scroll (4)	
Condenser Coils	Net face area - sq. ft. total	111.2	111.2	
	Tube diameter - in.	3/8	3/8	
	Number of rows	3	3	
	Fins per inch	20	20	
Condenser Fans	Motor horsepower	(6) 1	(6) 1	
	Motor rpm	1140	1140	
	Total Motor watts	5000	5000	
	Diameter - in.	(6) 24	(6) 24	
	No. of blades	4	4	
	Total Air volume - cfm	35,000	35,000	
Evaporator Coils	Net face area - sq. ft. total	37.4	37.4	
	Tube diameter - in.	3/8	3/8	
	No. of rows	4	4	
	Fins per inch	14	14	
	Drain connection - number and size	(1) 1 in. NPT coupling	(1) 1 in. NPT coupling	
	Expansion device type	Balanced Port Thermostatic Expansion Valve, removeable power head		
Indoor Blower and Drive Selection	Nominal motor output	5 to 30 hp available - See Blower Data Tables for selection		
	Motor - Drive kit	510 to 1340 rpm available - See Blower Drive Kit Tables for selection	510 to 1340 rpm available - See Blower Drive Kit Tables for selection	
	Blower wheel nominal dia. x width - in.	(2) 20 x 15	(2) 20 x 15	
Filters	Type of filter	Disposable, pleated MERV 4		
	No. and size - in.	(11) 25 x 16 x 2		
Electrical characteristics		208/230V, 460V or 575V - 60 hertz - 3 phase		

NOTE - Net capacity includes evaporator blower motor heat deduction. Gross capacity does not include evaporator blower motor heat deduction.

¹ Tested at conditions included in AHRI Standard 340/360; 95°F outdoor air temperature and 80°F db/67°F wb entering evaporator air; minimum external duct static pressure.

² Integrated Energy Efficiency Ratio tested according to AHRI Standard 340/360.

SPECIFICATIONS - 45 TON STANDARD EFFICIENCY

General Data		Nominal Tonnage	45 Ton	45 Ton	
		Model No.	LCH540S4M	LCH540S4V	
		Efficiency Type	Standard	Standard	
		Blower Type	MSAV® (Multi-Stage Air Volume)	Variable Air Volume (VAV)	
Cooling Performance	Gross Cooling Capacity - Btuh		549,000	549,000	
	¹ Net Cooling Capacity - Btuh		520,000	520,000	
	AHRI Rated Air Flow - cfm		15,000	15,000	
	Total Unit Power - kW		52.0	52.0	
	¹ EER (Btuh/Watt)		10.0	10.0	
	² IEER (Btuh/Watt)		13.7	13.6	
	Refrigerant Type		R-410A	R-410A	
	Refrigerant Charge Furnished	Circuit 1		31 lbs. 0 oz.	31 lbs. 0 oz.
		Circuit 2		31 lbs. 0 oz.	31 lbs. 0 oz.
		Circuit 3		31 lbs. 0 oz.	31 lbs. 0 oz.
Circuit 4			31 lbs. 0 oz.	31 lbs. 0 oz.	
Refrigerant Charge Furnished with Humiditrol® Dehumidification Option	Circuit 1		36 lbs. 0 oz.	---	
	Circuit 2		36 lbs. 0 oz.	---	
	Circuit 3		31 lbs. 0 oz.	---	
	Circuit 4		31 lbs. 0 oz.	---	
Compressor Type (no.)			Scroll (4)	Scroll (4)	
Condenser Coils	Net face area - sq. ft. total		111.2	111.2	
	Tube diameter - in.		3/8	3/8	
	Number of rows		3	3	
	Fins per inch		20	20	
Condenser Fans	Motor horsepower		(6) 3/4	(6) 3/4	
	Motor rpm		1075	1075	
	Total Motor watts		4900	4900	
	Diameter - in.		(6) 24	(6) 24	
	No. of blades		4	4	
	Total Air volume - cfm		29,000	29,000	
Evaporator Coils	Net face area - sq. ft. total		37.4	37.4	
	Tube diameter - in.		3/8	3/8	
	No. of rows		4	4	
	Fins per inch		14	14	
	Drain connection - number and size		(1) 1 in. NPT coupling	(1) 1 in. NPT coupling	
Expansion device type			Balanced Port Thermostatic Expansion Valve, removeable power head		
Indoor Blower and Drive Selection	Nominal motor output		5 to 30 hp available - See Blower Data Tables for selection		
	Motor - Drive kit		510 to 1340 rpm available - See Blower Drive Kit Tables for selection	510 to 1340 rpm available - See Blower Drive Kit Tables for selection	
	Blower wheel nominal dia. x width - in.		(2) 20 x 15	(2) 20 x 15	
Filters	Type of filter		Disposable, pleated MERV 4		
	No. and size - in.		(11) 25 x 16 x 2		
Electrical characteristics			208/230V, 460V or 575V - 60 hertz - 3 phase		

NOTE - Net capacity includes evaporator blower motor heat deduction. Gross capacity does not include evaporator blower motor heat deduction.

¹ Tested at conditions included in AHRI Standard 340/360; 95°F outdoor air temperature and 80°F db/67°F wb entering evaporator air; minimum external duct static pressure.

² Integrated Energy Efficiency Ratio tested according to AHRI Standard 340/360.

SPECIFICATIONS - 50 TON STANDARD EFFICIENCY

General Data		Nominal Tonnage	50 Ton	50 Ton	
		Model No.	LCH600S4M	LCH600S4V	
		Efficiency Type	Standard	Standard	
		Blower Type	MSAV® (Multi-Stage Air Volume)	Variable Air Volume (VAV)	
Cooling Performance	Gross Cooling Capacity - Btuh		598,000	598,000	
	¹ Net Cooling Capacity - Btuh		565,000	565,000	
	AHRI Rated Air Flow - cfm		16,000	16,000	
	Total Unit Power - kW		56.5	56.5	
	¹ EER (Btuh/Watt)		10.0	10.0	
	² IEER (Btuh/Watt)		13.5	13.2	
	Refrigerant Type		R-410A	R-410A	
	Refrigerant Charge Furnished	Circuit 1		31 lbs. 0 oz.	31 lbs. 0 oz.
		Circuit 2		31 lbs. 0 oz.	31 lbs. 0 oz.
		Circuit 3		31 lbs. 0 oz.	31 lbs. 0 oz.
Circuit 4			31 lbs. 0 oz.	31 lbs. 0 oz.	
Refrigerant Charge Furnished with Humiditrol® Dehumidification Option	Circuit 1		36 lbs. 0 oz.	---	
	Circuit 2		36 lbs. 0 oz.	---	
	Circuit 3		31 lbs. 0 oz.	---	
	Circuit 4		31 lbs. 0 oz.	---	
Compressor Type (no.)			Scroll (4)	Scroll (4)	
Condenser Coils	Net face area - sq. ft. total		111.2	111.2	
	Tube diameter - in.		3/8	3/8	
	Number of rows		3	3	
	Fins per inch		20	20	
Condenser Fans	Motor horsepower		(6) 1	(6) 1	
	Motor rpm		1140	1140	
	Total Motor watts		5000	5000	
	Diameter - in.		(6) 24	(6) 24	
	No. of blades		4	4	
	Total Air volume - cfm		35,000	35,000	
Evaporator Coils	Net face area - sq. ft. total		37.4	37.4	
	Tube diameter - in.		3/8	3/8	
	No. of rows		4	4	
	Fins per inch		14	14	
	Drain connection - number and size		(1) 1 in. NPT coupling	(1) 1 in. NPT coupling	
	Expansion device type		Balanced Port Thermostatic Expansion Valve, removeable power head		
Indoor Blower and Drive Selection	Nominal motor output		5 to 30 hp available - See Blower Data Tables for selection		
	Motor - Drive kit		510 to 1340 rpm available - See Blower Drive Kit Tables for selection	510 to 1340 rpm available - See Blower Drive Kit Tables for selection	
	Blower wheel nominal dia. x width - in.		(2) 20 x 15	(2) 20 x 15	
Filters	Type of filter		Disposable, pleated MERV 4		
	No. and size - in.		(11) 25 x 16 x 2		
Electrical characteristics			208/230V, 460V or 575V - 60 hertz - 3 phase		

NOTE - Net capacity includes evaporator blower motor heat deduction. Gross capacity does not include evaporator blower motor heat deduction.

¹ Tested at conditions included in AHRI Standard 340/360; 95°F outdoor air temperature and 80°F db/67°F wb entering evaporator air; minimum external duct static pressure.

² Integrated Energy Efficiency Ratio tested according to AHRI Standard 340/360.

RATINGS

35 TON STANDARD EFFICIENCY LCH420S4V (1 COMPRESSOR - FULL LOAD) - VARIABLE AIR VOLUME

Entering Wet Bulb Temperature	Total Air Volume	Outdoor Air Temperature Entering Outdoor Coil																			
		65°F					75°F					85°F					95°F				
		Total Cool Cap.	Comp. Motor Input	Sensible To Total Ratio (S/T)			Total Cool Cap.	Comp. Motor Input	Sensible To Total Ratio (S/T)			Total Cool Cap.	Comp. Motor Input	Sensible To Total Ratio (S/T)			Total Cool Cap.	Comp. Motor Input	Sensible To Total Ratio (S/T)		
				Dry Bulb					Dry Bulb					Dry Bulb					Dry Bulb		
cfm	kBtuh	kW	75°F	80°F	85°F	kBtuh	kW	75°F	80°F	85°F	kBtuh	kW	75°F	80°F	85°F	kBtuh	kW	75°F	80°F	85°F	
63°F	2800	83.4	4.93	0.48	0.59	0.73	74.5	5.52	0.49	0.61	0.72	67.2	6.16	0.46	0.59	0.72	59.9	6.9	0.43	0.57	0.71
	3500	91.9	4.99	0.55	0.67	0.78	84.3	5.58	0.53	0.66	0.79	76.5	6.22	0.51	0.65	0.79	68.7	6.97	0.48	0.64	0.8
	4200	99.8	5.05	0.58	0.71	0.83	91.6	5.63	0.57	0.71	0.84	83.5	6.28	0.55	0.71	0.85	75.1	7	0.53	0.71	0.87
67°F	2800	87.5	4.96	0.45	0.54	0.59	81.6	5.55	0.42	0.47	0.58	74.3	6.2	0.39	0.45	0.56	66.7	6.94	0.36	0.42	0.54
	3500	99.5	5.04	0.42	0.53	0.63	91.7	5.63	0.4	0.51	0.62	83.8	6.27	0.37	0.49	0.62	75.8	7	0.34	0.47	0.61
	4200	107.7	5.11	0.44	0.56	0.67	99.3	5.68	0.42	0.54	0.67	91.1	6.34	0.4	0.53	0.67	82.3	7.04	0.37	0.52	0.67
71°F	2800	94.2	4.99	0.37	0.44	0.52	86.7	5.59	0.33	0.42	0.5	79.3	6.24	0.3	0.39	0.48	71.6	6.96	0.25	0.36	0.41
	3500	105.2	5.09	0.38	0.47	0.51	97.3	5.67	0.35	0.45	0.49	89.3	6.32	0.32	0.42	0.47	82.6	7.03	0.29	0.34	0.45
	4200	115.2	5.16	0.39	0.43	0.53	106.8	5.74	0.37	0.41	0.52	98.4	6.38	0.34	0.39	0.51	89.7	7.11	0.23	0.37	0.5

35 TON STANDARD EFFICIENCY LCH420S4V (2 COMPRESSORS - FULL LOAD) - VARIABLE AIR VOLUME

Entering Wet Bulb Temperature	Total Air Volume	Outdoor Air Temperature Entering Outdoor Coil																			
		65°F					75°F					85°F					95°F				
		Total Cool Cap.	Comp. Motor Input	Sensible To Total Ratio (S/T)			Total Cool Cap.	Comp. Motor Input	Sensible To Total Ratio (S/T)			Total Cool Cap.	Comp. Motor Input	Sensible To Total Ratio (S/T)			Total Cool Cap.	Comp. Motor Input	Sensible To Total Ratio (S/T)		
				Dry Bulb					Dry Bulb					Dry Bulb					Dry Bulb		
cfm	kBtuh	kW	75°F	80°F	85°F	kBtuh	kW	75°F	80°F	85°F	kBtuh	kW	75°F	80°F	85°F	kBtuh	kW	75°F	80°F	85°F	
63°F	5600	222.5	10.3	0.62	0.77	0.91	204.6	11.45	0.62	0.78	0.93	187.4	12.74	0.62	0.79	0.95	169.2	14.17	0.61	0.8	0.98
	7000	238.6	10.44	0.67	0.84	0.98	219.7	11.58	0.67	0.85	0.99	200.7	12.84	0.68	0.87	1	182.1	14.27	0.68	0.89	1
	8400	249.1	10.51	0.72	0.9	1	230.4	11.67	0.73	0.92	1	210.9	12.93	0.74	0.95	1	191.1	14.36	0.75	0.97	1
67°F	5600	238.7	10.42	0.47	0.6	0.73	220.8	11.57	0.46	0.6	0.74	202.8	12.85	0.44	0.6	0.75	184	14.27	0.42	0.59	0.76
	7000	255.2	10.57	0.5	0.65	0.81	235.7	11.7	0.49	0.65	0.82	216.6	12.97	0.48	0.66	0.83	196.9	14.4	0.47	0.66	0.85
	8400	266.4	10.66	0.53	0.7	0.87	246.6	11.8	0.53	0.71	0.88	226.5	13.06	0.52	0.72	0.91	206.2	14.48	0.52	0.73	0.94
71°F	5600	255.2	10.54	0.34	0.46	0.58	236.6	11.69	0.32	0.45	0.58	218.1	12.96	0.29	0.44	0.58	198.8	14.38	0.26	0.42	0.58
	7000	271.8	10.69	0.35	0.49	0.63	252.2	11.83	0.33	0.49	0.63	232.5	13.1	0.31	0.48	0.64	212.1	14.51	0.28	0.47	0.64
	8400	283.6	10.8	0.36	0.52	0.68	263.1	11.93	0.35	0.52	0.69	242.7	13.2	0.32	0.52	0.7	222.1	14.63	0.3	0.52	0.71

35 TON STANDARD EFFICIENCY LCH420S4V (3 COMPRESSORS - FULL LOAD) - VARIABLE AIR VOLUME

Entering Wet Bulb Temperature	Total Air Volume	Outdoor Air Temperature Entering Outdoor Coil																			
		85°F					95°F					105°F					115°F				
		Total Cool Cap.	Comp. Motor Input	Sensible To Total Ratio (S/T)			Total Cool Cap.	Comp. Motor Input	Sensible To Total Ratio (S/T)			Total Cool Cap.	Comp. Motor Input	Sensible To Total Ratio (S/T)			Total Cool Cap.	Comp. Motor Input	Sensible To Total Ratio (S/T)		
				Dry Bulb					Dry Bulb					Dry Bulb					Dry Bulb		
cfm	kBtuh	kW	75°F	80°F	85°F	kBtuh	kW	75°F	80°F	85°F	kBtuh	kW	75°F	80°F	85°F	kBtuh	kW	75°F	80°F	85°F	
63°F	8400	355.6	15.53	0.63	0.77	0.88	328.6	17.27	0.63	0.78	0.89	301	19.17	0.63	0.79	0.89	272.6	21.34	0.62	0.8	0.9
	10,500	377.2	15.72	0.68	0.83	0.92	349.1	17.44	0.68	0.85	0.93	321.8	19.35	0.69	0.86	0.94	294.4	21.5	0.69	0.86	0.95
	12,600	396.2	15.89	0.73	0.88	0.96	367.9	17.6	0.74	0.89	0.97	340.7	19.53	0.74	0.89	0.98	311.1	21.67	0.75	0.9	0.99
67°F	8400	380.6	15.74	0.5	0.61	0.74	352.3	17.46	0.48	0.62	0.74	324	19.36	0.47	0.61	0.75	294.9	21.51	0.46	0.61	0.76
	10,500	402	15.93	0.52	0.66	0.81	373.5	17.67	0.52	0.66	0.82	342.6	19.53	0.51	0.66	0.83	312	21.69	0.5	0.67	0.84
	12,600	418	16.08	0.55	0.7	0.86	387.3	17.79	0.55	0.71	0.86	355.9	19.66	0.54	0.72	0.87	324.2	21.8	0.54	0.73	0.88
71°F	8400	406.2	15.96	0.37	0.49	0.6	376.8	17.67	0.35	0.47	0.59	347.7	19.58	0.32	0.46	0.59	318.2	21.73	0.3	0.45	0.59
	10,500	427.8	16.16	0.37	0.51	0.64	397.4	17.87	0.35	0.51	0.64	367.4	19.77	0.34	0.49	0.64	335.3	21.89	0.32	0.49	0.65
	12,600	442.8	16.29	0.39	0.54	0.68	411.9	18	0.37	0.54	0.69	380.2	19.89	0.36	0.54	0.7	347.4	22.01	0.34	0.54	0.71

35 TON STANDARD EFFICIENCY LCH420S4V (4 COMPRESSORS - FULL LOAD) - VARIABLE AIR VOLUME

Entering Wet Bulb Temperature	Total Air Volume	Outdoor Air Temperature Entering Outdoor Coil																			
		85°F					95°F					105°F					115°F				
		Total Cool Cap.	Comp. Motor Input	Sensible To Total Ratio (S/T)			Total Cool Cap.	Comp. Motor Input	Sensible To Total Ratio (S/T)			Total Cool Cap.	Comp. Motor Input	Sensible To Total Ratio (S/T)			Total Cool Cap.	Comp. Motor Input	Sensible To Total Ratio (S/T)		
				Dry Bulb					Dry Bulb					Dry Bulb					Dry Bulb		
cfm	kBtuh	kW	75°F	80°F	85°F	kBtuh	kW	75°F	80°F	85°F	kBtuh	kW	75°F	80°F	85°F	kBtuh	kW	75°F	80°F	85°F	
63°F	11,200	427.1	25.75	0.65	0.8	0.92	390.1	28.6	0.64	0.81	0.94	350.9	31.9	0.64	0.82	0.96	311.1	35.65	0.64	0.84	0.99
	14,000	454.8	26.01	0.71	0.87	0.99	415.5	28.88	0.71	0.88	1	374.6	32.09	0.7	0.9	1	332.7	35.85	0.73	0.92	1
	16,800	474.6	26.18	0.76	0.92	1	433.7	29.03	0.78	0.94	1	392.2	32.26	0.79	0.97	1	349.2	35.97	0.8	0.99	1
67°F	11,200	453.9	25.97	0.48	0.62	0.77	414.3	28.83	0.46	0.62	0.78	372.7	32.08	0.46	0.62	0.79	329.4	35.82	0.43	0.63	0.8
	14,000	476.4	26.2	0.5	0.68	0.84	433.6	29.02	0.5	0.69	0.85	391.8	32.26	0.51	0.69	0.87	347.7	36.01	0.48	0.73	0.89
	16,800	491.3	26.33	0.55	0.74	0.9	449.9	29.19	0.55	0.76	0.91	406	32.41	0.57	0.77	0.94	362.9	36.17	0.57	0.78	0.97
71°F	11,200	486.5	26.29	0.34	0.47	0.6	443.5	29.12	0.33	0.48	0.6	402.4	32.39	0.3	0.46	0.61	357.3	36.09	0.26	0.43	0.62
	14,000	508.7	26.51	0.36	0.51	0.66	464.4	29.33	0.34	0.5	0.67	419.6	32.52	0.32	0.5	0.68	373.7	36.27	0.31	0.52	0.68
	16,800	523	26.64	0.38	0.55	0.72	478.7	29.48	0.36	0.55	0.73	433.3	32.7	0.35	0.55	0.76	386.2	36.4	0.33	0.55	0.77

RATINGS

35 TON STANDARD EFFICIENCY LCH420S4M (2 COMPRESSORS - FULL LOAD) - MSAV® (Multi-Stage Air Volume)

Entering Wet Bulb Temperature	Total Air Volume	Outdoor Air Temperature Entering Outdoor Coil																			
		65°F					75°F					85°F					95°F				
		Total Cool Cap.	Comp. Motor Input	Sensible To Total Ratio (S/T)			Total Cool Cap.	Comp. Motor Input	Sensible To Total Ratio (S/T)			Total Cool Cap.	Comp. Motor Input	Sensible To Total Ratio (S/T)			Total Cool Cap.	Comp. Motor Input	Sensible To Total Ratio (S/T)		
				Dry Bulb					Dry Bulb					Dry Bulb					Dry Bulb		
cfm	kBtuh	kW	75°F	80°F	85°F	kBtuh	kW	75°F	80°F	85°F	kBtuh	kW	75°F	80°F	85°F	kBtuh	kW	75°F	80°F	85°F	
63°F	5600	231.6	9.96	0.67	0.80	0.93	217.9	11.11	0.67	0.81	0.95	204.0	12.35	0.68	0.82	0.97	189.3	13.72	0.67	0.84	0.98
	7000	246.2	10.08	0.71	0.86	0.99	231.5	11.22	0.72	0.88	1.00	216.4	12.46	0.72	0.90	1.00	200.8	13.83	0.73	0.92	1.00
	8400	257.1	10.17	0.75	0.92	1.00	241.2	11.29	0.76	0.94	1.00	225.2	12.53	0.77	0.96	1.00	209.8	13.91	0.79	0.98	1.00
67°F	5600	245.3	10.06	0.53	0.65	0.77	231.3	11.21	0.52	0.65	0.78	216.8	12.45	0.52	0.66	0.79	201.9	13.84	0.51	0.66	0.81
	7000	261.1	10.20	0.55	0.69	0.83	245.4	11.33	0.55	0.70	0.85	230.2	12.57	0.55	0.71	0.86	214.4	13.95	0.55	0.71	0.88
	8400	272.1	10.28	0.58	0.74	0.89	256.3	11.42	0.58	0.74	0.91	239.7	12.65	0.56	0.75	0.93	223.3	14.04	0.57	0.77	0.96
71°F	5600	258.7	10.16	0.43	0.51	0.65	243.6	11.30	0.42	0.54	0.63	229.3	12.55	0.41	0.51	0.64	214.1	13.94	0.36	0.51	0.64
	7000	274.9	10.30	0.44	0.54	0.67	259.1	11.44	0.40	0.54	0.68	243.2	12.68	0.39	0.54	0.69	227.3	14.06	0.38	0.52	0.69
	8400	286.7	10.40	0.42	0.57	0.71	270.4	11.53	0.41	0.55	0.72	253.9	12.77	0.40	0.55	0.73	236.6	14.15	0.36	0.56	0.74

35 TON STANDARD EFFICIENCY LCH420S4M (4 COMPRESSORS - FULL LOAD) - MSAV® (Multi-Stage Air Volume)

Entering Wet Bulb Temperature	Total Air Volume	Outdoor Air Temperature Entering Outdoor Coil																			
		85°F					95°F					105°F					115°F				
		Total Cool Cap.	Comp. Motor Input	Sensible To Total Ratio (S/T)			Total Cool Cap.	Comp. Motor Input	Sensible To Total Ratio (S/T)			Total Cool Cap.	Comp. Motor Input	Sensible To Total Ratio (S/T)			Total Cool Cap.	Comp. Motor Input	Sensible To Total Ratio (S/T)		
				Dry Bulb					Dry Bulb					Dry Bulb					Dry Bulb		
cfm	kBtuh	kW	75°F	80°F	85°F	kBtuh	kW	75°F	80°F	85°F	kBtuh	kW	75°F	80°F	85°F	kBtuh	kW	75°F	80°F	85°F	
63°F	11,200	436.5	24.73	0.63	0.79	0.92	395.7	27.64	0.62	0.79	0.93	352.5	30.88	0.62	0.81	0.95	308.5	34.68	0.61	0.82	0.98
	14,000	468.3	24.80	0.69	0.86	0.99	424.1	27.66	0.69	0.87	1.00	378.8	30.92	0.71	0.89	1.00	332.7	34.70	0.71	0.91	1.00
	16,800	490.5	24.90	0.74	0.92	1.00	445.1	27.74	0.77	0.93	1.00	398.8	31.00	0.78	0.96	1.00	351.5	34.78	0.79	0.99	1.00
67°F	11,200	468.2	24.85	0.47	0.61	0.75	424.5	27.73	0.45	0.60	0.77	378.0	30.95	0.44	0.61	0.78	329.2	34.68	0.41	0.61	0.79
	14,000	493.4	24.87	0.50	0.67	0.83	445.1	27.71	0.51	0.69	0.84	397.9	30.97	0.49	0.68	0.85	350.1	34.75	0.49	0.68	0.88
	16,800	511.7	24.90	0.55	0.72	0.89	463.4	27.79	0.53	0.75	0.91	415.1	31.02	0.55	0.75	0.93	366.9	34.74	0.54	0.77	0.95
71°F	11,200	504.1	24.89	0.33	0.47	0.58	457.2	27.77	0.30	0.45	0.59	410.4	30.94	0.27	0.43	0.58	361.2	34.72	0.23	0.41	0.58
	14,000	529.7	24.98	0.35	0.50	0.66	481.6	27.80	0.31	0.49	0.67	430.7	31.06	0.30	0.50	0.66	380.6	34.79	0.27	0.46	0.67
	16,800	546.2	25.07	0.37	0.55	0.71	496.4	27.89	0.35	0.54	0.71	446.2	31.05	0.31	0.52	0.73	392.6	34.75	0.31	0.55	0.76

RATINGS

35 TON HIGH EFFICIENCY LCH420H4V (1 COMPRESSOR - FULL LOAD) - VARIABLE AIR VOLUME

Entering Wet Bulb Temperature	Total Air Volume	Outdoor Air Temperature Entering Outdoor Coil																			
		65°F					75°F					85°F					95°F				
		Total Cool Cap.	Comp. Motor Input	Sensible To Total Ratio (S/T)			Total Cool Cap.	Comp. Motor Input	Sensible To Total Ratio (S/T)			Total Cool Cap.	Comp. Motor Input	Sensible To Total Ratio (S/T)			Total Cool Cap.	Comp. Motor Input	Sensible To Total Ratio (S/T)		
				Dry Bulb					Dry Bulb					Dry Bulb					Dry Bulb		
cfm	kBtuh	kW	75°F	80°F	85°F	kBtuh	kW	75°F	80°F	85°F	kBtuh	kW	75°F	80°F	85°F	kBtuh	kW	75°F	80°F	85°F	
63°F	2800	83	4.87	0.47	0.57	0.72	73.2	5.47	0.47	0.59	0.71	65.1	6.1	0.43	0.57	0.7	57	6.85	0.39	0.54	0.69
	3500	92.2	4.88	0.54	0.66	0.78	83.7	5.46	0.52	0.65	0.78	75.1	6.12	0.49	0.63	0.78	66.4	6.89	0.46	0.62	0.78
	4200	101.1	4.89	0.57	0.7	0.83	92.1	5.48	0.55	0.7	0.83	82.8	6.16	0.53	0.69	0.84	73.5	6.88	0.51	0.69	0.86
67°F	2800	89.1	4.88	0.44	0.49	0.58	81	5.47	0.41	0.46	0.56	72.8	6.11	0.37	0.42	0.54	64.4	6.86	0.32	0.38	0.51
	3500	100.7	4.9	0.41	0.52	0.62	92	5.49	0.39	0.5	0.61	83.2	6.14	0.35	0.47	0.6	74.2	6.87	0.31	0.44	0.59
	4200	109.8	4.91	0.43	0.55	0.66	100.6	5.5	0.41	0.53	0.66	91.4	6.16	0.38	0.52	0.66	81.7	6.88	0.34	0.5	0.65
71°F	2800	94.9	4.88	0.35	0.43	0.51	86.6	5.47	0.32	0.4	0.49	78.2	6.13	0.27	0.37	0.46	69.8	6.85	0.22	0.33	0.38
	3500	107	4.9	0.37	0.46	0.5	100.1	5.5	0.34	0.38	0.48	91.1	6.15	0.3	0.35	0.46	82	6.86	0.26	0.31	0.43
	4200	118.4	4.93	0.38	0.42	0.53	108.9	5.52	0.29	0.4	0.51	99.5	6.15	0.32	0.38	0.5	89.8	6.89	0.21	0.35	0.48

35 TON HIGH EFFICIENCY LCH420H4V (2 COMPRESSORS - FULL LOAD) - VARIABLE AIR VOLUME

Entering Wet Bulb Temperature	Total Air Volume	Outdoor Air Temperature Entering Outdoor Coil																			
		65°F					75°F					85°F					95°F				
		Total Cool Cap.	Comp. Motor Input	Sensible To Total Ratio (S/T)			Total Cool Cap.	Comp. Motor Input	Sensible To Total Ratio (S/T)			Total Cool Cap.	Comp. Motor Input	Sensible To Total Ratio (S/T)			Total Cool Cap.	Comp. Motor Input	Sensible To Total Ratio (S/T)		
				Dry Bulb					Dry Bulb					Dry Bulb					Dry Bulb		
cfm	kBtuh	kW	75°F	80°F	85°F	kBtuh	kW	75°F	80°F	85°F	kBtuh	kW	75°F	80°F	85°F	kBtuh	kW	75°F	80°F	85°F	
63°F	5600	228.1	9.82	0.61	0.76	0.91	208.1	11.01	0.61	0.77	0.92	188.2	12.29	0.6	0.78	0.95	167.8	13.77	0.59	0.79	0.97
	7000	245.3	9.86	0.66	0.83	0.98	224.6	11.06	0.66	0.85	0.99	203.4	12.36	0.67	0.86	1	182.7	13.79	0.67	0.88	1
	8400	258.5	9.93	0.71	0.89	1	236.8	11.09	0.72	0.91	1	214.8	12.38	0.73	0.93	1	193.4	13.79	0.73	0.96	1
67°F	5600	246.6	9.89	0.46	0.59	0.72	226.4	11.03	0.45	0.59	0.73	205.7	12.35	0.43	0.58	0.74	185.1	13.79	0.4	0.58	0.75
	7000	264.9	9.94	0.49	0.64	0.79	243.1	11.11	0.48	0.64	0.81	221.4	12.39	0.47	0.64	0.82	199.3	13.83	0.45	0.65	0.84
	8400	277.9	9.98	0.52	0.69	0.86	255.5	11.14	0.51	0.7	0.87	232.6	12.42	0.51	0.7	0.89	210.9	13.85	0.5	0.71	0.92
71°F	5600	264.6	9.93	0.33	0.46	0.57	243.6	11.09	0.31	0.44	0.57	222.9	12.35	0.28	0.42	0.56	201.7	13.8	0.24	0.4	0.56
	7000	283.2	9.97	0.35	0.49	0.62	261.3	11.14	0.33	0.48	0.62	239.7	12.41	0.3	0.46	0.62	216.8	13.86	0.27	0.45	0.63
	8400	297.1	10.04	0.36	0.52	0.67	274.7	11.18	0.34	0.51	0.67	251.1	12.47	0.32	0.5	0.68	228	13.88	0.29	0.5	0.69

35 TON HIGH EFFICIENCY LCH420H4V (3 COMPRESSORS - FULL LOAD) - VARIABLE AIR VOLUME

Entering Wet Bulb Temperature	Total Air Volume	Outdoor Air Temperature Entering Outdoor Coil																			
		85°F					95°F					105°F					115°F				
		Total Cool Cap.	Comp. Motor Input	Sensible To Total Ratio (S/T)			Total Cool Cap.	Comp. Motor Input	Sensible To Total Ratio (S/T)			Total Cool Cap.	Comp. Motor Input	Sensible To Total Ratio (S/T)			Total Cool Cap.	Comp. Motor Input	Sensible To Total Ratio (S/T)		
				Dry Bulb					Dry Bulb					Dry Bulb					Dry Bulb		
cfm	kBtuh	kW	75°F	80°F	85°F	kBtuh	kW	75°F	80°F	85°F	kBtuh	kW	75°F	80°F	85°F	kBtuh	kW	75°F	80°F	85°F	
63°F	8400	367.7	14.8	0.63	0.77	0.88	337.1	16.57	0.62	0.77	0.88	305.9	18.52	0.62	0.78	0.89	274.6	20.66	0.62	0.8	0.9
	10,500	391.2	14.85	0.67	0.83	0.92	359.9	16.63	0.67	0.84	0.93	328.9	18.57	0.68	0.85	0.93	297.8	20.72	0.68	0.85	0.94
	12,600	412.6	14.94	0.72	0.87	0.95	380.6	16.69	0.73	0.88	0.96	350	18.63	0.73	0.89	0.97	316.5	20.76	0.75	0.89	0.99
67°F	8400	395.7	14.88	0.49	0.61	0.73	363.8	16.64	0.47	0.61	0.73	331.8	18.58	0.46	0.6	0.74	300.4	20.75	0.44	0.59	0.75
	10,500	419.5	14.96	0.51	0.65	0.8	386.4	16.72	0.51	0.65	0.8	353.2	18.62	0.5	0.65	0.82	319.5	20.77	0.48	0.65	0.83
	12,600	437.7	15.02	0.54	0.7	0.85	403.4	16.75	0.54	0.71	0.86	368	18.67	0.53	0.71	0.87	333.5	20.82	0.52	0.71	0.87
71°F	8400	424.1	14.95	0.37	0.48	0.59	391.8	16.7	0.35	0.47	0.59	358.5	18.64	0.32	0.45	0.58	325.5	20.78	0.28	0.44	0.58
	10,500	449	15.08	0.37	0.5	0.63	414.8	16.79	0.35	0.5	0.63	380.2	18.69	0.33	0.49	0.63	344.9	20.81	0.3	0.48	0.63
	12,600	466.5	15.14	0.38	0.53	0.67	431.3	16.85	0.36	0.53	0.68	395.9	18.77	0.35	0.53	0.69	359.1	20.83	0.33	0.52	0.7

35 TON HIGH EFFICIENCY LCH420H4V (4 COMPRESSORS - FULL LOAD) - VARIABLE AIR VOLUME

Entering Wet Bulb Temperature	Total Air Volume	Outdoor Air Temperature Entering Outdoor Coil																			
		85°F					95°F					105°F					115°F				
		Total Cool Cap.	Comp. Motor Input	Sensible To Total Ratio (S/T)			Total Cool Cap.	Comp. Motor Input	Sensible To Total Ratio (S/T)			Total Cool Cap.	Comp. Motor Input	Sensible To Total Ratio (S/T)			Total Cool Cap.	Comp. Motor Input	Sensible To Total Ratio (S/T)		
				Dry Bulb					Dry Bulb					Dry Bulb					Dry Bulb		
cfm	kBtuh	kW	75°F	80°F	85°F	kBtuh	kW	75°F	80°F	85°F	kBtuh	kW	75°F	80°F	85°F	kBtuh	kW	75°F	80°F	85°F	
63°F	11,200	436.5	24.73	0.63	0.79	0.92	395.7	27.64	0.62	0.79	0.93	352.5	30.88	0.62	0.81	0.95	308.5	34.68	0.61	0.82	0.98
	14,000	468.3	24.8	0.69	0.86	0.99	424.1	27.66	0.69	0.87	1	378.8	30.92	0.71	0.89	1	332.7	34.7	0.71	0.91	1
	16,800	490.5	24.9	0.74	0.92	1	445.1	27.74	0.77	0.93	1	398.8	31	0.78	0.96	1	351.5	34.78	0.79	0.99	1
67°F	11,200	468.2	24.85	0.47	0.61	0.75	424.5	27.73	0.45	0.6	0.77	378	30.95	0.44	0.61	0.78	329.2	34.68	0.41	0.61	0.79
	14,000	493.4	24.87	0.5	0.67	0.83	445.1	27.71	0.51	0.69	0.84	397.9	30.97	0.49	0.68	0.85	350.1	34.75	0.49	0.68	0.88
	16,800	511.7	24.9	0.55	0.72	0.89	463.4	27.79	0.53	0.75	0.91	415.1	31.02	0.55	0.75	0.93	366.9	34.74	0.54	0.77	0.95
71°F	11,200	504.1	24.89	0.33	0.47	0.58	457.2	27.77	0.3	0.45	0.59	410.4	30.94	0.27	0.43	0.58	361.2	34.72	0.23	0.41	0.58
	14,000	529.7	24.98	0.35	0.5	0.66	481.6	27.8	0.31	0.49	0.67	430.7	31.06	0.3	0.5	0.66	380.6	34.79	0.27	0.46	0.67
	16,800	546.2	25.07	0.37	0.55	0.71	496.4	27.89	0.35	0.54	0.71	446.2	31.05	0.31	0.52	0.73	392.6	34.75	0.31	0.55	0.76

RATINGS

35 TON HIGH EFFICIENCY LCH420H4M (2 COMPRESSORS - FULL LOAD) - MSAV® (Multi-Stage Air Volume)

Entering Wet Bulb Temperature	Total Air Volume	Outdoor Air Temperature Entering Outdoor Coil																			
		65°F					75°F					85°F					95°F				
		Total Cool Cap.	Comp. Motor Input	Sensible To Total Ratio (S/T)			Total Cool Cap.	Comp. Motor Input	Sensible To Total Ratio (S/T)			Total Cool Cap.	Comp. Motor Input	Sensible To Total Ratio (S/T)			Total Cool Cap.	Comp. Motor Input	Sensible To Total Ratio (S/T)		
				Dry Bulb					Dry Bulb					Dry Bulb					Dry Bulb		
cfm	kBtuh	kW	75°F	80°F	85°F	kBtuh	kW	75°F	80°F	85°F	kBtuh	kW	75°F	80°F	85°F	kBtuh	kW	75°F	80°F	85°F	
63°F	5600	231.6	9.96	0.67	0.80	0.93	217.9	11.11	0.67	0.81	0.95	204.0	12.35	0.68	0.82	0.97	189.3	13.72	0.67	0.84	0.98
	7000	246.2	10.08	0.71	0.86	0.99	231.5	11.22	0.72	0.88	1.00	216.4	12.46	0.72	0.90	1.00	200.8	13.83	0.73	0.92	1.00
	8400	257.1	10.17	0.75	0.92	1.00	241.2	11.29	0.76	0.94	1.00	225.2	12.53	0.77	0.96	1.00	209.8	13.91	0.79	0.98	1.00
67°F	5600	245.3	10.06	0.53	0.65	0.77	231.3	11.21	0.52	0.65	0.78	216.8	12.45	0.52	0.66	0.79	201.9	13.84	0.51	0.66	0.81
	7000	261.1	10.20	0.55	0.69	0.83	245.4	11.33	0.55	0.70	0.85	230.2	12.57	0.55	0.71	0.86	214.4	13.95	0.55	0.71	0.88
	8400	272.1	10.28	0.58	0.74	0.89	256.3	11.42	0.58	0.74	0.91	239.7	12.65	0.56	0.75	0.93	223.3	14.04	0.57	0.77	0.96
71°F	5600	258.7	10.16	0.43	0.51	0.65	243.6	11.30	0.42	0.54	0.63	229.3	12.55	0.41	0.51	0.64	214.1	13.94	0.36	0.51	0.64
	7000	274.9	10.30	0.44	0.54	0.67	259.1	11.44	0.40	0.54	0.68	243.2	12.68	0.39	0.54	0.69	227.3	14.06	0.38	0.52	0.69
	8400	286.7	10.40	0.42	0.57	0.71	270.4	11.53	0.41	0.55	0.72	253.9	12.77	0.40	0.55	0.73	236.6	14.15	0.36	0.56	0.74

35 TON HIGH EFFICIENCY LCH420H4M (4 COMPRESSORS - FULL LOAD) - MSAV® (Multi-Stage Air Volume)

Entering Wet Bulb Temperature	Total Air Volume	Outdoor Air Temperature Entering Outdoor Coil																			
		85°F					95°F					105°F					115°F				
		Total Cool Cap.	Comp. Motor Input	Sensible To Total Ratio (S/T)			Total Cool Cap.	Comp. Motor Input	Sensible To Total Ratio (S/T)			Total Cool Cap.	Comp. Motor Input	Sensible To Total Ratio (S/T)			Total Cool Cap.	Comp. Motor Input	Sensible To Total Ratio (S/T)		
				Dry Bulb					Dry Bulb					Dry Bulb					Dry Bulb		
cfm	kBtuh	kW	75°F	80°F	85°F	kBtuh	kW	75°F	80°F	85°F	kBtuh	kW	75°F	80°F	85°F	kBtuh	kW	75°F	80°F	85°F	
63°F	11,200	436.5	24.73	0.63	0.79	0.92	395.7	27.64	0.62	0.79	0.93	352.5	30.88	0.62	0.81	0.95	308.5	34.68	0.61	0.82	0.98
	14,000	468.3	24.80	0.69	0.86	0.99	424.1	27.66	0.69	0.87	1.00	378.8	30.92	0.71	0.89	1.00	332.7	34.70	0.71	0.91	1.00
	16,800	490.5	24.90	0.74	0.92	1.00	445.1	27.74	0.77	0.93	1.00	398.8	31.00	0.78	0.96	1.00	351.5	34.78	0.79	0.99	1.00
67°F	11,200	468.2	24.85	0.47	0.61	0.75	424.5	27.73	0.45	0.60	0.77	378.0	30.95	0.44	0.61	0.78	329.2	34.68	0.41	0.61	0.79
	14,000	493.4	24.87	0.50	0.67	0.83	445.1	27.71	0.51	0.69	0.84	397.9	30.97	0.49	0.68	0.85	350.1	34.75	0.49	0.68	0.88
	16,800	511.7	24.90	0.55	0.72	0.89	463.4	27.79	0.53	0.75	0.91	415.1	31.02	0.55	0.75	0.93	366.9	34.74	0.54	0.77	0.95
71°F	11,200	504.1	24.89	0.33	0.47	0.58	457.2	27.77	0.30	0.45	0.59	410.4	30.94	0.27	0.43	0.58	361.2	34.72	0.23	0.41	0.58
	14,000	529.7	24.98	0.35	0.50	0.66	481.6	27.80	0.31	0.49	0.67	430.7	31.06	0.30	0.50	0.66	380.6	34.79	0.27	0.46	0.67
	16,800	546.2	25.07	0.37	0.55	0.71	496.4	27.89	0.35	0.54	0.71	446.2	31.05	0.31	0.52	0.73	392.6	34.75	0.31	0.55	0.76

RATINGS

40 TON STANDARD EFFICIENCY LCH480S4V (1 COMPRESSOR - FULL LOAD) - VARIABLE AIR VOLUME

Entering Wet Bulb Temperature	Total Air Volume	Outdoor Air Temperature Entering Outdoor Coil																			
		65°F					75°F					85°F					95°F				
		Total Cool Cap.	Comp. Motor Input	Sensible To Total Ratio (S/T)			Total Cool Cap.	Comp. Motor Input	Sensible To Total Ratio (S/T)			Total Cool Cap.	Comp. Motor Input	Sensible To Total Ratio (S/T)			Total Cool Cap.	Comp. Motor Input	Sensible To Total Ratio (S/T)		
				Dry Bulb					Dry Bulb					Dry Bulb					Dry Bulb		
cfm	kBtuh	kW	75°F	80°F	85°F	kBtuh	kW	75°F	80°F	85°F	kBtuh	kW	75°F	80°F	85°F	kBtuh	kW	75°F	80°F	85°F	
63°F	3200	93.7	5.51	0.52	0.59	0.73	84.3	6.21	0.46	0.61	0.73	76.4	7	0.47	0.6	0.72	68.2	7.91	0.44	0.58	0.72
	4000	103.1	5.61	0.56	0.67	0.79	94.8	6.31	0.54	0.66	0.79	86.3	7.09	0.52	0.66	0.79	77.7	8	0.49	0.65	0.8
	4800	111.6	5.7	0.58	0.71	0.84	103.1	6.4	0.57	0.71	0.84	94.1	7.18	0.56	0.71	0.85	84.7	8.06	0.54	0.71	0.87
67°F	3200	98.3	5.56	0.46	0.55	0.6	90.5	6.26	0.43	0.53	0.58	82.5	7.06	0.4	0.5	0.57	75.5	7.94	0.36	0.43	0.55
	4000	111.3	5.68	0.48	0.53	0.64	102.9	6.38	0.41	0.52	0.63	94.2	7.16	0.38	0.5	0.62	85.4	8.05	0.34	0.48	0.61
	4800	120.1	5.78	0.45	0.56	0.68	111.3	6.47	0.43	0.55	0.68	102.3	7.26	0.4	0.54	0.68	92.8	8.14	0.38	0.52	0.68
71°F	3200	105.6	5.62	0.37	0.45	0.53	97.6	6.32	0.34	0.43	0.51	89.5	7.11	0.31	0.4	0.49	81	8.01	0.26	0.37	0.47
	4000	117.5	5.75	0.39	0.47	0.56	109.1	6.45	0.36	0.45	0.5	100.2	7.22	0.33	0.43	0.48	92.9	8.11	0.29	0.34	0.46
	4800	126.7	5.85	0.4	0.49	0.54	119.3	6.55	0.37	0.42	0.53	110	7.32	0.35	0.4	0.52	100.6	8.21	0.31	0.37	0.51

40 TON STANDARD EFFICIENCY LCH480S4V (2 COMPRESSORS - FULL LOAD) - VARIABLE AIR VOLUME

Entering Wet Bulb Temperature	Total Air Volume	Outdoor Air Temperature Entering Outdoor Coil																			
		65°F					75°F					85°F					95°F				
		Total Cool Cap.	Comp. Motor Input	Sensible To Total Ratio (S/T)			Total Cool Cap.	Comp. Motor Input	Sensible To Total Ratio (S/T)			Total Cool Cap.	Comp. Motor Input	Sensible To Total Ratio (S/T)			Total Cool Cap.	Comp. Motor Input	Sensible To Total Ratio (S/T)		
				Dry Bulb					Dry Bulb					Dry Bulb					Dry Bulb		
cfm	kBtuh	kW	75°F	80°F	85°F	kBtuh	kW	75°F	80°F	85°F	kBtuh	kW	75°F	80°F	85°F	kBtuh	kW	75°F	80°F	85°F	
63°F	6400	247.6	11.67	0.63	0.78	0.92	229.5	13.07	0.62	0.78	0.94	210.3	14.61	0.62	0.79	0.96	190.2	16.36	0.62	0.8	0.97
	8000	264.6	11.88	0.68	0.85	0.99	245.3	13.26	0.68	0.86	0.99	224.7	14.78	0.68	0.87	1	203.8	16.52	0.69	0.89	1
	9600	276.6	12.02	0.73	0.91	1	256.6	13.39	0.73	0.93	1	235.4	14.91	0.74	0.95	1	214	16.64	0.75	0.96	1
67°F	6400	265.4	11.87	0.48	0.61	0.74	246.5	13.25	0.46	0.6	0.75	226.6	14.78	0.45	0.6	0.76	206.6	16.54	0.43	0.6	0.77
	8000	282.7	12.09	0.51	0.66	0.81	262.4	13.45	0.5	0.66	0.82	242	14.99	0.49	0.66	0.84	220.2	16.71	0.48	0.67	0.86
	9600	294.9	12.25	0.54	0.71	0.88	274.5	13.62	0.53	0.71	0.89	252.5	15.12	0.52	0.72	0.91	230.4	16.85	0.52	0.73	0.94
71°F	6400	282.6	12.05	0.34	0.47	0.59	263	13.41	0.32	0.46	0.58	243	14.95	0.29	0.44	0.58	222.2	16.69	0.26	0.43	0.58
	8000	300	12.29	0.36	0.5	0.64	279.4	13.64	0.34	0.49	0.64	258.8	15.18	0.31	0.48	0.64	236.7	16.9	0.29	0.47	0.65
	9600	312.9	12.48	0.37	0.53	0.69	291.8	13.83	0.35	0.53	0.69	269.8	15.34	0.33	0.52	0.7	246.8	17.05	0.3	0.52	0.71

40 TON STANDARD EFFICIENCY LCH480S4V (3 COMPRESSORS - FULL LOAD) - VARIABLE AIR VOLUME

Entering Wet Bulb Temperature	Total Air Volume	Outdoor Air Temperature Entering Outdoor Coil																			
		85°F					95°F					105°F					115°F				
		Total Cool Cap.	Comp. Motor Input	Sensible To Total Ratio (S/T)			Total Cool Cap.	Comp. Motor Input	Sensible To Total Ratio (S/T)			Total Cool Cap.	Comp. Motor Input	Sensible To Total Ratio (S/T)			Total Cool Cap.	Comp. Motor Input	Sensible To Total Ratio (S/T)		
				Dry Bulb					Dry Bulb					Dry Bulb					Dry Bulb		
cfm	kBtuh	kW	75°F	80°F	85°F	kBtuh	kW	75°F	80°F	85°F	kBtuh	kW	75°F	80°F	85°F	kBtuh	kW	75°F	80°F	85°F	
63°F	9600	395.4	17.66	0.64	0.78	0.89	366.8	19.72	0.64	0.79	0.89	336.8	22.02	0.64	0.79	0.9	305.8	24.65	0.63	0.81	0.9
	12,000	417.9	17.94	0.69	0.84	0.93	388.2	19.98	0.69	0.85	0.93	358.8	22.3	0.69	0.86	0.94	328.5	24.94	0.7	0.86	0.95
	14,400	438.3	18.21	0.74	0.88	0.96	408.4	20.26	0.74	0.89	0.97	378.3	22.57	0.75	0.9	0.98	346.4	25.17	0.75	0.9	0.99
67°F	9600	421.9	17.99	0.5	0.62	0.75	392.7	20.05	0.49	0.62	0.75	361.7	22.33	0.47	0.62	0.76	330	24.95	0.46	0.62	0.77
	12,000	445.2	18.31	0.53	0.66	0.82	413.7	20.33	0.52	0.67	0.82	382.2	22.63	0.51	0.67	0.83	348.8	25.21	0.5	0.67	0.84
	14,400	460.7	18.52	0.56	0.72	0.86	429.5	20.56	0.55	0.72	0.87	396	22.82	0.54	0.73	0.88	361	25.38	0.54	0.75	0.88
71°F	9600	448.8	18.34	0.37	0.49	0.61	418.8	20.39	0.35	0.48	0.6	387.3	22.67	0.33	0.47	0.6	354.2	25.26	0.3	0.46	0.6
	12,000	471.7	18.66	0.38	0.52	0.65	440.3	20.7	0.36	0.51	0.65	407.7	22.98	0.34	0.5	0.66	373.7	25.56	0.32	0.5	0.65
	14,400	489.1	18.93	0.39	0.54	0.69	455.5	20.92	0.37	0.55	0.7	421.7	23.18	0.36	0.54	0.71	386.2	25.74	0.33	0.54	0.72

40 TON STANDARD EFFICIENCY LCH480S4V (4 COMPRESSORS - FULL LOAD) - VARIABLE AIR VOLUME

Entering Wet Bulb Temperature	Total Air Volume	Outdoor Air Temperature Entering Outdoor Coil																			
		85°F					95°F					105°F					115°F				
		Total Cool Cap.	Comp. Motor Input	Sensible To Total Ratio (S/T)			Total Cool Cap.	Comp. Motor Input	Sensible To Total Ratio (S/T)			Total Cool Cap.	Comp. Motor Input	Sensible To Total Ratio (S/T)			Total Cool Cap.	Comp. Motor Input	Sensible To Total Ratio (S/T)		
				Dry Bulb					Dry Bulb					Dry Bulb					Dry Bulb		
cfm	kBtuh	kW	75°F	80°F	85°F	kBtuh	kW	75°F	80°F	85°F	kBtuh	kW	75°F	80°F	85°F	kBtuh	kW	75°F	80°F	85°F	
63°F	12,800	476.8	29.64	0.65	0.8	0.93	435.6	33.14	0.65	0.81	0.95	393.8	37.19	0.65	0.82	0.97	348.2	41.78	0.65	0.84	0.99
	16,000	506.2	30.07	0.71	0.87	0.99	463.4	33.55	0.72	0.89	1	418.1	37.49	0.72	0.91	1	370.7	42.03	0.74	0.93	1
	19,200	527.7	30.38	0.77	0.93	1	483.2	33.83	0.78	0.95	1	437.3	37.77	0.8	0.97	1	389.6	42.31	0.81	0.99	1
67°F	12,800	506.1	30.03	0.48	0.63	0.77	462.1	33.5	0.47	0.63	0.78	416.9	37.44	0.46	0.62	0.8	367.3	41.98	0.43	0.63	0.81
	16,000	528.2	30.35	0.51	0.7	0.85	484	33.81	0.52	0.69	0.86	436.2	37.73	0.51	0.71	0.87	387.2	42.26	0.48	0.73	0.9
	19,200	545.3	30.61	0.57	0.76	0.91	499.3	34.03	0.57	0.77	0.93	453.3	38	0.55	0.76	0.95	403.2	42.5	0.58	0.78	0.97
71°F	12,800	540.3	30.51	0.34	0.47	0.6	495.2	33.97	0.31	0.46	0.61	448.3	37.89	0.3	0.45	0.62	397.8	42.38	0.25	0.45	0.61
	16,000	563.9	30.88	0.35	0.51	0.67	517.2	34.31	0.33	0.51	0.68	466.9	38.17	0.31	0.52	0.69	415.3	42.65	0.28	0.51	0.7
	19,200	581.4	31.19	0.37	0.55	0.73	531.4	34.54	0.36	0.56	0.75	481	38.39	0.34	0.55	0.76	428.7	42.86	0.34	0.54	0.77

RATINGS

40 TON STANDARD EFFICIENCY LCH480S4M (2 COMPRESSORS - FULL LOAD) - MSAV® (MULTI-STAGE AIR VOLUME)

Entering Wet Bulb Temperature	Total Air Volume	Outdoor Air Temperature Entering Outdoor Coil																			
		65°F					75°F					85°F					95°F				
		Total Cool Cap.	Comp. Motor Input	Sensible To Total Ratio (S/T)			Total Cool Cap.	Comp. Motor Input	Sensible To Total Ratio (S/T)			Total Cool Cap.	Comp. Motor Input	Sensible To Total Ratio (S/T)			Total Cool Cap.	Comp. Motor Input	Sensible To Total Ratio (S/T)		
				Dry Bulb					Dry Bulb					Dry Bulb					Dry Bulb		
cfm	kBtuh	kW	75°F	80°F	85°F	kBtuh	kW	75°F	80°F	85°F	kBtuh	kW	75°F	80°F	85°F	kBtuh	kW	75°F	80°F	85°F	
63°F	6400	247.8	11.81	0.68	0.81	0.94	229.4	13.17	0.68	0.82	0.95	209.9	14.69	0.68	0.83	0.97	190.3	16.40	0.66	0.83	0.98
	8000	265.0	12.05	0.73	0.87	0.99	245.6	13.40	0.73	0.88	1.00	224.6	14.88	0.73	0.89	1.00	203.7	16.59	0.71	0.90	1.00
	9600	277.5	12.21	0.77	0.92	1.00	257.4	13.56	0.75	0.94	1.00	236.2	15.05	0.76	0.95	1.00	214.7	16.76	0.77	0.97	1.00
67°F	6400	266.1	12.05	0.52	0.66	0.78	247.1	13.41	0.51	0.66	0.79	227.2	14.93	0.50	0.66	0.80	205.1	16.61	0.49	0.66	0.79
	8000	282.9	12.29	0.56	0.71	0.84	261.6	13.61	0.55	0.71	0.85	240.7	15.12	0.55	0.71	0.86	219.6	16.84	0.55	0.72	0.87
	9600	294.6	12.45	0.59	0.75	0.89	272.8	13.77	0.59	0.75	0.90	251.9	15.28	0.56	0.74	0.92	228.9	16.97	0.55	0.75	0.94
71°F	6400	284.5	12.28	0.36	0.51	0.64	264.8	13.63	0.35	0.50	0.64	244.1	15.15	0.33	0.49	0.64	222.8	16.87	0.31	0.49	0.65
	8000	300.7	12.52	0.38	0.55	0.69	279.9	13.87	0.37	0.55	0.69	258.5	15.38	0.37	0.54	0.69	236.9	17.11	0.35	0.54	0.70
	9600	312.7	12.70	0.39	0.58	0.73	291.6	14.06	0.40	0.58	0.74	269.0	15.55	0.39	0.58	0.74	245.9	17.23	0.38	0.55	0.75

40 TON STANDARD EFFICIENCY LCH480S4M (4 COMPRESSORS - FULL LOAD) - MSAV® (MULTI-STAGE AIR VOLUME)

Entering Wet Bulb Temperature	Total Air Volume	Outdoor Air Temperature Entering Outdoor Coil																			
		85°F					95°F					105°F					115°F				
		Total Cool Cap.	Comp. Motor Input	Sensible To Total Ratio (S/T)			Total Cool Cap.	Comp. Motor Input	Sensible To Total Ratio (S/T)			Total Cool Cap.	Comp. Motor Input	Sensible To Total Ratio (S/T)			Total Cool Cap.	Comp. Motor Input	Sensible To Total Ratio (S/T)		
				Dry Bulb					Dry Bulb					Dry Bulb					Dry Bulb		
cfm	kBtuh	kW	75°F	80°F	85°F	kBtuh	kW	75°F	80°F	85°F	kBtuh	kW	75°F	80°F	85°F	kBtuh	kW	75°F	80°F	85°F	
63°F	12,800	476.8	29.64	0.65	0.80	0.93	435.6	33.14	0.65	0.81	0.95	393.8	37.19	0.65	0.82	0.97	348.2	41.78	0.65	0.84	0.99
	16,000	506.2	30.07	0.71	0.87	0.99	463.4	33.55	0.72	0.89	1.00	418.1	37.49	0.72	0.91	1.00	370.7	42.03	0.74	0.93	1.00
	19,200	527.7	30.38	0.77	0.93	1.00	483.2	33.83	0.78	0.95	1.00	437.3	37.77	0.80	0.97	1.00	389.6	42.31	0.81	0.99	1.00
67°F	12,800	506.1	30.03	0.48	0.63	0.77	462.1	33.50	0.47	0.63	0.78	416.9	37.44	0.46	0.62	0.80	367.3	41.98	0.43	0.63	0.81
	16,000	528.2	30.35	0.51	0.70	0.85	484.0	33.81	0.52	0.69	0.86	436.2	37.73	0.51	0.71	0.87	387.2	42.26	0.48	0.73	0.90
	19,200	545.3	30.61	0.57	0.76	0.91	499.3	34.03	0.57	0.77	0.93	453.3	38.00	0.55	0.76	0.95	403.2	42.50	0.58	0.78	0.97
71°F	12,800	540.3	30.51	0.34	0.47	0.60	495.2	33.97	0.31	0.46	0.61	448.3	37.89	0.30	0.45	0.62	397.8	42.38	0.25	0.45	0.61
	16,000	563.9	30.88	0.35	0.51	0.67	517.2	34.31	0.33	0.51	0.68	466.9	38.17	0.31	0.52	0.69	415.3	42.65	0.28	0.51	0.70
	19,200	581.4	31.19	0.37	0.55	0.73	531.4	34.54	0.36	0.56	0.75	481.0	38.39	0.34	0.55	0.76	428.7	42.86	0.34	0.54	0.77

RATINGS

40 TON HIGH EFFICIENCY LCH480H4V (1 COMPRESSOR - FULL LOAD) - VARIABLE AIR VOLUME

Entering Wet Bulb Temperature	Total Air Volume	Outdoor Air Temperature Entering Outdoor Coil																			
		65°F					75°F					85°F					95°F				
		Total Cool Cap.	Comp. Motor Input	Sensible To Total Ratio (S/T)			Total Cool Cap.	Comp. Motor Input	Sensible To Total Ratio (S/T)			Total Cool Cap.	Comp. Motor Input	Sensible To Total Ratio (S/T)			Total Cool Cap.	Comp. Motor Input	Sensible To Total Ratio (S/T)		
				Dry Bulb					Dry Bulb					Dry Bulb					Dry Bulb		
cfm	kBtuh	kW	75°F	80°F	85°F	kBtuh	kW	75°F	80°F	85°F	kBtuh	kW	75°F	80°F	85°F	kBtuh	kW	75°F	80°F	85°F	
63°F	3200	96.6	5.17	0.49	0.61	0.74	88.2	5.87	0.47	0.64	0.75	80.4	6.63	0.5	0.62	0.74	72.5	7.51	0.47	0.61	0.74
	4000	106	5.21	0.56	0.68	0.79	98.3	5.9	0.55	0.68	0.8	90.5	6.66	0.54	0.67	0.8	81.6	7.5	0.52	0.68	0.81
	4800	114.8	5.25	0.59	0.72	0.84	105.6	5.91	0.58	0.73	0.84	97.5	6.68	0.57	0.73	0.85	89.3	7.53	0.57	0.73	0.86
67°F	3200	103.1	5.2	0.42	0.51	0.6	95.6	5.88	0.39	0.49	0.59	88.1	6.62	0.36	0.47	0.58	80.3	7.51	0.33	0.45	0.57
	4000	114.4	5.25	0.43	0.54	0.65	106.6	5.93	0.41	0.53	0.64	98.5	6.68	0.39	0.51	0.64	90.3	7.54	0.37	0.5	0.64
	4800	123.3	5.31	0.45	0.57	0.69	115.2	5.98	0.44	0.56	0.69	106.6	6.73	0.42	0.55	0.69	97.6	7.59	0.39	0.54	0.7
71°F	3200	110.8	5.22	0.32	0.4	0.48	103.5	5.89	0.29	0.38	0.47	95.7	6.66	0.26	0.36	0.45	87.9	7.53	0.22	0.33	0.43
	4000	122.6	5.29	0.32	0.42	0.51	114.6	5.97	0.3	0.4	0.5	106.4	6.72	0.27	0.38	0.49	97.9	7.57	0.24	0.36	0.48
	4800	131.8	5.36	0.33	0.44	0.54	123.3	6.03	0.31	0.42	0.54	114.5	6.76	0.28	0.41	0.53	105.7	7.62	0.26	0.39	0.52

40 TON HIGH EFFICIENCY LCH480H4V (2 COMPRESSORS - FULL LOAD) - VARIABLE AIR VOLUME

Entering Wet Bulb Temperature	Total Air Volume	Outdoor Air Temperature Entering Outdoor Coil																			
		65°F					75°F					85°F					95°F				
		Total Cool Cap.	Comp. Motor Input	Sensible To Total Ratio (S/T)			Total Cool Cap.	Comp. Motor Input	Sensible To Total Ratio (S/T)			Total Cool Cap.	Comp. Motor Input	Sensible To Total Ratio (S/T)			Total Cool Cap.	Comp. Motor Input	Sensible To Total Ratio (S/T)		
				Dry Bulb					Dry Bulb					Dry Bulb					Dry Bulb		
cfm	kBtuh	kW	75°F	80°F	85°F	kBtuh	kW	75°F	80°F	85°F	kBtuh	kW	75°F	80°F	85°F	kBtuh	kW	75°F	80°F	85°F	
63°F	6400	254.3	10.67	0.64	0.78	0.91	237.2	12.03	0.64	0.78	0.92	218.3	13.49	0.64	0.79	0.94	199.4	15.2	0.63	0.79	0.96
	8000	270.2	10.8	0.69	0.83	0.98	252.4	12.14	0.69	0.85	0.98	233.7	13.61	0.69	0.85	0.99	214	15.26	0.69	0.87	1
	9600	284.3	10.94	0.73	0.89	1	265.2	12.26	0.73	0.9	1	245.2	13.7	0.73	0.92	1	225.1	15.36	0.74	0.94	1
67°F	6400	272.6	10.82	0.48	0.61	0.74	254.2	12.14	0.47	0.61	0.75	235.3	13.61	0.46	0.62	0.76	215.7	15.26	0.45	0.62	0.76
	8000	289.5	10.97	0.51	0.66	0.8	270.6	12.29	0.51	0.67	0.82	250.5	13.75	0.51	0.67	0.83	229.7	15.36	0.52	0.66	0.83
	9600	301.7	11.1	0.56	0.71	0.86	282.3	12.41	0.56	0.71	0.87	261.2	13.84	0.54	0.71	0.88	239.5	15.46	0.55	0.72	0.9
71°F	6400	290.1	10.95	0.34	0.47	0.59	270.9	12.27	0.32	0.46	0.59	252.5	13.74	0.3	0.45	0.59	232.7	15.38	0.28	0.44	0.6
	8000	307.7	11.13	0.35	0.5	0.64	288.5	12.45	0.34	0.5	0.64	267.9	13.88	0.32	0.5	0.65	246.3	15.51	0.31	0.5	0.66
	9600	321.1	11.29	0.37	0.54	0.69	299.4	12.57	0.36	0.55	0.69	278.7	14	0.35	0.54	0.69	257.5	15.63	0.35	0.53	0.7

40 TON HIGH EFFICIENCY LCH480H4V (3 COMPRESSORS - FULL LOAD) - VARIABLE AIR VOLUME

Entering Wet Bulb Temperature	Total Air Volume	Outdoor Air Temperature Entering Outdoor Coil																			
		85°F					95°F					105°F					115°F				
		Total Cool Cap.	Comp. Motor Input	Sensible To Total Ratio (S/T)			Total Cool Cap.	Comp. Motor Input	Sensible To Total Ratio (S/T)			Total Cool Cap.	Comp. Motor Input	Sensible To Total Ratio (S/T)			Total Cool Cap.	Comp. Motor Input	Sensible To Total Ratio (S/T)		
				Dry Bulb					Dry Bulb					Dry Bulb					Dry Bulb		
cfm	kBtuh	kW	75°F	80°F	85°F	kBtuh	kW	75°F	80°F	85°F	kBtuh	kW	75°F	80°F	85°F	kBtuh	kW	75°F	80°F	85°F	
63°F	9600	404	16.15	0.66	0.78	0.89	376.2	18.16	0.65	0.79	0.9	348.5	20.34	0.65	0.8	0.9	318.9	22.85	0.65	0.81	0.91
	12,000	426.6	16.33	0.7	0.84	0.92	397.9	18.32	0.7	0.85	0.93	370.2	20.54	0.7	0.86	0.94	341.6	23	0.7	0.86	0.94
	14,400	446.2	16.51	0.73	0.88	0.95	418.9	18.51	0.74	0.89	0.96	389.1	20.68	0.75	0.88	0.97	360.2	23.15	0.73	0.89	0.98
67°F	9600	429.5	16.37	0.52	0.64	0.75	402.1	18.37	0.52	0.63	0.75	372.4	20.54	0.49	0.63	0.76	342.3	23.01	0.5	0.63	0.77
	12,000	453.1	16.58	0.54	0.67	0.81	425	18.57	0.54	0.67	0.81	394.1	20.73	0.54	0.67	0.83	361.2	23.13	0.53	0.69	0.85
	14,400	471	16.77	0.56	0.7	0.86	440.5	18.72	0.56	0.72	0.87	408.5	20.86	0.56	0.73	0.88	376.8	23.32	0.56	0.74	0.87
71°F	9600	458.4	16.63	0.38	0.5	0.61	428.6	18.59	0.37	0.5	0.61	398.7	20.78	0.35	0.49	0.6	368.9	23.23	0.33	0.47	0.61
	12,000	482.3	16.89	0.4	0.53	0.65	451.4	18.83	0.38	0.52	0.65	420	20.98	0.37	0.52	0.66	387	23.4	0.37	0.52	0.66
	14,400	499.5	17.08	0.4	0.56	0.68	465.6	18.98	0.4	0.57	0.7	434.5	21.12	0.4	0.56	0.71	400.9	23.55	0.38	0.56	0.71

40 TON HIGH EFFICIENCY LCH480H4V (4 COMPRESSORS - FULL LOAD) - VARIABLE AIR VOLUME

Entering Wet Bulb Temperature	Total Air Volume	Outdoor Air Temperature Entering Outdoor Coil																			
		85°F					95°F					105°F					115°F				
		Total Cool Cap.	Comp. Motor Input	Sensible To Total Ratio (S/T)			Total Cool Cap.	Comp. Motor Input	Sensible To Total Ratio (S/T)			Total Cool Cap.	Comp. Motor Input	Sensible To Total Ratio (S/T)			Total Cool Cap.	Comp. Motor Input	Sensible To Total Ratio (S/T)		
				Dry Bulb					Dry Bulb					Dry Bulb					Dry Bulb		
cfm	kBtuh	kW	75°F	80°F	85°F	kBtuh	kW	75°F	80°F	85°F	kBtuh	kW	75°F	80°F	85°F	kBtuh	kW	75°F	80°F	85°F	
63°F	12,800	490	27.29	0.67	0.78	0.92	451.9	30.59	0.67	0.79	0.93	411.6	34.39	0.63	0.8	0.94	368.5	38.83	0.63	0.81	0.97
	16,000	520.5	27.55	0.72	0.86	0.99	480.4	30.83	0.69	0.86	0.99	437.8	34.59	0.71	0.87	1	393.2	38.94	0.72	0.9	1
	19,200	544.6	27.79	0.75	0.91	1	502.3	31.03	0.74	0.92	1	458.9	34.75	0.76	0.94	1	413.5	39.06	0.78	0.96	1
67°F	12,800	521.4	27.55	0.52	0.65	0.78	479.8	30.8	0.5	0.65	0.78	436.8	34.56	0.5	0.65	0.79	390.2	38.86	0.43	0.62	0.78
	16,000	546.7	27.8	0.56	0.7	0.84	502.4	31.02	0.51	0.71	0.85	458.1	34.74	0.48	0.69	0.84	409.4	39.03	0.48	0.7	0.86
	19,200	563.2	27.95	0.54	0.72	0.89	520	31.18	0.54	0.72	0.9	473	34.86	0.53	0.75	0.91	426.6	39.17	0.51	0.76	0.93
71°F	12,800	554.5	27.88	0.37	0.51	0.62	511.8	31.12	0.36	0.5	0.63	467.8	34.84	0.33	0.49	0.64	420.5	39.16	0.32	0.48	0.64
	16,000	579.1	28.15	0.39	0.55	0.68	535.9	31.38	0.38	0.54	0.68	487.6	35	0.31	0.49	0.7	440	39.23	0.28	0.49	0.66
	19,200	597	28.33	0.41	0.58	0.73	551	31.5	0.41	0.54	0.7	504.8	35.16	0.31	0.53	0.71	453.1	39.37	0.29	0.52	0.73

RATINGS

40 TON HIGH EFFICIENCY LCH480H4M (2 COMPRESSORS - FULL LOAD) - MSAV® (MULTI-STAGE AIR VOLUME)

Entering Wet Bulb Temperature	Total Air Volume	Outdoor Air Temperature Entering Outdoor Coil																			
		65°F					75°F					85°F					95°F				
		Total Cool Cap.	Comp. Motor Input	Sensible To Total Ratio (S/T)			Total Cool Cap.	Comp. Motor Input	Sensible To Total Ratio (S/T)			Total Cool Cap.	Comp. Motor Input	Sensible To Total Ratio (S/T)			Total Cool Cap.	Comp. Motor Input	Sensible To Total Ratio (S/T)		
				Dry Bulb					Dry Bulb					Dry Bulb					Dry Bulb		
cfm	kBtuh	kW	75°F	80°F	85°F	kBtuh	kW	75°F	80°F	85°F	kBtuh	kW	75°F	80°F	85°F	kBtuh	kW	75°F	80°F	85°F	
63°F	6400	261.5	11.25	0.67	0.80	0.93	247.5	12.60	0.68	0.81	0.95	232.6	14.09	0.68	0.83	0.96	217.5	15.79	0.69	0.84	0.98
	8000	276.8	11.42	0.72	0.87	0.99	261.9	12.77	0.72	0.88	1.00	246.5	14.27	0.73	0.90	1.00	230.0	15.94	0.73	0.92	1.00
	9600	288.2	11.56	0.76	0.92	1.00	272.7	12.90	0.76	0.94	1.00	255.8	14.38	0.77	0.96	1.00	239.4	16.06	0.79	0.97	1.00
67°F	6400	275.9	11.41	0.53	0.67	0.77	261.7	12.76	0.55	0.66	0.78	246.9	14.27	0.52	0.66	0.79	231.2	15.96	0.52	0.67	0.81
	8000	292.5	11.61	0.55	0.69	0.83	277.4	12.96	0.55	0.70	0.85	261.1	14.45	0.55	0.71	0.87	244.6	16.13	0.56	0.72	0.89
	9600	304.8	11.78	0.58	0.74	0.89	288.4	13.11	0.58	0.75	0.91	271.8	14.60	0.58	0.76	0.93	254.0	16.26	0.59	0.77	0.95
71°F	6400	290.0	11.58	0.43	0.54	0.65	275.0	12.92	0.43	0.54	0.63	259.7	14.42	0.42	0.54	0.64	244.2	16.12	0.41	0.51	0.64
	8000	307.8	11.81	0.44	0.55	0.69	291.8	13.15	0.44	0.54	0.68	275.0	14.62	0.39	0.55	0.69	258.0	16.31	0.39	0.55	0.70
	9600	320.0	11.98	0.42	0.57	0.71	303.3	13.30	0.41	0.57	0.73	286.5	14.80	0.41	0.58	0.73	268.2	16.46	0.40	0.58	0.74

40 TON HIGH EFFICIENCY LCH480H4M (4 COMPRESSORS - FULL LOAD) - MSAV® (MULTI-STAGE AIR VOLUME)

Entering Wet Bulb Temperature	Total Air Volume	Outdoor Air Temperature Entering Outdoor Coil																			
		85°F					95°F					105°F					115°F				
		Total Cool Cap.	Comp. Motor Input	Sensible To Total Ratio (S/T)			Total Cool Cap.	Comp. Motor Input	Sensible To Total Ratio (S/T)			Total Cool Cap.	Comp. Motor Input	Sensible To Total Ratio (S/T)			Total Cool Cap.	Comp. Motor Input	Sensible To Total Ratio (S/T)		
				Dry Bulb					Dry Bulb					Dry Bulb					Dry Bulb		
cfm	kBtuh	kW	75°F	80°F	85°F	kBtuh	kW	75°F	80°F	85°F	kBtuh	kW	75°F	80°F	85°F	kBtuh	kW	75°F	80°F	85°F	
63°F	12,800	490.0	27.29	0.67	0.78	0.92	451.9	30.59	0.67	0.79	0.93	411.6	34.39	0.63	0.80	0.94	368.5	38.83	0.63	0.81	0.97
	16,000	520.5	27.55	0.72	0.86	0.99	480.4	30.83	0.69	0.86	0.99	437.8	34.59	0.71	0.87	1.00	393.2	38.94	0.72	0.90	1.00
	19,200	544.6	27.79	0.75	0.91	1.00	502.3	31.03	0.74	0.92	1.00	458.9	34.75	0.76	0.94	1.00	413.5	39.06	0.78	0.96	1.00
67°F	12,800	521.4	27.55	0.52	0.65	0.78	479.8	30.80	0.50	0.65	0.78	436.8	34.56	0.50	0.65	0.79	390.2	38.86	0.43	0.62	0.78
	16,000	546.7	27.80	0.56	0.70	0.84	502.4	31.02	0.51	0.71	0.85	458.1	34.74	0.48	0.69	0.84	409.4	39.03	0.48	0.70	0.86
	19,200	563.2	27.95	0.54	0.72	0.89	520.0	31.18	0.54	0.72	0.90	473.0	34.86	0.53	0.75	0.91	426.6	39.17	0.51	0.76	0.93
71°F	12,800	554.5	27.88	0.37	0.51	0.62	511.8	31.12	0.36	0.50	0.63	467.8	34.84	0.33	0.49	0.64	420.5	39.16	0.32	0.48	0.64
	16,000	579.1	28.15	0.39	0.55	0.68	535.9	31.38	0.38	0.54	0.68	487.6	35.00	0.31	0.49	0.70	440.0	39.23	0.28	0.49	0.66
	19,200	597.0	28.33	0.41	0.58	0.73	551.0	31.50	0.41	0.54	0.70	504.8	35.16	0.31	0.53	0.71	453.1	39.37	0.29	0.52	0.73

RATINGS

45 TON STANDARD EFFICIENCY LCH540S4V (1 COMPRESSOR - FULL LOAD) - VARIABLE AIR VOLUME

Entering Wet Bulb Temperature	Total Air Volume	Outdoor Air Temperature Entering Outdoor Coil																			
		65°F					75°F					85°F					95°F				
		Total Cool Cap.	Comp. Motor Input	Sensible To Total Ratio (S/T)			Total Cool Cap.	Comp. Motor Input	Sensible To Total Ratio (S/T)			Total Cool Cap.	Comp. Motor Input	Sensible To Total Ratio (S/T)			Total Cool Cap.	Comp. Motor Input	Sensible To Total Ratio (S/T)		
				Dry Bulb					Dry Bulb					Dry Bulb					Dry Bulb		
cfm	kBtuh	kW	75°F	80°F	85°F	kBtuh	kW	75°F	80°F	85°F	kBtuh	kW	75°F	80°F	85°F	kBtuh	kW	75°F	80°F	85°F	
63°F	3600	112.7	6.51	0.57	0.63	0.73	107.5	7.09	0.53	0.63	0.76	101.8	7.87	0.52	0.67	0.77	96.3	8.82	0.57	0.67	0.78
	4500	121.2	6.61	0.59	0.69	0.79	116.3	7.21	0.59	0.7	0.8	110.8	7.98	0.59	0.7	0.82	105.1	8.94	0.59	0.71	0.83
	5400	128.8	6.7	0.61	0.72	0.83	123.6	7.3	0.61	0.73	0.85	118	8.09	0.61	0.74	0.86	111.5	9.03	0.62	0.75	0.88
67°F	3600	116.8	6.56	0.46	0.59	0.63	112.1	7.15	0.51	0.59	0.63	107.3	7.93	0.45	0.54	0.63	101.9	8.9	0.5	0.54	0.64
	4500	127.3	6.68	0.46	0.56	0.66	122.4	7.28	0.46	0.56	0.66	116.9	8.07	0.46	0.56	0.67	110.9	9.03	0.45	0.56	0.67
	5400	135.2	6.77	0.47	0.58	0.69	130.1	7.38	0.47	0.58	0.69	124.3	8.17	0.47	0.58	0.7	117.5	9.12	0.47	0.59	0.72
71°F	3600	122.1	6.62	0.42	0.49	0.56	117.5	7.22	0.41	0.49	0.56	112.3	8	0.41	0.49	0.56	106.8	8.97	0.4	0.48	0.51
	4500	132.8	6.74	0.42	0.5	0.53	127.9	7.35	0.42	0.5	0.53	122.6	8.14	0.41	0.44	0.53	116.5	9.1	0.41	0.44	0.54
	5400	141.4	6.83	0.42	0.45	0.55	136.1	7.45	0.35	0.45	0.55	130.2	8.25	0.34	0.45	0.56	123.7	9.21	0.33	0.45	0.56

45 TON STANDARD EFFICIENCY LCH540S4V (2 COMPRESSORS - FULL LOAD) - VARIABLE AIR VOLUME

Entering Wet Bulb Temperature	Total Air Volume	Outdoor Air Temperature Entering Outdoor Coil																			
		65°F					75°F					85°F					95°F				
		Total Cool Cap.	Comp. Motor Input	Sensible To Total Ratio (S/T)			Total Cool Cap.	Comp. Motor Input	Sensible To Total Ratio (S/T)			Total Cool Cap.	Comp. Motor Input	Sensible To Total Ratio (S/T)			Total Cool Cap.	Comp. Motor Input	Sensible To Total Ratio (S/T)		
				Dry Bulb					Dry Bulb					Dry Bulb					Dry Bulb		
cfm	kBtuh	kW	75°F	80°F	85°F	kBtuh	kW	75°F	80°F	85°F	kBtuh	kW	75°F	80°F	85°F	kBtuh	kW	75°F	80°F	85°F	
63°F	7200	279	13.63	0.64	0.78	0.91	268	14.86	0.65	0.79	0.92	255.6	16.45	0.66	0.8	0.94	241.1	18.33	0.67	0.82	0.96
	9000	293.7	13.78	0.68	0.84	0.97	282.6	15.05	0.69	0.85	0.98	269.3	16.64	0.7	0.87	0.99	253.9	18.55	0.72	0.89	1
	10,800	304.7	13.9	0.73	0.9	1	292.5	15.17	0.74	0.91	1	278.6	16.77	0.75	0.93	1	262.3	18.68	0.77	0.95	1
67°F	7200	293	13.77	0.49	0.62	0.74	282	15.04	0.5	0.62	0.75	268.8	16.62	0.5	0.63	0.77	254.9	18.56	0.5	0.64	0.79
	9000	308.6	13.94	0.52	0.66	0.81	296.8	15.23	0.52	0.67	0.82	283.3	16.84	0.53	0.68	0.84	267.6	18.75	0.53	0.69	0.86
	10,800	320.2	14.06	0.54	0.7	0.86	307.2	15.36	0.55	0.72	0.88	293.1	16.98	0.55	0.73	0.9	277.2	18.91	0.56	0.75	0.92
71°F	7200	306.3	13.91	0.35	0.48	0.6	295	15.19	0.35	0.48	0.6	281.9	16.8	0.35	0.48	0.61	267.4	18.74	0.34	0.48	0.62
	9000	322.1	14.07	0.36	0.5	0.64	310.4	15.4	0.36	0.51	0.65	296.4	17.02	0.36	0.51	0.66	280.6	18.95	0.35	0.52	0.67
	10,800	333.6	14.19	0.37	0.53	0.68	321.5	15.54	0.37	0.54	0.69	306.6	17.17	0.36	0.54	0.71	291.5	19.16	0.36	0.55	0.72

45 TON STANDARD EFFICIENCY LCH540S4V (3 COMPRESSORS - FULL LOAD) - VARIABLE AIR VOLUME

Entering Wet Bulb Temperature	Total Air Volume	Outdoor Air Temperature Entering Outdoor Coil																			
		85°F					95°F					105°F					115°F				
		Total Cool Cap.	Comp. Motor Input	Sensible To Total Ratio (S/T)			Total Cool Cap.	Comp. Motor Input	Sensible To Total Ratio (S/T)			Total Cool Cap.	Comp. Motor Input	Sensible To Total Ratio (S/T)			Total Cool Cap.	Comp. Motor Input	Sensible To Total Ratio (S/T)		
				Dry Bulb					Dry Bulb					Dry Bulb					Dry Bulb		
cfm	kBtuh	kW	75°F	80°F	85°F	kBtuh	kW	75°F	80°F	85°F	kBtuh	kW	75°F	80°F	85°F	kBtuh	kW	75°F	80°F	85°F	
63°F	10,800	431.3	20.54	0.65	0.78	0.89	414.1	22.41	0.66	0.79	0.89	394.3	24.78	0.67	0.8	0.9	371.8	27.64	0.67	0.82	0.91
	13,500	451.6	20.77	0.69	0.84	0.92	433.3	22.65	0.7	0.84	0.93	413.4	25.06	0.71	0.86	0.94	392.3	27.98	0.73	0.87	0.95
	16,200	468.5	20.94	0.73	0.88	0.95	450.7	22.88	0.74	0.89	0.96	431.3	25.33	0.76	0.9	0.97	409.1	28.24	0.77	0.91	0.98
67°F	10,800	454.8	20.8	0.51	0.63	0.75	436.5	22.69	0.51	0.63	0.75	416.9	25.11	0.51	0.64	0.76	394.3	28	0.52	0.65	0.78
	13,500	475.1	21.01	0.53	0.67	0.81	456.5	22.95	0.54	0.67	0.82	435.1	25.37	0.54	0.68	0.83	411.6	28.27	0.56	0.7	0.84
	16,200	489.8	21.16	0.56	0.7	0.85	470.7	23.13	0.56	0.72	0.86	449.3	25.6	0.58	0.74	0.88	424.3	28.49	0.59	0.76	0.89
71°F	10,800	477.4	21.03	0.38	0.5	0.61	459.4	22.99	0.38	0.5	0.61	438.6	25.42	0.37	0.5	0.62	416.7	28.36	0.37	0.5	0.62
	13,500	499.3	21.26	0.38	0.52	0.64	479.7	23.25	0.38	0.52	0.65	458.4	25.72	0.37	0.52	0.66	433.5	28.63	0.38	0.53	0.67
	16,200	513.3	21.4	0.39	0.55	0.69	493.8	23.42	0.38	0.55	0.69	471.5	25.91	0.39	0.56	0.71	444.8	28.81	0.39	0.58	0.73

45 TON STANDARD EFFICIENCY LCH540S4V (4 COMPRESSORS - FULL LOAD) - VARIABLE AIR VOLUME

Entering Wet Bulb Temperature	Total Air Volume	Outdoor Air Temperature Entering Outdoor Coil																			
		85°F					95°F					105°F					115°F				
		Total Cool Cap.	Comp. Motor Input	Sensible To Total Ratio (S/T)			Total Cool Cap.	Comp. Motor Input	Sensible To Total Ratio (S/T)			Total Cool Cap.	Comp. Motor Input	Sensible To Total Ratio (S/T)			Total Cool Cap.	Comp. Motor Input	Sensible To Total Ratio (S/T)		
				Dry Bulb					Dry Bulb					Dry Bulb					Dry Bulb		
cfm	kBtuh	kW	75°F	80°F	85°F	kBtuh	kW	75°F	80°F	85°F	kBtuh	kW	75°F	80°F	85°F	kBtuh	kW	75°F	80°F	85°F	
63°F	14,400	546.3	33.32	0.67	0.8	0.92	516.9	37.17	0.69	0.82	0.94	485.7	41.66	0.7	0.84	0.96	452.7	46.84	0.72	0.86	0.99
	18,000	574.1	33.73	0.73	0.87	0.99	544.4	37.63	0.74	0.89	0.99	510	42.09	0.78	0.91	1	474.6	47.18	0.78	0.93	1
	21,600	594.4	34.03	0.79	0.92	1	562.9	37.92	0.78	0.94	1	528.9	42.42	0.82	0.96	1	491.2	47.49	0.84	0.99	1
67°F	14,400	573.9	33.72	0.52	0.65	0.77	542.5	37.58	0.52	0.67	0.79	508	42.04	0.54	0.67	0.82	471.9	47.17	0.54	0.69	0.84
	18,000	596	34.05	0.56	0.71	0.85	563.1	37.91	0.56	0.72	0.86	527.5	42.39	0.57	0.73	0.88	489.4	47.43	0.58	0.77	0.9
	21,600	611.9	34.3	0.58	0.75	0.9	578.8	38.18	0.6	0.77	0.92	542.6	42.62	0.59	0.79	0.94	504.1	47.71	0.6	0.82	0.96
71°F	14,400	604.9	34.18	0.37	0.5	0.61	572.7	38.07	0.38	0.51	0.63	537.7	42.56	0.39	0.52	0.66	499.4	47.62	0.38	0.53	0.66
	18,000	626.2	34.49	0.38	0.55	0.68	593	38.42	0.4	0.55	0.7	555.1	42.87	0.39	0.56	0.71	517.4	47.95	0.39	0.56	0.72
	21,600	643.2	34.76	0.41	0.58	0.74	608.2	38.67	0.38	0.59	0.74	571.9	43.21	0.39	0.6	0.77	528.5	48.17	0.42	0.62	0.79

RATINGS

45 TON STANDARD EFFICIENCY LCH540S4M (2 COMPRESSORS - FULL LOAD) - MSAV® (MULTI-STAGE AIR VOLUME)

Entering Wet Bulb Temperature	Total Air Volume	Outdoor Air Temperature Entering Outdoor Coil																			
		65°F					75°F					85°F					95°F				
		Total Cool Cap.	Comp. Motor Input	Sensible To Total Ratio (S/T)			Total Cool Cap.	Comp. Motor Input	Sensible To Total Ratio (S/T)			Total Cool Cap.	Comp. Motor Input	Sensible To Total Ratio (S/T)			Total Cool Cap.	Comp. Motor Input	Sensible To Total Ratio (S/T)		
				Dry Bulb					Dry Bulb					Dry Bulb					Dry Bulb		
cfm	kBtuh	kW	75°F	80°F	85°F	kBtuh	kW	75°F	80°F	85°F	kBtuh	kW	75°F	80°F	85°F	kBtuh	kW	75°F	80°F	85°F	
63°F	7200	297.8	14.32	0.69	0.81	0.93	282.7	15.73	0.69	0.82	0.95	266.1	17.49	0.69	0.83	0.96	248.3	19.53	0.70	0.85	0.98
	9000	314.4	14.52	0.72	0.87	0.98	298.7	15.96	0.73	0.88	1.00	281.1	17.72	0.74	0.90	1.00	262.2	19.80	0.75	0.92	1.00
	10800	326.6	14.67	0.76	0.92	1.00	310.3	16.13	0.77	0.94	1.00	291.7	17.89	0.79	0.95	1.00	272.7	19.98	0.80	0.97	1.00
67°F	7200	313.2	14.50	0.55	0.67	0.78	298.0	15.95	0.55	0.67	0.79	280.9	17.71	0.55	0.68	0.80	262.9	19.81	0.55	0.68	0.82
	9000	330.7	14.72	0.58	0.71	0.84	314.4	16.19	0.58	0.71	0.85	296.8	17.98	0.58	0.72	0.87	277.5	20.07	0.58	0.73	0.89
	10800	343.3	14.87	0.60	0.75	0.89	326.8	16.37	0.60	0.75	0.91	308.0	18.18	0.61	0.77	0.93	287.5	20.27	0.61	0.78	0.95
71°F	7200	327.6	14.67	0.43	0.54	0.65	312.3	16.15	0.43	0.54	0.65	295.0	17.93	0.42	0.54	0.66	276.3	20.03	0.41	0.54	0.66
	9000	345.7	14.89	0.44	0.57	0.69	329.4	16.40	0.44	0.57	0.69	310.9	18.21	0.43	0.57	0.70	291.4	20.31	0.43	0.57	0.71
	10800	358.6	15.05	0.46	0.59	0.73	341.6	16.58	0.45	0.60	0.74	323.0	18.42	0.45	0.60	0.75	302.5	20.54	0.44	0.60	0.77

45 TON STANDARD EFFICIENCY LCH540S4M (4 COMPRESSORS - FULL LOAD) - MSAV® (MULTI-STAGE AIR VOLUME)

Entering Wet Bulb Temperature	Total Air Volume	Outdoor Air Temperature Entering Outdoor Coil																			
		85°F					95°F					105°F					115°F				
		Total Cool Cap.	Comp. Motor Input	Sensible To Total Ratio (S/T)			Total Cool Cap.	Comp. Motor Input	Sensible To Total Ratio (S/T)			Total Cool Cap.	Comp. Motor Input	Sensible To Total Ratio (S/T)			Total Cool Cap.	Comp. Motor Input	Sensible To Total Ratio (S/T)		
				Dry Bulb					Dry Bulb					Dry Bulb					Dry Bulb		
cfm	kBtuh	kW	75°F	80°F	85°F	kBtuh	kW	75°F	80°F	85°F	kBtuh	kW	75°F	80°F	85°F	kBtuh	kW	75°F	80°F	85°F	
63°F	14,400	546.3	33.32	0.67	0.80	0.92	516.9	37.17	0.69	0.82	0.94	485.7	41.66	0.70	0.84	0.96	452.7	46.84	0.72	0.86	0.99
	18,000	574.1	33.73	0.73	0.87	0.99	544.4	37.63	0.74	0.89	0.99	510.0	42.09	0.78	0.91	1.00	474.6	47.18	0.78	0.93	1.00
	21,600	594.4	34.03	0.79	0.92	1.00	562.9	37.92	0.78	0.94	1.00	528.9	42.42	0.82	0.96	1.00	491.2	47.49	0.84	0.99	1.00
67°F	14,400	573.9	33.72	0.52	0.65	0.77	542.5	37.58	0.52	0.67	0.79	508.0	42.04	0.54	0.67	0.82	471.9	47.17	0.54	0.69	0.84
	18,000	596.0	34.05	0.56	0.71	0.85	563.1	37.91	0.56	0.72	0.86	527.5	42.39	0.57	0.73	0.88	489.4	47.43	0.58	0.77	0.90
	21,600	611.9	34.30	0.58	0.75	0.90	578.8	38.18	0.60	0.77	0.92	542.6	42.62	0.59	0.79	0.94	504.1	47.71	0.60	0.82	0.96
71°F	14,400	604.9	34.18	0.37	0.50	0.61	572.7	38.07	0.38	0.51	0.63	537.7	42.56	0.39	0.52	0.66	499.4	47.62	0.38	0.53	0.66
	18,000	626.2	34.49	0.38	0.55	0.68	593.0	38.42	0.40	0.55	0.70	555.1	42.87	0.39	0.56	0.71	517.4	47.95	0.39	0.56	0.72
	21,600	643.2	34.76	0.41	0.58	0.74	608.2	38.67	0.38	0.59	0.74	571.9	43.21	0.39	0.60	0.77	528.5	48.17	0.42	0.62	0.79

RATINGS

50 TON STANDARD EFFICIENCY LCH600S4V (1 COMPRESSOR - FULL LOAD) - VARIABLE AIR VOLUME

Entering Wet Bulb Temperature	Total Air Volume	Outdoor Air Temperature Entering Outdoor Coil																			
		65°F					75°F					85°F					95°F				
		Total Cool Cap.	Comp. Motor Input	Sensible To Total Ratio (S/T)			Total Cool Cap.	Comp. Motor Input	Sensible To Total Ratio (S/T)			Total Cool Cap.	Comp. Motor Input	Sensible To Total Ratio (S/T)			Total Cool Cap.	Comp. Motor Input	Sensible To Total Ratio (S/T)		
				Dry Bulb					Dry Bulb					Dry Bulb					Dry Bulb		
cfm	kBtuh	kW	75°F	80°F	85°F	kBtuh	kW	75°F	80°F	85°F	kBtuh	kW	75°F	80°F	85°F	kBtuh	kW	75°F	80°F	85°F	
63°F	4000	123.4	7	0.53	0.63	0.74	118	7.79	0.53	0.67	0.78	113.1	8.69	0.58	0.68	0.78	106.4	9.68	0.58	0.69	0.79
	5000	132.5	7.13	0.58	0.69	0.8	127.1	7.91	0.59	0.7	0.81	121.4	8.8	0.6	0.71	0.82	115.3	9.83	0.62	0.73	0.84
	6000	140.7	7.23	0.61	0.73	0.83	134.4	8.01	0.61	0.74	0.84	128.1	8.9	0.63	0.75	0.86	121.6	9.92	0.65	0.76	0.87
67°F	4000	129.4	7.08	0.4	0.54	0.62	123.5	7.86	0.46	0.54	0.63	118.5	8.76	0.45	0.54	0.63	113.2	9.79	0.44	0.54	0.64
	5000	139.4	7.21	0.46	0.56	0.65	134	8	0.46	0.56	0.66	128.5	8.91	0.46	0.56	0.68	122	9.92	0.46	0.57	0.69
	6000	148	7.33	0.47	0.57	0.69	142.1	8.12	0.47	0.58	0.7	135.1	9	0.47	0.61	0.72	128.8	10.02	0.5	0.62	0.73
71°F	4000	134.4	7.14	0.35	0.43	0.51	129.7	7.94	0.34	0.43	0.51	124.2	8.83	0.34	0.42	0.51	118.8	9.87	0.33	0.42	0.51
	5000	146.1	7.3	0.34	0.44	0.53	140.4	8.09	0.34	0.44	0.53	134.6	8.99	0.34	0.44	0.53	128.3	10.01	0.33	0.44	0.54
	6000	154.9	7.42	0.34	0.44	0.55	148.9	8.21	0.34	0.45	0.55	142.4	9.11	0.33	0.45	0.56	135.3	10.12	0.33	0.46	0.59

50 TON STANDARD EFFICIENCY LCH600S4V (2 COMPRESSORS - FULL LOAD) - VARIABLE AIR VOLUME

Entering Wet Bulb Temperature	Total Air Volume	Outdoor Air Temperature Entering Outdoor Coil																			
		65°F					75°F					85°F					95°F				
		Total Cool Cap.	Comp. Motor Input	Sensible To Total Ratio (S/T)			Total Cool Cap.	Comp. Motor Input	Sensible To Total Ratio (S/T)			Total Cool Cap.	Comp. Motor Input	Sensible To Total Ratio (S/T)			Total Cool Cap.	Comp. Motor Input	Sensible To Total Ratio (S/T)		
				Dry Bulb					Dry Bulb					Dry Bulb					Dry Bulb		
cfm	kBtuh	kW	75°F	80°F	85°F	kBtuh	kW	75°F	80°F	85°F	kBtuh	kW	75°F	80°F	85°F	kBtuh	kW	75°F	80°F	85°F	
63°F	8000	306.5	14.83	0.65	0.77	0.9	291.7	16.39	0.65	0.78	0.91	279.1	18.21	0.67	0.8	0.93	263.7	20.26	0.68	0.81	0.95
	10,000	322	15.04	0.68	0.82	0.96	308.2	16.62	0.68	0.83	0.98	293.5	18.43	0.7	0.85	0.98	278	20.47	0.72	0.87	0.99
	12,000	334.2	15.2	0.71	0.87	0.99	320	16.79	0.72	0.89	1	304.1	18.57	0.74	0.91	1	288.4	20.63	0.75	0.92	1
67°F	8000	321.9	15.03	0.49	0.62	0.74	308.8	16.62	0.5	0.63	0.75	294.9	18.45	0.51	0.64	0.76	278.7	20.48	0.53	0.66	0.78
	10,000	339.6	15.28	0.52	0.66	0.79	323.8	16.84	0.54	0.67	0.8	307.5	18.62	0.54	0.68	0.82	292.3	20.68	0.56	0.69	0.84
	12,000	350.3	15.43	0.56	0.69	0.84	335.2	17.01	0.55	0.7	0.85	318.1	18.79	0.58	0.72	0.87	301.3	20.82	0.59	0.73	0.89
71°F	8000	337.7	15.25	0.35	0.47	0.59	323.5	16.83	0.35	0.48	0.6	308.6	18.63	0.35	0.5	0.62	293.7	20.71	0.35	0.51	0.63
	10,000	355	15.49	0.36	0.5	0.63	340.2	17.08	0.36	0.51	0.65	324	18.88	0.38	0.53	0.66	307.4	20.92	0.38	0.53	0.66
	12,000	367.8	15.68	0.37	0.54	0.67	351.1	17.25	0.4	0.55	0.68	334.5	19.04	0.39	0.56	0.69	317.5	21.09	0.4	0.57	0.71

50 TON STANDARD EFFICIENCY LCH600S4V (3 COMPRESSORS - FULL LOAD) - VARIABLE AIR VOLUME

Entering Wet Bulb Temperature	Total Air Volume	Outdoor Air Temperature Entering Outdoor Coil																			
		85°F					95°F					105°F					115°F				
		Total Cool Cap.	Comp. Motor Input	Sensible To Total Ratio (S/T)			Total Cool Cap.	Comp. Motor Input	Sensible To Total Ratio (S/T)			Total Cool Cap.	Comp. Motor Input	Sensible To Total Ratio (S/T)			Total Cool Cap.	Comp. Motor Input	Sensible To Total Ratio (S/T)		
				Dry Bulb					Dry Bulb					Dry Bulb					Dry Bulb		
cfm	kBtuh	kW	75°F	80°F	85°F	kBtuh	kW	75°F	80°F	85°F	kBtuh	kW	75°F	80°F	85°F	kBtuh	kW	75°F	80°F	85°F	
63°F	12,000	473.5	22.44	0.65	0.78	0.89	454.1	24.86	0.66	0.79	0.9	432.1	27.59	0.67	0.8	0.9	410.3	30.71	0.68	0.82	0.91
	15,000	497.7	22.77	0.68	0.84	0.92	473.7	25.12	0.69	0.84	0.93	452.6	27.87	0.7	0.86	0.94	430.5	31.02	0.69	0.88	0.95
	18,000	515.9	23.01	0.72	0.88	0.95	494	25.41	0.73	0.88	0.96	472.5	28.17	0.75	0.9	0.97	448.4	31.26	0.74	0.91	0.98
67°F	12,000	500.7	22.81	0.51	0.62	0.73	479.3	25.2	0.52	0.63	0.75	455.2	27.91	0.53	0.64	0.77	432.1	31.03	0.53	0.65	0.78
	15,000	522.4	23.1	0.54	0.67	0.8	499.3	25.47	0.55	0.67	0.82	476.8	28.21	0.55	0.68	0.83	451.2	31.31	0.56	0.69	0.85
	18,000	539.9	23.36	0.56	0.7	0.85	517.1	25.75	0.57	0.71	0.87	491.2	28.44	0.58	0.73	0.87	465.4	31.53	0.59	0.74	0.89
71°F	12,000	527.1	23.18	0.37	0.49	0.6	504.7	25.57	0.37	0.49	0.61	480.4	28.27	0.38	0.52	0.62	456	31.38	0.39	0.52	0.63
	15,000	550.6	23.5	0.38	0.51	0.63	526.4	25.88	0.41	0.53	0.65	502.6	28.62	0.4	0.54	0.67	475.6	31.7	0.4	0.55	0.67
	18,000	567.7	23.75	0.41	0.55	0.68	542.2	26.12	0.41	0.55	0.69	515.6	28.82	0.41	0.56	0.7	488.7	31.89	0.42	0.57	0.72

50 TON STANDARD EFFICIENCY LCH600S4V (4 COMPRESSORS - FULL LOAD) - VARIABLE AIR VOLUME

Entering Wet Bulb Temperature	Total Air Volume	Outdoor Air Temperature Entering Outdoor Coil																			
		85°F					95°F					105°F					115°F				
		Total Cool Cap.	Comp. Motor Input	Sensible To Total Ratio (S/T)			Total Cool Cap.	Comp. Motor Input	Sensible To Total Ratio (S/T)			Total Cool Cap.	Comp. Motor Input	Sensible To Total Ratio (S/T)			Total Cool Cap.	Comp. Motor Input	Sensible To Total Ratio (S/T)		
				Dry Bulb					Dry Bulb					Dry Bulb					Dry Bulb		
cfm	kBtuh	kW	75°F	80°F	85°F	kBtuh	kW	75°F	80°F	85°F	kBtuh	kW	75°F	80°F	85°F	kBtuh	kW	75°F	80°F	85°F	
63°F	16,000	600.3	37.1	0.67	0.82	0.92	570.5	41.29	0.67	0.82	0.93	538.4	46.03	0.68	0.83	0.95	504.3	51.45	0.7	0.85	0.97
	20,000	630.4	37.55	0.7	0.87	0.98	598.4	41.69	0.72	0.88	0.99	564.7	46.41	0.73	0.89	1	529	51.84	0.76	0.92	1
	24,000	653	37.89	0.74	0.91	1	620.3	42.03	0.78	0.93	1	585.2	46.73	0.78	0.95	1	546.9	52.11	0.82	0.97	1
67°F	16,000	630.6	37.53	0.53	0.65	0.78	597.7	41.65	0.54	0.66	0.79	563.2	46.39	0.51	0.65	0.81	525.3	51.77	0.53	0.68	0.82
	20,000	656.4	37.94	0.56	0.69	0.84	621.1	42.02	0.54	0.69	0.86	585.7	46.76	0.56	0.71	0.86	544.9	52.06	0.56	0.73	0.89
	24,000	674.5	38.23	0.58	0.72	0.89	638.3	42.31	0.56	0.75	0.9	600.6	46.98	0.58	0.76	0.92	560.6	52.29	0.59	0.81	0.95
71°F	16,000	664.7	38.07	0.39	0.51	0.62	630.1	42.19	0.4	0.52	0.63	594	46.89	0.39	0.53	0.63	554.3	52.21	0.36	0.51	0.65
	20,000	688.9	38.45	0.4	0.54	0.67	652.2	42.53	0.41	0.56	0.69	614.8	47.24	0.38	0.53	0.69	573.7	52.53	0.38	0.56	0.72
	24,000	706.6	38.74	0.42	0.58	0.72	669.1	42.83	0.39	0.56	0.75	629.8	47.49	0.39	0.57	0.74	587.1	52.74	0.4	0.59	0.77

RATINGS

50 TON STANDARD EFFICIENCY LCH600S4M (2 COMPRESSORS - FULL LOAD) - MSAV® (MULTI-STAGE AIR VOLUME)

Entering Wet Bulb Temperature	Total Air Volume	Outdoor Air Temperature Entering Outdoor Coil																			
		65°F					75°F					85°F					95°F				
		Total Cool Cap.	Comp. Motor Input	Sensible To Total Ratio (S/T) Dry Bulb			Total Cool Cap.	Comp. Motor Input	Sensible To Total Ratio (S/T) Dry Bulb			Total Cool Cap.	Comp. Motor Input	Sensible To Total Ratio (S/T) Dry Bulb			Total Cool Cap.	Comp. Motor Input	Sensible To Total Ratio (S/T) Dry Bulb		
				75°F	80°F	85°F			75°F	80°F	85°F			75°F	80°F	85°F			75°F	80°F	85°F
cfm	kBtuh	kW	75°F	80°F	85°F	kBtuh	kW	75°F	80°F	85°F	kBtuh	kW	75°F	80°F	85°F	kBtuh	kW	75°F	80°F	85°F	
63°F	8000	333.2	16.06	0.68	0.80	0.92	316.1	17.86	0.69	0.81	0.94	298.6	19.94	0.69	0.82	0.95	280.2	22.31	0.70	0.84	0.97
	10,000	352.3	16.31	0.72	0.86	0.97	334.8	18.12	0.73	0.87	0.99	316.0	20.19	0.73	0.89	0.99	296.6	22.56	0.73	0.90	1.00
	12,000	366.7	16.50	0.75	0.91	1.00	347.7	18.32	0.76	0.92	1.00	328.5	20.37	0.76	0.94	1.00	308.0	22.75	0.78	0.96	1.00
67°F	8000	350.6	16.28	0.55	0.66	0.77	333.7	18.12	0.55	0.67	0.78	315.4	20.19	0.55	0.67	0.79	297.2	22.57	0.55	0.68	0.81
	10,000	371.4	16.58	0.57	0.70	0.82	352.9	18.39	0.57	0.71	0.84	333.9	20.45	0.58	0.70	0.85	314.3	22.85	0.58	0.72	0.87
	12,000	386.8	16.82	0.60	0.73	0.88	367.0	18.61	0.57	0.74	0.89	347.5	20.70	0.60	0.76	0.91	326.6	23.07	0.58	0.76	0.93
71°F	8000	367.4	16.52	0.44	0.54	0.64	350.0	18.35	0.43	0.54	0.65	332.0	20.42	0.42	0.54	0.65	312.8	22.82	0.42	0.54	0.66
	10,000	389.2	16.84	0.44	0.56	0.68	370.5	18.66	0.44	0.56	0.69	351.0	20.74	0.43	0.57	0.69	330.7	23.11	0.43	0.57	0.70
	12,000	404.7	17.07	0.45	0.59	0.71	385.5	18.91	0.45	0.59	0.72	365.1	20.99	0.44	0.59	0.74	344.1	23.35	0.40	0.57	0.74

50 TON STANDARD EFFICIENCY LCH600S4M (4 COMPRESSORS - FULL LOAD) - MSAV® (MULTI-STAGE AIR VOLUME)

Entering Wet Bulb Temperature	Total Air Volume	Outdoor Air Temperature Entering Outdoor Coil																			
		85°F					95°F					105°F					115°F				
		Total Cool Cap.	Comp. Motor Input	Sensible To Total Ratio (S/T) Dry Bulb			Total Cool Cap.	Comp. Motor Input	Sensible To Total Ratio (S/T) Dry Bulb			Total Cool Cap.	Comp. Motor Input	Sensible To Total Ratio (S/T) Dry Bulb			Total Cool Cap.	Comp. Motor Input	Sensible To Total Ratio (S/T) Dry Bulb		
				75°F	80°F	85°F			75°F	80°F	85°F			75°F	80°F	85°F			75°F	80°F	85°F
cfm	kBtuh	kW	75°F	80°F	85°F	kBtuh	kW	75°F	80°F	85°F	kBtuh	kW	75°F	80°F	85°F	kBtuh	kW	75°F	80°F	85°F	
63°F	16,000	600.3	37.10	0.67	0.82	0.92	570.5	41.29	0.67	0.82	0.93	538.4	46.03	0.68	0.83	0.95	504.3	51.45	0.70	0.85	0.97
	20,000	630.4	37.55	0.70	0.87	0.98	598.4	41.69	0.72	0.88	0.99	564.7	46.41	0.73	0.89	1.00	529.0	51.84	0.76	0.92	1.00
	24,000	653.0	37.89	0.74	0.91	1.00	620.3	42.03	0.78	0.93	1.00	585.2	46.73	0.78	0.95	1.00	546.9	52.11	0.82	0.97	1.00
67°F	16,000	630.6	37.53	0.53	0.65	0.78	597.7	41.65	0.54	0.66	0.79	563.2	46.39	0.51	0.65	0.81	525.3	51.77	0.53	0.68	0.82
	20,000	656.4	37.94	0.56	0.69	0.84	621.1	42.02	0.54	0.69	0.86	585.7	46.76	0.56	0.71	0.86	544.9	52.06	0.56	0.73	0.89
	24,000	674.5	38.23	0.58	0.72	0.89	638.3	42.31	0.56	0.75	0.90	600.6	46.98	0.58	0.76	0.92	560.6	52.29	0.59	0.81	0.95
71°F	16,000	664.7	38.07	0.39	0.51	0.62	630.1	42.19	0.40	0.52	0.63	594.0	46.89	0.39	0.53	0.63	554.3	52.21	0.36	0.51	0.65
	20,000	688.9	38.45	0.40	0.54	0.67	652.2	42.53	0.41	0.56	0.69	614.8	47.24	0.38	0.53	0.69	573.7	52.53	0.38	0.56	0.72
	24,000	706.6	38.74	0.42	0.58	0.72	669.1	42.83	0.39	0.56	0.75	629.8	47.49	0.39	0.57	0.74	587.1	52.74	0.40	0.59	0.77

HUMIDITROL® DEHUMIDIFICATION SYSTEM RATINGS

35 TON STANDARD EFFICIENCY LCH420S4M (MSAV®) WITH HUMIDITROL® OPERATING (2 COMPRESSORS - FULL LOAD)

Entering Wet Bulb Temperature	Total Air Volume	Outdoor Air Temperature Entering Outdoor Coil																				
		65°F						75°F					85°F					95°F				
		Total Cool Cap.	Comp. Motor Input	Sensible To Total Ratio (S/T)			Total Cool Cap.	Comp. Motor Input	Sensible To Total Ratio (S/T)			Total Cool Cap.	Comp. Motor Input	Sensible To Total Ratio (S/T)			Total Cool Cap.	Comp. Motor Input	Sensible To Total Ratio (S/T)			
				Dry Bulb					Dry Bulb					Dry Bulb					Dry Bulb			
cfm	kBtuh	kW	75°F	80°F	85°F	kBtuh	kW	75°F	80°F	85°F	kBtuh	kW	75°F	80°F	85°F	kBtuh	kW	75°F	80°F	85°F		
63°F	5600	134.1	10.11	0.49	0.69	0.89	106.0	11.01	0.34	0.61	0.88	78.0	11.92	0.20	0.54	0.87	50.0	12.83	0.06	0.46	0.86	
	7000	140.3	10.19	0.54	0.77	1.00	108.0	11.05	0.40	0.76	1.00	75.7	11.92	0.25	0.75	1.00	43.4	12.78	0.11	0.73	1.00	
	8400	146.5	10.28	0.60	0.86	1.00	110.0	11.10	0.45	0.90	1.00	73.4	11.92	0.30	0.95	1.00	36.8	12.73	0.16	1.00	1.00	
67°F	5600	157.1	10.41	0.32	0.50	0.68	128.2	11.33	0.23	0.43	0.63	99.3	12.24	0.14	0.36	0.59	70.4	13.16	0.05	0.29	0.54	
	7000	161.3	10.50	0.35	0.56	0.76	129.0	11.37	0.26	0.52	0.72	96.7	12.24	0.17	0.48	0.68	64.4	13.12	0.08	0.45	0.64	
	8400	165.5	10.58	0.37	0.61	0.79	129.8	11.41	0.29	0.61	0.75	94.1	12.24	0.20	0.61	0.71	58.4	13.07	0.12	0.60	0.67	
71°F	5600	180.1	10.72	0.16	0.32	0.47	150.3	11.64	0.12	0.25	0.38	120.6	12.56	0.08	0.19	0.30	90.9	13.49	0.03	0.12	0.21	
	7000	182.2	10.80	0.16	0.34	0.52	150.0	11.68	0.12	0.28	0.44	117.7	12.57	0.09	0.22	0.36	85.4	13.45	0.06	0.17	0.28	
	8400	184.4	10.89	0.15	0.36	0.58	149.6	11.73	0.13	0.31	0.50	114.8	12.57	0.10	0.26	0.42	79.9	13.41	0.08	0.21	0.34	

35 TON STANDARD EFFICIENCY LCH420S4M MSAV® WITH HUMIDITROL® OPERATING (4 COMPRESSORS - FULL LOAD)

Entering Wet Bulb Temperature	Total Air Volume	Outdoor Air Temperature Entering Outdoor Coil																				
		65°F						75°F					85°F					95°F				
		Total Cool Cap.	Comp. Motor Input	Sensible To Total Ratio (S/T)			Total Cool Cap.	Comp. Motor Input	Sensible To Total Ratio (S/T)			Total Cool Cap.	Comp. Motor Input	Sensible To Total Ratio (S/T)			Total Cool Cap.	Comp. Motor Input	Sensible To Total Ratio (S/T)			
				Dry Bulb					Dry Bulb					Dry Bulb					Dry Bulb			
cfm	kBtuh	kW	75°F	80°F	85°F	kBtuh	kW	75°F	80°F	85°F	kBtuh	kW	75°F	80°F	85°F	kBtuh	kW	75°F	80°F	85°F		
63°F	11,200	341.0	20.45	0.58	0.73	0.88	277.6	22.30	0.62	0.73	0.84	214.3	24.15	0.67	0.74	0.81	150.9	25.99	0.71	0.75	0.78	
	14,000	361.1	20.68	0.62	0.81	0.99	293.0	22.50	0.67	0.81	0.95	225.0	24.31	0.72	0.81	0.91	156.9	26.13	0.76	0.82	0.87	
	16,800	381.2	20.92	0.67	0.88	1.00	308.5	22.70	0.72	0.89	0.99	235.7	24.48	0.76	0.89	0.98	162.9	26.26	0.81	0.89	0.97	
67°F	11,200	379.5	21.01	0.42	0.57	0.71	323.7	22.97	0.41	0.54	0.68	267.8	24.93	0.40	0.52	0.65	212.0	26.89	0.38	0.50	0.61	
	14,000	397.8	21.20	0.45	0.62	0.79	336.7	23.13	0.44	0.60	0.76	275.6	25.05	0.43	0.58	0.74	214.6	26.97	0.42	0.57	0.71	
	16,800	416.0	21.40	0.48	0.68	0.83	349.7	23.28	0.48	0.66	0.82	283.5	25.17	0.47	0.65	0.81	217.2	27.06	0.47	0.63	0.80	
71°F	11,200	418.1	21.58	0.27	0.41	0.55	369.7	23.64	0.20	0.35	0.51	321.4	25.71	0.13	0.30	0.48	273.0	27.78	0.05	0.25	0.45	
	14,000	434.4	21.73	0.28	0.44	0.60	380.4	23.76	0.22	0.40	0.58	326.3	25.79	0.15	0.36	0.56	272.3	27.82	0.09	0.31	0.54	
	16,800	450.8	21.88	0.29	0.47	0.65	391.0	23.87	0.24	0.44	0.65	331.2	25.86	0.18	0.41	0.64	271.5	27.85	0.12	0.38	0.63	

35 TON HIGH EFFICIENCY LCH420H4M MSAV® WITH HUMIDITROL® OPERATING (2 COMPRESSORS - FULL LOAD)

Entering Wet Bulb Temperature	Total Air Volume	Outdoor Air Temperature Entering Outdoor Coil																				
		65°F						75°F					85°F					95°F				
		Total Cool Cap.	Comp. Motor Input	Sensible To Total Ratio (S/T)			Total Cool Cap.	Comp. Motor Input	Sensible To Total Ratio (S/T)			Total Cool Cap.	Comp. Motor Input	Sensible To Total Ratio (S/T)			Total Cool Cap.	Comp. Motor Input	Sensible To Total Ratio (S/T)			
				Dry Bulb					Dry Bulb					Dry Bulb					Dry Bulb			
cfm	kBtuh	kW	75°F	80°F	85°F	kBtuh	kW	75°F	80°F	85°F	kBtuh	kW	75°F	80°F	85°F	kBtuh	kW	75°F	80°F	85°F		
63°F	5600	125.3	9.88	0.51	0.71	0.91	95.4	10.86	0.37	0.63	0.89	65.5	11.85	0.23	0.55	0.87	35.6	12.84	0.09	0.47	0.85	
	7000	130.0	9.91	0.55	0.77	0.98	96.8	10.86	0.43	0.73	0.98	63.6	11.81	0.32	0.69	0.99	30.4	12.76	0.20	0.65	1.00	
	8400	134.7	9.94	0.60	0.82	1.00	98.2	10.85	0.50	0.82	1.00	61.8	11.76	0.40	0.82	1.00	25.3	12.67	0.30	0.83	1.00	
67°F	5600	145.5	10.07	0.35	0.53	0.71	116.3	11.09	0.25	0.45	0.65	87.1	12.11	0.16	0.37	0.59	57.9	13.13	0.06	0.30	0.53	
	7000	150.1	10.10	0.37	0.57	0.76	117.3	11.08	0.29	0.51	0.72	84.6	12.06	0.21	0.46	0.68	51.8	13.04	0.13	0.41	0.64	
	8400	154.7	10.13	0.40	0.61	0.80	118.4	11.07	0.33	0.58	0.75	82.0	12.01	0.27	0.55	0.71	45.6	12.94	0.21	0.52	0.67	
71°F	5600	165.7	10.27	0.18	0.34	0.50	137.2	11.32	0.13	0.27	0.40	108.7	12.37	0.08	0.19	0.31	80.2	13.42	0.03	0.12	0.21	
	7000	170.2	10.30	0.19	0.37	0.54	137.8	11.31	0.15	0.30	0.45	105.5	12.31	0.11	0.24	0.37	73.1	13.32	0.07	0.17	0.28	
	8400	174.7	10.32	0.20	0.40	0.59	138.5	11.29	0.17	0.34	0.51	102.2	12.25	0.14	0.28	0.42	66.0	13.22	0.11	0.22	0.34	

35 TON HIGH EFFICIENCY LCH420H4M MSAV® WITH HUMIDITROL® OPERATING (4 COMPRESSORS - FULL LOAD)

Entering Wet Bulb Temperature	Total Air Volume	Outdoor Air Temperature Entering Outdoor Coil																				
		65°F						75°F					85°F					95°F				
		Total Cool Cap.	Comp. Motor Input	Sensible To Total Ratio (S/T)			Total Cool Cap.	Comp. Motor Input	Sensible To Total Ratio (S/T)			Total Cool Cap.	Comp. Motor Input	Sensible To Total Ratio (S/T)			Total Cool Cap.	Comp. Motor Input	Sensible To Total Ratio (S/T)			
				Dry Bulb					Dry Bulb					Dry Bulb					Dry Bulb			
cfm	kBtuh	kW	75°F	80°F	85°F	kBtuh	kW	75°F	80°F	85°F	kBtuh	kW	75°F	80°F	85°F	kBtuh	kW	75°F	80°F	85°F		
63°F	11,200	323.1	19.66	0.62	0.77	0.92	258.7	21.52	0.64	0.80	0.94	194.3	23.39	0.67	0.83	0.97	129.9	25.25	0.69	0.86	1.00	
	14,000	338.1	19.79	0.68	0.83	0.99	271.0	21.65	0.71	0.85	0.98	203.9	23.50	0.74	0.86	0.98	136.7	25.36	0.78	0.88	0.98	
	16,800	353.2	19.92	0.73	0.90	1.00	283.3	21.77	0.78	0.90	0.97	213.4	23.62	0.82	0.90	0.95	143.5	25.46	0.87	0.90	0.92	
67°F	11,200	359.5	20.05	0.46	0.60	0.75	302.2	22.01	0.43	0.59	0.76	244.9	23.98	0.40	0.59	0.76	187.6	25.94	0.37	0.58	0.77	
	14,000	374.4	20.16	0.50	0.66	0.82	311.4	22.09	0.48	0.64	0.81	248.4	24.02	0.46	0.63	0.81	185.4	25.95	0.44	0.62	0.80	
	16,800	389.3	20.26	0.53	0.71	0.85	320.6	22.16	0.53	0.69	0.84	251.9	24.06	0.52	0.68	0.83	183.2	25.96	0.52	0.67	0.82	
71°F	11,200	395.8	20.43	0.29	0.44	0.58	345.7	22.50	0.21	0.39	0.57	295.5	24.56	0.13	0.34	0.55	245.3	26.63	0.05	0.29	0.53	
	14,000	410.6	20.52	0.31	0.48	0.64	351.8	22.53	0.25	0.44	0.64	292.9	24.54	0.18	0.41	0.63	234.1	26.54	0.11	0.37	0.63	
	16,800	425.4	20.61	0.33	0.52	0.70	357.9	22.56	0.28	0.49	0.71	290.4	24.51	0.22	0.47	0.72	222.8	26.46	0.17	0.44	0.72	

HUMIDITROL® DEHUMIDIFICATION SYSTEM RATINGS

40 TON STANDARD EFFICIENCY LCH480S4M MSAV® WITH HUMIDITROL® OPERATING (2 COMPRESSORS - FULL LOAD)

Entering Wet Bulb Temperature	Total Air Volume	Outdoor Air Temperature Entering Outdoor Coil																			
		65°F					75°F					85°F					95°F				
		Total Cool Cap.	Comp. Motor Input	Sensible To Total Ratio (S/T)			Total Cool Cap.	Comp. Motor Input	Sensible To Total Ratio (S/T)			Total Cool Cap.	Comp. Motor Input	Sensible To Total Ratio (S/T)			Total Cool Cap.	Comp. Motor Input	Sensible To Total Ratio (S/T)		
				Dry Bulb					Dry Bulb					Dry Bulb					Dry Bulb		
cfm	kBtuh	kW	75°F	80°F	85°F	kBtuh	kW	75°F	80°F	85°F	kBtuh	kW	75°F	80°F	85°F	kBtuh	kW	75°F	80°F	85°F	
63°F	6400	144.1	11.85	0.49	0.69	0.88	115.0	12.85	0.36	0.63	0.91	85.8	13.84	0.22	0.58	0.94	56.7	14.84	0.09	0.53	0.97
	8000	143.4	11.92	0.54	0.84	1.00	112.9	12.88	0.40	0.79	1.00	82.3	13.84	0.26	0.75	1.00	51.8	14.80	0.13	0.71	1.00
	9600	142.7	12.00	0.58	0.98	1.00	110.8	12.92	0.44	0.95	1.00	78.9	13.84	0.30	0.92	1.00	47.0	14.76	0.16	0.88	1.00
67°F	6400	163.7	12.21	0.31	0.50	0.68	135.1	13.23	0.23	0.44	0.65	106.5	14.25	0.15	0.38	0.61	77.9	15.27	0.07	0.33	0.58
	8000	154.7	12.27	0.33	0.63	0.87	136.1	13.93	0.25	0.56	0.79	117.4	15.60	0.17	0.50	0.71	98.7	17.27	0.09	0.43	0.63
	9600	145.8	12.33	0.34	0.77	1.00	137.0	14.64	0.26	0.69	0.89	128.3	16.95	0.19	0.61	0.78	119.5	19.26	0.11	0.54	0.67
71°F	6400	183.3	12.57	0.13	0.30	0.48	155.2	13.61	0.10	0.24	0.38	127.1	14.65	0.08	0.18	0.29	99.1	15.70	0.05	0.12	0.19
	8000	166.1	12.61	0.12	0.43	0.74	159.2	14.99	0.09	0.34	0.58	152.4	17.36	0.07	0.25	0.42	145.6	19.73	0.05	0.16	0.26
	9600	148.8	12.66	0.10	0.55	1.00	163.2	16.36	0.09	0.43	0.78	177.7	20.07	0.07	0.31	0.56	192.1	23.77	0.05	0.19	0.33

40 TON STANDARD EFFICIENCY LCH480S4M MSAV® WITH HUMIDITROL® OPERATING (4 COMPRESSORS - FULL LOAD)

Entering Wet Bulb Temperature	Total Air Volume	Outdoor Air Temperature Entering Outdoor Coil																			
		85°F					95°F					105°F					115°F				
		Total Cool Cap.	Comp. Motor Input	Sensible To Total Ratio (S/T)			Total Cool Cap.	Comp. Motor Input	Sensible To Total Ratio (S/T)			Total Cool Cap.	Comp. Motor Input	Sensible To Total Ratio (S/T)			Total Cool Cap.	Comp. Motor Input	Sensible To Total Ratio (S/T)		
				Dry Bulb					Dry Bulb					Dry Bulb					Dry Bulb		
cfm	kBtuh	kW	75°F	80°F	85°F	kBtuh	kW	75°F	80°F	85°F	kBtuh	kW	75°F	80°F	85°F	kBtuh	kW	75°F	80°F	85°F	
63°F	12,800	363.3	23.70	0.60	0.79	0.98	291.2	25.72	0.67	0.86	0.99	219.2	27.75	0.74	0.93	0.99	147.1	29.77	0.81	1.00	1.00
	16,000	347.2	23.93	0.78	0.89	1.00	285.2	25.93	0.81	0.93	1.00	223.1	27.93	0.84	0.96	1.00	161.1	29.92	0.87	1.00	1.00
	19,200	331.2	24.17	0.96	1.00	1.00	279.1	26.14	0.95	1.00	1.00	227.1	28.11	0.94	1.00	1.00	175.0	30.08	0.93	1.00	1.00
67°F	12,800	406.0	24.33	0.43	0.60	0.77	344.6	26.53	0.43	0.61	0.76	283.3	28.74	0.43	0.62	0.75	222.0	30.94	0.43	0.64	0.74
	16,000	410.4	24.51	0.53	0.67	0.80	350.6	26.68	0.51	0.67	0.80	290.8	28.85	0.50	0.67	0.79	230.9	31.03	0.49	0.67	0.78
	19,200	414.8	24.69	0.62	0.74	0.83	356.5	26.83	0.60	0.72	0.83	298.2	28.97	0.57	0.71	0.82	239.9	31.11	0.55	0.70	0.82
71°F	12,800	448.6	24.96	0.26	0.41	0.56	398.1	27.34	0.20	0.36	0.53	347.5	29.73	0.13	0.32	0.51	296.9	32.11	0.06	0.27	0.48
	16,000	473.6	25.09	0.28	0.44	0.61	416.0	27.44	0.22	0.41	0.59	358.4	29.78	0.17	0.37	0.57	300.8	32.13	0.12	0.34	0.56
	19,200	498.5	25.21	0.29	0.47	0.66	433.9	27.53	0.25	0.45	0.65	369.3	29.84	0.21	0.43	0.64	304.7	32.15	0.17	0.40	0.63

40 TON HIGH EFFICIENCY LCH480H4M MSAV® WITH HUMIDITROL® OPERATING (2 COMPRESSORS - FULL LOAD)

Entering Wet Bulb Temperature	Total Air Volume	Outdoor Air Temperature Entering Outdoor Coil																			
		65°F					75°F					85°F					95°F				
		Total Cool Cap.	Comp. Motor Input	Sensible To Total Ratio (S/T)			Total Cool Cap.	Comp. Motor Input	Sensible To Total Ratio (S/T)			Total Cool Cap.	Comp. Motor Input	Sensible To Total Ratio (S/T)			Total Cool Cap.	Comp. Motor Input	Sensible To Total Ratio (S/T)		
				Dry Bulb					Dry Bulb					Dry Bulb					Dry Bulb		
cfm	kBtuh	kW	75°F	80°F	85°F	kBtuh	kW	75°F	80°F	85°F	kBtuh	kW	75°F	80°F	85°F	kBtuh	kW	75°F	80°F	85°F	
63°F	6400	150.0	11.61	0.51	0.73	0.95	114.7	12.62	0.40	0.67	0.93	79.5	13.64	0.29	0.61	0.92	44.3	14.65	0.18	0.55	0.91
	8000	145.0	11.72	0.63	0.84	1.00	112.0	12.69	0.48	0.81	1.00	79.1	13.66	0.32	0.77	1.00	46.2	14.64	0.17	0.74	1.00
	9600	139.9	11.82	0.75	0.96	1.00	109.4	12.76	0.55	0.95	1.00	78.8	13.69	0.36	0.94	1.00	48.2	14.62	0.16	0.93	1.00
67°F	6400	177.8	12.01	0.34	0.53	0.72	135.4	13.03	0.36	0.51	0.67	93.0	14.04	0.37	0.49	0.62	50.6	15.05	0.38	0.48	0.57
	8000	178.1	12.12	0.40	0.60	0.77	138.4	13.10	0.35	0.58	0.73	98.8	14.08	0.30	0.55	0.69	59.2	15.05	0.26	0.53	0.65
	9600	178.4	12.23	0.46	0.67	0.80	141.5	13.18	0.35	0.64	0.77	104.6	14.12	0.24	0.62	0.73	67.7	15.06	0.13	0.59	0.69
71°F	6400	205.7	12.41	0.17	0.33	0.49	156.1	13.43	0.31	0.36	0.40	106.5	14.44	0.45	0.38	0.31	56.8	15.45	0.59	0.41	0.23
	8000	211.2	12.53	0.17	0.36	0.55	164.9	13.51	0.23	0.35	0.47	118.5	14.49	0.29	0.34	0.39	72.1	15.47	0.34	0.32	0.30
	9600	216.8	12.65	0.17	0.39	0.61	173.6	13.60	0.15	0.34	0.53	130.5	14.55	0.12	0.29	0.46	87.3	15.50	0.10	0.24	0.38

40 TON HIGH EFFICIENCY LCH480H4M MSAV® WITH HUMIDITROL® OPERATING (4 COMPRESSORS - FULL LOAD)

Entering Wet Bulb Temperature	Total Air Volume	Outdoor Air Temperature Entering Outdoor Coil																			
		85°F					95°F					105°F					115°F				
		Total Cool Cap.	Comp. Motor Input	Sensible To Total Ratio (S/T)			Total Cool Cap.	Comp. Motor Input	Sensible To Total Ratio (S/T)			Total Cool Cap.	Comp. Motor Input	Sensible To Total Ratio (S/T)			Total Cool Cap.	Comp. Motor Input	Sensible To Total Ratio (S/T)		
				Dry Bulb					Dry Bulb					Dry Bulb					Dry Bulb		
cfm	kBtuh	kW	75°F	80°F	85°F	kBtuh	kW	75°F	80°F	85°F	kBtuh	kW	75°F	80°F	85°F	kBtuh	kW	75°F	80°F	85°F	
63°F	12,800	364.0	23.30	0.60	0.77	0.94	318.9	25.63	0.56	0.76	0.96	273.8	27.96	0.51	0.75	0.98	228.6	30.29	0.47	0.74	1.00
	16,000	401.4	23.60	0.64	0.81	0.99	345.9	25.85	0.62	0.82	0.99	290.4	28.09	0.60	0.82	1.00	235.0	30.33	0.59	0.83	1.00
	19,200	438.7	23.90	0.67	0.86	1.00	372.9	26.06	0.68	0.88	1.00	307.1	28.22	0.70	0.89	1.00	241.3	30.37	0.71	0.91	1.00
67°F	12,800	413.6	24.04	0.44	0.59	0.75	366.2	26.37	0.38	0.56	0.74	318.8	28.70	0.32	0.53	0.74	271.3	31.03	0.26	0.50	0.73
	16,000	446.2	24.34	0.46	0.63	0.80	392.7	26.58	0.42	0.61	0.79	339.2	28.81	0.38	0.59	0.78	285.7	31.05	0.34	0.57	0.77
	19,200	478.9	24.65	0.48	0.66	0.82	419.3	26.79	0.46	0.66	0.82	359.7	28.92	0.44	0.65	0.81	300.1	31.06	0.42	0.65	0.81
71°F	12,800	463.2	24.77	0.27	0.42	0.56	413.5	27.11	0.20	0.36	0.53	363.8	29.44	0.13	0.31	0.49	314.0	31.77	0.06	0.26	0.45
	16,000	491.1	25.08	0.28	0.44	0.60	439.6	27.31	0.22	0.40	0.58	388.0	29.53	0.16	0.36	0.56	336.5	31.76	0.10	0.32	0.54
	19,200	519.1	25.39	0.29	0.47	0.65	465.7	27.51	0.24	0.44	0.64	412.3	29.63	0.19	0.41	0.63	358.9	31.75	0.14	0.38	0.62

HUMIDITROL® DEHUMIDIFICATION SYSTEM RATINGS

45 TON STANDARD EFFICIENCY LCH540S4M MSAV® WITH HUMIDITROL® OPERATING (2 COMPRESSORS - FULL LOAD)

Entering Wet Bulb Temperature	Total Air Volume	Outdoor Air Temperature Entering Outdoor Coil																			
		65°F					75°F					85°F					95°F				
		Total Cool Cap.	Comp. Motor Input	Sensible To Total Ratio (S/T)			Total Cool Cap.	Comp. Motor Input	Sensible To Total Ratio (S/T)			Total Cool Cap.	Comp. Motor Input	Sensible To Total Ratio (S/T)			Total Cool Cap.	Comp. Motor Input	Sensible To Total Ratio (S/T)		
				Dry Bulb					Dry Bulb					Dry Bulb					Dry Bulb		
cfm	kBtuh	kW	75°F	80°F	85°F	kBtuh	kW	75°F	80°F	85°F	kBtuh	kW	75°F	80°F	85°F	kBtuh	kW	75°F	80°F	85°F	
63°F	7200	170.5	13.70	0.49	0.70	0.92	133.8	14.90	0.37	0.64	0.92	97.0	16.10	0.25	0.58	0.92	60.3	17.20	0.13	0.52	0.92
	9000	171.9	13.90	0.57	0.80	0.99	133.1	15.00	0.43	0.77	1.00	94.3	16.10	0.30	0.75	1.00	55.4	17.20	0.16	0.73	1.00
	10,800	173.3	14.00	0.65	0.89	1.00	132.4	15.00	0.50	0.90	1.00	91.5	16.10	0.35	0.92	1.00	50.6	17.20	0.20	0.93	1.00
67°F	7200	202.6	14.20	0.32	0.51	0.69	160.9	15.40	0.29	0.47	0.65	119.2	16.50	0.25	0.43	0.61	77.5	17.70	0.22	0.39	0.56
	9000	205.5	14.30	0.36	0.57	0.76	162.2	15.50	0.30	0.54	0.72	118.9	16.60	0.25	0.51	0.68	75.6	17.70	0.19	0.49	0.64
	10,800	208.4	14.50	0.40	0.63	0.79	163.5	15.50	0.32	0.61	0.75	118.6	16.60	0.24	0.60	0.71	73.7	17.70	0.15	0.58	0.68
71°F	7200	234.7	14.70	0.16	0.31	0.47	188.0	15.90	0.21	0.29	0.38	141.4	17.00	0.26	0.28	0.29	94.8	18.20	0.31	0.26	0.21
	9000	239.1	14.80	0.16	0.34	0.52	191.3	15.90	0.17	0.31	0.44	143.6	17.10	0.19	0.28	0.36	95.8	18.20	0.21	0.25	0.28
	10,800	243.5	14.90	0.15	0.36	0.57	194.7	16.00	0.14	0.32	0.50	145.8	17.10	0.13	0.27	0.42	96.9	18.20	0.11	0.23	0.35

45 TON STANDARD EFFICIENCY LCH540S4M MSAV® WITH HUMIDITROL® OPERATING (4 COMPRESSORS - FULL LOAD)

Entering Wet Bulb Temperature	Total Air Volume	Outdoor Air Temperature Entering Outdoor Coil																			
		85°F					95°F					105°F					115°F				
		Total Cool Cap.	Comp. Motor Input	Sensible To Total Ratio (S/T)			Total Cool Cap.	Comp. Motor Input	Sensible To Total Ratio (S/T)			Total Cool Cap.	Comp. Motor Input	Sensible To Total Ratio (S/T)			Total Cool Cap.	Comp. Motor Input	Sensible To Total Ratio (S/T)		
				Dry Bulb					Dry Bulb					Dry Bulb					Dry Bulb		
cfm	kBtuh	kW	75°F	80°F	85°F	kBtuh	kW	75°F	80°F	85°F	kBtuh	kW	75°F	80°F	85°F	kBtuh	kW	75°F	80°F	85°F	
63°F	14,400	425.2	27.60	0.59	0.76	0.93	366.8	30.30	0.56	0.76	0.95	308.5	32.90	0.53	0.76	0.98	250.1	35.60	0.49	0.75	1.00
	18,000	460.2	28.00	0.64	0.81	0.98	394.5	30.50	0.62	0.81	0.98	328.8	33.00	0.61	0.81	0.99	263.1	35.50	0.60	0.81	1.00
	21,600	495.1	28.30	0.68	0.85	1.00	422.1	30.70	0.69	0.86	1.00	349.1	33.10	0.69	0.87	0.99	276.1	35.50	0.70	0.88	0.99
67°F	14,400	476.4	28.40	0.43	0.59	0.74	417.1	31.10	0.38	0.56	0.74	357.8	33.90	0.33	0.54	0.74	298.5	36.60	0.28	0.51	0.73
	18,000	513.0	28.80	0.46	0.62	0.79	448.1	31.40	0.42	0.61	0.79	383.3	33.90	0.39	0.59	0.78	318.4	36.50	0.36	0.58	0.78
	21,600	549.5	29.20	0.48	0.66	0.82	479.1	31.60	0.46	0.65	0.82	408.7	34.00	0.45	0.65	0.82	338.3	36.40	0.43	0.64	0.82
71°F	14,400	527.6	29.30	0.27	0.41	0.55	467.4	32.00	0.20	0.36	0.52	407.2	34.80	0.14	0.32	0.50	346.9	37.50	0.07	0.27	0.47
	18,000	565.7	29.70	0.28	0.44	0.60	501.7	32.30	0.22	0.41	0.59	437.7	34.90	0.17	0.37	0.57	373.7	37.50	0.11	0.34	0.56
	21,600	603.8	30.10	0.28	0.47	0.65	536.1	32.50	0.24	0.45	0.65	468.3	35.00	0.20	0.42	0.65	400.5	37.40	0.16	0.40	0.65

50 TON STANDARD EFFICIENCY LCH600H4M MSAV® WITH HUMIDITROL® OPERATING (2 COMPRESSORS - FULL LOAD)

Entering Wet Bulb Temperature	Total Air Volume	Outdoor Air Temperature Entering Outdoor Coil																			
		65°F					75°F					85°F					95°F				
		Total Cool Cap.	Comp. Motor Input	Sensible To Total Ratio (S/T)			Total Cool Cap.	Comp. Motor Input	Sensible To Total Ratio (S/T)			Total Cool Cap.	Comp. Motor Input	Sensible To Total Ratio (S/T)			Total Cool Cap.	Comp. Motor Input	Sensible To Total Ratio (S/T)		
				Dry Bulb					Dry Bulb					Dry Bulb					Dry Bulb		
cfm	kBtuh	kW	75°F	80°F	85°F	kBtuh	kW	75°F	80°F	85°F	kBtuh	kW	75°F	80°F	85°F	kBtuh	kW	75°F	80°F	85°F	
63°F	8000	191.1	15.86	0.46	0.68	0.90	152.8	17.17	0.33	0.62	0.91	114.5	18.48	0.20	0.56	0.92	76.2	19.79	0.07	0.50	0.93
	10,000	198.8	16.01	0.51	0.75	0.99	154.1	17.25	0.39	0.74	0.99	109.4	18.50	0.27	0.73	1.00	64.6	19.74	0.15	0.72	1.00
	12,000	206.6	16.15	0.56	0.82	1.00	155.4	17.33	0.45	0.86	1.00	104.2	18.51	0.34	0.90	1.00	53.0	19.69	0.23	0.94	1.00
67°F	8000	227.3	16.42	0.30	0.49	0.67	186.4	17.74	0.22	0.43	0.63	145.4	19.06	0.14	0.37	0.60	104.5	20.38	0.06	0.31	0.56
	10,000	232.9	16.56	0.32	0.53	0.74	186.0	17.81	0.26	0.50	0.70	139.0	19.07	0.19	0.47	0.66	92.1	20.33	0.12	0.44	0.63
	12,000	238.5	16.70	0.35	0.58	0.77	185.5	17.89	0.29	0.58	0.73	132.6	19.08	0.23	0.58	0.70	79.7	20.28	0.18	0.58	0.66
71°F	8000	263.6	16.97	0.14	0.30	0.45	220.0	18.30	0.11	0.23	0.36	176.3	19.63	0.08	0.17	0.27	132.7	20.96	0.04	0.11	0.18
	10,000	267.0	17.11	0.14	0.32	0.49	217.8	18.37	0.12	0.27	0.41	168.7	19.64	0.10	0.22	0.33	119.6	20.91	0.08	0.17	0.25
	12,000	270.3	17.24	0.13	0.34	0.54	215.7	18.45	0.13	0.30	0.47	161.1	19.66	0.13	0.26	0.39	106.4	20.86	0.13	0.22	0.32

50 TON STANDARD EFFICIENCY LCH600H4M MSAV® WITH HUMIDITROL® OPERATING (4 COMPRESSORS - FULL LOAD)

Entering Wet Bulb Temperature	Total Air Volume	Outdoor Air Temperature Entering Outdoor Coil																			
		85°F					95°F					105°F					115°F				
		Total Cool Cap.	Comp. Motor Input	Sensible To Total Ratio (S/T)			Total Cool Cap.	Comp. Motor Input	Sensible To Total Ratio (S/T)			Total Cool Cap.	Comp. Motor Input	Sensible To Total Ratio (S/T)			Total Cool Cap.	Comp. Motor Input	Sensible To Total Ratio (S/T)		
				Dry Bulb					Dry Bulb					Dry Bulb					Dry Bulb		
cfm	kBtuh	kW	75°F	80°F	85°F	kBtuh	kW	75°F	80°F	85°F	kBtuh	kW	75°F	80°F	85°F	kBtuh	kW	75°F	80°F	85°F	
63°F	16,000	486.4	31.84	0.58	0.75	0.91	414.8	34.88	0.56	0.75	0.94	343.2	37.93	0.54	0.76	0.97	271.6	40.97	0.52	0.77	1.00
	20,000	519.0	32.30	0.63	0.80	0.96	443.1	35.12	0.62	0.80	0.97	367.1	37.94	0.62	0.80	0.98	291.2	40.75	0.61	0.80	0.99
	24,000	551.6	32.77	0.68	0.85	1.00	471.3	35.36	0.69	0.85	0.99	391.1	37.95	0.69	0.84	0.99	310.8	40.54	0.70	0.84	0.98
67°F	16,000	539.3	32.81	0.43	0.58	0.73	468.1	35.92	0.38	0.56	0.73	396.9	39.03	0.34	0.54	0.74	325.7	42.13	0.30	0.52	0.74
	20,000	579.7	33.29	0.45	0.62	0.78	503.5	36.18	0.42	0.60	0.78	427.3	39.07	0.40	0.59	0.79	351.1	41.96	0.37	0.58	0.79
	24,000	620.1	33.77	0.48	0.66	0.82	538.9	36.44	0.46	0.65	0.83	457.7	39.12	0.45	0.64	0.83	376.5	41.79	0.44	0.63	0.83
71°F	16,000	592.1	33.79	0.27	0.41	0.55	521.3	36.96	0.21	0.37	0.52	450.5	40.13	0.15	0.32	0.50	379.8	43.29	0.08	0.28	0.48
	20,000	640.3	34.28	0.27	0.44	0.60	563.9	37.24	0.23	0.41	0.59	487.4	40.21	0.18	0.38	0.59	411.0	43.17	0.13	0.35	0.58
	24,000	688.6	34.77	0.28	0.46	0.65	606.5	37.53	0.24	0.45	0.66	524.3	40.29	0.21	0.44	0.67	442.2	43.04	0.18	0.43	0.68

BLOWER DATA

BLOWER TABLE INCLUDES RESISTANCE FOR BASE UNIT ONLY WITH DRY INDOOR COIL AND AIR FILTERS IN PLACE

Add factory installed options air resistance, then determine from blower table blower motor output and drive kit required.

See page 59 for horizontal configured unit air resistance.

See page 60 for factory installed options air resistance data.

See page 61 for factory installed drive kit specifications.

TOTAL STATIC PRESSURE - 0.2 Thru 2.4 in. w.g. For 2.6 thru 4.6 in. w.g., see next page

Air Volume cfm	0.2		0.4		0.6		0.8		1.0		1.2		1.4		1.6		1.8		2.0		2.2		2.4	
	RPM	BHP	RPM	BHP	RPM	BHP	RPM	BHP	RPM	BHP	RPM	BHP	RPM	BHP	RPM	BHP	RPM	BHP	RPM	BHP	RPM	BHP	RPM	BHP
8000	---	---	---	---	562	0.90	593	1.76	625	2.59	658	3.37	692	4.11	728	4.81	765	5.48	802	6.14	838	6.80	873	7.46
8500	---	---	539	0.45	569	1.31	600	2.16	632	2.97	664	3.75	699	4.48	735	5.17	772	5.84	808	6.51	844	7.17	879	7.83
9000	---	---	547	0.87	576	1.73	607	2.57	639	3.38	672	4.14	706	4.87	743	5.56	779	6.23	815	6.90	851	7.56	885	8.22
9500	526	0.47	555	1.32	584	2.16	615	3.00	647	3.80	680	4.56	715	5.29	751	5.97	787	6.65	823	7.32	858	7.99	892	8.65
10,000	535	0.94	563	1.78	593	2.62	624	3.45	655	4.25	689	5.01	724	5.72	760	6.41	796	7.09	831	7.76	865	8.44	899	9.11
10,500	544	1.42	572	2.26	602	3.09	633	3.92	665	4.71	698	5.47	733	6.19	769	6.88	805	7.56	840	8.24	874	8.93	906	9.60
11,000	553	1.92	582	2.75	612	3.59	642	4.41	675	5.21	708	5.96	744	6.68	779	7.37	815	8.06	849	8.75	882	9.44	914	10.12
11,500	564	2.44	592	3.27	622	4.11	653	4.93	685	5.72	719	6.48	754	7.20	790	7.89	825	8.59	859	9.29	891	9.99	922	10.67
12,000	574	2.98	603	3.81	633	4.65	664	5.47	697	6.27	731	7.02	766	7.74	801	8.45	835	9.16	869	9.87	900	10.57	930	11.25
12,500	585	3.55	614	4.38	644	5.22	676	6.04	708	6.84	743	7.59	778	8.32	813	9.03	846	9.75	879	10.48	910	11.18	939	11.86
13,000	597	4.13	626	4.97	656	5.81	688	6.64	721	7.44	756	8.20	790	8.93	825	9.66	858	10.39	889	11.12	919	11.83	948	12.51
13,500	609	4.73	638	5.58	669	6.44	701	7.28	734	8.07	769	8.84	803	9.58	837	10.32	869	11.06	900	11.80	929	12.51	957	13.19
14,000	622	5.34	651	6.21	682	7.09	715	7.95	748	8.76	783	9.53	817	10.28	850	11.02	881	11.77	911	12.51	939	13.22	966	13.91
14,500	635	5.98	665	6.88	696	7.79	729	8.67	763	9.49	797	10.27	830	11.02	863	11.77	893	12.52	922	13.26	950	13.97	976	14.66
15,000	648	6.67	679	7.61	711	8.55	745	9.44	778	10.27	812	11.05	845	11.81	876	12.55	905	13.30	933	14.04	960	14.75	986	15.45
15,500	663	7.42	694	8.40	727	9.35	760	10.25	794	11.09	827	11.87	859	12.62	889	13.36	918	14.11	945	14.85	971	15.56	996	16.28
16,000	679	8.23	710	9.24	743	10.21	777	11.12	810	11.95	842	12.72	873	13.46	902	14.20	930	14.95	956	15.68	981	16.41	1006	17.15
16,500	695	9.11	727	10.14	760	11.11	793	12.01	826	12.83	857	13.60	887	14.33	915	15.06	942	15.81	967	16.56	992	17.30	1016	18.06
17,000	712	10.04	745	11.08	778	12.05	810	12.94	842	13.74	872	14.49	901	15.22	928	15.95	954	16.70	979	17.46	1003	18.23	1027	19.02
17,500	730	11.02	763	12.06	795	13.02	827	13.88	858	14.68	888	15.41	915	16.13	941	16.87	967	17.63	991	18.41	1015	19.21	1038	20.03
18,000	748	12.04	781	13.07	813	14.00	844	14.85	874	15.63	903	16.36	929	17.07	955	17.81	979	18.59	1003	19.41	1026	20.24	1049	21.10
18,500	767	13.10	799	14.10	831	15.02	861	15.85	890	16.61	917	17.33	943	18.05	968	18.81	992	19.62	1015	20.46	1038	21.34	1060	22.23
19,000	786	14.20	818	15.17	849	16.06	878	16.87	906	17.62	932	18.34	957	19.08	981	19.86	1005	20.70	1028	21.59	1050	22.50	1072	23.42
19,500	806	15.32	837	16.26	866	17.13	895	17.92	922	18.66	947	19.40	971	20.17	995	20.99	1018	21.86	1040	22.78	1063	23.72	1084	24.67
20,000	825	16.48	855	17.39	884	18.23	911	19.01	937	19.75	962	20.51	985	21.32	1008	22.17	1031	23.09	1053	24.04	1075	25.01	1097	25.98
20,500	845	17.67	874	18.55	902	19.37	928	20.13	953	20.89	976	21.68	1000	22.53	1022	23.43	1045	24.38	1067	25.37	1088	26.37	1110	27.35
21,000	864	18.89	892	19.74	919	20.53	944	21.30	968	22.09	991	22.92	1014	23.80	1036	24.75	1059	25.75	1080	26.77	1102	27.79	1123	28.78
21,500	883	20.13	910	20.95	936	21.73	960	22.52	984	23.34	1006	24.22	1029	25.15	1051	26.15	1073	27.19	1094	28.24	1116	29.27	1137	30.26
22,000	902	21.38	928	22.18	953	22.98	976	23.80	999	24.66	1021	25.59	1044	26.59	1066	27.64	1087	28.71	1109	29.77	1130	30.80	1151	31.79
22,500	921	22.65	945	23.46	969	24.28	992	25.14	1015	26.06	1037	27.05	1059	28.11	1081	29.20	1102	30.29	1123	31.36	1144	32.39	1165	33.37

NOTE - Minimum CFM requirements for units with electric heat:

LCH420 - 9800 cfm, LCH480 - 11,200 cfm, LCH540 - 12,600 cfm, LCH600 - 14,000 cfm.

BLOWER DATA

BLOWER TABLE INCLUDES RESISTANCE FOR BASE UNIT ONLY WITH DRY INDOOR COIL AND AIR FILTERS IN PLACE

Add factory installed options air resistance, then determine from blower table blower motor output and drive kit required.

See page 59 for horizontal configured unit air resistance.

See page 60 for factory installed options air resistance data.

See page 61 for factory installed drive kit specifications.

TOTAL STATIC PRESSURE - 2.6 Thru 4.6 in. w.g. For .2 thru 2.4 in. w.g., see previous page

Air Volume cfm	2.6		2.8		3.0		3.2		3.4		3.6		3.8		4.0		4.2		4.4		4.6	
	RPM	BHP	RPM	BHP	RPM	BHP	RPM	BHP	RPM	BHP	RPM	BHP	RPM	BHP	RPM	BHP	RPM	BHP	RPM	BHP	RPM	BHP
8000	908	8.1	940	8.72	970	9.33	1000	9.95	1029	10.59	1057	11.25	1084	11.91	1110	12.60	1136	13.31	1161	14.01	1188	14.71
8500	913	8.47	944	9.10	975	9.73	1004	10.36	1032	11.00	1059	11.66	1086	12.35	1113	13.06	1139	13.79	1165	14.54	1191	15.30
9000	918	8.87	949	9.51	979	10.15	1007	10.78	1035	11.43	1062	12.10	1089	12.81	1115	13.54	1141	14.28	1168	15.04	1194	15.83
9500	924	9.30	954	9.95	983	10.59	1011	11.24	1038	11.89	1065	12.58	1092	13.30	1118	14.03	1144	14.79	1170	15.56	1197	16.36
10,000	930	9.76	960	10.42	988	11.07	1015	11.72	1042	12.39	1068	13.08	1095	13.81	1121	14.55	1147	15.31	1173	16.09	1199	16.90
10,500	937	10.26	966	10.91	994	11.57	1020	12.24	1046	12.92	1072	13.62	1098	14.35	1124	15.10	1150	15.86	1176	16.65	1202	17.45
11,000	944	10.78	972	11.44	999	12.11	1025	12.79	1051	13.48	1076	14.19	1102	14.93	1128	15.68	1153	16.44	1178	17.22	1204	18.02
11,500	951	11.33	979	12.00	1005	12.68	1031	13.37	1056	14.08	1081	14.80	1106	15.54	1131	16.29	1156	17.05	1181	17.82	1207	18.61
12,000	959	11.92	986	12.6	1012	13.29	1037	13.99	1062	14.71	1086	15.44	1111	16.18	1135	16.93	1160	17.69	1185	18.46	1210	19.25
12,500	967	12.54	993	13.23	1018	13.93	1043	14.65	1068	15.38	1092	16.12	1116	16.87	1140	17.62	1164	18.37	1189	19.14	1214	19.92
13,000	975	13.19	1001	13.89	1026	14.61	1050	15.34	1074	16.09	1098	16.84	1121	17.59	1145	18.34	1169	19.09	1193	19.85	1218	20.64
13,500	983	13.88	1008	14.59	1033	15.33	1057	16.08	1081	16.84	1104	17.60	1127	18.36	1151	19.11	1174	19.85	1198	20.61	1223	21.40
14,000	992	14.61	1017	15.33	1041	16.09	1064	16.86	1088	17.63	1111	18.40	1134	19.16	1157	19.91	1180	20.66	1204	21.42	1229	22.21
14,500	1001	15.37	1025	16.12	1049	16.89	1072	17.68	1095	18.47	1118	19.24	1141	20.00	1163	20.75	1187	21.50	1210	22.26	1235	23.05
15,000	1010	16.18	1034	16.94	1057	17.73	1080	18.54	1103	19.34	1125	20.12	1148	20.88	1170	21.63	1193	22.38	1217	23.14	1242	23.94
15,500	1020	17.03	1043	17.81	1066	18.62	1089	19.44	1111	20.25	1133	21.04	1156	21.80	1178	22.55	1201	23.29	1224	24.06	1249	24.88
16,000	1029	17.92	1052	18.73	1075	19.56	1097	20.39	1120	21.20	1142	21.99	1164	22.75	1186	23.50	1209	24.25	1232	25.03	1258	25.86
16,500	1039	18.86	1062	19.69	1084	20.54	1107	21.37	1128	22.19	1150	22.98	1172	23.74	1194	24.49	1217	25.25	1241	26.05	1266	26.89
17,000	1050	19.85	1072	20.70	1094	21.56	1116	22.40	1138	23.22	1159	24.01	1181	24.77	1203	25.53	1226	26.30	1250	27.11	1275	27.97
17,500	1060	20.89	1082	21.76	1104	22.62	1126	23.47	1147	24.29	1169	25.07	1190	25.84	1213	26.61	1236	27.40	1260	28.22	1285	29.10
18,000	1071	21.99	1093	22.87	1115	23.74	1136	24.58	1157	25.40	1179	26.19	1200	26.96	1223	27.74	1246	28.54	1270	29.38	1296	30.27
18,500	1082	23.14	1104	24.03	1125	24.90	1147	25.75	1168	26.56	1189	27.35	1211	28.13	1233	28.92	1256	29.73	1281	30.58	1306	31.48
19,000	1094	24.34	1115	25.25	1136	26.12	1158	26.96	1179	27.78	1200	28.57	1222	29.35	1244	30.14	1267	30.96	1292	31.81	1317	32.71
19,500	1106	25.61	1127	26.52	1148	27.39	1169	28.23	1190	29.04	1211	29.83	1233	30.61	1255	31.40	1279	32.21	1303	33.06	1329	33.95
20,000	1118	26.93	1139	27.84	1160	28.71	1181	29.55	1202	30.35	1223	31.13	1245	31.91	1267	32.69	1290	33.50	1315	34.34	---	---
20,500	1131	28.30	1152	29.21	1172	30.08	1193	30.90	1214	31.70	1235	32.47	1257	33.23	1279	34.01	---	---	---	---	---	---
21,000	1144	29.73	1165	30.63	1185	31.48	1206	32.30	1226	33.08	1247	33.84	---	---	---	---	---	---	---	---	---	---
21,500	1157	31.20	1178	32.09	1198	32.93	1218	33.73	1239	34.49	---	---	---	---	---	---	---	---	---	---	---	---
22,000	1171	32.72	1191	33.59	1211	34.41	---	---	---	---	---	---	---	---	---	---	---	---	---	---	---	---
22,500	1185	34.28	---	---	---	---	---	---	---	---	---	---	---	---	---	---	---	---	---	---	---	---

NOTE - Minimum CFM requirements for units with electric heat:

LCH420 - 9800 cfm, LCH480 - 11,200 cfm, LCH540 - 12,600 cfm, LCH600 - 14,000 cfm.

BLOWER DATA

POWER EXHAUST BLOWERS

¹ 50% HIGH STATIC OPERATION, NO ERW

Air Volume cfm	Return Duct Negative Static Pressure - Inches Water Gauge (Pa)																					
	0		0.1		0.2		0.3		0.4		0.5		0.6		0.7		0.8		0.9		1.0	
	RPM	BHP	RPM	BHP	RPM	BHP	RPM	BHP	RPM	BHP	RPM	BHP	RPM	BHP	RPM	BHP	RPM	BHP	RPM	BHP	RPM	BHP
4000	410	0.75	465	1.00	520	1.25	575	1.50	630	1.80	685	2.15	740	2.50	795	2.85	845	3.25	900	3.70	955	4.15
4500	460	1.10	510	1.35	560	1.60	610	1.90	655	2.20	705	2.55	755	2.90	805	3.30	850	3.70	900	4.15	945	4.55
5000	510	1.50	555	1.75	600	2.05	645	2.40	690	2.70	735	3.10	775	3.40	820	3.85	865	4.25	910	4.70	950	5.15
5500	560	2.00	600	2.25	645	2.60	685	2.95	725	3.30	765	3.70	805	4.05	845	4.50	885	4.90	925	5.35	965	5.85
6000	610	2.55	650	2.90	685	3.25	725	3.60	760	3.95	800	4.40	835	4.80	870	5.20	910	5.65	945	6.10	980	6.55
6500	665	3.30	700	3.65	730	3.95	765	4.35	800	4.75	835	5.20	870	5.60	905	6.10	935	6.50	970	7.00	1005	7.50
7000	715	4.10	745	4.45	780	4.90	810	5.25	840	5.65	875	6.15	905	6.55	940	7.05	970	7.50	1000	8.00	1030	8.50
7500	765	5.05	795	5.45	825	5.85	855	6.30	885	6.75	915	7.20	945	7.65	975	8.15	---	---	---	---	---	---
8000	815	6.10	845	6.55	870	6.95	900	7.45	930	7.95	955	8.35	---	---	---	---	---	---	---	---	---	---
8500	865	7.30	895	7.80	920	8.25	---	---	---	---	---	---	---	---	---	---	---	---	---	---	---	---

POWER EXHAUST BLOWERS

¹ 100% HIGH STATIC OPERATION, NO ERW

Air Volume cfm	Return Duct Negative Static Pressure - Inches Water Gauge (Pa)																					
	0		0.1		0.2		0.3		0.4		0.5		0.6		0.7		0.8		0.9		1.0	
	RPM	BHP	RPM	BHP	RPM	BHP	RPM	BHP	RPM	BHP	RPM	BHP	RPM	BHP	RPM	BHP	RPM	BHP	RPM	BHP	RPM	BHP
8000	410	1.45	450	1.70	495	2.05	535	2.35	580	2.70	625	3.10	665	3.50	710	3.95	750	4.40	790	4.85	835	5.35
8500	435	1.70	475	2.00	515	2.35	555	2.70	595	3.05	635	3.45	675	3.85	715	4.30	755	4.75	795	5.25	835	5.75
9000	460	2.05	495	2.35	535	2.70	575	3.05	610	3.40	650	3.85	690	4.30	725	4.70	765	5.20	800	5.65	840	6.20
9500	485	2.40	520	2.70	555	3.05	595	3.45	630	3.85	665	4.25	700	4.70	740	5.20	775	5.65	810	6.15	845	6.65
10,000	510	2.80	545	3.15	580	3.50	615	3.90	650	4.35	680	4.70	715	5.15	750	5.65	785	6.15	820	6.65	855	7.20
10,500	535	3.20	570	3.60	600	3.95	635	4.40	665	4.80	700	5.25	730	5.70	765	6.20	795	6.65	830	7.20	860	7.70
11,000	560	3.70	590	4.05	625	4.50	655	4.90	685	5.35	720	5.85	750	6.30	780	6.75	810	7.25	840	7.75	875	8.40
11,500	585	4.20	615	4.60	645	5.05	675	5.45	705	5.90	735	6.40	765	6.90	795	7.40	825	7.90	855	8.45	885	9.00
12,000	610	4.80	640	5.20	670	5.70	700	6.15	725	6.55	755	7.05	785	7.60	815	8.10	840	8.60	870	9.15	900	9.75
12,500	635	5.40	665	5.90	690	6.30	720	6.80	750	7.30	775	7.75	805	8.30	830	8.80	860	9.40	885	9.90	915	10.55
13,000	660	6.10	690	6.60	715	7.00	740	7.45	770	8.05	795	8.50	820	9.00	850	9.65	875	10.15	900	10.70	930	11.35
13,500	690	6.90	715	7.35	740	7.80	765	8.30	790	8.80	815	9.30	840	9.85	865	10.40	895	11.05	920	11.65	945	12.20
14,000	715	7.65	740	8.15	765	8.65	785	9.10	810	9.60	835	10.15	860	10.70	885	11.30	910	11.90	935	12.50	960	13.10
14,500	740	8.50	765	9.05	785	9.45	810	10.00	835	10.60	860	11.20	880	11.65	905	12.25	930	12.90	955	13.55	975	14.05
15,000	765	9.40	785	9.85	810	10.45	835	11.05	855	11.50	880	12.15	905	12.75	925	13.30	950	13.95	970	14.50	995	15.20
15,500	790	10.35	810	10.85	835	11.45	855	11.95	880	12.60	900	13.15	925	13.80	945	14.35	970	15.05	990	15.65	1015	16.35
16,000	815	11.40	835	11.90	860	12.55	880	13.10	900	13.65	925	14.35	945	14.90	965	15.50	990	16.20	1010	16.85	---	---
16,500	840	12.50	860	13.05	885	13.70	905	14.30	925	14.85	945	15.45	965	16.05	990	16.80	---	---	---	---	---	---
17,000	865	13.65	885	14.20	905	14.80	925	15.40	950	16.15	970	16.80	---	---	---	---	---	---	---	---	---	---
17,500	890	14.85	910	15.50	930	16.10	950	16.75	---	---	---	---	---	---	---	---	---	---	---	---	---	---
18,000	915	16.15	935	16.80	---	---	---	---	---	---	---	---	---	---	---	---	---	---	---	---	---	---

NOTE - See page 61 for factory installed drive kit specifications.

¹ Size power exhaust blowers in economizer mode to minimize building static pressure during free^o cooling.

BLOWER DATA

POWER EXHAUST BLOWERS

¹ 50% HIGH STATIC OPERATION WITH ERW (BY-PASS DAMPERS CLOSED)

Air Volume cfm	Return Duct Negative Static Pressure - Inches Water Gauge (Pa)																					
	0		0.1		0.2		0.3		0.4		0.5		0.6		0.7		0.8		0.9		1.0	
	RPM	BHP	RPM	BHP	RPM	BHP	RPM	BHP	RPM	BHP	RPM	BHP	RPM	BHP	RPM	BHP	RPM	BHP	RPM	BHP	RPM	BHP
2500	390	0.35	460	0.50	530	0.70	600	0.90	670	1.15	735	1.40	805	1.70	870	2.00	935	2.35	1005	2.75	1070	3.10
3000	465	0.60	525	0.75	585	1.00	645	1.20	700	1.45	760	1.75	815	2.05	870	2.35	930	2.70	985	3.05	1040	3.45
3500	545	0.95	595	1.15	645	1.35	695	1.60	745	1.90	795	2.20	845	2.50	895	2.85	945	3.20	990	3.55	1040	3.95
4000	620	1.35	665	1.60	710	1.90	755	2.15	800	2.45	840	2.75	885	3.10	930	3.45	975	3.80	1015	4.15	1060	4.60
4500	700	1.95	740	2.25	780	2.55	820	2.85	855	3.10	895	3.45	935	3.80	975	4.20	1015	4.60	1050	4.95	---	---
5000	775	2.70	815	3.00	850	3.30	885	3.65	920	4.00	955	4.35	990	4.70	1025	5.10	1060	5.50	---	---	---	---
5500	855	3.60	885	3.90	920	4.25	950	4.60	985	5.00	1015	5.35	1050	5.75	---	---	---	---	---	---	---	---
6000	935	4.70	965	5.05	990	5.35	1020	5.75	1050	6.15	---	---	---	---	---	---	---	---	---	---	---	---

POWER EXHAUST BLOWERS

¹ 100% HIGH STATIC OPERATION WITH ERW (BY-PASS DAMPERS CLOSED)

Air Volume cfm	Return Duct Negative Static Pressure - Inches Water Gauge (Pa)																					
	0		0.1		0.2		0.3		0.4		0.5		0.6		0.7		0.8		0.9		1.0	
	RPM	BHP	RPM	BHP	RPM	BHP	RPM	BHP	RPM	BHP	RPM	BHP	RPM	BHP	RPM	BHP	RPM	BHP	RPM	BHP	RPM	BHP
5000	445	0.85	505	1.15	565	1.45	625	1.85	680	2.20	740	2.65	800	3.15	855	3.60	910	4.15	970	4.75	1025	5.30
5500	490	1.15	545	1.45	600	1.80	650	2.15	705	2.55	760	3.05	810	3.50	865	4.00	915	4.55	970	5.15	1020	5.70
6000	535	1.45	585	1.80	635	2.15	685	2.60	735	3.00	780	3.45	830	3.95	880	4.50	925	5.00	975	5.60	1020	6.15
6500	580	1.85	625	2.20	670	2.60	715	3.00	760	3.45	805	3.95	850	4.45	895	4.95	940	5.50	985	6.10	1030	6.75
7000	625	2.35	665	2.70	710	3.15	750	3.55	795	4.05	835	4.50	880	5.05	920	5.60	960	6.15	1005	6.80	1045	7.40
7500	670	2.90	710	3.30	750	3.75	790	4.20	825	4.65	865	5.15	905	5.70	945	6.25	985	6.85	1025	7.50	1060	8.05
8000	715	3.50	750	3.90	790	4.40	825	4.85	860	5.35	900	5.90	935	6.45	975	7.05	1010	7.65	1045	8.25	---	---
8500	760	4.20	795	4.65	830	5.15	865	5.65	900	6.20	935	6.75	970	7.30	1000	7.85	1035	8.45	1070	9.10	---	---
9000	800	4.90	835	5.45	870	5.95	900	6.45	935	7.05	970	7.65	1000	8.20	1035	8.85	1065	9.40	---	---	---	---
9500	845	5.80	880	6.35	910	6.85	940	7.40	975	8.05	1005	8.60	1035	9.20	1065	9.80	---	---	---	---	---	---
10,000	890	6.75	920	7.30	950	7.85	980	8.45	1010	9.05	1040	9.65	1070	10.30	---	---	---	---	---	---	---	---
10,500	935	7.85	965	8.45	995	9.05	1020	9.60	1050	10.25	---	---	---	---	---	---	---	---	---	---	---	---
11,000	980	9.00	1010	9.65	1035	10.25	1060	10.80	---	---	---	---	---	---	---	---	---	---	---	---	---	---
11,500	1025	10.30	1050	10.90	---	---	---	---	---	---	---	---	---	---	---	---	---	---	---	---	---	---
12,000	1070	11.75	---	---	---	---	---	---	---	---	---	---	---	---	---	---	---	---	---	---	---	---

NOTE - See page 61 for factory installed drive kit specifications.

¹ Size power exhaust blowers with ERW in economizer mode to minimize building static pressure during free" cooling.

BLOWER DATA

POWER EXHAUST BLOWERS

¹ 50% HIGH STATIC OPERATION WITH ERW IN ECONOMIZER MODE (BY-PASS DAMPERS OPEN)

Air Volume cfm	Return Duct Negative Static Pressure - Inches Water Gauge (Pa)																					
	0		0.1		0.2		0.3		0.4		0.5		0.6		0.7		0.8		0.9		1.0	
	RPM	BHP	RPM	BHP	RPM	BHP	RPM	BHP	RPM	BHP	RPM	BHP	RPM	BHP	RPM	BHP	RPM	BHP	RPM	BHP	RPM	BHP
3500	380	0.55	435	0.70	495	0.90	555	1.10	615	1.35	675	1.60	730	1.85	790	2.15	845	2.45	900	2.80	960	3.15
4000	430	0.80	485	1.00	535	1.20	585	1.40	640	1.65	690	1.95	740	2.20	790	2.50	845	2.85	895	3.20	945	3.55
4500	485	1.10	530	1.30	575	1.55	625	1.80	670	2.05	715	2.35	760	2.65	805	2.95	855	3.30	900	3.65	945	4.00
5000	540	1.55	580	1.75	620	2.00	665	2.30	705	2.55	745	2.85	790	3.20	830	3.50	870	3.85	910	4.15	950	4.55
5500	590	2.05	630	2.30	670	2.60	705	2.85	745	3.15	780	3.45	820	3.80	855	4.10	895	4.50	930	4.80	970	5.25
6000	645	2.65	680	2.90	715	3.20	750	3.50	785	3.85	820	4.15	855	4.50	890	4.85	925	5.25	960	5.65	995	6.05
6500	700	3.35	730	3.65	765	4.00	795	4.30	830	4.65	860	5.00	890	5.30	925	5.70	955	6.10	990	6.50	1020	6.90
7000	755	4.20	785	4.55	815	4.90	845	5.20	875	5.60	905	5.95	935	6.35	960	6.65	990	7.05	1020	7.45	1050	7.90
7500	805	5.15	835	5.50	865	5.90	890	6.20	920	6.60	945	6.95	975	7.40	1000	7.75	1030	8.20	1060	8.65	---	---
8000	860	6.25	885	6.60	915	7.05	940	7.40	965	7.80	990	8.15	1020	8.65	1045	9.05	1070	9.45	---	---	---	---
8500	915	7.55	940	7.90	965	8.35	990	8.75	1015	9.15	1040	9.60	1060	9.95	---	---	---	---	---	---	---	---

POWER EXHAUST BLOWERS

¹ 100% HIGH STATIC OPERATION WITH ERW IN ECONOMIZER MODE (BY-PASS DAMPERS OPEN)

Air Volume cfm	Return Duct Negative Static Pressure - Inches Water Gauge (Pa)																					
	0		0.1		0.2		0.3		0.4		0.5		0.6		0.7		0.8		0.9		1.0	
	RPM	BHP	RPM	BHP	RPM	BHP	RPM	BHP	RPM	BHP	RPM	BHP	RPM	BHP	RPM	BHP	RPM	BHP	RPM	BHP	RPM	BHP
7000	415	1.15	470	1.50	520	1.80	570	2.10	620	2.50	675	2.90	725	3.35	775	3.80	825	4.30	875	4.80	925	5.35
7500	445	1.45	495	1.75	540	2.05	590	2.45	640	2.85	685	3.25	735	3.70	780	4.15	825	4.65	875	5.20	920	5.70
8000	475	1.75	520	2.05	565	2.40	610	2.80	655	3.20	700	3.65	745	4.10	790	4.55	835	5.10	880	5.60	920	6.10
8500	505	2.10	545	2.40	590	2.80	635	3.25	675	3.60	715	4.05	760	4.55	800	5.00	845	5.55	885	6.05	925	6.60
9000	535	2.50	575	2.85	615	3.25	655	3.65	695	4.10	735	4.55	775	5.00	815	5.50	855	6.05	895	6.60	935	7.15
9500	565	2.95	600	3.30	640	3.70	680	4.15	715	4.55	755	5.05	790	5.50	830	6.05	870	6.60	905	7.15	945	7.75
10,000	595	3.45	630	3.80	665	4.20	700	4.65	740	5.15	775	5.65	810	6.10	845	6.65	880	7.15	920	7.80	955	8.35
10,500	625	4.00	660	4.40	690	4.80	725	5.25	760	5.75	795	6.25	830	6.75	865	7.30	900	7.90	935	8.50	965	9.00
11,000	655	4.60	685	4.95	720	5.45	750	5.90	785	6.40	820	6.95	850	7.45	885	8.05	915	8.55	950	9.20	980	9.75
11,500	680	5.15	715	5.65	745	6.10	775	6.60	810	7.15	840	7.65	870	8.20	905	8.80	935	9.40	965	9.95	995	10.55
12,000	710	5.85	740	6.35	775	6.90	805	7.40	835	7.95	865	8.50	895	9.05	925	9.65	955	10.25	985	10.85	1015	11.50
12,500	740	6.65	770	7.15	800	7.70	830	8.25	860	8.80	885	9.30	915	9.90	945	10.50	975	11.15	1005	11.80	1030	12.35
13,000	770	7.50	800	8.05	825	8.50	855	9.10	885	9.70	910	10.20	940	10.85	965	11.40	995	12.10	1020	12.65	1050	13.40
13,500	800	8.40	830	9.00	855	9.50	880	10.00	910	10.65	935	11.20	965	11.90	990	12.50	1015	13.10	1045	13.85	---	---
14,000	830	9.35	855	9.90	885	10.55	910	11.10	935	11.70	960	12.30	985	12.90	1010	13.50	1040	14.25	1065	14.90	---	---
14,500	860	10.40	885	11.00	910	11.55	935	12.15	960	12.75	985	13.40	1010	14.05	1035	14.70	1060	15.40	---	---	---	---
15,000	890	11.55	915	12.15	940	12.75	965	13.40	985	13.95	1010	14.60	1035	15.30	1060	16.00	---	---	---	---	---	---
15,500	920	12.75	945	13.40	965	13.90	990	14.60	1015	15.30	1035	15.85	1060	16.60	---	---	---	---	---	---	---	---
16,000	950	14.00	970	14.55	995	15.25	1020	16.00	1040	16.60	1065	17.35	---	---	---	---	---	---	---	---	---	---
16,500	980	15.35	1000	15.95	1025	16.70	1045	17.30	1065	17.95	---	---	---	---	---	---	---	---	---	---	---	---
17,000	1010	16.80	1030	17.45	1050	18.10	---	---	---	---	---	---	---	---	---	---	---	---	---	---	---	---

NOTE - See page 61 for factory installed drive kit specifications.

¹ Size power exhaust blowers with ERW in economizer mode to minimize building static pressure during free" cooling.

BLOWER DATA

POWER EXHAUST BLOWERS

STANDARD STATIC (1 TWO BLOWER OPERATION)

Return Duct Negative Static Pressure Inches Water Gauge	Air Volume cfm	Return Duct Negative Static Pressure Inches Water Gauge	Air Volume cfm
0	12,100	0.50	5700
0.05	11,600	0.55	5000
0.10	11,150	0.60	4300
0.15	10,600	0.65	3800
0.20	10,100	0.70	3400
0.25	9500	0.75	3000
0.30	8900	0.80	2500
0.35	8200	0.85	2300
0.40	7400	0.90	2000
0.45	6500		

¹ For one blower operation, use half of the air volume value.

OUTDOOR AIR PERCENTAGE VS. FRESH AIR DAMPER ANGLE - Less ERW

Fresh Air Damper Opening Angle	Percentage of Outdoor Air Available at Various Return Duct Static Pressures - in. w.g.			
	0.2	0.4	0.6	0.8
10°	5%	11%	16%	21%
20°	19%	25%	30%	36%
30°	34%	39%	44%	50%
40°	48%	53%	59%	64%
50°	62%	68%	73%	79%
60°	77%	82%	87%	93%
70°	91%	96%	100%	100%
80°	100%	100%	100%	100%

NOTE - Outdoor air percentage will vary when a variable frequency drive (VFD) drive is used on the supply air blower.

OUTDOOR AIR PERCENTAGE VS. FRESH AIR DAMPER ANGLE - With ERW

¹ ERW Static Pressure in. w.g.	Percentage of Outdoor Air Available at Various Return Duct Static Pressures																		
	0 Return Duct Static						0.2 Return Duct Static						0.4 Return Duct Static						
	1.2	1.0	0.8	0.6	0.4	0.2	1.2	1.0	0.8	0.6	0.4	0.2	1.2	1.0	0.8	0.6	0.4	0.2	
Fresh Air Damper Opening Angle	10°	---	---	---	---	---	---	---	---	---	---	---	---	---	---	---	---	---	
	20°	9%	4%	---	---	---	---	14%	9%	4%	---	---	---	19%	14%	9%	4%	---	
	30°	23%	18%	13%	8%	2%	---	28%	23%	18%	13%	8%	2%	34%	28%	23%	18%	13%	8%
	40°	38%	32%	27%	22%	17%	11%	43%	38%	32%	27%	22%	17%	48%	43%	38%	32%	27%	22%
	50°	52%	46%	41%	36%	31%	25%	57%	52%	46%	41%	36%	31%	62%	57%	52%	46%	41%	36%
	60°	66%	61%	55%	50%	45%	39%	71%	66%	61%	55%	50%	45%	77%	71%	66%	61%	55%	50%
	70°	81%	75%	70%	64%	59%	54%	86%	81%	75%	70%	64%	59%	91%	86%	81%	75%	70%	64%
	80°	95%	89%	84%	78%	73%	68%	100%	95%	89%	84%	78%	73%	100%	100%	95%	89%	84%	78%
¹ ERW Static Pressure in. w.g.	Percentage of Outdoor Air Available at Various Return Duct Static Pressures																		
	0.6 Return Duct Static							0.8 Return Duct Static											
	1.2	1.0	0.8	0.6	0.4	0.2	1.2	1.0	0.8	0.6	0.4	0.2							
Fresh Air Damper Opening Angle	10°	---	---	---	---	---	---	---	---	---	---	---	---	---	---	---	---	---	---
	20°	25%	19%	14%	9%	4%	---	30%	25%	19%	14%	9%	4%	---	---	---	---	---	---
	30°	39%	34%	28%	23%	18%	13%	44%	39%	34%	28%	23%	18%	---	---	---	---	---	---
	40°	54%	48%	43%	38%	32%	27%	59%	54%	48%	43%	38%	32%	---	---	---	---	---	---
	50°	68%	62%	57%	52%	46%	41%	73%	68%	62%	57%	52%	46%	---	---	---	---	---	---
	60°	84%	77%	71%	66%	61%	55%	87%	84%	77%	71%	66%	61%	---	---	---	---	---	---
	70°	97%	91%	86%	81%	75%	70%	100%	97%	91%	86%	81%	75%	---	---	---	---	---	---
	80°	100%	100%	100%	95%	89%	84%	100%	100%	100%	100%	95%	89%	---	---	---	---	---	---

NOTE - Outdoor air percentage will vary when a variable frequency drive (VFD) drive is used on the supply air blower.

¹ See page 62 for Energy Recovery Wheel Specifications.

BLOWER DATA**AIR RESISTANCE****HORIZONTAL AIRFLOW APPLICATIONS**

Air Volume	Standard Static Power Exhaust Fans or No Power Exhaust Fans	50% High Static Power Exhaust Blowers	100% High Static Power Exhaust Blowers
cfm	in. w.g.	in. w.g.	in. w.g.
10,000	.20	.23	.25
10,500	.20	.25	.30
11,000	.20	.25	.30
11,500	.20	.30	.40
12,000	.20	.33	.45
12,500	.20	.35	.50
13,000	.20	.38	.55
13,500	.25	.43	.60
14,000	.25	.45	.65
14,500	.25	.48	.70
15,000	.30	.55	.80
15,500	.30	.58	.85
16,000	.30	.63	.95
16,500	.30	.63	.95
17,000	.30	.68	1.05
17,500	.30	.70	1.10
18,000	.30	.75	1.20
18,500	.30	.78	1.25
19,000	.30	.83	1.35
19,500	.30	.83	1.40
20,000	.30	.90	1.50
20,500	.35	.94	1.60
21,000	.35	.98	1.70
21,500	.35	1.02	1.80
22,000	.35	1.04	1.90
22,500	.35	1.10	2.00

BLOWER DATA

FACTORY INSTALLED OPTIONS ACCESSORY AIR RESISTANCE

ECONOMIZER RETURN AIR DAMPER WITH ERW

Outdoor Air Volume With ERW cfm	Return Duct Negative Static Pressure 0 in. w.g.				
	0.2	0.4	0.6	0.8	1.0
3250	0.32	0.12	---	---	---
3500	0.36	0.16	---	---	---
3750	0.40	0.20	---	---	---
4000	0.44	0.24	0.04	---	---
4250	0.48	0.28	0.08	---	---
4500	0.52	0.32	0.12	---	---
4750	0.57	0.37	0.17	---	---
5000	0.60	0.40	0.20	---	---
5250	0.65	0.45	0.25	0.05	---
5500	0.68	0.48	0.28	0.08	---
5750	0.73	0.53	0.33	0.13	---
6000	0.76	0.56	0.36	0.16	---
6250	0.81	0.61	0.41	0.21	0.01
6500	0.84	0.64	0.44	0.24	0.04
6750	0.89	0.69	0.49	0.29	0.09
7000	0.93	0.73	0.53	0.33	0.13
7250	0.97	0.77	0.57	0.37	0.17
7500	1.01	0.81	0.61	0.41	0.21
7750	1.05	0.85	0.65	0.45	0.25
8000	1.09	0.89	0.69	0.49	0.29
8250	1.13	0.93	0.73	0.53	0.33
8500	1.17	0.97	0.77	0.57	0.37
8750	1.21	1.01	0.81	0.61	0.41
9000	1.25	1.05	0.85	0.65	0.45

FACTORY INSTALLED OPTIONS ACCESSORY AIR RESISTANCE

Air Volume cfm	Wet Indoor Coil	Humiditrol® Condenser Reheat Coil	Electric Heat	Economizer	Filters			
					MERV 8		MERV 13	
					2 inch	4 inch	2 inch	4 inch
in. w.g.	in. w.g.	in. w.g.	in. w.g.	in. w.g.	in. w.g.	in. w.g.	in. w.g.	
8000	0.16	---	0.07	---	0.03	0.05	0.11	0.06
9000	0.21	---	0.07	---	0.03	0.05	0.13	0.07
10,000	0.25	---	0.07	0.02	0.04	0.06	0.14	0.08
11,000	0.29	---	0.07	0.08	0.04	0.06	0.16	0.08
12,000	0.32	---	0.07	0.12	0.05	0.07	0.17	0.09
13,000	0.37	---	0.07	0.17	0.05	0.07	0.18	0.10
14,000	0.42	0.01	0.07	0.19	0.05	0.08	0.20	0.11
15,000	0.46	0.01	0.08	0.22	0.06	0.09	0.21	0.11
16,000	0.51	0.02	0.09	0.23	0.06	0.09	0.23	0.12
17,000	0.56	0.04	0.10	0.25	0.06	0.10	0.24	0.13
18,000	0.60	0.06	0.13	0.26	0.07	0.10	0.26	0.14
19,000	0.68	0.09	0.14	0.26	0.07	0.11	0.27	0.14
20,000	0.70	0.11	0.18	0.26	0.07	0.11	0.28	0.15
21,000	0.78	0.15	0.20	0.26	0.08	0.12	0.30	0.16
22,000	0.82	0.19	0.21	0.26	0.08	0.12	0.31	0.17

BLOWER DRIVE KITS

DRIVE KIT SPECIFICATIONS

Nominal hp	Maximum hp	Drive Kit Number	RPM Range (Adjustable Pulley)
5	5.75	1	510 - 640
		2	630 - 760
7.5	8.63	3	635 - 770
		4	750 - 905
10	11.5	5	670 - 825
		4	750 - 905
		6	880 - 1050
15	17.25	7	745 - 900
		8	875 - 1045
		9	965 - 1190
20	23	10	825 - 1020
		11	1010 - 1240
25	28.75	12	930 - 1085
		13	1075 - 1285
30	34.5	13	1075 - 1285
		14	1150 - 1340

NOTE - Using total air volume and system static pressure requirements determine from blower performance tables rpm and motor output required. Maximum usable output of motors furnished are shown. In Canada, nominal motor hp is also maximum usable motor hp. If motors of comparable output are used, be sure to keep within the service factor limitations outlined on the motor nameplate.

For Variable Frequency Drive applications, nominal motor output is also maximum usable motor output.

HIGH STATIC POWER EXHAUST BLOWERS - DRIVE KIT SPECIFICATIONS

Nominal hp per blower	¹ Maximum hp per blower	RPM Range ³ Adjustable	Drive Kit Number		
			50% Applications Rear Position	² 100% Applications Order One Each:	
				Front Position	Rear Position
3	3.45	735-920	6(A)-B35	6(B)-B36	6(A)-B35
		690-845	5(A)-B35	5(B)-B36	5(A)-B35
5	5.75	795-975	3(A)-B35	3(B)-B36	3(A)-B35
		735-920	4(A)-B35	4(B)-B36	4(A)-B35
7.5	8.63	850-1065	1(A)-B35	1(B)-B36	1(A)-B35
		820-980	2(A)-B35	2(B)-B36	2(A)-B35

¹ In VFD applications, nominal motor output is also maximum usable motor output.

² Two drive kits are required for the same rpm, one for the front blower position and one for the rear blower position because of different belt length requirements.

³ Adjustable motor pulleys are factory set for maximum RPM in VFD applications.

ENERGY RECOVERY WHEEL SPECIFICATIONS

¹ Enthalpy Wheel AHRI Rating Data	Nominal Airflow		6600 cfm		
	EATR - Exhaust Air Transfer Ratio	at minus 1 in. w. c.	4.6%		
		at 0 in. w.c.	1.9%		
		at 1 in. w.c.	0.9%		
	OACF Outdoor Air Correction Factor	at minus 1 in. w. c.	0.99%		
		at 0 in. w.c.	1.05%		
at 1 in. w.c.		1.08%			
¹ Thermal Ratings at 0.95 in. w.c. Pressure Differential	Total Effectiveness	100% Airflow Heating	Sensible	Latent	Total
		75% Airflow Heating	68	60	65
	100% Airflow Cooling	75% Airflow Heating	73	67	71
		75% Airflow Cooling	68	60	63
	Net Effectiveness	100% Airflow Heating	73	67	70
		100% Airflow Cooling	68	60	63
Dimensions	diameter x width - in. (mm)	63 x 3 (1600 x 76)			

¹ Rated in accordance with AHRI Standard 1060-2001. For further information, please reference AHRI 1060-2005 Standard For Rating Air-to-Air Heat Exchangers For Energy Recovery Ventilation Equipment.

EFFECTIVENESS

Air Flow cfm	Static Pressure in. w.c.	Effectiveness (%)			
		Sensible	Latent	Total	
				Cooling	Heating
3250	0.45	79.7	75.1	76.9	78.0
3500	0.48	78.8	73.9	75.9	77.0
3750	0.52	77.9	72.8	74.9	76.1
4000	0.55	77.0	71.7	73.8	54.1
4250	0.59	76.1	70.6	72.8	74.1
4500	0.62	75.3	69.4	71.8	73.2
4750	0.66	74.4	68.3	70.7	72.2
5000	0.69	73.5	67.2	69.7	71.2
5250	0.73	72.6	66.1	68.7	70.3
5500	0.76	71.8	64.9	67.7	69.3
5750	0.80	70.9	63.8	66.6	68.3
6000	0.83	70.0	62.7	65.6	67.4
6250	0.87	69.1	61.6	64.6	66.4
6500	0.90	68.2	60.4	63.5	65.4
6750	0.94	67.4	59.3	62.5	64.5
7000	0.97	66.5	58.2	61.5	63.5
7250	1.01	65.6	57.1	60.4	62.5
7500	1.04	64.7	55.9	59.4	61.6
7750	1.08	63.8	54.8	58.4	60.6
8000	1.11	62.9	53.6	57.3	59.6
8250	1.15	62.0	52.5	56.3	58.7
8500	1.18	61.1	51.4	55.2	57.7
8750	1.22	60.3	50.2	54.2	56.7
9000	1.25	59.4	49.1	53.1	55.7

ELECTRICAL DATA

STANDARD EFFICIENCY - 35 TON (208/230V-3Ph)

		Model No.	LCH420S4						
¹ Voltage - 60hz			208/230V-3Ph						
Compressor 1		Rated Load Amps	29.5						
		Locked Rotor Amps	195						
Compressor 2		Rated Load Amps	29.5						
		Locked Rotor Amps	195						
Compressor 3		Rated Load Amps	29.5						
		Locked Rotor Amps	195						
Compressor 4		Rated Load Amps	29.5						
		Locked Rotor Amps	195						
Outdoor Fan Motors (6)		Full Load Amps (total)	3.7 (22.2)						
Service Outlet 115V GFI (amps)			15						
Indoor Blower Motor		Horsepower	5	7.5	10	15	20	25	30
		Full Load Amps	16.7	24.2	30.8	46.2	59.4	74.8	78
² Maximum Overcurrent Protection	Unit Only		175	200	200	225	250	⁴ 300	⁴ 300
	Power Exhaust	50% Standard Static (1) 1 hp motor	200	200	200	250	250	⁴ 300	⁴ 300
		100% Standard Static (2) 1 hp motor	200	200	200	250	250	⁴ 300	⁴ 300
		50% High Static (1) 3 hp motor	200	200	200	250	250	⁴ 300	⁴ 300
		100% High Static (2) 3 hp motor	200	200	225	250	250	⁴ 300	⁴ 300
		50% High Static (1) 5 hp motor	200	200	225	250	250	⁴ 300	⁴ 300
		100% High Static (2) 5 hp motor	225	225	225	250	⁴ 300	⁴ 300	⁴ 350
		50% High Static (1) 7.5 hp motor	200	225	225	250	⁴ 300	⁴ 300	⁴ 300
		100% High Static (2) 7.5 hp motor	225	250	250	250	⁴ 300	⁴ 350	⁴ 350
³ Minimum Circuit Ampacity	Unit Only		167	175	181	201	217	236	240
	Power Exhaust	50% Standard Static (1) 1 hp motor	172	179	186	206	222	241	245
		100% Standard Static (2) 1 hp motor	177	184	191	210	227	246	250
		50% High Static (1) 3 hp motor	178	185	192	211	228	247	251
		100% High Static (2) 3 hp motor	188	196	203	222	238	258	262
		50% High Static (1) 5 hp motor	184	191	198	217	234	253	257
		100% High Static (2) 5 hp motor	200	208	215	234	251	270	274
		50% High Static (1) 7.5 hp motor	191	199	205	221	234	249	253
		100% High Static (2) 7.5 hp motor	215	223	230	249	266	285	289

NOTE - All units have a minimum Short Circuit Current Rating (SCCR) of 5000 amps.

¹ Extremes of operating range are plus and minus 10% of line voltage.

² HACR type breaker or fuse.

³ Refer to National or Canadian Electrical Code manual to determine wire, fuse and disconnect size requirements.

⁴ Factory installed circuit breaker not available.

ELECTRICAL DATA

STANDARD EFFICIENCY - 35 TON (460V-3Ph)

		Model No.	LCH420S4						
¹ Voltage - 60hz			460V-3Ph						
Compressor 1		Rated Load Amps	14.8						
		Locked Rotor Amps	95						
Compressor 2		Rated Load Amps	14.8						
		Locked Rotor Amps	95						
Compressor 3		Rated Load Amps	14.8						
		Locked Rotor Amps	95						
Compressor 4		Rated Load Amps	14.8						
		Locked Rotor Amps	95						
Outdoor Fan Motors (6)		Full Load Amps	1.9						
		(total)	(11.4)						
Service Outlet 115V GFI (amps)			15						
Indoor Blower Motor		Horsepower	5	7.5	10	15	20	25	30
		Full Load Amps	7.6	11	14	21	27	34	35
² Maximum Overcurrent Protection	Unit Only		90	100	100	110	125	125	150
	Power Exhaust	50% Standard Static (1) 1 hp motor	100	100	100	110	125	150	150
		100% Standard Static (2) 1 hp motor	100	100	100	110	125	150	150
		50% High Static (1) 3 hp motor	100	100	100	110	125	150	150
		100% High Static (2) 3 hp motor	100	100	100	110	125	150	150
		50% High Static (1) 5 hp motor	100	100	110	125	125	150	150
		100% High Static (2) 5 hp motor	110	110	110	125	125	150	150
		50% High Static (1) 7.5 hp motor	100	110	110	125	125	150	150
		100% High Static (2) 7.5 hp motor	125	125	125	125	150	150	150
	³ Minimum Circuit Ampacity	Unit Only		84	87	90	99	106	115
Power Exhaust		50% Standard Static (1) 1 hp motor	86	89	92	101	108	117	118
		100% Standard Static (2) 1 hp motor	88	92	95	103	111	120	121
		50% High Static (1) 3 hp motor	88	92	95	103	111	120	121
		100% High Static (2) 3 hp motor	93	97	100	108	116	124	126
		50% High Static (1) 5 hp motor	91	95	98	106	114	122	124
		100% High Static (2) 5 hp motor	99	102	105	114	121	130	131
		50% High Static (1) 7.5 hp motor	95	98	101	110	117	126	127
		100% High Static (2) 7.5 hp motor	106	109	112	121	128	137	138

NOTE - All units have a minimum Short Circuit Current Rating (SCCR) of 5000 amps.

¹ Extremes of operating range are plus and minus 10% of line voltage.

² HACR type breaker or fuse.

³ Refer to National or Canadian Electrical Code manual to determine wire, fuse and disconnect size requirements.

ELECTRICAL DATA

STANDARD EFFICIENCY - 35 TON (575V-3Ph)

		Model No.	LCH420S4						
¹ Voltage - 60hz			575V-3Ph						
Compressor 1		Rated Load Amps	12.2						
		Locked Rotor Amps	80						
Compressor 2		Rated Load Amps	12.2						
		Locked Rotor Amps	80						
Compressor 3		Rated Load Amps	12.2						
		Locked Rotor Amps	80						
Compressor 4		Rated Load Amps	12.2						
		Locked Rotor Amps	80						
Outdoor Fan Motors (6)		Full Load Amps	1.6						
		(total)	(9.6)						
Service Outlet 115V GFI (amps)			20						
Indoor Blower Motor		Horsepower	5	7.5	10	15	20	25	30
		Full Load Amps	6.1	9	11	17	22	27	32
² Maximum Overcurrent Protection	Unit Only		80	80	80	90	100	110	125
	Power Exhaust	50% Standard Static (1) 1 hp motor	80	80	80	90	110	110	125
		100% Standard Static (2) 1 hp motor	80	80	80	100	110	110	125
		50% High Static (1) 3 hp motor	80	80	80	100	110	110	125
		100% High Static (2) 3 hp motor	80	90	90	100	110	125	125
		50% High Static (1) 5 hp motor	80	80	90	100	110	125	125
		100% High Static (2) 5 hp motor	90	90	90	100	110	125	125
		50% High Static (1) 7.5 hp motor	80	90	90	100	110	125	125
		100% High Static (2) 7.5 hp motor	90	100	100	110	125	125	125
³ Minimum Circuit Ampacity	Unit Only		69	72	74	81	87	94	100
	Power Exhaust	50% Standard Static (1) 1 hp motor	71	74	76	83	89	96	102
		100% Standard Static (2) 1 hp motor	73	76	78	85	91	98	104
		50% High Static (1) 3 hp motor	73	76	78	85	91	98	104
		100% High Static (2) 3 hp motor	77	80	82	89	95	101	108
		50% High Static (1) 5 hp motor	75	78	80	87	93	100	106
		100% High Static (2) 5 hp motor	81	84	86	93	100	106	112
		50% High Static (1) 7.5 hp motor	78	81	83	90	96	103	109
		100% High Static (2) 7.5 hp motor	87	90	92	99	105	112	118

NOTE - All units have a minimum Short Circuit Current Rating (SCCR) of 5000 amps.

¹ Extremes of operating range are plus and minus 10% of line voltage.

² HACR type breaker or fuse.

³ Refer to National or Canadian Electrical Code manual to determine wire, fuse and disconnect size requirements.

ELECTRICAL DATA

HIGH EFFICIENCY - 35 TON (208/230V-3Ph)

Model No.		LCH420H4							
¹ Voltage - 60hz		208/230V-3Ph							
Compressor 1	Rated Load Amps	29.5							
	Locked Rotor Amps	195							
Compressor 2	Rated Load Amps	29.5							
	Locked Rotor Amps	195							
Compressor 3	Rated Load Amps	29.5							
	Locked Rotor Amps	195							
Compressor 4	Rated Load Amps	29.5							
	Locked Rotor Amps	195							
Outdoor Fan Motors (6)	Full Load Amps (total)	4.8 (28.8)							
Service Outlet 115V GFI (amps)		15							
Indoor Blower Motor	Horsepower	5	7.5	10	15	20	25	30	
	Full Load Amps	16.7	24.2	30.8	46.2	59.4	74.8	78	
² Maximum Overcurrent Protection	Unit Only		200	200	200	250	250	⁴ 300	⁴ 300
	Power Exhaust	50% Standard Static (1) 1 hp motor	200	200	200	250	250	⁴ 300	⁴ 300
		100% Standard Static (2) 1 hp motor	200	200	225	250	250	⁴ 300	⁴ 300
		50% High Static (1) 3 hp motor	200	200	225	250	250	⁴ 300	⁴ 300
		100% High Static (2) 3 hp motor	200	225	225	250	⁴ 300	⁴ 300	⁴ 300
		50% High Static (1) 5 hp motor	200	225	225	250	250	⁴ 300	⁴ 300
		100% High Static (2) 5 hp motor	225	225	250	250	⁴ 300	⁴ 350	⁴ 350
		50% High Static (1) 7.5 hp motor	225	225	225	250	⁴ 300	⁴ 300	⁴ 300
		100% High Static (2) 7.5 hp motor	250	250	250	⁴ 300	⁴ 300	⁴ 350	⁴ 350
³ Minimum Circuit Ampacity	Unit Only		174	181	188	207	224	243	247
	Power Exhaust	50% Standard Static (1) 1 hp motor	178	186	193	212	229	248	252
		100% Standard Static (2) 1 hp motor	183	191	198	217	233	253	257
		50% High Static (1) 3 hp motor	184	192	199	218	234	254	258
		100% High Static (2) 3 hp motor	195	202	209	229	245	264	268
		50% High Static (1) 5 hp motor	190	198	205	224	241	260	264
		100% High Static (2) 5 hp motor	207	215	221	241	257	276	280
		50% High Static (1) 7.5 hp motor	198	205	212	227	241	256	259
		100% High Static (2) 7.5 hp motor	222	230	236	256	272	291	295

NOTE - All units have a minimum Short Circuit Current Rating (SCCR) of 5000 amps.

¹ Extremes of operating range are plus and minus 10% of line voltage.

² HACR type breaker or fuse.

³ Refer to National or Canadian Electrical Code manual to determine wire, fuse and disconnect size requirements.

⁴ Factory installed circuit breaker not available.

ELECTRICAL DATA

HIGH EFFICIENCY - 35 TON (460V-3Ph)

		Model No.	LCH420H4						
¹ Voltage - 60hz			460V-3Ph						
Compressor 1		Rated Load Amps	14.8						
		Locked Rotor Amps	95						
Compressor 2		Rated Load Amps	14.8						
		Locked Rotor Amps	95						
Compressor 3		Rated Load Amps	14.8						
		Locked Rotor Amps	95						
Compressor 4		Rated Load Amps	14.8						
		Locked Rotor Amps	95						
Outdoor Fan Motors (6)		Full Load Amps	2.4						
		(total)	(14.4)						
Service Outlet 115V GFI (amps)			15						
Indoor Blower Motor		Horsepower	5	7.5	10	15	20	25	30
		Full Load Amps	7.6	11	14	21	27	34	35
² Maximum Overcurrent Protection	Unit Only		100	100	100	110	125	150	150
	Power Exhaust	50% Standard Static (1) 1 hp motor	100	100	100	110	125	150	150
		100% Standard Static (2) 1 hp motor	100	100	110	125	125	150	150
		50% High Static (1) 3 hp motor	100	100	110	125	125	150	150
		100% High Static (2) 3 hp motor	100	100	110	125	125	150	150
		50% High Static (1) 5 hp motor	100	110	110	125	125	150	150
		100% High Static (2) 5 hp motor	110	110	110	125	150	150	175
		50% High Static (1) 7.5 hp motor	110	110	110	125	125	150	175
		100% High Static (2) 7.5 hp motor	125	150	150	125	150	150	175
³ Minimum Circuit Ampacity	Unit Only		87	90	93	102	109	118	125
	Power Exhaust	50% Standard Static (1) 1 hp motor	89	92	95	104	111	120	128
		100% Standard Static (2) 1 hp motor	91	95	98	106	114	123	130
		50% High Static (1) 3 hp motor	91	95	98	106	114	123	130
		100% High Static (2) 3 hp motor	96	100	103	111	119	127	135
		50% High Static (1) 5 hp motor	94	98	101	109	117	125	133
		100% High Static (2) 5 hp motor	102	105	108	117	124	133	140
		50% High Static (1) 7.5 hp motor	98	101	104	113	120	129	136
		100% High Static (2) 7.5 hp motor	109	112	115	124	131	140	147

NOTE - All units have a minimum Short Circuit Current Rating (SCCR) of 5000 amps.

¹ Extremes of operating range are plus and minus 10% of line voltage.

² HACR type breaker or fuse.

³ Refer to National or Canadian Electrical Code manual to determine wire, fuse and disconnect size requirements.

ELECTRICAL DATA

HIGH EFFICIENCY - 35 TON (575V-3Ph)

		Model No.	LCH420H4						
¹ Voltage - 60hz			575V-3Ph						
Compressor 1		Rated Load Amps	12.2						
		Locked Rotor Amps	80						
Compressor 2		Rated Load Amps	12.2						
		Locked Rotor Amps	80						
Compressor 3		Rated Load Amps	12.2						
		Locked Rotor Amps	80						
Compressor 4		Rated Load Amps	12.2						
		Locked Rotor Amps	80						
Outdoor Fan Motors (6)		Full Load Amps	2						
		(total)	(12)						
Service Outlet 115V GFI (amps)			20						
Indoor Blower Motor		Horsepower	5	7.5	10	15	20	25	30
		Full Load Amps	6.1	9	11	17	22	27	32
² Maximum Overcurrent Protection	Unit Only		80	80	80	100	110	110	125
	Power Exhaust	50% Standard Static (1) 1 hp motor	80	80	90	100	110	110	125
		100% Standard Static (2) 1 hp motor	80	90	90	100	110	125	125
		50% High Static (1) 3 hp motor	80	90	90	100	110	125	125
		100% High Static (2) 3 hp motor	90	90	90	100	110	125	125
		50% High Static (1) 5 hp motor	80	90	90	100	110	125	125
		100% High Static (2) 5 hp motor	90	90	100	110	110	125	125
		50% High Static (1) 7.5 hp motor	90	90	90	100	110	125	125
		100% High Static (2) 7.5 hp motor	100	100	100	110	125	125	150
	³ Minimum Circuit Ampacity	Unit Only		71	74	76	84	90	96
Power Exhaust		50% Standard Static (1) 1 hp motor	73	76	78	86	92	98	104
		100% Standard Static (2) 1 hp motor	75	78	80	88	94	100	106
		50% High Static (1) 3 hp motor	75	78	80	87	94	100	106
		100% High Static (2) 3 hp motor	79	82	84	91	98	104	110
		50% High Static (1) 5 hp motor	78	80	82	90	96	102	108
		100% High Static (2) 5 hp motor	84	87	89	96	102	108	114
		50% High Static (1) 7.5 hp motor	80	83	85	93	99	105	111
		100% High Static (2) 7.5 hp motor	89	92	94	102	108	114	120

NOTE - All units have a minimum Short Circuit Current Rating (SCCR) of 5000 amps.

¹ Extremes of operating range are plus and minus 10% of line voltage.

² HACR type breaker or fuse.

³ Refer to National or Canadian Electrical Code manual to determine wire, fuse and disconnect size requirements.

ELECTRICAL DATA

STANDARD EFFICIENCY - 40 TON (208/230V-3Ph)

		Model No.	LCH480S4						
¹ Voltage - 60hz			208/230V-3Ph						
Compressor 1		Rated Load Amps	30.1						
		Locked Rotor Amps	225						
Compressor 2		Rated Load Amps	30.1						
		Locked Rotor Amps	225						
Compressor 3		Rated Load Amps	30.1						
		Locked Rotor Amps	225						
Compressor 4		Rated Load Amps	30.1						
		Locked Rotor Amps	225						
Outdoor Fan Motors (6)		Full Load Amps	3.7						
		(total)	(22.2)						
Service Outlet 115V GFI (amps)			15						
Indoor Blower Motor		Horsepower	5	7.5	10	15	20	25	30
		Full Load Amps	16.7	24.2	30.8	46.2	59.4	74.8	78
² Maximum Overcurrent Protection	Unit Only		175	200	200	225	250	⁴ 300	⁴ 300
	Power Exhaust	50% Standard Static (1) 1 hp motor	200	200	200	250	250	⁴ 300	⁴ 300
		100% Standard Static (2) 1 hp motor	200	200	200	250	250	⁴ 300	⁴ 300
		50% High Static (1) 3 hp motor	200	200	225	250	250	⁴ 300	⁴ 300
		100% High Static (2) 3 hp motor	200	225	225	250	⁴ 300	⁴ 300	⁴ 300
		50% High Static (1) 5 hp motor	200	200	225	250	250	⁴ 300	⁴ 300
		100% High Static (2) 5 hp motor	225	225	225	250	⁴ 300	⁴ 300	⁴ 350
		50% High Static (1) 7.5 hp motor	200	225	225	250	⁴ 300	⁴ 300	⁴ 300
		100% High Static (2) 7.5 hp motor	225	250	250	250	⁴ 300	⁴ 350	⁴ 350
³ Minimum Circuit Ampacity	Unit Only		170	178	184	204	220	239	243
	Power Exhaust	50% Standard Static (1) 1 hp motor	175	182	189	208	225	244	248
		100% Standard Static (2) 1 hp motor	180	187	194	213	230	249	253
		50% High Static (1) 3 hp motor	181	188	195	214	231	250	254
		100% High Static (2) 3 hp motor	191	199	205	225	241	260	264
		50% High Static (1) 5 hp motor	187	194	201	220	237	256	260
		100% High Static (2) 5 hp motor	203	211	218	237	253	273	277
		50% High Static (1) 7.5 hp motor	194	202	208	224	237	252	256
		100% High Static (2) 7.5 hp motor	218	226	233	252	268	288	292

NOTE - All units have a minimum Short Circuit Current Rating (SCCR) of 5000 amps.

¹ Extremes of operating range are plus and minus 10% of line voltage.

² HACR type breaker or fuse.

³ Refer to National or Canadian Electrical Code manual to determine wire, fuse and disconnect size requirements.

⁴ Factory installed circuit breaker not available.

ELECTRICAL DATA

STANDARD EFFICIENCY - 40 TON (460V-3Ph)

Model No.		LCH480S4							
¹ Voltage - 60hz		460V-3Ph							
Compressor 1	Rated Load Amps	16.7							
	Locked Rotor Amps	114							
Compressor 2	Rated Load Amps	16.7							
	Locked Rotor Amps	114							
Compressor 3	Rated Load Amps	16.7							
	Locked Rotor Amps	114							
Compressor 4	Rated Load Amps	16.7							
	Locked Rotor Amps	114							
Outdoor Fan Motors (6)	Full Load Amps	1.9							
	(total)	(11.4)							
Service Outlet 115V GFI (amps)		15							
Indoor Blower Motor	Horsepower	5	7.5	10	15	20	25	30	
	Full Load Amps	7.6	11	14	21	27	34	35	
² Maximum Overcurrent Protection	Unit Only		100	110	110	125	125	150	150
	Power Exhaust	50% Standard Static (1) 1 hp motor	110	110	110	125	125	150	150
		100% Standard Static (2) 1 hp motor	110	110	110	125	125	150	150
		50% High Static (1) 3 hp motor	110	110	110	125	125	150	150
		100% High Static (2) 3 hp motor	110	110	110	125	125	150	150
		50% High Static (1) 5 hp motor	110	110	110	125	125	150	150
		100% High Static (2) 5 hp motor	110	125	125	125	150	150	150
		50% High Static (1) 7.5 hp motor	110	110	125	125	150	150	150
		100% High Static (2) 7.5 hp motor	125	150	150	150	150	175	175
	³ Minimum Circuit Ampacity	Unit Only		92	95	98	106	114	122
Power Exhaust		50% Standard Static (1) 1 hp motor	94	97	100	109	116	125	126
		100% Standard Static (2) 1 hp motor	96	100	103	111	118	127	128
		50% High Static (1) 3 hp motor	96	100	103	111	118	127	128
		100% High Static (2) 3 hp motor	101	105	108	116	123	132	133
		50% High Static (1) 5 hp motor	99	103	106	114	121	130	131
		100% High Static (2) 5 hp motor	107	110	113	121	129	138	139
		50% High Static (1) 7.5 hp motor	103	106	109	117	125	133	135
		100% High Static (2) 7.5 hp motor	114	117	120	128	136	144	146

NOTE - All units have a minimum Short Circuit Current Rating (SCCR) of 5000 amps.

¹ Extremes of operating range are plus and minus 10% of line voltage.

² HACR type breaker or fuse.

³ Refer to National or Canadian Electrical Code manual to determine wire, fuse and disconnect size requirements.

ELECTRICAL DATA

STANDARD EFFICIENCY - 40 TON (575V-3Ph)

		Model No.	LCH480S4						
¹ Voltage - 60hz			575V-3Ph						
Compressor 1		Rated Load Amps	12.2						
		Locked Rotor Amps	80						
Compressor 2		Rated Load Amps	12.2						
		Locked Rotor Amps	80						
Compressor 3		Rated Load Amps	12.2						
		Locked Rotor Amps	80						
Compressor 4		Rated Load Amps	12.2						
		Locked Rotor Amps	80						
Outdoor Fan Motors (6)		Full Load Amps	1.6						
		(total)	(9.6)						
Service Outlet 115V GFI (amps)			20						
Indoor Blower Motor		Horsepower	5	7.5	10	15	20	25	30
		Full Load Amps	6.1	9	11	17	22	27	32
² Maximum Overcurrent Protection		Unit Only	80	80	80	90	100	110	125
	Power Exhaust	50% Standard Static (1) 1 hp motor	80	80	80	90	110	110	125
		100% Standard Static (2) 1 hp motor	80	80	80	100	110	110	125
		50% High Static (1) 3 hp motor	80	80	80	100	110	110	125
		100% High Static (2) 3 hp motor	80	90	90	100	110	125	125
		50% High Static (1) 5 hp motor	80	80	90	100	110	125	125
		100% High Static (2) 5 hp motor	90	90	90	100	110	125	125
		50% High Static (1) 7.5 hp motor	80	90	90	100	110	125	125
		100% High Static (2) 7.5 hp motor	90	100	100	110	125	125	125
³ Minimum Circuit Ampacity		Unit Only	69	72	74	81	87	94	100
	Power Exhaust	50% Standard Static (1) 1 hp motor	71	74	76	83	89	96	102
		100% Standard Static (2) 1 hp motor	73	76	78	85	91	98	104
		50% High Static (1) 3 hp motor	73	76	78	85	91	98	104
		100% High Static (2) 3 hp motor	77	80	82	89	95	101	108
		50% High Static (1) 5 hp motor	75	78	80	87	93	100	106
		100% High Static (2) 5 hp motor	81	84	86	93	100	106	112
		50% High Static (1) 7.5 hp motor	78	81	83	90	96	103	109
		100% High Static (2) 7.5 hp motor	87	90	92	99	105	112	118

NOTE - All units have a minimum Short Circuit Current Rating (SCCR) of 5000 amps.

¹ Extremes of operating range are plus and minus 10% of line voltage.

² HACR type breaker or fuse.

³ Refer to National or Canadian Electrical Code manual to determine wire, fuse and disconnect size requirements.

ELECTRICAL DATA

HIGH EFFICIENCY - 40 TON (208/230V-3Ph)

Model No.		LCH480H4							
¹ Voltage - 60hz		208/230V-3Ph							
Compressor 1	Rated Load Amps	30.1							
	Locked Rotor Amps	225							
Compressor 2	Rated Load Amps	30.1							
	Locked Rotor Amps	225							
Compressor 3	Rated Load Amps	30.1							
	Locked Rotor Amps	225							
Compressor 4	Rated Load Amps	30.1							
	Locked Rotor Amps	225							
Outdoor Fan Motors (6)	Full Load Amps	4.8							
	(total)	(28.8)							
Service Outlet 115V GFI (amps)		15							
Indoor Blower Motor	Horsepower	5	7.5	10	15	20	25	30	
	Full Load Amps	16.7	24.2	30.8	46.2	59.4	74.8	78	
² Maximum Overcurrent Protection	Unit Only		200	200	200	250	250	⁴ 300	⁴ 300
	Power Exhaust	50% Standard Static (1) 1 hp motor	200	200	225	250	250	⁴ 300	⁴ 300
		100% Standard Static (2) 1 hp motor	200	200	225	250	250	⁴ 300	⁴ 300
		50% High Static (1) 3 hp motor	200	200	225	250	250	⁴ 300	⁴ 300
		100% High Static (2) 3 hp motor	225	225	225	250	⁴ 300	⁴ 300	⁴ 300
		50% High Static (1) 5 hp motor	200	225	225	250	⁴ 300	⁴ 300	⁴ 300
		100% High Static (2) 5 hp motor	225	225	250	250	⁴ 300	⁴ 350	⁴ 350
		50% High Static (1) 7.5 hp motor	225	225	225	250	⁴ 300	⁴ 300	⁴ 350
		100% High Static (2) 7.5 hp motor	250	250	250	⁴ 300	⁴ 300	⁴ 350	⁴ 350
³ Minimum Circuit Ampacity	Unit Only		177	184	191	210	227	246	250
	Power Exhaust	50% Standard Static (1) 1 hp motor	181	189	196	215	231	251	255
		100% Standard Static (2) 1 hp motor	186	194	200	220	236	255	259
		50% High Static (1) 3 hp motor	187	195	201	221	237	256	260
		100% High Static (2) 3 hp motor	198	205	212	231	248	267	271
		50% High Static (1) 5 hp motor	193	201	208	227	243	263	267
		100% High Static (2) 5 hp motor	210	218	224	244	260	279	283
		50% High Static (1) 7.5 hp motor	201	208	215	230	244	259	262
		100% High Static (2) 7.5 hp motor	225	233	239	259	275	294	298

NOTE - All units have a minimum Short Circuit Current Rating (SCCR) of 5000 amps.

¹ Extremes of operating range are plus and minus 10% of line voltage.

² HACR type breaker or fuse.

³ Refer to National or Canadian Electrical Code manual to determine wire, fuse and disconnect size requirements.

⁴ Factory installed circuit breaker not available.

ELECTRICAL DATA

HIGH EFFICIENCY - 40 TON (460V-3Ph)

		Model No.	LCH480H4						
¹ Voltage - 60hz			460V-3Ph						
Compressor 1		Rated Load Amps	16.7						
		Locked Rotor Amps	114						
Compressor 2		Rated Load Amps	16.7						
		Locked Rotor Amps	114						
Compressor 3		Rated Load Amps	16.7						
		Locked Rotor Amps	114						
Compressor 4		Rated Load Amps	16.7						
		Locked Rotor Amps	114						
Outdoor Fan Motors (6)		Full Load Amps (total)	2.4 (14.4)						
Service Outlet 115V GFI (amps)			15						
Indoor Blower Motor		Horsepower	5	7.5	10	15	20	25	30
		Full Load Amps	7.6	11	14	21	27	34	35
² Maximum Overcurrent Protection	Unit Only		110	110	110	125	125	150	150
	Power Exhaust	50% Standard Static (1) 1 hp motor	110	110	110	125	125	150	150
		100% Standard Static (2) 1 hp motor	110	110	110	125	125	150	150
		50% High Static (1) 3 hp motor	110	110	110	125	125	150	150
		100% High Static (2) 3 hp motor	110	110	125	125	150	150	150
		50% High Static (1) 5 hp motor	110	110	110	125	150	150	150
		100% High Static (2) 5 hp motor	125	125	125	125	150	150	175
		50% High Static (1) 7.5 hp motor	110	125	125	125	150	150	150
		100% High Static (2) 7.5 hp motor	125	125	125	150	150	175	175
³ Minimum Circuit Ampacity	Unit Only		95	98	101	109	117	125	127
	Power Exhaust	50% Standard Static (1) 1 hp motor	97	100	103	112	119	128	129
		100% Standard Static (2) 1 hp motor	99	103	106	114	121	130	131
		50% High Static (1) 3 hp motor	99	103	106	114	121	130	131
		100% High Static (2) 3 hp motor	104	108	111	119	126	135	136
		50% High Static (1) 5 hp motor	102	106	109	117	124	133	134
		100% High Static (2) 5 hp motor	110	113	116	124	132	141	142
		50% High Static (1) 7.5 hp motor	106	109	112	120	128	136	138
		100% High Static (2) 7.5 hp motor	117	120	123	131	139	147	149

NOTE - All units have a minimum Short Circuit Current Rating (SCCR) of 5000 amps.

¹ Extremes of operating range are plus and minus 10% of line voltage.

² HACR type breaker or fuse.

³ Refer to National or Canadian Electrical Code manual to determine wire, fuse and disconnect size requirements.

ELECTRICAL DATA

HIGH EFFICIENCY - 40 TON (575V-3Ph)

		Model No.	LCH480H4						
¹ Voltage - 60hz			575V-3Ph						
Compressor 1		Rated Load Amps	12.2						
		Locked Rotor Amps	80						
Compressor 2		Rated Load Amps	12.2						
		Locked Rotor Amps	80						
Compressor 3		Rated Load Amps	12.2						
		Locked Rotor Amps	80						
Compressor 4		Rated Load Amps	12.2						
		Locked Rotor Amps	80						
Outdoor Fan Motors (6)		Full Load Amps	2						
		(total)	(12)						
Service Outlet 115V GFI (amps)			20						
Indoor Blower Motor		Horsepower	5	7.5	10	15	20	25	30
		Full Load Amps	6.1	9	11	17	22	27	32
² Maximum Overcurrent Protection	Unit Only		80	80	80	100	110	110	125
	Power Exhaust	50% Standard Static (1) 1 hp motor	80	80	90	100	110	110	125
		100% Standard Static (2) 1 hp motor	80	90	90	100	110	125	125
		50% High Static (1) 3 hp motor	80	90	90	100	110	125	125
		100% High Static (2) 3 hp motor	90	90	90	100	110	125	125
		50% High Static (1) 5 hp motor	80	90	90	100	110	125	125
		100% High Static (2) 5 hp motor	90	90	100	110	110	125	125
		50% High Static (1) 7.5 hp motor	90	90	90	100	110	125	125
		100% High Static (2) 7.5 hp motor	100	100	100	110	125	125	150
³ Minimum Circuit Ampacity	Unit Only		71	74	76	84	90	96	102
	Power Exhaust	50% Standard Static (1) 1 hp motor	73	76	78	86	92	98	104
		100% Standard Static (2) 1 hp motor	75	78	80	88	94	100	106
		50% High Static (1) 3 hp motor	75	78	80	87	94	100	106
		100% High Static (2) 3 hp motor	79	82	84	91	98	104	110
		50% High Static (1) 5 hp motor	78	80	82	90	96	102	108
		100% High Static (2) 5 hp motor	84	87	89	96	102	108	114
		50% High Static (1) 7.5 hp motor	80	83	85	93	99	105	111
		100% High Static (2) 7.5 hp motor	89	92	94	102	108	114	120

NOTE - All units have a minimum Short Circuit Current Rating (SCCR) of 5000 amps.

¹ Extremes of operating range are plus and minus 10% of line voltage.

² HACR type breaker or fuse.

³ Refer to National or Canadian Electrical Code manual to determine wire, fuse and disconnect size requirements.

ELECTRICAL DATA

STANDARD EFFICIENCY - 45 TON (208/230V-3Ph)

		Model No.	LCH540S4						
¹ Voltage - 60hz			208/230V-3Ph						
Compressor 1		Rated Load Amps	33.3						
		Locked Rotor Amps	239						
Compressor 2		Rated Load Amps	33.3						
		Locked Rotor Amps	239						
Compressor 3		Rated Load Amps	33.3						
		Locked Rotor Amps	239						
Compressor 4		Rated Load Amps	33.3						
		Locked Rotor Amps	239						
Outdoor Fan Motors (6)		Full Load Amps	3.7						
		(total)	(22.2)						
Service Outlet 115V GFI (amps)			15						
Indoor Blower Motor		Horsepower	5	7.5	10	15	20	25	30
		Full Load Amps	16.7	24.2	30.8	46.2	59.4	74.8	78
² Maximum Overcurrent Protection	Unit Only		200	200	225	250	250	⁴ 300	⁴ 300
	Power Exhaust	50% Standard Static (1) 1 hp motor	200	225	225	250	250	⁴ 300	⁴ 300
		100% Standard Static (2) 1 hp motor	225	225	225	250	⁴ 300	⁴ 300	⁴ 300
		50% High Static (1) 3 hp motor	225	225	225	250	⁴ 300	⁴ 300	⁴ 300
		100% High Static (2) 3 hp motor	225	225	250	250	⁴ 300	⁴ 300	⁴ 350
		50% High Static (1) 5 hp motor	225	225	225	250	⁴ 300	⁴ 300	⁴ 350
		100% High Static (2) 5 hp motor	225	250	250	⁴ 300	⁴ 300	⁴ 350	⁴ 350
		50% High Static (1) 7.5 hp motor	225	225	250	250	⁴ 300	⁴ 350	⁴ 350
		100% High Static (2) 7.5 hp motor	250	250	250	⁴ 300	⁴ 300	⁴ 350	⁴ 350
³ Minimum Circuit Ampacity	Unit Only		184	191	198	216	233	252	256
	Power Exhaust	50% Standard Static (1) 1 hp motor	188	196	203	221	238	257	261
		100% Standard Static (2) 1 hp motor	193	201	207	226	242	262	266
		50% High Static (1) 3 hp motor	194	202	208	227	243	263	267
		100% High Static (2) 3 hp motor	205	212	219	238	254	273	277
		50% High Static (1) 5 hp motor	200	208	214	233	250	269	273
		100% High Static (2) 5 hp motor	217	225	231	250	266	285	289
		50% High Static (1) 7.5 hp motor	208	215	222	237	251	266	269
		100% High Static (2) 7.5 hp motor	232	240	246	265	281	300	304

NOTE - All units have a minimum Short Circuit Current Rating (SCCR) of 5000 amps.

¹ Extremes of operating range are plus and minus 10% of line voltage.

² HACR type breaker or fuse.

³ Refer to National or Canadian Electrical Code manual to determine wire, fuse and disconnect size requirements.

⁴ Factory installed circuit breaker not available.

ELECTRICAL DATA

STANDARD EFFICIENCY - 45 TON (460V-3Ph)

Model No.		LCH540S4							
¹ Voltage - 60hz		460V-3Ph							
Compressor 1	Rated Load Amps	17.9							
	Locked Rotor Amps	125							
Compressor 2	Rated Load Amps	17.9							
	Locked Rotor Amps	125							
Compressor 3	Rated Load Amps	17.9							
	Locked Rotor Amps	125							
Compressor 4	Rated Load Amps	17.9							
	Locked Rotor Amps	125							
Outdoor Fan Motors (6)	Full Load Amps	1.9							
	(total)	(11.4)							
Service Outlet 115V GFI (amps)		15							
Indoor Blower Motor	Horsepower	5	7.5	10	15	20	25	30	
	Full Load Amps	7.6	11	14	21	27	34	35	
² Maximum Overcurrent Protection	Unit Only		110	110	110	125	125	150	150
	Power Exhaust	50% Standard Static (1) 1 hp motor	110	110	110	125	125	150	150
		100% Standard Static (2) 1 hp motor	110	110	125	125	125	150	150
		50% High Static (1) 3 hp motor	110	110	125	125	125	150	150
		100% High Static (2) 3 hp motor	110	125	125	125	150	150	150
		50% High Static (1) 5 hp motor	110	125	125	125	150	150	150
		100% High Static (2) 5 hp motor	125	125	125	150	150	175	175
		50% High Static (1) 7.5 hp motor	125	125	125	125	150	150	150
		100% High Static (2) 7.5 hp motor	125	125	125	150	150	175	175
	³ Minimum Circuit Ampacity	Unit Only		97	100	103	111	118	127
Power Exhaust		50% Standard Static (1) 1 hp motor	99	103	106	113	121	130	131
		100% Standard Static (2) 1 hp motor	102	105	108	116	123	132	133
		50% High Static (1) 3 hp motor	102	105	108	116	123	132	133
		100% High Static (2) 3 hp motor	106	110	113	121	128	137	138
		50% High Static (1) 5 hp motor	104	108	111	119	126	135	136
		100% High Static (2) 5 hp motor	112	115	118	126	134	142	144
		50% High Static (1) 7.5 hp motor	108	111	114	122	129	138	139
		100% High Static (2) 7.5 hp motor	119	122	125	133	140	149	150

NOTE - All units have a minimum Short Circuit Current Rating (SCCR) of 5000 amps.

¹ Extremes of operating range are plus and minus 10% of line voltage.

² HACR type breaker or fuse.

³ Refer to National or Canadian Electrical Code manual to determine wire, fuse and disconnect size requirements.

ELECTRICAL DATA

STANDARD EFFICIENCY - 45 TON (575V-3Ph)

		Model No.	LCH540S4						
¹ Voltage - 60hz			575V-3Ph						
Compressor 1		Rated Load Amps	12.8						
		Locked Rotor Amps	80						
Compressor 2		Rated Load Amps	12.8						
		Locked Rotor Amps	80						
Compressor 3		Rated Load Amps	12.8						
		Locked Rotor Amps	80						
Compressor 4		Rated Load Amps	12.8						
		Locked Rotor Amps	80						
Outdoor Fan Motors (6)		Full Load Amps	1.6						
		(total)	(9.6)						
Service Outlet 115V GFI (amps)			20						
Indoor Blower Motor		Horsepower	5	7.5	10	15	20	25	30
		Full Load Amps	6.1	9	11	17	22	27	32
² Maximum Overcurrent Protection		Unit Only	80	80	80	100	110	110	125
	Power Exhaust	50% Standard Static (1) 1 hp motor	80	80	90	100	110	110	125
		100% Standard Static (2) 1 hp motor	80	90	90	100	110	125	125
		50% High Static (1) 3 hp motor	80	90	90	100	110	125	125
		100% High Static (2) 3 hp motor	90	90	90	100	110	125	125
		50% High Static (1) 5 hp motor	90	90	90	100	110	125	125
		100% High Static (2) 5 hp motor	90	90	100	110	110	125	125
		50% High Static (1) 7.5 hp motor	90	90	90	100	110	125	125
		100% High Static (2) 7.5 hp motor	100	100	100	110	125	125	150
³ Minimum Circuit Ampacity		Unit Only	72	74	76	84	90	96	102
	Power Exhaust	50% Standard Static (1) 1 hp motor	74	76	78	86	92	98	104
		100% Standard Static (2) 1 hp motor	76	78	80	88	94	100	106
		50% High Static (1) 3 hp motor	75	78	80	87	94	100	106
		100% High Static (2) 3 hp motor	79	82	84	91	98	104	110
		50% High Static (1) 5 hp motor	78	81	83	90	96	102	108
		100% High Static (2) 5 hp motor	84	87	89	96	102	108	114
		50% High Static (1) 7.5 hp motor	81	83	85	93	99	105	111
		100% High Static (2) 7.5 hp motor	90	92	94	102	108	114	120

NOTE - All units have a minimum Short Circuit Current Rating (SCCR) of 5000 amps.

¹ Extremes of operating range are plus and minus 10% of line voltage.

² HACR type breaker or fuse.

³ Refer to National or Canadian Electrical Code manual to determine wire, fuse and disconnect size requirements.

ELECTRICAL DATA

STANDARD EFFICIENCY - 50 TON (208/230V-3Ph)

		Model No.	LCH600S4						
¹ Voltage - 60hz			208/230V-3Ph						
Compressor 1		Rated Load Amps	48.1						
		Locked Rotor Amps	245						
Compressor 2		Rated Load Amps	48.1						
		Locked Rotor Amps	245						
Compressor 3		Rated Load Amps	48.1						
		Locked Rotor Amps	245						
Compressor 4		Rated Load Amps	48.1						
		Locked Rotor Amps	245						
Outdoor Fan Motors (6)		Full Load Amps	4.8						
		(total)	(28.8)						
Service Outlet 115V GFI (amps)			15						
Indoor Blower Motor		Horsepower	5	7.5	10	15	20	25	30
		Full Load Amps	16.7	24.2	30.8	46.2	59.4	74.8	78
² Maximum Overcurrent Protection	Unit Only		⁴ 300	⁴ 300	⁴ 300	⁴ 300	⁴ 350	⁴ 350	⁴ 350
	Power Exhaust	50% Standard Static (1) 1 hp motor	⁴ 300	⁴ 300	⁴ 300	⁴ 300	⁴ 350	⁴ 350	⁴ 400
		100% Standard Static (2) 1 hp motor	⁴ 300	⁴ 300	⁴ 300	⁴ 300	⁴ 350	⁴ 400	⁴ 400
		50% High Static (1) 3 hp motor	⁴ 300	⁴ 300	⁴ 300	⁴ 300	⁴ 350	⁴ 400	⁴ 400
		100% High Static (2) 3 hp motor	⁴ 300	⁴ 300	⁴ 300	⁴ 350	⁴ 350	⁴ 400	⁴ 400
		50% High Static (1) 5 hp motor	⁴ 300	⁴ 300	⁴ 300	⁴ 300	⁴ 350	⁴ 400	⁴ 400
		100% High Static (2) 5 hp motor	⁴ 300	⁴ 300	⁴ 350	⁴ 350	⁴ 350	⁴ 400	⁴ 400
		50% High Static (1) 7.5 hp motor	⁴ 300	⁴ 300	⁴ 300	⁴ 350	⁴ 350	⁴ 400	⁴ 400
		100% High Static (2) 7.5 hp motor	⁴ 350	⁴ 350	⁴ 350	⁴ 350	⁴ 400	⁴ 400	⁴ 400
³ Minimum Circuit Ampacity	Unit Only		253	260	267	282	298	317	321
	Power Exhaust	50% Standard Static (1) 1 hp motor	258	265	272	287	303	322	326
		100% Standard Static (2) 1 hp motor	262	270	276	292	308	327	331
		50% High Static (1) 3 hp motor	263	271	277	293	309	328	332
		100% High Static (2) 3 hp motor	274	281	288	303	319	339	343
		50% High Static (1) 5 hp motor	269	277	284	299	315	334	338
		100% High Static (2) 5 hp motor	286	294	300	316	332	351	355
		50% High Static (1) 7.5 hp motor	277	284	291	306	320	335	338
		100% High Static (2) 7.5 hp motor	301	309	315	331	347	366	370

NOTE - All units have a minimum Short Circuit Current Rating (SCCR) of 5000 amps.

¹ Extremes of operating range are plus and minus 10% of line voltage.

² HACR type breaker or fuse.

³ Refer to National or Canadian Electrical Code manual to determine wire, fuse and disconnect size requirements.

⁴ Factory installed circuit breaker not available.

ELECTRICAL DATA

STANDARD EFFICIENCY - 50 TON (460V-3Ph)

		Model No.	LCH600S4						
¹ Voltage - 60hz			460V-3Ph						
Compressor 1		Rated Load Amps	18.6						
		Locked Rotor Amps	125						
Compressor 2		Rated Load Amps	18.6						
		Locked Rotor Amps	125						
Compressor 3		Rated Load Amps	18.6						
		Locked Rotor Amps	125						
Compressor 4		Rated Load Amps	18.6						
		Locked Rotor Amps	125						
Outdoor Fan Motors (6)		Full Load Amps	2.4						
		(total)	(14.4)						
Service Outlet 115V GFI (amps)			15						
Indoor Blower Motor		Horsepower	5	7.5	10	15	20	25	30
		Full Load Amps	7.6	11	14	21	27	34	35
² Maximum Overcurrent Protection	Unit Only		110	110	125	125	150	150	150
	Power Exhaust	50% Standard Static (1) 1 hp motor	110	125	125	125	150	150	150
		100% Standard Static (2) 1 hp motor	125	125	125	125	150	150	150
		50% High Static (1) 3 hp motor	125	125	125	125	150	150	150
		100% High Static (2) 3 hp motor	125	125	125	150	150	175	175
		50% High Static (1) 5 hp motor	125	125	125	125	150	150	175
		100% High Static (2) 5 hp motor	125	125	125	150	150	175	175
		50% High Static (1) 7.5 hp motor	125	125	125	150	150	175	175
		100% High Static (2) 7.5 hp motor	125	150	150	150	150	175	175
³ Minimum Circuit Ampacity	Unit Only		103	106	109	117	124	133	134
	Power Exhaust	50% Standard Static (1) 1 hp motor	105	109	112	119	127	135	137
		100% Standard Static (2) 1 hp motor	108	111	114	122	129	138	139
		50% High Static (1) 3 hp motor	108	111	114	122	129	138	139
		100% High Static (2) 3 hp motor	112	116	119	126	134	143	144
		50% High Static (1) 5 hp motor	110	114	117	124	132	141	142
		100% High Static (2) 5 hp motor	118	121	124	132	139	148	149
		50% High Static (1) 7.5 hp motor	114	117	120	128	135	144	145
		100% High Static (2) 7.5 hp motor	125	128	131	139	146	155	156

NOTE - All units have a minimum Short Circuit Current Rating (SCCR) of 5000 amps.

¹ Extremes of operating range are plus and minus 10% of line voltage.

² HACR type breaker or fuse.

³ Refer to National or Canadian Electrical Code manual to determine wire, fuse and disconnect size requirements.

ELECTRICAL DATA

STANDARD EFFICIENCY - 50 TON (575V-3Ph)

		Model No.	LCH600S4						
¹ Voltage - 60hz			575V-3Ph						
Compressor 1		Rated Load Amps	14.8						
		Locked Rotor Amps	100						
Compressor 2		Rated Load Amps	14.8						
		Locked Rotor Amps	100						
Compressor 3		Rated Load Amps	14.8						
		Locked Rotor Amps	100						
Compressor 4		Rated Load Amps	14.8						
		Locked Rotor Amps	100						
Outdoor Fan Motors (6)		Full Load Amps	2						
		(total)	(12)						
Service Outlet 115V GFI (amps)			20						
Indoor Blower Motor		Horsepower	5	7.5	10	15	20	25	30
		Full Load Amps	6.1	9	11	17	22	27	32
² Maximum Overcurrent Protection	Unit Only		90	90	100	110	110	125	125
	Power Exhaust	50% Standard Static (1) 1 hp motor	90	100	100	110	110	125	125
		100% Standard Static (2) 1 hp motor	100	100	100	110	125	125	125
		50% High Static (1) 3 hp motor	100	100	100	110	125	125	125
		100% High Static (2) 3 hp motor	100	100	100	110	125	125	150
		50% High Static (1) 5 hp motor	100	100	100	110	125	125	150
		100% High Static (2) 5 hp motor	100	110	110	110	125	125	150
		50% High Static (1) 7.5 hp motor	100	100	110	110	125	125	150
		100% High Static (2) 7.5 hp motor	110	110	110	125	125	150	150
³ Minimum Circuit Ampacity	Unit Only		82	85	87	94	100	106	113
	Power Exhaust	50% Standard Static (1) 1 hp motor	84	87	89	96	102	108	115
		100% Standard Static (2) 1 hp motor	86	89	91	98	104	110	117
		50% High Static (1) 3 hp motor	86	89	91	98	104	110	117
		100% High Static (2) 3 hp motor	90	93	95	102	108	114	120
		50% High Static (1) 5 hp motor	89	91	93	100	106	113	119
		100% High Static (2) 5 hp motor	95	98	100	106	112	119	125
		50% High Static (1) 7.5 hp motor	91	94	96	103	109	115	122
		100% High Static (2) 7.5 hp motor	100	103	105	112	118	124	131

NOTE - All units have a minimum Short Circuit Current Rating (SCCR) of 5000 amps.

¹ Extremes of operating range are plus and minus 10% of line voltage.

² HACR type breaker or fuse.

³ Refer to National or Canadian Electrical Code manual to determine wire, fuse and disconnect size requirements.

ELECTRICAL DATA

OPTIONAL ACCESSORIES

208/230V - 3 Ph

Optional Power Exhaust	Static Type	Standard 50%	Standard 100%	High 50%	High 100%	High 50%	High 100%	High 50%	High 100%
	Motor hp		1	1	3	3	5	5	7.5
Number of Motors		1	2	1	2	1	2	1	2
Full load amps total		4.8	9.6	10.6	21.2	16.7	33.4	24.2	48.4
Locked rotor amps total		23	46	66	132	105	210	152	304
Optional Energy Recovery Wheel (ERW)	(No.) hp	(1) 1/4							
	Full load amps	2.3							

460V - 3 Ph

Optional Power Exhaust	Static Type	Standard 50%	Standard 100%	High 50%	High 100%	High 50%	High 100%	High 50%	High 100%
	Motor hp		1	1	3	3	5	5	7.5
Number of Motors		1	2	1	2	1	2	1	2
Full load amps total		2.4	4.8	4.8	9.6	7.6	15.2	11.0	22.0
Locked rotor amps total		11.5	23	26.8	53.6	45.6	91.2	66.0	132.0
Optional Energy Recovery Wheel (ERW)	(No.) hp	(1) 1/4							
	Full load amps	1.2							

575V - 3 Ph

Optional Power Exhaust	Static Type	Standard 50%	Standard 100%	High 50%	High 100%	High 50%	High 100%	High 50%	High 100%
	Motor hp		1	1	3	3	5	5	7.5
Number of Motors		1	2	1	2	1	2	1	2
Full load amps total		2	4	3.9	7.8	6.1	12.2	9	18
Locked rotor amps total		8.9	17.8	23.4	46.8	36.6	73.2	54	108
Optional Energy Recovery Wheel (ERW)	(No.) hp	(1) 1/4							
	Full load amps	1.0							

ELECTRIC HEAT ELECTRICAL DATA

Electric Heat Size (kW)	208/230V-3 phase			460V-3 phase			575V-3 phase		
	Rated Amps	Minimum Circuit Ampacity	Maximum Overcurrent Protection (amps)	Rated Amps	Minimum Circuit Ampacity	Maximum Overcurrent Protection (amps)	Rated Amps	Minimum Circuit Ampacity	Maximum Overcurrent Protection (amps)
30	72.2	91	100	36.1	46	50	28.9	37	40
45	108.3	136	150	54.1	68	70	43.3	55	60
60	144.3	145	150	72.2	73	80	57.7	58	60
75	180.4	181	200	90.2	91	100	72.2	73	80
90	216.5	217	225	108.3	109	110	86.6	87	90
105	---	---	---	126.3	127	150	101.0	101	110
120	---	---	---	144.3	145	150	115.5	116	125
135	---	---	---	162.4	163	175	129.9	130	150
150	---	---	---	180.4	181	200	144.3	145	150
165	---	---	---	198.5	199	200	158.8	159	175
180	---	---	---	216.5	217	225	173.2	174	175

NOTE - All units have a minimum Short Circuit Current Rating (SCCR) of 5000 amps.

ELECTRIC HEAT MATCHES

35 ton units - 30-45-60-75-90 kW (all voltages)

35 ton units - 105-120 kW (460V & 575V only)

40 ton units - 30-45-60-75-90 kW (all voltages)

40 ton units - 105-120-135-150 kW (460V & 575V only)

45 ton units - 45-60-75-90 kW (all voltages)

45 ton units - 105-120-135-150-165 kW (460V & 575V only)

50 ton units - 45-60-75-90 kW (all voltages)

50 ton units - 105-120-135-150-165-180 kW (460V & 575V only)

ELECTRIC HEAT CAPACITIES

Volts Input	30 kW			45 kW			60 kW			75 kW			90 kW			105 kW		
	kW Input	Btuh Output	No. of Steps	kW Input	Btuh Output	No. of Steps	kW Input	Btuh Output	No. of Steps	kW Input	Btuh Output	No. of Steps	kW Input	Btuh Output	No. of Steps	kW Input	Btuh Output	No. of Steps
208	22.5	76,800	1	33.8	115,300	2	45.0	153,600	2	56.3	192,100	3	67.6	230,700	3	---	---	---
220	25.2	86,000	1	37.8	129,000	2	50.4	172,000	2	63.0	215,000	3	75.6	258,000	3	---	---	---
230	27.5	93,900	1	41.3	141,000	2	55.1	188,000	2	68.9	235,100	3	82.7	282,200	3	---	---	---
240	30.0	102,400	1	45.0	153,600	2	60.0	204,800	2	75.0	255,900	3	90.0	307,100	3	---	---	---
440	25.2	86,000	1	37.8	129,000	2	50.4	172,000	2	63.0	215,000	3	75.6	258,000	3	88.2	301,000	4
460	27.5	93,900	1	41.3	141,000	2	55.1	188,000	2	68.9	235,100	3	82.7	282,200	3	96.4	329,000	4
480	30.0	102,400	1	45.0	153,600	2	60.0	204,800	2	75.0	255,900	3	90.0	307,100	3	105.0	358,300	4
550	25.2	86,000	1	37.8	129,000	2	50.4	172,000	2	63.0	215,000	3	75.6	258,000	3	88.2	301,000	4
575	27.5	93,900	1	41.3	141,000	2	55.1	188,000	2	68.9	235,100	3	82.7	282,200	3	96.4	329,000	4
600	30.0	102,400	1	45.0	153,600	2	60.0	204,800	2	75.0	255,900	3	90.0	307,100	3	105.0	358,300	4

ELECTRIC HEAT CAPACITIES

Volts Input	120 kW			135 kW			150 kW			165 kW			180 kW		
	kW Input	Btuh Output	No. of Steps	kW Input	Btuh Output	No. of Steps	kW Input	Btuh Output	No. of Steps	kW Input	Btuh Output	No. of Steps	kW Input	Btuh Output	No. of Steps
440	100.8	344,000	4	113.4	386,900	4	126.0	430,000	4	138.6	473,000	4	151.2	516,000	4
460	110.2	376,100	4	124.0	423,100	4	137.7	469,900	4	151.5	517,000	4	165.2	563,700	4
480	120.0	409,500	4	135.0	460,700	4	150.0	511,900	4	165.0	563,100	4	180.0	614,200	4
550	100.8	344,000	4	113.4	386,900	4	126.0	430,000	4	138.6	473,000	4	151.2	516,000	4
575	110.2	376,100	4	124.0	423,100	4	137.7	469,900	4	151.5	517,000	4	165.2	563,700	4
600	120.0	409,500	4	135.0	460,700	4	150.0	511,900	4	165.0	563,100	4	180.0	614,200	4

INSTALLATION/SERVICE CLEARANCES

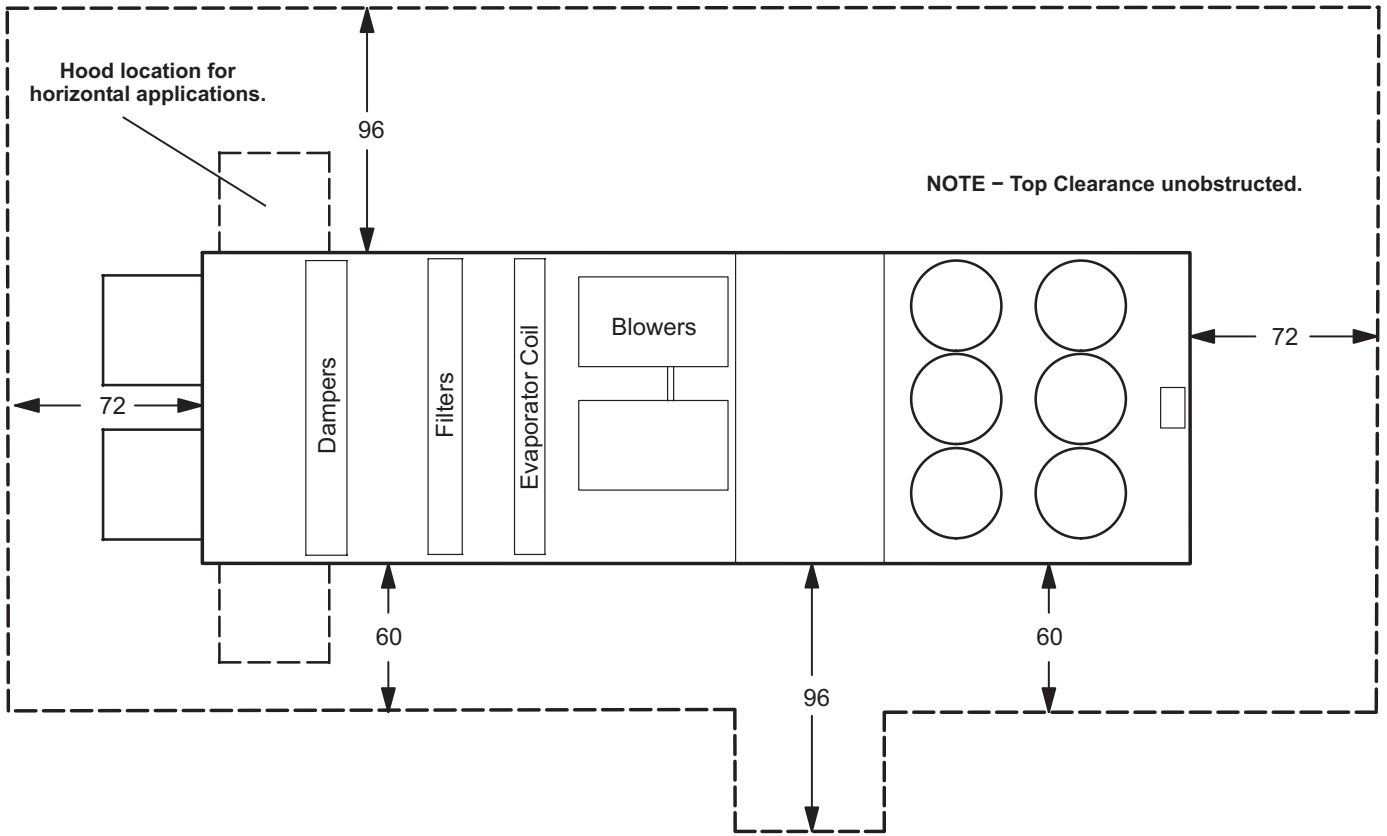

Vertical Airflow Applications - Service clearances can be shared by multiple units.

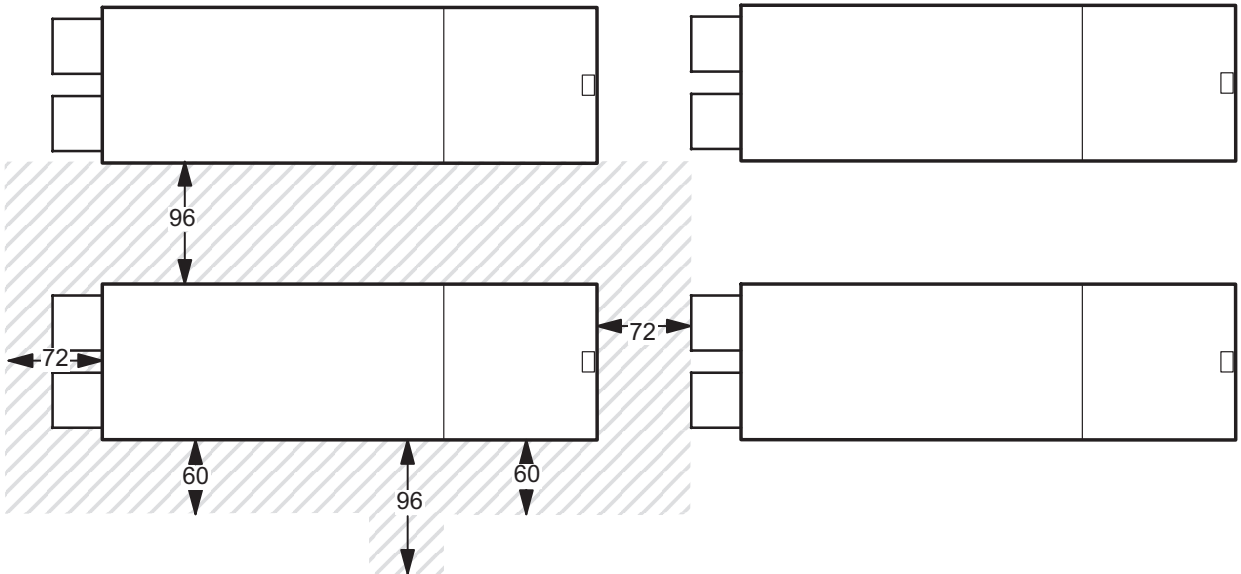

Horizontal Airflow Applications - Service clearances can be shared by multiple units.

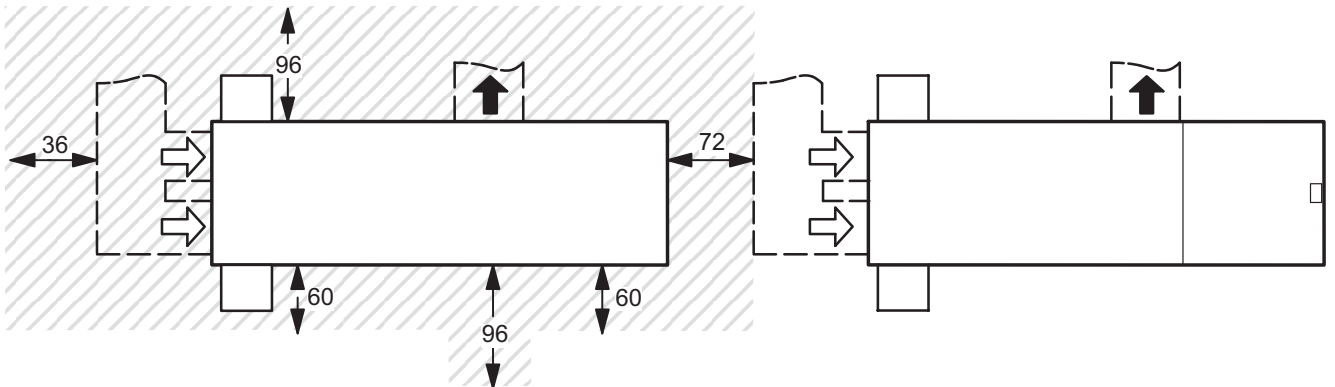

DIMENSIONS - UNIT - VERTICAL AIRFLOW

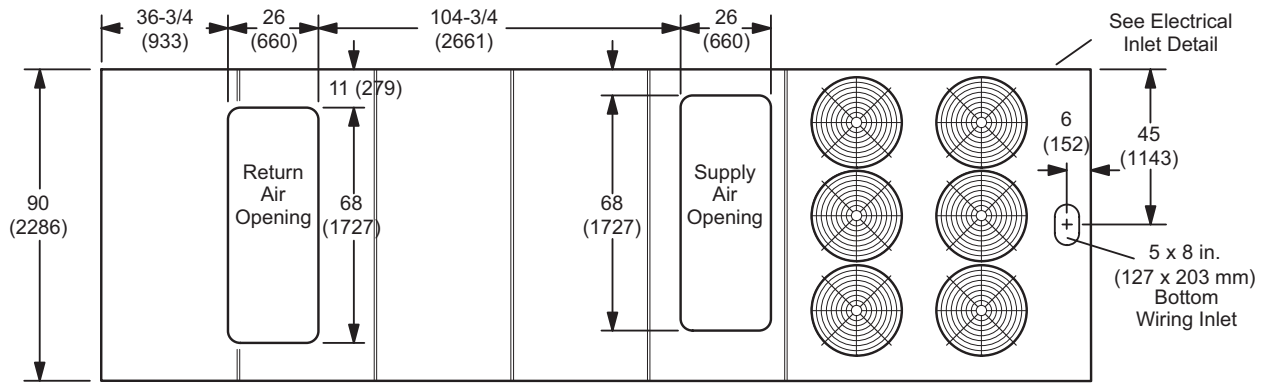

TOP VIEW - Base Section

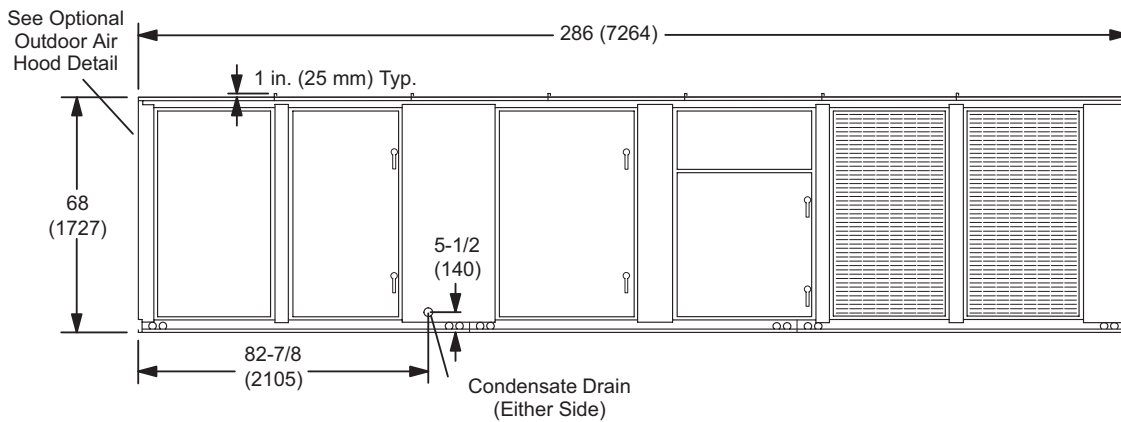

SIDE VIEW

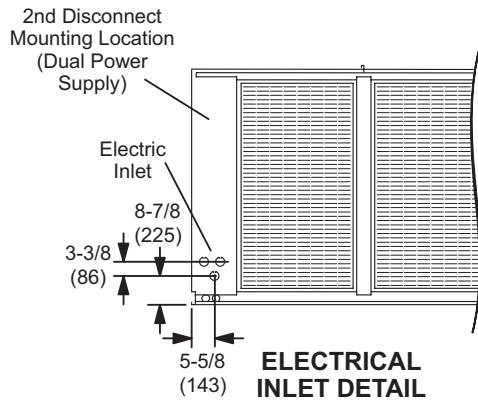

ELECTRICAL INLET DETAIL

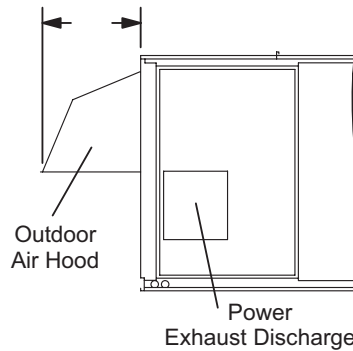

OPTIONAL OUTDOOR AIR HOOD DETAIL

DIMENSIONS - UNIT - HORIZONTAL AIRFLOW

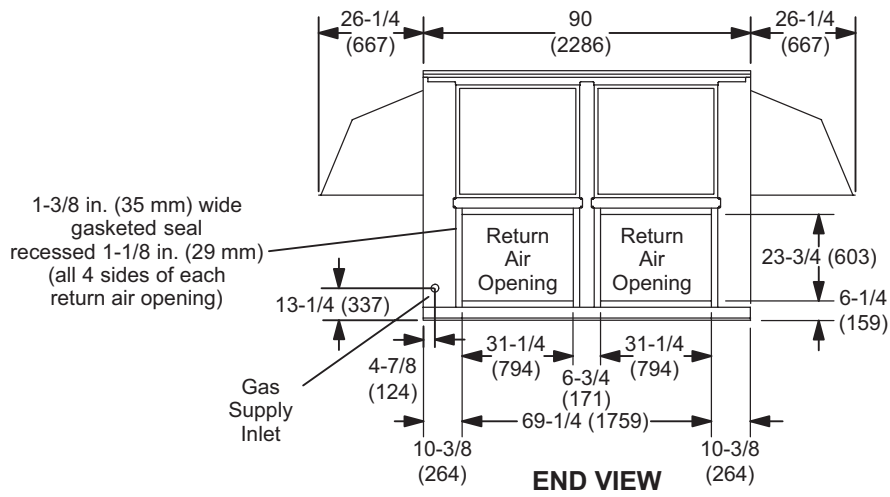
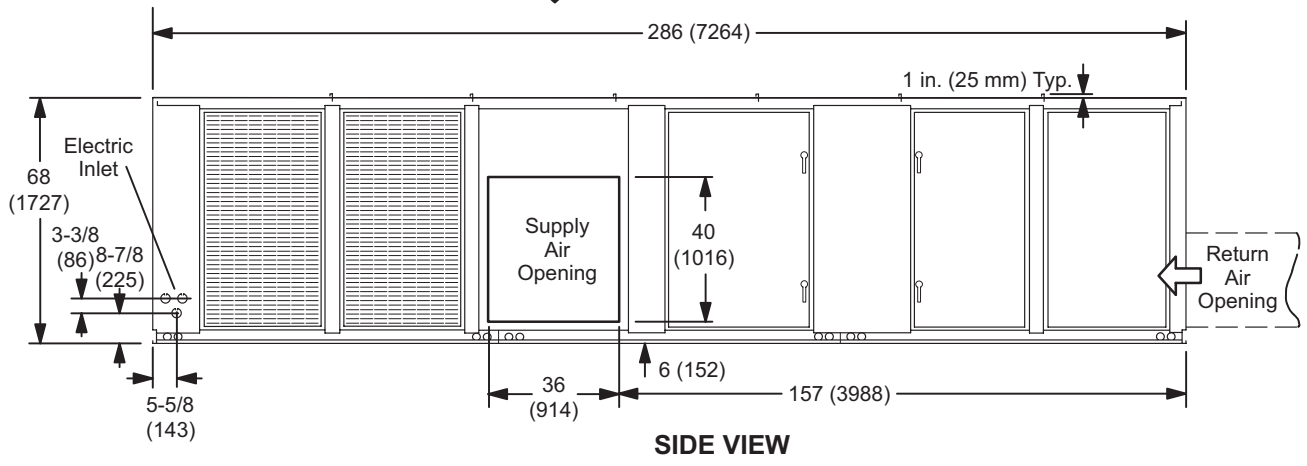
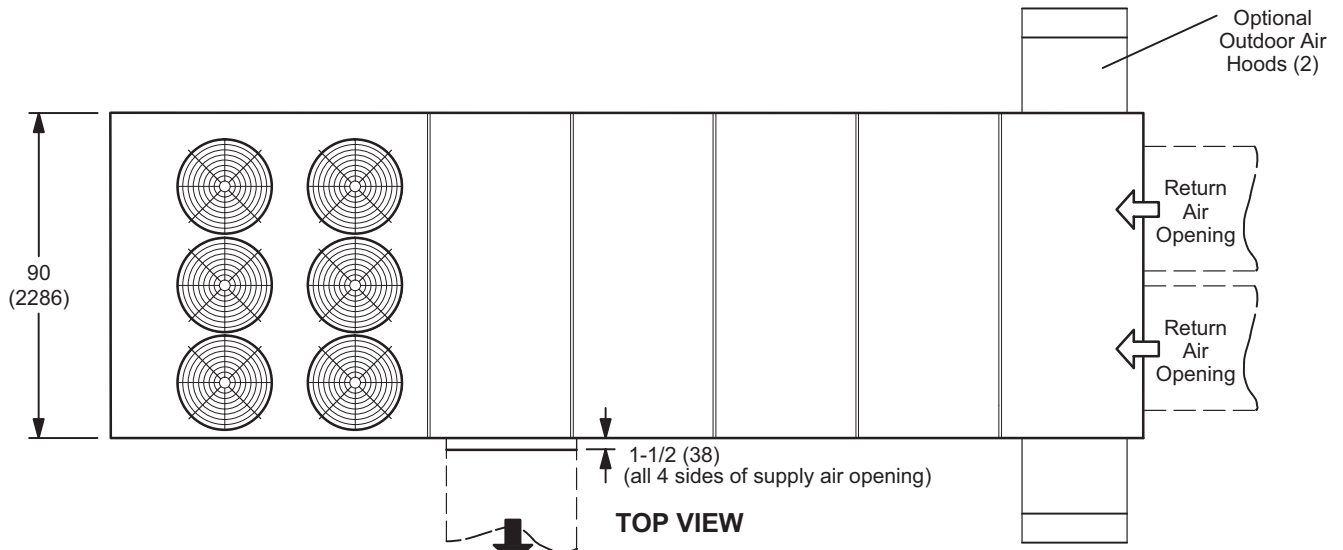

ROOF CURB

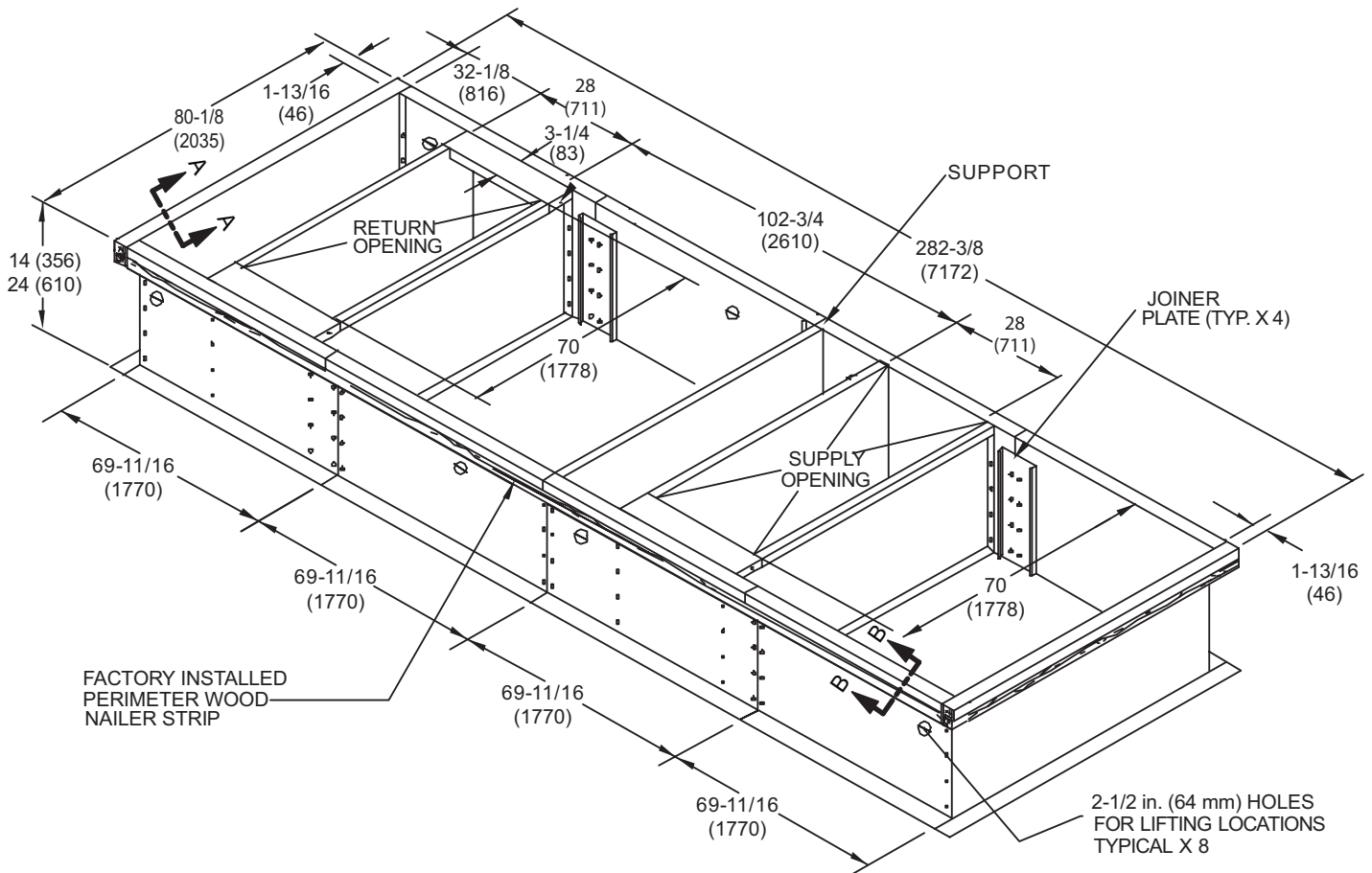

ROOF CURB SECTION A-A

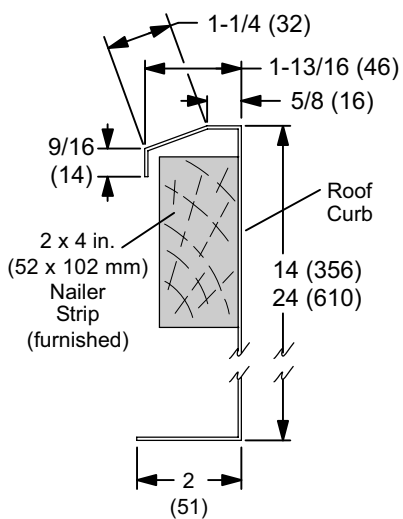

**SIDE SECTION B-B
With Unit Base Rail
and Pan**

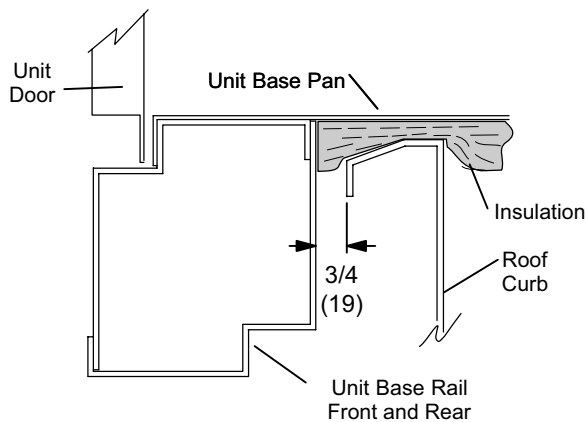

**END SECTION A-A
With Unit Base Rail
and Pan**

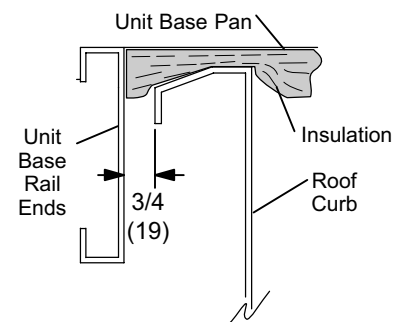

WEIGHT DATA

UNIT WEIGHTS

Model Number	1 Operating Weight - Base Unit		Maximum Unit Rigging Weight	
	lbs.	kg	lbs.	kg
LCH420S4	6100	2767	8045	3649
LCH420H4	6500	2948	8495	3853
LCH480S4	6100	2767	8045	3649
LCH480H4	6550	2971	8495	3853
LCH540S4	6500	2948	8445	3831
LCH600S4	6550	2971	8495	3853

¹ For total weight add base unit weight, indoor blower motor weight and weight of all accessories.

INDOOR BLOWER WEIGHTS

MSAV/Variable Air Volume Blower Motors - hp
weights include variable frequency drive and bypass

	5	7.5	10	15	20	25		30	
						208/230V & 460V	575V	208/230V & 460V	575V
lbs.	90	157	171	232	256	318	346	360	390
kg	41	71	78	105	116	144	157	163	177

OPTIONAL ACCESSORY WEIGHTS - lbs. (kg)

Power Exhaust					
High Static			Standard Static		
50%	100%	Variable Frequency Drive (VFD)	50%	100%	
One Centrifugal Blower	Two Centrifugal Blowers		One Propeller-Type Fan	Two Propeller-Type Fans	
300 (136)	500 (227)	50 (23)	60 (27)	120 (54)	
Barometric Relief Dampers	Disconnect or Circuit Breaker	Economizer	Electric Heat	Energy Recovery Wheel	Humiditrol®
50 (23)	30 (14)	188 (85)	190 (86) maximum	420 (191)	150 (68)
Outdoor Air Dampers	Powered GFI Service Outlet	Roof Curb 14 in.	Roof Curb 24 in.	Service Valves	
140 (64)	30 (14)	370 (168)	625 (283)	25 (11)	

POINT LOADING

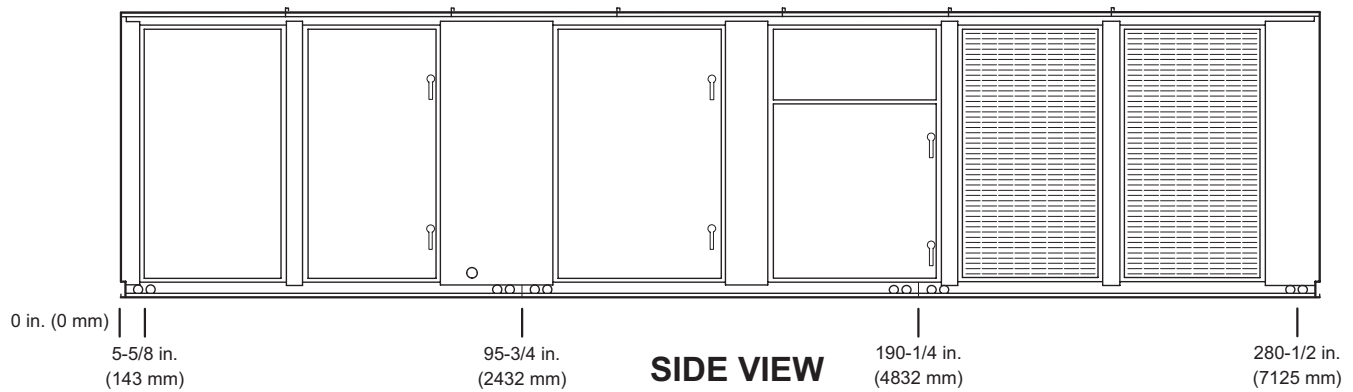
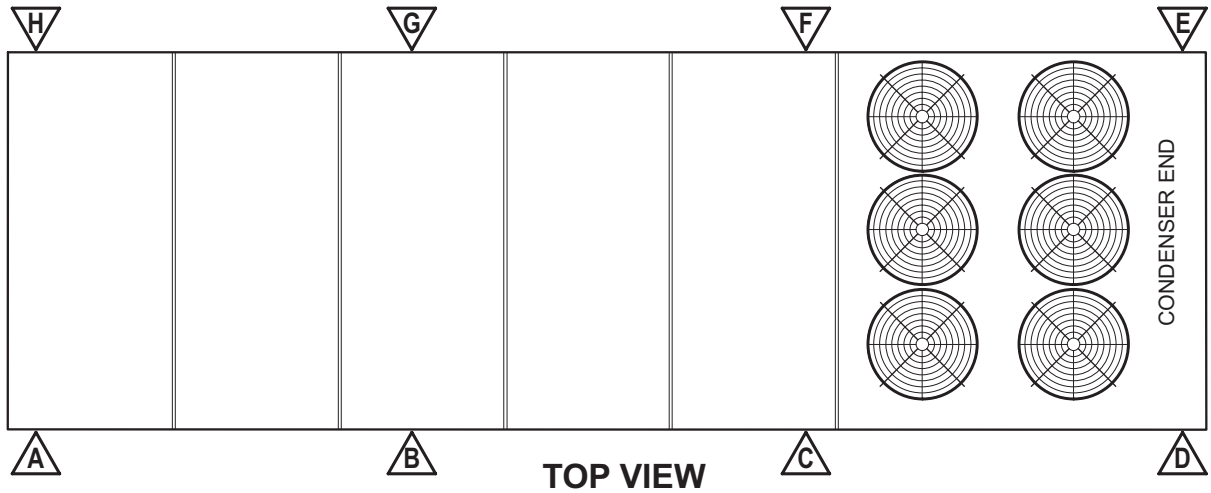

PERCENTAGES OF TOTAL UNIT WEIGHT

To calculate point loads for a specific model, multiply percentages by unit operating weight.

Unit Configuration	A	B	C	D	E	F	G	H
No Power Exhaust or ERW	6%	10%	15%	15%	18%	18%	12%	6%
With Power Exhaust	9%	11%	13%	13%	16%	16%	13%	9%
With Power Exhaust and ERW	10%	12%	12%	12%	15%	15%	14%	10%

REVISIONS

Sections	Description of Change
Optional Conventional Temperature Control Systems	Removed obsolete thermostat models.



Visit us at www.Lennox.com

For the latest technical information, www.LennoxCommercial.com

Contact us at 1-800-4-LENNOX

NOTE - Due to Lennox' ongoing commitment to quality, Specifications, Ratings and Dimensions subject to change without notice and without incurring liability. Improper installation, adjustment, alteration, service or maintenance can cause property damage or personal injury. Installation and service must be performed by a qualified installer and servicing agency.

©2023 Lennox Industries, Inc.