

**⚠ WARNING**

Improper installation, adjustment, alteration, service, or maintenance can cause property damage, personal injury, or loss of life. Installation and service must be performed by a licensed professional HVAC installer or equivalent, service agency, or the gas supplier.

**Table of Contents**

Dimensions . . . . .	2
Parts Arrangement . . . . .	3
Shipping and Packing List . . . . .	4
General . . . . .	4
Requirements . . . . .	4
Unit Support . . . . .	5
Duct Connection . . . . .	5
Rigging Unit for Lifting . . . . .	6
Horizontal Air Discharge . . . . .	6
Condensate Drains . . . . .	6
Connect Gas Piping (Gas Units) . . . . .	8
Pressure Test Gas Piping (Gas Units) . . . . .	9
High Altitude Derate . . . . .	9
Electrical Connections . . . . .	9
Blower Operation and Adjustments . . . . .	11
Cooling Start-Up . . . . .	37
Gas Heat Start-Up (Gas Units) . . . . .	46
Heating Operation and Adjustments . . . . .	47
Electric Heat Start-Up (KC Units) . . . . .	47
Hot Gas Reheat Start-Up and Operation . . . . .	48
Service . . . . .	50

# INSTALLATION INSTRUCTIONS

- KGB/KCB024**     2-Ton
- KGB/KCB030**     2-1/2-Ton
- KGB/KCB036**     3-Ton
- KGB/KCB048**     4-Ton
- KGB/KCB060**     5-Ton
- KGB/KCB074**     6-Ton

**GAS AND COOLING PACKAGED UNITS**

507348-11  
 6/2023  
 Supersedes 507348-10

**⚠ WARNING**

To prevent serious injury or death:

- 1-Lock-out / tag-out before performing maintenance.
- 2-If system power is required (e.g., smoke detector maintenance), disable power to blower, remove fan belt where applicable, and ensure all controllers and thermostats are set to the "OFF" position before performing maintenance.
- 3-Always keep hands, hair, clothing, jewelry, tools, etc., away from moving parts.

**RETAIN THESE INSTRUCTIONS FOR FUTURE REFERENCE**

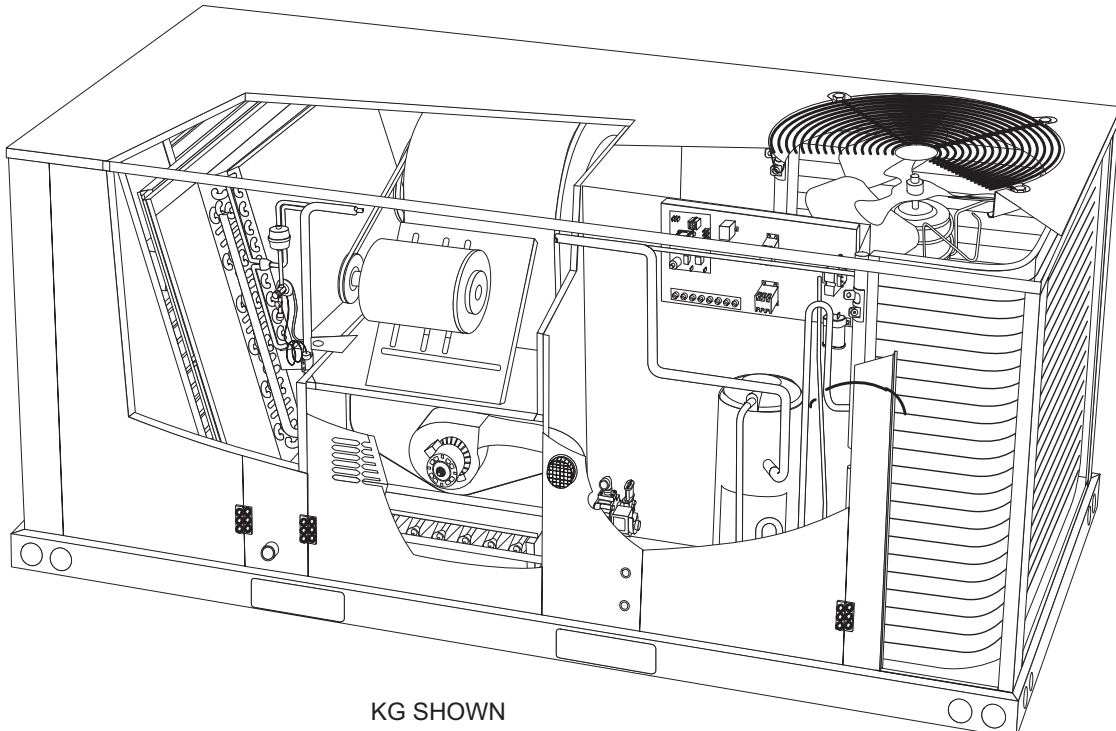

KG SHOWN

**KG / KC 024, 030, 036, 048, 060, 074 DIMENSIONS in. - Gas heat section shown**

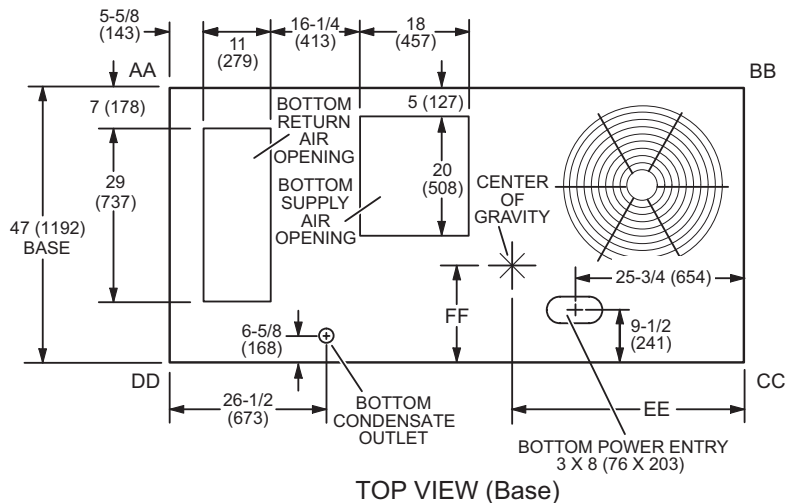

TOP VIEW (Base)

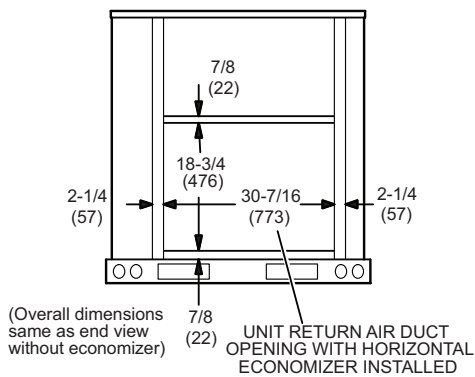

END VIEW

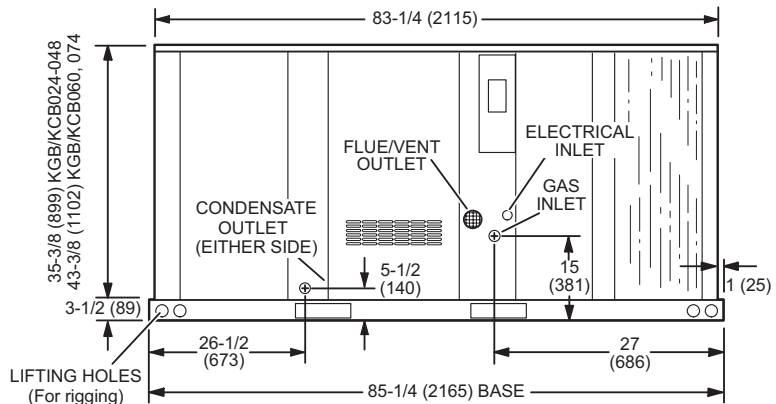

SIDE VIEW

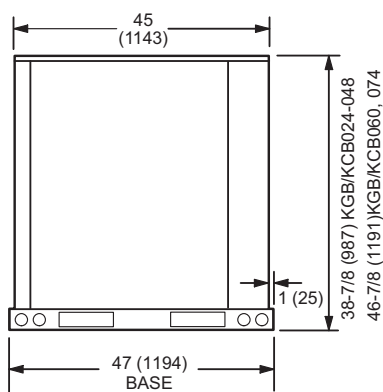

END VIEW

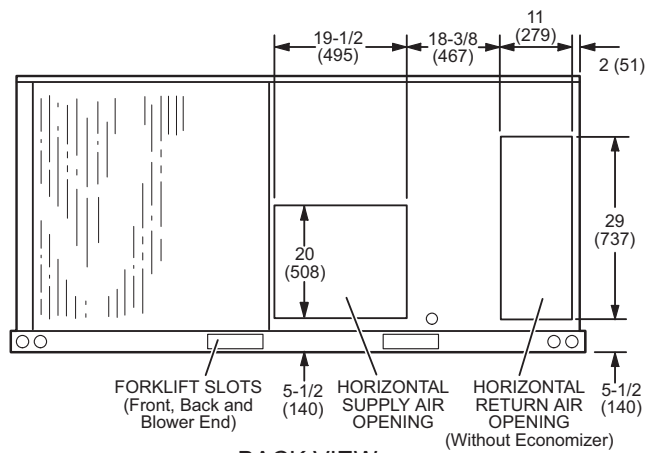

BACK VIEW

**CAUTION**

As with any mechanical equipment, contact with sharp sheet metal edges can result in personal injury. Take care while handling this equipment and wear gloves and protective clothing.

**KG 024, 030, 036, 048, 060, 074 PARTS ARRANGEMENT**

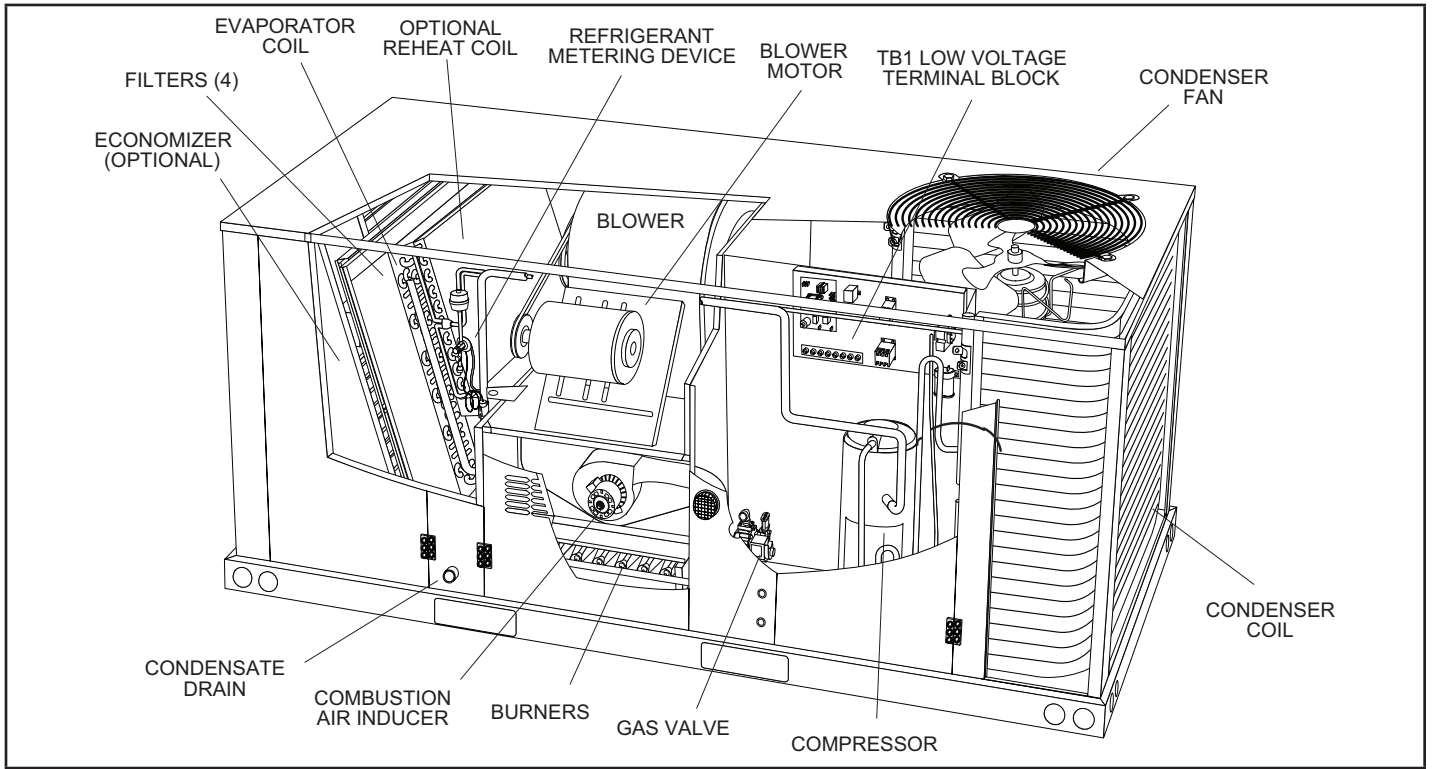

**KC 024, 030, 036, 048, 060, 074 PARTS ARRANGEMENT**

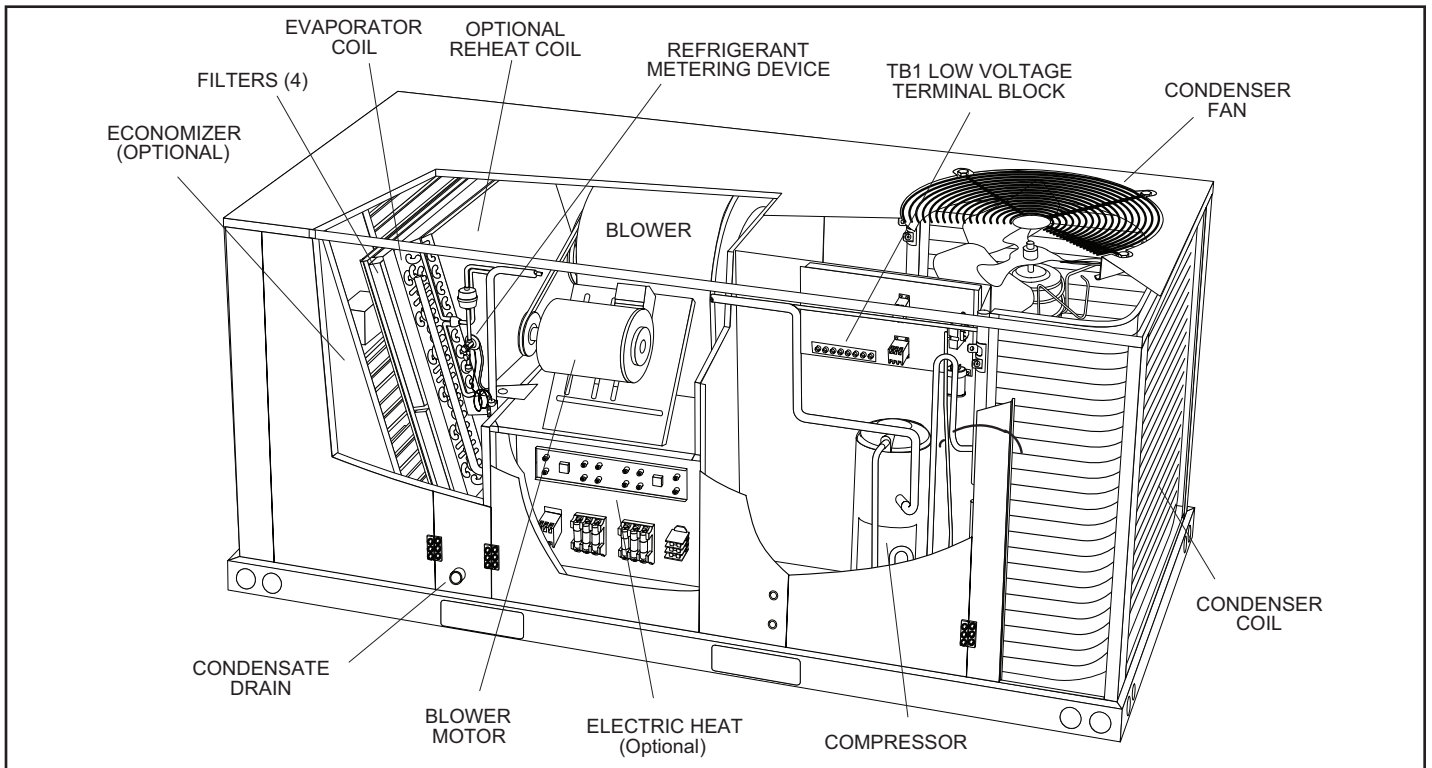

## Shipping and Packing List

### Package 1 of 1 contains:

- 1 - Assembled unit

Check unit for shipping damage. Receiving party should contact last carrier immediately if shipping damage is found.

## General

These instructions are intended as a general guide and do not supersede local codes in any way. Authorities having jurisdiction should be consulted before installation.

The KG units are available in three heating inputs. The KC cooling packaged rooftop unit is the same basic design as the KG unit except for the heating section. Optional electric heat is available for KC units. KG and KC units have identical refrigerant circuits with respective 2, 2-1/2, 3, 4, 5 and 6 ton cooling capacities.

Units are equipped with a factory-installed lightweight, all-aluminum condenser coil. Units are available with an optional, factory-installed fin/tube condenser coil.

Standard efficiency units equipped with fin/tube outdoor coils are available with an optional hot gas reheat coil which provides a dehumidifying mode of operation. Refer to Reheat Operation section.

Availability of units and options varies by brand.

## Requirements

See FIGURE 1 for unit clearances.

## NOTICE

### Roof Damage!

This system contains both refrigerant and oil. Some rubber roofing material may absorb oil, causing the rubber to swell. Bubbles in the rubber roofing material can cause leaks. Protect the roof surface to avoid exposure to refrigerant and oil during service and installation. Failure to follow this notice could result in damage to roof surface.

## WARNING

Electric shock hazard and danger of explosion. Can cause injury, death or product or property damage. Turn off gas and electrical power to unit before performing any maintenance or servicing operations on the unit. Follow lighting instructions attached to unit when putting unit back into operation and after service or maintenance.



## IMPORTANT

The Clean Air Act of 1990 bans the intentional venting of refrigerant (CFC's and HFC's) as of July 1, 1992. Approved methods of recovery, recycling, or reclaiming must be followed. Fines and/or incarceration may be levied for non compliance.

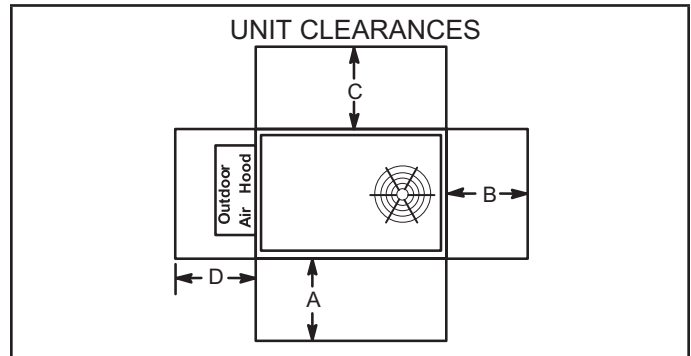

FIGURE 1

Unit Clearance	A in.(mm)	B in.(mm)	C in.(mm)	D in.(mm)	Top Clearance
Service Clearance	48 (1219)	36 (914)	36 (914)	36 (914)	Unobstructed
Clearance to Combustibles	36 (914)	1 (25)	1 (25)	1 (25)	Unobstructed
Minimum Operation Clearance	36 (914)	36 (914)	36 (914)	36 (914)	Unobstructed

NOTE - Entire perimeter of unit base requires support when elevated above mounting surface.

<sup>1</sup>Service Clearance - Required for removal of serviceable parts

Clearance to Combustibles - Required clearance to combustible material (gas units).

Minimum Operation Clearance - Required clearance for proper unit operation.

Use of this unit as a construction heater or air conditioner is not recommended during any phase of construction. Very low return air temperatures, harmful vapors and operation of the unit with clogged or misplaced filters will damage the unit.

If this unit has been used for heating or cooling of buildings or structures under construction, the following conditions must be met or the warranty will be void:

- A room thermostat must control the unit. The use of fixed jumpers that will provide continuous heating or cooling is not allowed.
- A pre-filter must be installed at the entry to the return air duct.
- The return air duct must be provided and sealed to the unit.
- Return air temperature range between 55°F (13°C) and 80°F (27°C) must be maintained.
- Air filters must be replaced and pre-filters must be removed upon construction completion.
- The input rate and temperature rise must be set per the unit rating plate.

- The heat exchanger, components, duct system, air filters, and evaporator coil must be thoroughly cleaned following final construction clean-up.
- The unit operations conditions (including airflow, cooling operation, ignition, input rate, temperature rise, and venting) must be verified according to these installation instructions.

### Unit Support

In downflow discharge installations, install the unit on a non-combustible surface only. Unit may be installed on combustible surfaces when used in horizontal discharge applications or in downflow discharge applications when installed on a T1CURB roof mounting frame.

**NOTE** - Securely fasten roof frame to roof per local codes.

### CAUTION

To reduce the likelihood of supply / return air bypass and promote a proper seal with the RTU, duct work / duct drops / diffuser assemblies must be supported independently to the building structure.

#### A-Downflow Discharge Application

##### Roof Mounting with T1CURB

- 1 - The T1CURB roof mounting frame must be installed, flashed, and sealed in accordance with the instructions provided with the frame.
- 2 - The T1CURB roof mounting frame should be square and level to 1/16-inch per linear foot (5mm per linear meter) in any direction.
- 3 - Duct must be attached to the roof mounting frame and not to the unit; supply and return plenums must be installed before setting the unit.

##### Installer's Roof Mounting Frame

Many types of roof frames can be used to install the unit depending upon different roof structures. Items to keep in mind when using the building frame or supports are:

- 1 - The base is fully enclosed and insulated, so an enclosed frame is not required.
- 2 - The frames or supports must be constructed with non-combustible materials and should be square and level to the 1/16-inch per linear foot (5mm per linear meter) in any direction.
- 3 - Frame or supports must be high enough to prevent any form of moisture from entering unit. Recommended minimum frame height is 14-inches (356mm).
- 4 - Dust must be attached to the roof mounting frame and not to the unit. Supply and return plenums must be installed before setting the unit.
- 5 - Units require support along all four sides of unit base. Supports must be constructed of steel or suitably treated wood materials.

**NOTE** - When installing a unit on a combustible surface for downflow discharge applications, a T1CURB roof mounting frame is required.

#### B-Horizontal Discharge Applications

- 1 - Units which are equipped with an optional economizer and installed in horizontal airflow applications must use a horizontal conversion kit.
- 2 - Specified installation clearances must be maintained when installing unit. Refer to FIGURE 1.
- 3 - Top of support slab should be approximately 4-inches (102mm) above the finished grade and located so no run-off water from higher ground can collect around the unit.
- 4 - Units require support along all four sides of unit base. Supports must be constructed of steel or suitably treated wood materials.

### Duct Connection

All exterior ducts, joints and openings in roof or building walls must be insulated and weather-proofed with flashing and sealing compounds in accordance with applicable codes. Any duct passing through an unconditioned space must be insulated.

### CAUTION

In downflow applications, do not drill or punch holes in base of unit. Leaking in roof may occur if unit base is punctured.



## Rigging Unit for Lifting

Rig unit for lifting by attaching four cables to holes in unit base rail. See FIGURE 2.

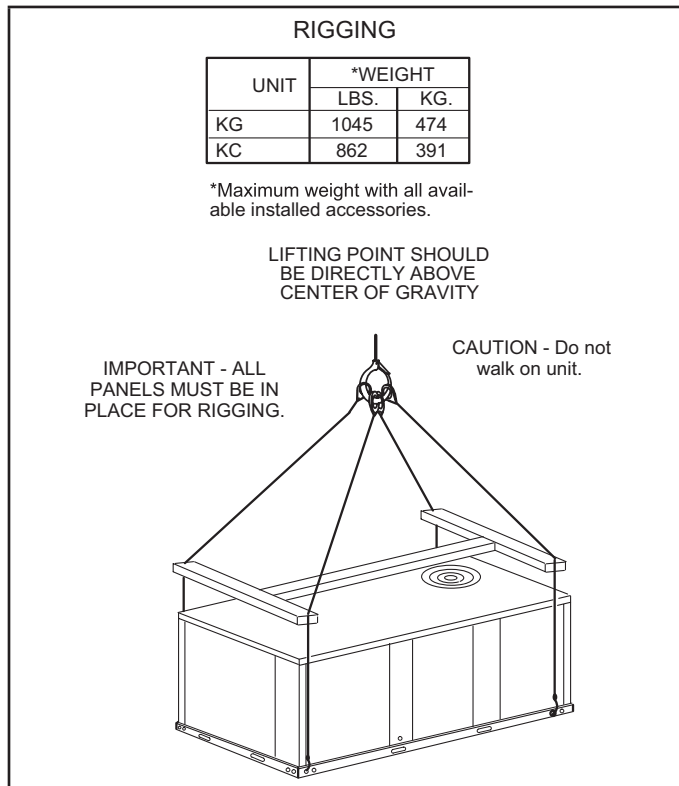

**FIGURE 2**

- 1 - Detach wooden base protection before rigging.
- 2 - Remove all six base protection brackets before setting unit.
- 3 - Connect rigging to the unit base using both holes in each corner.
- 4 - All panels must be in place for rigging.
- 5 - Place field-provided H-style pick in place just above top edge unit. Frame must be of adequate strength and length. (H-style pick prevents damage to unit).

## Horizontal Air Discharge

Unit is shipped with panels covering the horizontal supply and return air openings. Remove horizontal covers and place over downflow openings for horizontal air discharge. See FIGURE 3. Secure in place with sheet metal screws. Seal the full perimeter of the covers with aluminum tape.

### Units Equipped with an Optional Economizer

- 1 - Remove the horizontal supply air cover and position over the downflow supply air opening. Secure with sheet metal screws.
- 2 - Leave the horizontal return air cover in place.

- 3 - Locate the separately ordered horizontal air discharge kit. Place the kit panel over the downflow return air opening.
- 4 - Remove and retain the barometric relief dampers and lower hood.
- 5 - Install return air duct beneath outdoor air intake. See FIGURE 4. Install barometric relief damper in lower hood and install a ductwork as shown in FIGURE 4.

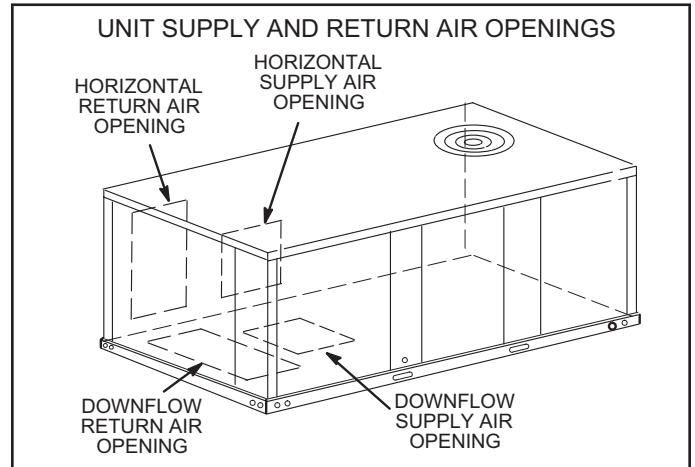

**FIGURE 3**

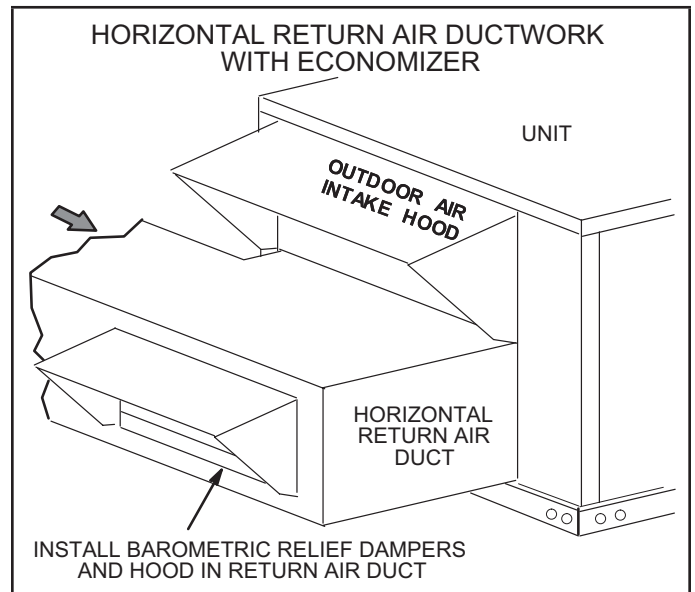

**FIGURE 4**

## Condensate Drains

Make drain connection to the 1-inch N.P.T. drain coupling provided on unit.

**NOTE** - The drain pan is made with a glass reinforced engineered plastic capable of withstanding typical joint torque but can be damaged with excessive force. Tighten pipe nipple hand tight and turn on additional quarter turn.

A trap must be installed between drain connection and an open vent for proper condensate removal. See FIGURE 5 or FIGURE 6. It is sometimes acceptable to drain condensate onto the roof or grade; however, a tee should be fitted to the trap to direct condensate downward. The condensate line must be vented. Check local codes concerning condensate disposal. Refer to page 1 and page 2 for condensate drain location.

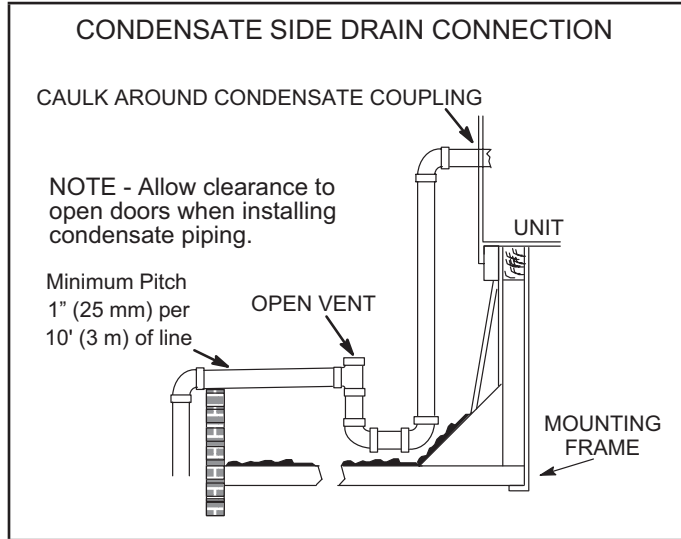

FIGURE 5

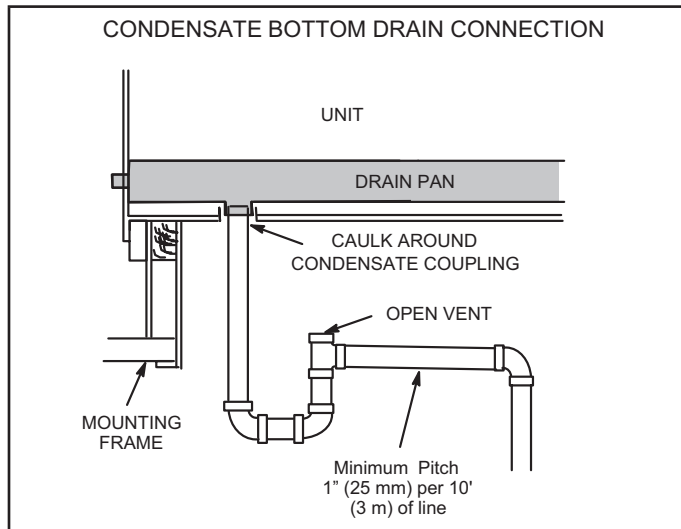

FIGURE 6

Units are shipped with the drain coupling facing the front of the unit. Condensate can be drained from the back or bottom of the unit with the following modifications. The unit can be installed in either downflow or horizontal air discharge regardless of condensate drain location.

**Rear Drain Connection**

- 1 - Remove the condensate drain mullion. See FIGURE 7. Remove the two panels on each side of the mullion.

If the unit has hinged panels, two hinge screws must be removed in addition to the mullion screws. See FIGURE 8.

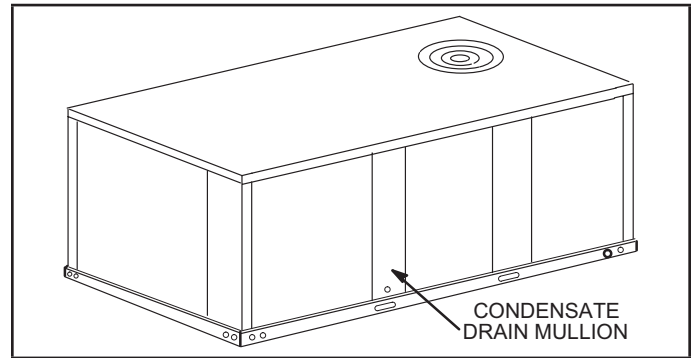

FIGURE 7

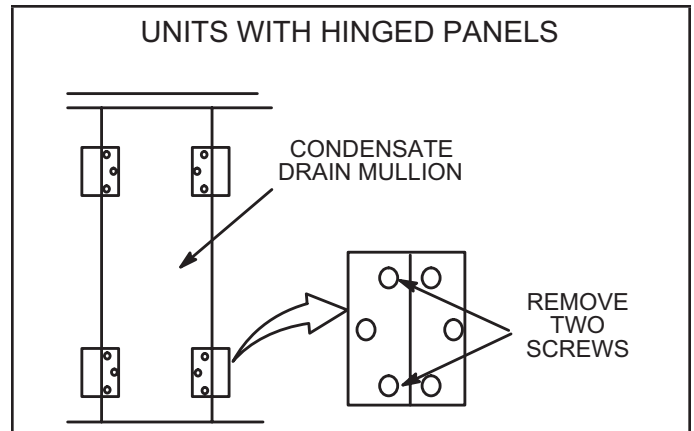

FIGURE 8

- 2 - Lift the front edge of the drain pan and slide pan out of unit. See FIGURE 9.

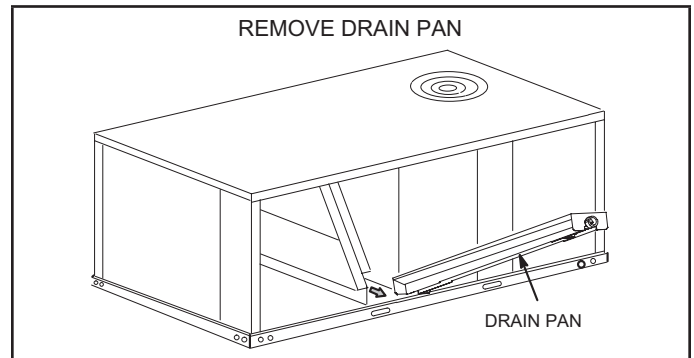
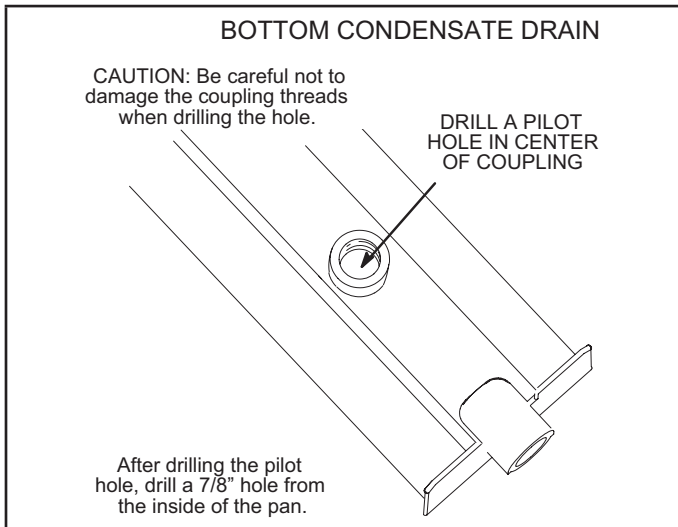

FIGURE 9

- 3 - Make sure the cap over the unit bottom drain hole is secure.
- 4 - Rotate the drain pan until the downward slope is toward the back of the unit. Slide the drain pan back into the unit. Be careful not to dislodge the cap over the bottom drain hole.
- 5 - From the back side of the unit, pull the drain pan coupling through the rear condensate opening.
- 6 - Replace the condensate drain mullion.

### Bottom Drain Connection

- 1 - Remove the condensate drain mullion. See FIGURE 7.
- 2 - Lift the front edge of the drain pan and slide pan out of unit. See FIGURE 9.
- 3 - Turn the drain pan upside down and drill a pilot hole through the bottom of the drain pan in the center of the coupling. See FIGURE 10.



**FIGURE 10**

- 4 - From the inside of the pan, use a Vari-Bit® bit to enlarge the hole to 7/8-inch. Do not damage coupling threads.
- 5 - Remove the cap over the unit bottom drain hole.
- 6 - Slide the drain pan back into the unit.
- 7 - From the back side of the unit, pull the drain pan coupling through the rear condensate opening.
- 8 - From the front side of the unit, move the drain pan until the bottom coupling settles into the unit bottom drain opening. Once in place, check to make sure the coupling is still positioned through the rear condensate drain hole.
- 9 - Use a field-provided 1-inch plug to seal side drain connection.
- 10 - Replace the condensate drain mullion.

### Connect Gas Piping (Gas Units)

Before connecting field-provided piping, check with gas company or authorities having jurisdiction for local code requirements. When installing gas supply piping, length of run from gas meter must be considered in determining pipe size for 0.5-inch w.c. (12kPa) maximum pressure drop. Do not use supply pipe smaller than unit gas connection. Operating pressures at the unit gas connection must be as shown in TABLE 1.

**TABLE 1  
OPERATING PRESSURE AT GAS CONNECTION -  
IN. W.C.**

	Natural Gas		LP / Propane Gas	
	Min.	Max.	Min.	Max.
<b>024-074</b>	4.5	10.5	10.8	13.5

When making piping connections, a drip leg should be installed on vertical pipe runs to serve as a trap for sediment or condensate. A 1/8-inch N.P.T. plugged tap is located on gas valve for test gauge connection. Refer to Heating Start-Up section for tap location. Install a ground joint union between the gas control manifold and the main manual shut-off valve. See FIGURE 11 for gas supply piping entering outside the unit. FIGURE 12 shows complete bottom gas entry piping.

Compounds used on threaded joints of gas piping shall be resistant to the action of liquefied petroleum gases.

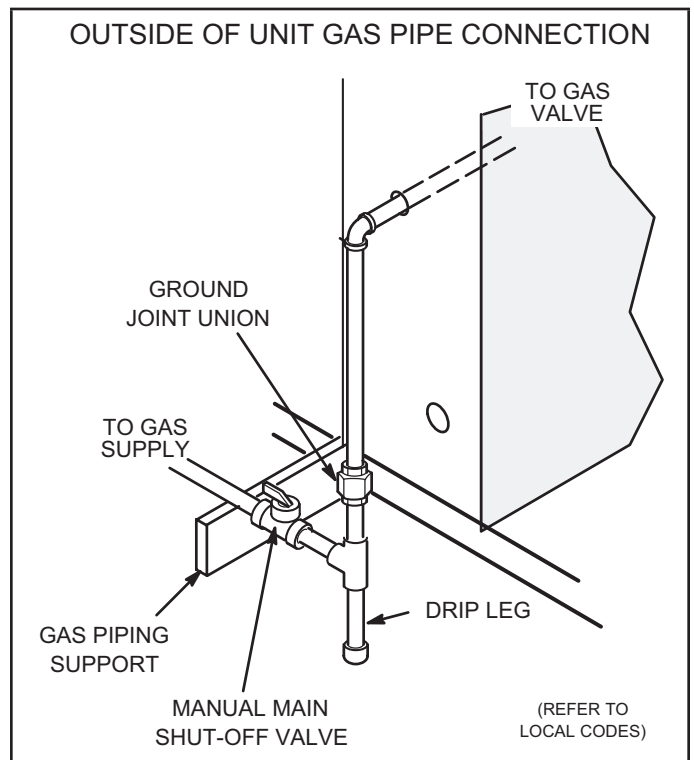

**FIGURE 11**



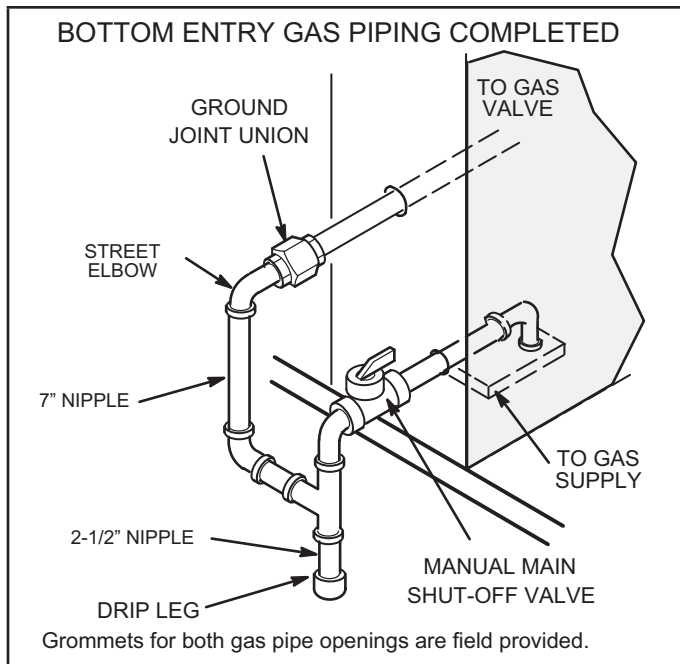

**FIGURE 12**

**Pressure Test Gas Piping (Gas Units)**

When pressure testing gas lines, the gas valve must be disconnected and isolated. Gas valves can be damaged if subjected to more than 0.5-psig (3.48kPa). See FIGURE 13.

**NOTE** - Codes may require that manual main shut-off valve and union (furnished by installer) be installed in gas line external to unit. Union must be of the ground joint type.

After all connections have been made, check all piping connections for gas leaks. Also check existing unit gas connections up to the gas valve; loosening may occur during installation. Use a leak detection solution or other preferred means. Do not use matches, candles, or other sources of ignition to check for gas leaks.

**⚠ CAUTION**

Some soaps used for leak detection are corrosive to certain metals. Carefully rinse piping thoroughly after leak test has been completed. Do not use matches, candles, flame, or other sources of ignition to check for gas leaks.

**⚠ WARNING**

**Danger of explosion. Can cause injury or product or property damage. Do not use matches, candles, flame or other sources of ignition to check for leaks.**

**NOTE** - In case emergency shut down is required, turn off the main manual shut-off valve and disconnect main power to unit. These devices should be properly labeled by the installer.

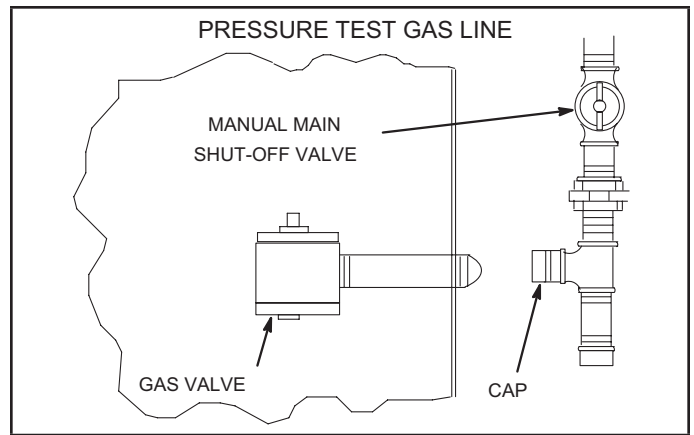

**FIGURE 13**

**High Altitude Derate**

Locate the high altitude conversion sticker in the unit literature bag. Fill out the conversion sticker and affix next to the unit nameplate.

Refer to TABLE 2 for high altitude adjustments.

**TABLE 2  
HIGH ALTITUDE DERATE**

Altitude Ft.*	Gas Manifold Pressure
2000-4500	See Unit Nameplate
4500 and Above	Delete 2% / 1000 Ft. Above Sea Level

\*Units installed at 0-2000 feet do not need to be modified.

**NOTE** - This is the only permissible derate for these units.

**Electrical Connections**

**POWER SUPPLY**

Do not apply power or close disconnect switch until installation is complete. Refer to start-up directions. Refer closely to unit wiring diagram.

Refer to unit nameplate for minimum circuit ampacity and maximum fuse size.

- Units are factory-wired for 230, 460, 575 volt supply. **For 208V supply**, remove the insulated terminal cover from the 208V terminal on the control transformer. Move the wire from the transformer 240V terminal to the 208V terminal. Place the insulated terminal cover on the unused 240V terminal.
- Route power through the bottom power entry area. On KG units, connect power wiring to L1, L2, and L3 on top of K1 in control area above compressor. On KC units, route power wiring to TBV2. Secure power wiring with factory-installed wire ties provided in control box. See unit wiring diagram.

## CONTROL WIRING

### A-Thermostat Location

Room thermostat mounts vertically on a standard 2-inch x 4-inch handy box or on any non-conductive flat surface.

Locate thermostat approximately 5-feet (1524mm) above the floor in an area with good air circulation at average temperature. Avoid locating the room thermostat where it might be affected by:

- Drafts or dead spots behind doors and in corners
- Hot or cold air from ducts
- Radiant heat from sun or appliances
- Concealed pipes and chimneys

### B-Control Wiring

- 1 - Route thermostat cable or wires from sub-base to control area above compressor (refer to unit dimensions to locate bottom and side power entry).

**IMPORTANT** - Unless field thermostat wires are rated for maximum voltage, they must be routed away from line voltage wiring. Use wire ties located near the lower left corner of the controls hat section to secure thermostat cable.

Use 18 AWG wire for all applications using remotely installed thermostats.

- 2 - Install thermostat assembly in accordance with instructions provided with thermostat.
- 3 - Connect thermostat wiring to TB1 terminal board on the lower side of the controls hat section. Wire as shown in figure 14 for electro-mechanical and electronic thermostats. If using other temperature control devices or energy management systems,

see instructions and wiring diagram provided by manufacturer.

**IMPORTANT** - Terminal connections at the wall plate or sub-base must be made securely. Loose control wire connections may allow unit to operate but not with proper response to room demand.

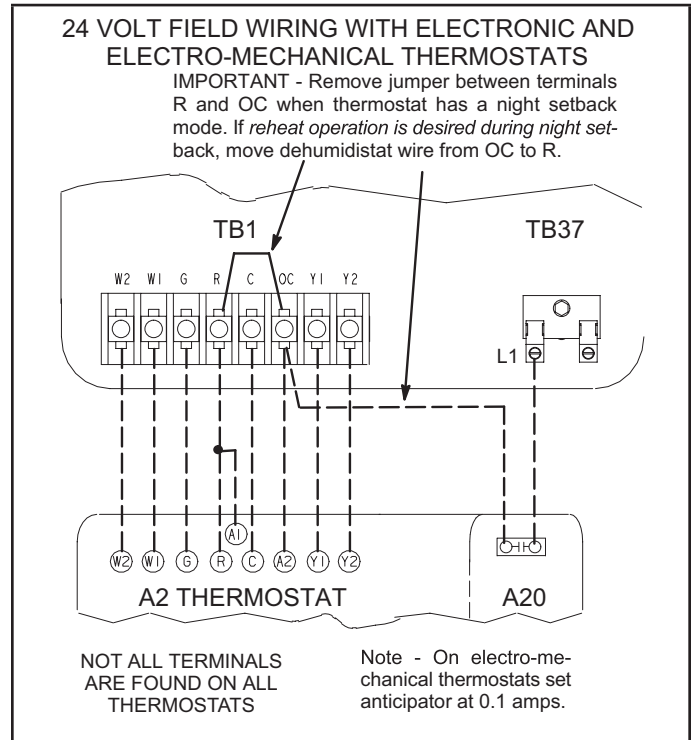

FIGURE 14

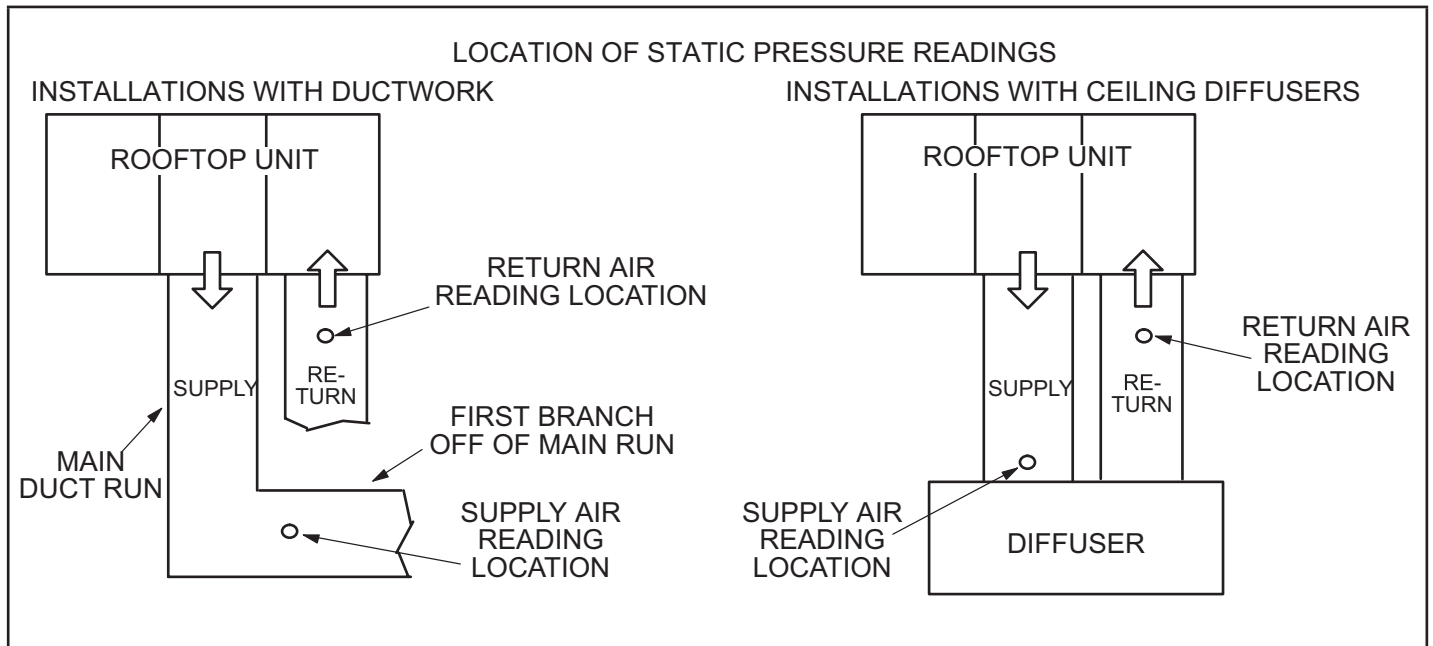

FIGURE 15

## C-Hot Gas Reheat Units Only

Units require a dehumidify demand to initiate operation. A 24V input a TB37-L1 is required to energize reheat. A standalone dehumidistat (A20) and/or a room thermostat/energy management system with humidity sensing may be used. Refer to device manual for setup details.

- 1 - When a dehumidistat is used, route wires from the A20 dehumidistat switch to the control box. Install dehumidistat assembly in accordance with instructions provided with the dehumidistat.
- 2 - Connect dehumidistat and/or thermostat wiring to TB1 and TB37 as shown in FIGURE 14.

**IMPORTANT** - Remove jumper between terminals R (24V) and OC when thermostat has a night setback mode. If reheat operation is desired during night setback, move dehumidistat wire from OC to R.

**NOTE** - When initially setting up some thermostats, a dehumidification mode must be enabled. When promoted by thermostat menus, select RTU/AUX DEHUMIDIFIER mode.

### Blower Operation and Adjustments

Units are available with a variety of blower options. See TABLE 3.

**TABLE 3  
BLOWER OPTIONS**

<b>KC 024, 030</b>	Single-Stage, Direct Drive
<b>Single Phase KG 024, 030, 036, 048, 060</b>	Multi-Stage, Direct Drive
<b>Three Phase KG/KC 036, 048, 060</b>	Single-Stage, Direct Drive OR Belt Drive
<b>KGC/KCB 074 S4T</b>	Two-Speed Belt Drive

KGB/KCB074S4T units are equipped with two-stage blowers. The blower will operate at high speed with a Y2 thermostat demand and low speed with a Y1 thermostat demand. Low speed operation delivers approximately 2/3 of the air volume of high speed. Two-speed blower operation results in lower energy consumption. On KGB/KCB074S4T units equipped with hot gas reheat, the blower and compressor will operate on high speed during reheat operation.

## **! IMPORTANT**

Three phase scroll compressors must be phased sequentially for correct compressor and blower rotation. Follow "COOLING START-UP" section of installation instructions to ensure proper compressor and blower operation.

## A-Blower Operation

Initiate blower demand at thermostat according to instructions provided with thermostat. Unit will cycle on thermostat demand. The following steps apply to applications using a typical electro-mechanical thermostat.

- 1 - Blower operation is manually set at the thermostat sub-base fan switch. With fan switch in **ON** position, blowers will operate continuously.
- 2 - With fan switch in **AUTO** position, the blowers will cycle with demand. Blowers and entire unit will be off when system switch is in **OFF** position.

## B-Determining Unit CFM - Single-Speed, Direct Drive Blowers

- 1 - The following measurements must be made with air filters in place.
- 2 - With all access panels in place, measure static pressure external to unit (from supply to return). Add any additional air resistance for options and accessories shown in accessory air resistance tables. Blower performance data is based on static pressure readings taken in locations shown in FIGURE 15.

**NOTE** - Static pressure readings can vary if not taken where shown.

- 3 - Use FIGURE 16 to determine the factory set blower speed.

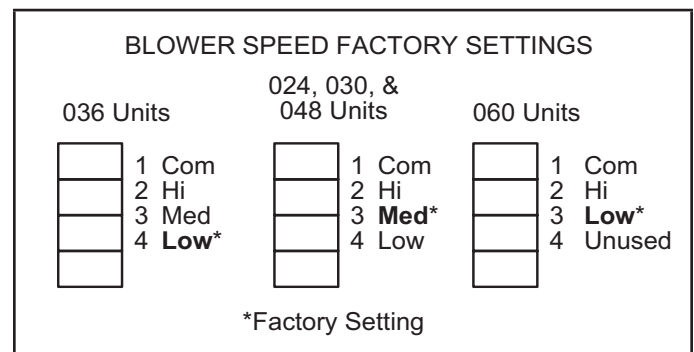

**FIGURE 16**

- 4 - Use direct drive blower tables, the measured static pressure and the factory-set blower speed to determine CFM. If CFM is lower or higher than the design specified CFM, move the leads as shown in FIGURE 17 for 208/230 volt units and FIGURE 18 for 460/575 volt units.



### C-Determining Unit CFM - Multi-Stage, Direct Drive Blowers

- 1 - Refer to multi-stage direct drive blower tables, the measured static pressure, and the factory-set blower speed to determine CFM. Use page 36 when installing units with any of the options or accessories listed.
- 2 - If CFM is lower than the design specified CFM, move the leads as shown in FIGURE 19 for 208/230 volt single phase units.

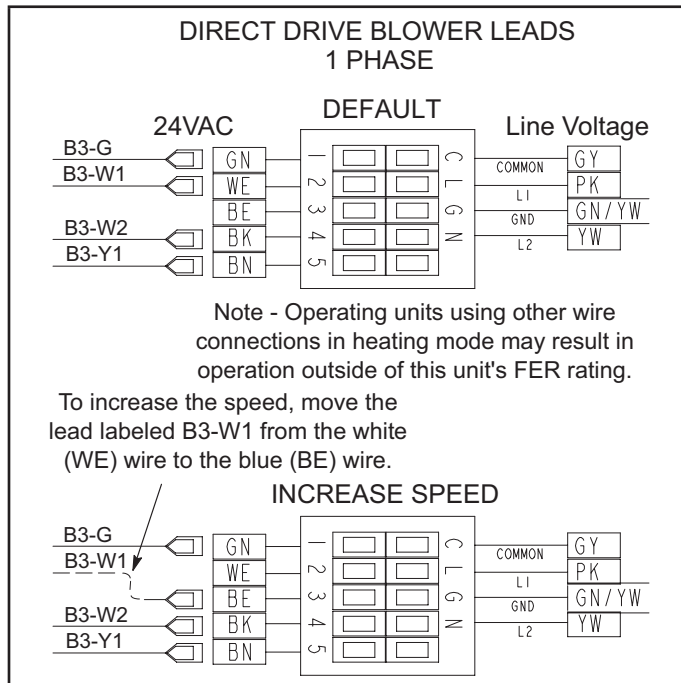

**FIGURE 19**

### D-Determining Unit CFM - Belt Drive Blowers

**IMPORTANT** - KGB/KCB074 blower (G thermostat) **CFM MUST BE ADJUSTED IN HIGH SPEED**. Disconnect factory-installed J350 low speed connector from P350. Connectors are located near the bottom of the control box. Connect J351 high speed connector to P350. Once blower CFM is set, J350 can be reconnected to operate the blower on low during ventilation only demands. See TABLE 4.

- 1 - The following measurements must be made with air filters in place.
- 2 - With all access panels in place, measure static pressure external to unit (from supply to return). Blower performance data is based on static pressure readings taken in locations shown in FIGURE 15.

**NOTE** - Static pressure readings can vary if not taken where shown.

**TABLE 4  
TWO-SPEED BLOWER OPERATION  
KGB/KCB074 UNITS**

Thermostat	Blower Speed
G (P350/J350)*	Low
G (P350/J351)	High
W1	High
W2	High
Y1	Low
Y2	High
Dehum	High

\*Factory-installed jack/plug connection.

- 3 - Measure the indoor blower wheel RPM.
- 4 - Referring to belt drive blower tables, use static pressure and RPM readings to determine unit CFM. Use the air resistance tables when installing units with any of the options or accessories listed.
- 5 - The blower RPM can be adjusted at the motor pulley. Loosen Allen screw and turn adjustable pulley clockwise to increase CFM. Turn counterclockwise to decrease CFM. See FIGURE 20. Do not exceed minimum and maximum number of pulley turns as shown in table 5.
- 6 - KGB/KCB074S4T Unit Only - If low speed during ventilation is desired, replace J351 connector with J350.

**TABLE 5  
MINIMUM AND MAXIMUM PULLEY ADJUSTMENT**

Belt	Min. Turns Open	Max. Turns Open
A Section	No minimum	5

### E-Blower Belt Adjustment

Maximum life and wear can be obtained from belts only if proper pulley alignment and belt tension are maintained. Tension new belts after a 24-48 hour period of operation. This will allow belt to stretch and seat grooves. Make sure blower and motor pulley are aligned as shown in FIGURE 21.

- 1 - Loosen four bolts securing motor base to mounting frame. See FIGURE 20.
- 2 - *To increase belt tension* - Slide blower motor downward to tighten the belt. This increases the distance between the blower motor and the blower housing.
- 3 - *To loosen belt tension* - Slide blower motor upward to loosen the belt. This decreases the distance between the blower motor and the blower housing.
- 4 - Tighten four bolts securing motor base to the mounting frame.



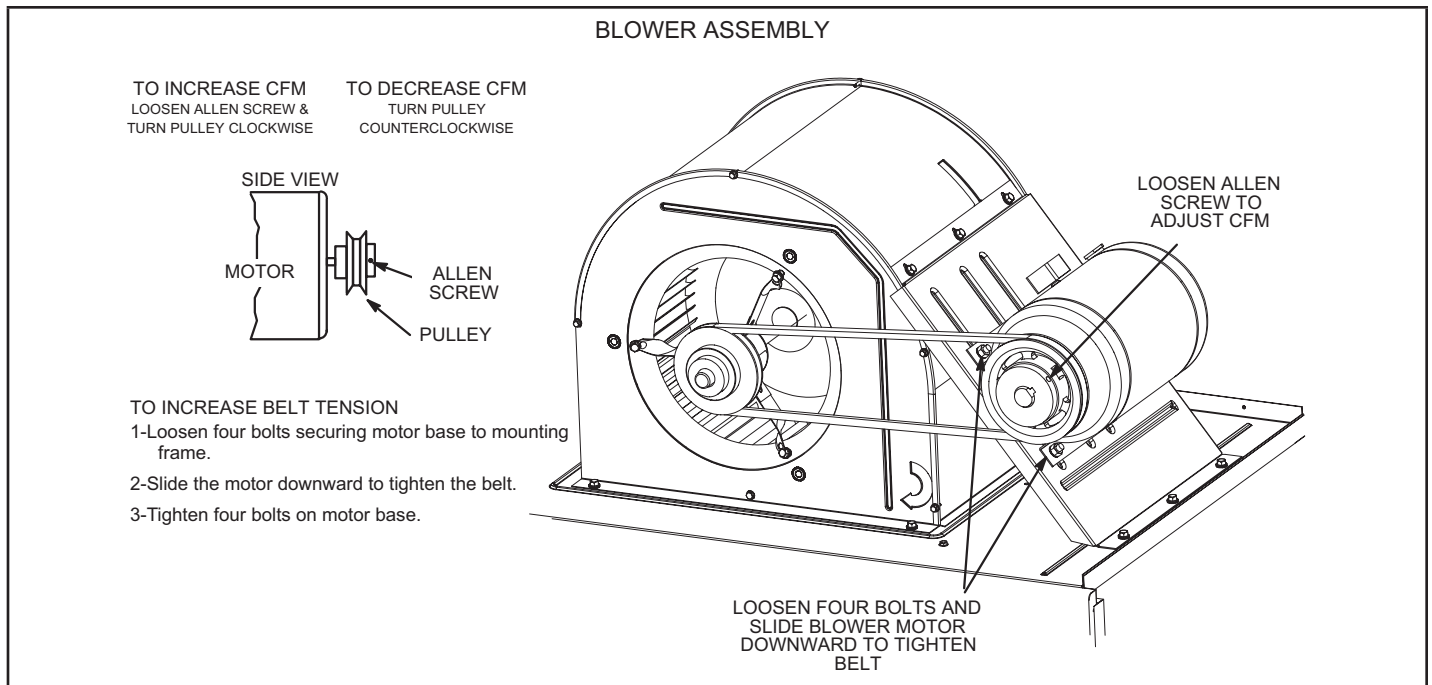

**FIGURE 20**

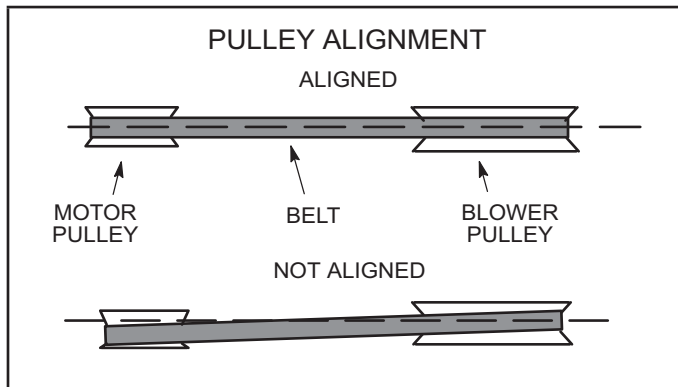

**FIGURE 21**

**F-Blower Belt Adjustment - M Volts Units with 3 HP Blowers Equipped with a Belt Tensioner**

- 1 - Remove blower belt.
- 2 - Remove bracket from blower housing. See FIGURE 23.
- 3 - Remove the screw from the back side of the bracket.
- 4 - Move the tensioner to the appropriate adjustment hole and reinstall screw.
- 5 - Replace bracket.
- 6 - Replace blower belt. See FIGURE 24.

**G-Check Belt Tension - Units not Equipped with a Belt Tensioner**

Overtensioning belts shortens belt and bearing life. Check belt tension as follows:

- 1 - Measure span length X. See FIGURE 22.
- 2 - Apply perpendicular force to center of span (X) with enough pressure to deflect belt 1/64-inch for every inch of span length or 1.5mm per 100mm of span length.

**Example:** Deflection distance of a 40-inch (400 mm) span would be 5/8-inch (6 mm).

**Example:** Deflection distance of a 400mm span would be 6mm.

- 3 - Measure belt deflection force. For a used belt, the deflection force should be 5 lbs. (35kPa). A new belt deflection force should be 7 lbs. (48kPa). A force below these values indicates an undertensioned belt. A force above these values indicates an overtensioned belt.

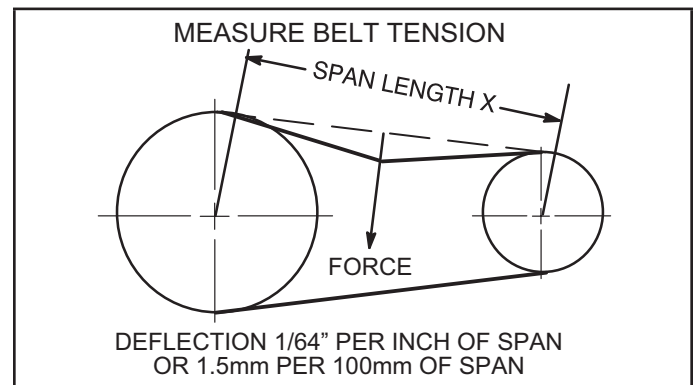

**FIGURE 22**

### H-Field-Furnished Blower Drives

For field-furnished blower drives, use belt drive blower tables to determine BHP and RPM required. Reference the drive kit specification table and manufacturer's drive number table.

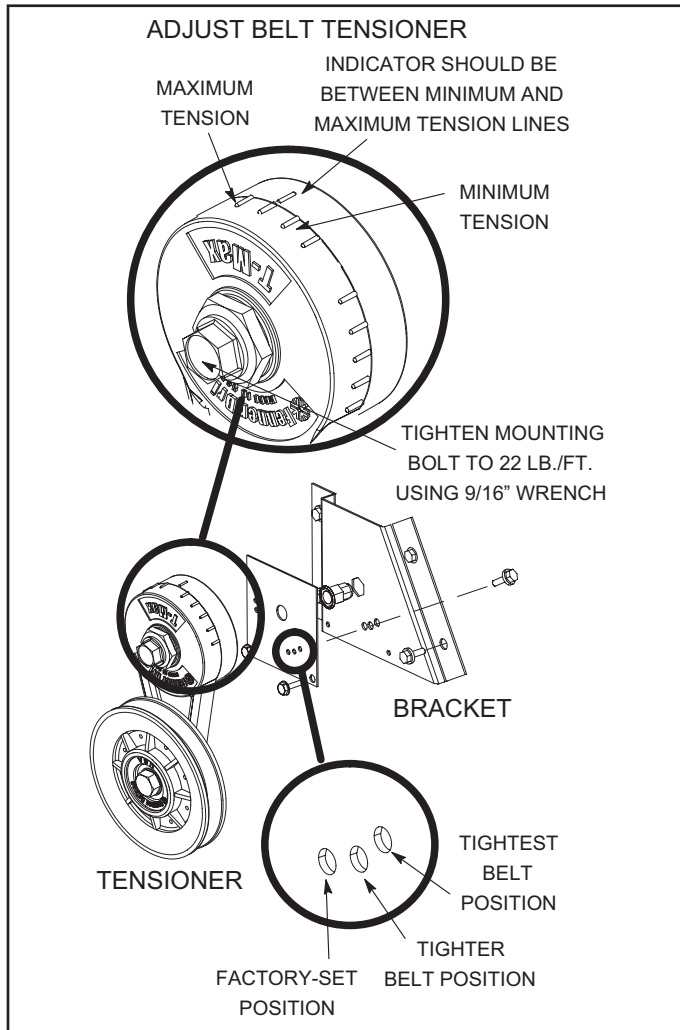

**FIGURE 23**

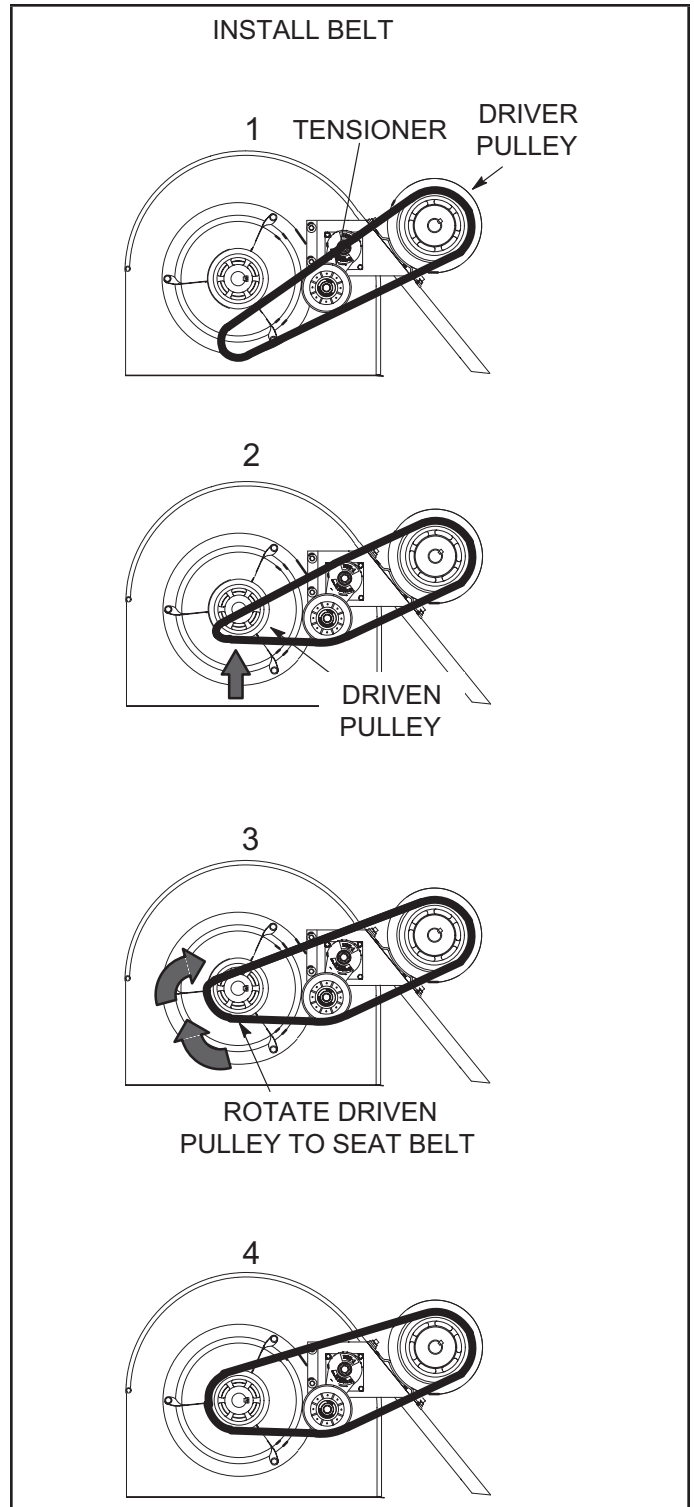

**FIGURE 24**

**BLOWER DATA**

**DIRECT DRIVE ECM**

2 TON - KGB024S4E | 2.5 TON - KGB030S4E

**BLOWER TABLE INCLUDES RESISTANCE FOR BASE UNIT ONLY WITH DRY INDOOR COIL AND AIR FILTERS IN PLACE.**

FOR ALL UNITS ADD:

1 - Any factory installed options air resistance (larger gas heat section, economizer, wet coil, etc.) See page 36.

2 - Any field installed accessories air resistance (duct resistance, diffuser, etc.) See page 36.

**Minimum Air Volume Required For Different Gas Heat Sizes:**

Standard Heat - 1075 cfm

**DOWNFLOW**

External Static Press. in. w.g.	Air Volume (cfm) at Various Blower Speeds					
	Blower Only	Low Speed		High Speed		Free Cooling
	Low and High Speed: G (Pin 1)	Cooling: Y1 (Pin 2 and 5)	1st Stage Heating: W1 (Pin 2) 2nd Stage Heating: W2 (Pin 2 and 4)	1st Stage Heating: W1 (Pin 3) 2nd Stage Heating: W2 (Pin 3 and 4)	Cooling: Y1 (Pin 3 and 5)	Low and High Speed: Y1 (Pin 1 and 5)
0	488	985	1127	1353	1127	1127
0.1	421	913	1082	1311	1082	1082
0.2	333	841	1037	1269	1037	1037
0.3	285	754	988	1224	988	988
0.4	215	668	923	1180	923	923
0.5	---	611	858	1135	858	858
0.6	---	553	809	1076	809	809
0.7	---	481	760	1017	760	760
0.8	---	---	694	972	694	694
0.9	---	---	646	928	646	646
1.0	---	---	580	869	580	580

**HORIZONTAL**

External Static Press. in. w.g.	Air Volume (cfm) at Various Blower Speeds					
	Blower Only	Low Speed		High Speed		Free Cooling
	Low and High Speed: G (Pin 1)	Cooling: Y1 (Pin 2 and 5)	1st Stage Heating: W1 (Pin 2) 2nd Stage Heating: W2 (Pin 2 and 4)	1st Stage Heating: W1 (Pin 3) 2nd Stage Heating: W2 (Pin 3 and 4)	Cooling: Y1 (Pin 3 and 5)	Low and High Speed: Y1 (Pin 1 and 5)
0	479	965	1104	1326	1104	1104
0.1	412	895	1060	1285	1060	1060
0.2	326	824	1016	1244	1016	1016
0.3	280	739	968	1200	968	968
0.4	211	655	905	1156	905	905
0.5	---	599	841	1112	841	841
0.6	---	542	793	1054	793	793
0.7	---	471	745	997	745	745
0.8	---	---	680	953	680	680
0.9	---	---	633	909	633	633
1.0	---	---	568	852	568	568

**BLOWER DATA**

**DIRECT DRIVE ECM**

3 TON - KGB036S4E

**BLOWER TABLE INCLUDES RESISTANCE FOR BASE UNIT ONLY WITH DRY INDOOR COIL AND AIR FILTERS IN PLACE.**

FOR ALL UNITS ADD:

1 - Any factory installed options air resistance (larger gas heat section, economizer, wet coil, etc.) See page 36.

2 - Any field installed accessories air resistance (duct resistance, diffuser, etc.) See page 36.

**Minimum Air Volume Required For Different Gas Heat Sizes:**

Standard Heat - 1075 cfm; Medium Heat - 1150 cfm

**DOWNFLOW**

External Static Press. in. w.g.	Air Volume (cfm) at Various Blower Speeds						
	Blower Only	Low Speed		High Speed			Free Cooling
	Low and High Speed: G (Pin 1)	1st Stage Heating: W1 (Pin 2) Cooling: Y1 (Pin 2 and 5)	2nd Stage Heating: W2 (Pin 2 and 4)	1st Stage Heating: W1 (Pin 3)	2nd Stage Heating: W2 (Pin 3 and 4)	Cooling: Y1 (Pin 3 and 5)	Low and High Speed: Y1 (Pin 1 and 5)
0	862	1375	1567	1706	1840	1567	1567
0.1	809	1330	1539	1682	1780	1539	1539
0.2	741	1277	1511	1658	1748	1511	1511
0.3	680	1253	1477	1624	1712	1477	1477
0.4	622	1200	1443	1598	1677	1443	1443
0.5	555	1150	1409	1564	1638	1409	1409
0.6	---	1095	1364	1530	1608	1364	1364
0.7	---	1052	1330	1496	1577	1330	1330
0.8	---	1004	1296	1444	1528	1296	1296
0.9	---	950	1251	1419	1491	1251	1251
1.0	---	900	1206	1394	1455	1206	1206

**HORIZONTAL**

External Static Press. in. w.g.	Air Volume (cfm) at Various Blower Speeds						
	Blower Only	Low Speed		High Speed			Free Cooling
	Low and High Speed: G (Pin 1)	1st Stage Heating: W1 (Pin 2) Cooling: Y1 (Pin 2 and 5)	2nd Stage Heating: W2 (Pin 2 and 4)	1st Stage Heating: W1 (Pin 3)	2nd Stage Heating: W2 (Pin 3 and 4)	Cooling: Y1 (Pin 3 and 5)	Low and High Speed: Y1 (Pin 1 and 5)
0	479	1379	1536	1672	1810	1536	1536
0.1	412	1305	1508	1648	1749	1508	1508
0.2	326	1264	1481	1625	1718	1481	1481
0.3	280	1216	1447	1592	1677	1447	1447
0.4	211	1173	1414	1566	1649	1414	1414
0.5	---	1131	1381	1533	1622	1381	1381
0.6	---	1078	1337	1499	1577	1337	1337
0.7	---	1038	1303	1466	1544	1303	1303
0.8	---	986	1270	1415	1509	1270	1270
0.9	---	933	1226	1391	1471	1226	1226
1.0	---	885	1182	1366	1438	1182	1182

**BLOWER DATA**

**DIRECT DRIVE ECM**

4 TON - KGB048S4E

**BLOWER TABLE INCLUDES RESISTANCE FOR BASE UNIT ONLY WITH DRY INDOOR COIL AND AIR FILTERS IN PLACE.**

FOR ALL UNITS ADD:

1 - Any factory installed options air resistance (larger gas heat section, economizer, wet coil, etc.) See page 36.

2 - Any field installed accessories air resistance (duct resistance, diffuser, etc.) See page 36.

**Minimum Air Volume Required For Different Gas Heat Sizes:**

Standard Heat - 1075 cfm; Medium Heat - 1150 cfm; High Heat - 1500 cfm

**DOWNFLOW**

External Static Press. in. w.g.	Air Volume (cfm) at Various Blower Speeds					
	Blower Only	Low Speed		High Speed		Free Cooling
	Low and High Speed: G (Pin 1)	Cooling: Y1 (Pin 2 and 5)	1st Stage Heating: W1 (Pin 2) 2nd Stage Heating: W2 (Pin 2 and 4)	2nd Stage Heating: W2 (Pin 3 and 4)	1st Stage Heating: W1 (Pin 3) Cooling: Y1 (Pin 3 and 5)	Low and High Speed: Y1 (Pin 1 and 5)
0	963	1561	1869	2156	1869	1958
0.1	897	1530	1842	2132	1842	1920
0.2	831	1499	1815	2108	1815	1882
0.3	752	1466	1788	2084	1788	1844
0.4	673	1432	1750	2057	1750	1814
0.5	620	1398	1723	2031	1723	1784
0.6	567	1353	1695	1991	1695	1754
0.7	501	1319	1658	1952	1658	1724
0.8	---	1274	1621	1899	1621	1694
0.9	---	1240	1593	1794	1593	1672
1.0	---	1184	1556	1689	1556	1650

**HORIZONTAL**

External Static Press. in. w.g.	Air Volume (cfm) at Various Blower Speeds					
	Blower Only	Low Speed		High Speed		Free Cooling
	Low and High Speed: G (Pin 1)	Cooling: Y1 (Pin 2 and 5)	1st Stage Heating: W1 (Pin 2) 2nd Stage Heating: W2 (Pin 2 and 4)	2nd Stage Heating: W2 (Pin 3 and 4)	1st Stage Heating: W1 (Pin 3) Cooling: Y1 (Pin 3 and 5)	Low and High Speed: Y1 (Pin 1 and 5)
0	944	1530	1832	2113	1832	1919
0.1	879	1499	1805	2089	1805	1882
0.2	814	1469	1779	2066	1779	1844
0.3	737	1437	1752	2042	1752	1807
0.4	660	1403	1715	2016	1715	1778
0.5	608	1370	1689	1990	1689	1748
0.6	556	1326	1661	1951	1661	1719
0.7	491	1293	1625	1913	1625	1690
0.8	---	1249	1589	1861	1589	1660
0.9	---	1215	1561	1758	1561	1639
1.0	---	1160	1525	1655	1525	1617



**BLOWER DATA**

**DIRECT DRIVE ECM**

5 TON - KGB060S4E

**BLOWER TABLE INCLUDES RESISTANCE FOR BASE UNIT ONLY WITH DRY INDOOR COIL AND AIR FILTERS IN PLACE.**

FOR ALL UNITS ADD:

1 - Any factory installed options air resistance (larger gas heat section, economizer, wet coil, etc.) See page 36.

2 - Any field installed accessories air resistance (duct resistance, diffuser, etc.) See page 36.

**Minimum Air Volume Required For Different Gas Heat Sizes:**

Standard Heat - 1075 cfm; Medium Heat - 1150 cfm; High Heat - 1500 cfm

**DOWNFLOW**

External Static Press. in. w.g.	Air Volume (cfm) at Various Blower Speeds						
	Blower Only	Low Speed		High Speed			Free Cooling
	Low and High Speed: G (Pin 1)	1st Stage Heating: W1 (Pin 2) Cooling: Y1 (Pin 2 and 5)	2nd Stage Heating: W2 (Pin 2 and 4)	1st Stage Heating: W1 (Pin 3)	2nd Stage Heating: W2 (Pin 3 and 4)	Cooling: Y1 (Pin 3 and 5)	Low and High Speed: Y1 (Pin 1 and 5)
0	1088	1801	1982	1801	2339	2287	2287
0.1	1042	1769	1956	1769	2310	2251	2251
0.2	996	1736	1928	1736	2281	2215	2215
0.3	948	1703	1900	1703	2253	2178	2178
0.4	883	1669	1870	1669	2224	2142	2142
0.5	835	1634	1838	1634	2195	2106	2106
0.6	787	1598	1806	1598	2166	2058	2058
0.7	723	1561	1772	1561	2137	2010	2010
0.8	658	1524	1736	1524	2108	1937	1937
0.9	594	1486	1700	1486	2080	1841	1841
1.0	546	1446	1662	1446	2051	1696	1696

**HORIZONTAL**

External Static Press. in. w.g.	Air Volume (cfm) at Various Blower Speeds						
	Blower Only	Low Speed		High Speed			Free Cooling
	Low and High Speed: G (Pin 1)	1st Stage Heating: W1 (Pin 2) Cooling: Y1 (Pin 2 and 5)	2nd Stage Heating: W2 (Pin 2 and 4)	1st Stage Heating: W1 (Pin 3)	2nd Stage Heating: W2 (Pin 3 and 4)	Cooling: Y1 (Pin 3 and 5)	Low and High Speed: Y1 (Pin 1 and 5)
0	1066	1728	1886	1728	2206	2241	2241
0.1	1021	1708	1872	1708	2189	2206	2206
0.2	976	1685	1859	1685	2174	2171	2171
0.3	929	1661	1832	1661	2157	2134	2134
0.4	865	1636	1814	1636	2135	2099	2099
0.5	818	1608	1796	1608	2118	2064	2064
0.6	771	1579	1770	1579	2102	2017	2017
0.7	709	1548	1743	1548	2080	1970	1970
0.8	645	1516	1716	1516	2058	1898	1898
0.9	582	1481	1689	1481	2036	1804	1804
1.0	535	1445	1654	1445	2020	1662	1662

**BLOWER DATA**

**DIRECT DRIVE PSC**

3 TON - KGB036S4D | 4 TON - KGB048S4D

**BLOWER TABLE INCLUDES RESISTANCE FOR BASE UNIT ONLY WITH DRY INDOOR COIL AND AIR FILTERS IN PLACE.**

FOR ALL UNITS ADD:

- 1 - Any factory installed options air resistance (larger gas heat section, economizer, wet coil, etc.) See page 36.
- 2 - Any field installed accessories air resistance (duct resistance, diffuser, etc.) See page 36.

**Minimum Air Volume Required For Different Gas Heat Sizes:**

Standard Heat - 1075 cfm; Medium Heat - 1150 cfm; High Heat - 1500 cfm

External Static Pressure (in. w.g.)	Air Volume (cfm) at Various Blower Speeds								
	208 VOLTS			230 VOLTS			460/575 VOLTS		
	High	Medium	Low	High	Medium	Low	High	Medium	Low
<b>3 and 4 Ton Standard Efficiency (Downflow)</b>					<b>KGB036S and KGB048S</b>				
0.0	1873	1561	1123	2094	1783	1321	2064	1727	1216
0.1	1993	1601	1148	2168	1797	1338	2105	1744	1229
0.2	1913	1601	1137	2098	1803	1308	2050	1694	1198
0.3	1858	1527	1078	2036	1725	1261	1987	1638	1167
0.4	1801	1496	1046	1973	1679	1219	1905	1598	1148
0.5	1763	1467	987	1910	1647	1177	1862	1559	1108
0.6	1709	1414	897	1830	1560	1080	1781	1509	1057
0.7	1617	1368	806	1727	1519	986	1698	1449	982
0.8	1472	1269	730	1604	1419	918	1614	1389	920
0.9	1359	1162	487	1478	1363	706	1488	1346	792
1.0	961	922	370	1093	1083	590	1167	1099	703
<b>3 and 4 Ton Standard Efficiency (Horizontal)</b>					<b>KGB036S and KGB048S</b>				
0.0	1799	1530	1073	2012	1747	1263	2015	1756	1251
0.1	1868	1544	1088	2032	1733	1268	2071	1760	1279
0.2	1802	1494	1068	1976	1682	1228	2014	1700	1226
0.3	1735	1432	1014	1900	1618	1185	1937	1634	1187
0.4	1666	1397	980	1825	1568	1142	1878	1597	1174
0.5	1615	1350	904	1750	1516	1078	1801	1558	1124
0.6	1564	1305	842	1675	1440	1014	1743	1479	1060
0.7	1462	1228	758	1562	1364	928	1664	1415	982
0.8	1330	1151	670	1449	1287	842	1512	1335	865
0.9	1194	1011	464	1298	1185	671	1393	1297	733
1.0	878	878	355	998	1032	565	1060	1063	618

**BLOWER DATA**

**DIRECT DRIVE PSC**

**5 TON - KGB060S4D**

**BLOWER TABLE INCLUDES RESISTANCE FOR BASE UNIT ONLY WITH DRY INDOOR COIL AND AIR FILTERS IN PLACE.**

FOR ALL UNITS ADD:

1 - Any factory installed options air resistance (larger gas heat section, economizer, wet coil, etc.) See page 36.

2 - Any field installed accessories air resistance (duct resistance, diffuser, etc.) See page 36.

**Minimum Air Volume Required For Different Gas Heat Sizes:**

Standard Heat - 1075 cfm; Medium Heat - 1150 cfm; High Heat - 1500 cfm

External Static Pressure (in. w.g.)	Air Volume (cfm) at Various Blower Speeds					
	208 VOLTS		230 VOLTS		460/575 VOLTS	
	High	Low	High	Low	High	Low
<b>5 Ton Standard Efficiency (Downflow)</b>						<b>KGB060S</b>
0.0	1940	1581	2131	1788	2131	1788
0.1	1929	1566	2107	1784	2107	1784
0.2	1906	1552	2074	1774	2074	1774
0.3	1872	1546	2036	1752	2036	1752
0.4	1836	1526	1998	1708	1998	1708
0.5	1802	1486	1960	1679	1960	1679
0.6	1749	1447	1904	1635	1904	1635
0.7	1714	1407	1847	1576	1847	1576
0.8	1644	1347	1771	1518	1771	1518
0.9	1574	1245	1658	1430	1658	1430
1.0	1338	---	1506	---	1506	---
<b>5 Ton Standard Efficiency (Horizontal)</b>						<b>KGB060S</b>
0.0	1930	1575	2143	1764	2143	1764
0.1	1920	1573	2115	1761	2115	1761
0.2	1910	1576	2088	1751	2088	1751
0.3	1870	1552	2055	1746	2055	1746
0.4	1840	1524	2023	1704	2023	1704
0.5	1790	1495	1979	1675	1979	1675
0.6	1739	1466	1925	1633	1925	1633
0.7	1679	1428	1860	1590	1860	1590
0.8	1639	1371	1775	1534	1775	1534
0.9	1559	1270	1670	1421	1670	1421
1.0	1438	---	1539	1285	1539	1285

## BLOWER DATA - BELT DRIVE - KGB036S4B

BLOWER TABLE INCLUDES RESISTANCE FOR BASE UNIT ONLY WITH DRY INDOOR COIL AND AIR FILTERS IN PLACE.

FOR ALL UNITS ADD:

1 - Any factory installed options air resistance (larger gas heat section, economizer, wet coil, etc.) See page 36.

2 - Any field installed accessories air resistance (duct resistance, diffuser, etc.) See page 36.

See page 36 for blower motors and drives.

### Minimum Air Volume Required For Different Gas Heat Sizes:

Standard Heat - 1075 cfm; Medium Heat - 1150 cfm

### DOWNFLOW

Air Volume cfm	External Static - in. w.g.															
	0.10		0.20		0.30		0.40		0.50		0.60		0.70		0.80	
	RPM	BHP	RPM	BHP	RPM	BHP	RPM	BHP	RPM	BHP	RPM	BHP	RPM	BHP	RPM	BHP
900	493	0.11	564	0.15	637	0.19	711	0.22	783	0.24	851	0.26	910	0.29	961	0.32
1000	517	0.14	588	0.18	660	0.22	733	0.24	804	0.26	868	0.29	924	0.32	974	0.35
1100	544	0.17	614	0.21	685	0.25	757	0.27	826	0.29	887	0.32	940	0.36	987	0.38
1200	574	0.2	643	0.24	712	0.28	782	0.31	849	0.33	906	0.36	956	0.39	1001	0.42
1300	613	0.23	679	0.28	745	0.31	811	0.34	873	0.36	926	0.40	973	0.43	1016	0.46
1400	662	0.26	722	0.30	781	0.34	841	0.37	897	0.41	944	0.44	989	0.48	1032	0.51
1500	710	0.29	763	0.33	816	0.38	869	0.41	919	0.45	963	0.49	1006	0.53	1049	0.56

Air Volume cfm	External Static - in. w.g.															
	0.90		1.00		1.10		1.20		1.30		1.40		1.50		1.60	
	RPM	BHP	RPM	BHP	RPM	BHP	RPM	BHP	RPM	BHP	RPM	BHP	RPM	BHP	RPM	BHP
900	1008	0.34	1056	0.36	1104	0.39	1149	0.41	1190	0.44	1229	0.46	1267	0.49	1305	0.52
1000	1020	0.37	1067	0.40	1115	0.42	1159	0.45	1200	0.48	1239	0.51	1277	0.54	1314	0.57
1100	1032	0.41	1078	0.43	1124	0.46	1168	0.49	1210	0.52	1249	0.55	1286	0.58	1323	0.62
1200	1045	0.45	1090	0.47	1135	0.50	1178	0.53	1220	0.57	1259	0.60	1296	0.64	1332	0.67
1300	1060	0.49	1104	0.51	1148	0.55	1190	0.58	1230	0.62	1269	0.65	1306	0.69	1342	0.72
1400	1075	0.53	1119	0.56	1162	0.60	1203	0.63	1242	0.67	1280	0.71	1317	0.75	1352	0.78
1500	1093	0.58	1136	0.61	1177	0.65	1217	0.69	1255	0.73	1292	0.77	1328	0.80	1364	0.84

### HORIZONTAL

Air Volume cfm	External Static - in. w.g.															
	0.10		0.20		0.30		0.40		0.50		0.60		0.70		0.80	
	RPM	BHP	RPM	BHP	RPM	BHP	RPM	BHP	RPM	BHP	RPM	BHP	RPM	BHP	RPM	BHP
900	465	0.09	531	0.14	600	0.17	670	0.20	740	0.22	808	0.24	869	0.27	925	0.30
1000	483	0.12	549	0.16	617	0.20	687	0.22	756	0.24	822	0.26	881	0.29	935	0.33
1100	504	0.14	570	0.19	637	0.22	706	0.25	773	0.27	837	0.29	894	0.32	946	0.36
1200	527	0.17	592	0.22	658	0.25	726	0.28	792	0.30	854	0.32	908	0.36	957	0.39
1300	552	0.20	617	0.25	682	0.29	748	0.31	812	0.33	871	0.36	923	0.40	970	0.43
1400	580	0.24	644	0.28	708	0.32	773	0.35	834	0.37	890	0.40	938	0.44	984	0.48
1500	611	0.28	674	0.32	736	0.35	799	0.38	857	0.41	908	0.44	954	0.49	998	0.52

Air Volume cfm	External Static - in. w.g.															
	0.90		1.00		1.10		1.20		1.30		1.40		1.50		1.60	
	RPM	BHP	RPM	BHP	RPM	BHP	RPM	BHP	RPM	BHP	RPM	BHP	RPM	BHP	RPM	BHP
900	977	0.33	1028	0.36	1079	0.39	1127	0.42	1169	0.45	1208	0.48	1246	0.51	1282	0.54
1000	985	0.36	1036	0.39	1087	0.42	1135	0.45	1177	0.48	1216	0.52	1253	0.55	1290	0.58
1100	995	0.39	1044	0.42	1093	0.45	1140	0.49	1183	0.52	1223	0.56	1261	0.59	1297	0.62
1200	1005	0.43	1053	0.46	1100	0.49	1146	0.53	1190	0.56	1230	0.60	1268	0.63	1304	0.67
1300	1016	0.47	1063	0.50	1109	0.53	1154	0.57	1197	0.61	1237	0.64	1275	0.68	1311	0.72
1400	1029	0.51	1074	0.54	1120	0.58	1164	0.61	1205	0.65	1245	0.69	1282	0.73	1318	0.77
1500	1042	0.56	1087	0.59	1132	0.62	1174	0.66	1215	0.71	1253	0.75	1290	0.78	1326	0.82

# BLOWER DATA - BELT DRIVE - KGB048S4B

BLOWER TABLE INCLUDES RESISTANCE FOR BASE UNIT ONLY WITH DRY INDOOR COIL AND AIR FILTERS IN PLACE.

FOR ALL UNITS ADD:

1 - Any factory installed options air resistance (larger gas heat section, economizer, wet coil, etc.) See page 36.

2 - Any field installed accessories air resistance (duct resistance, diffuser, etc.) See page 36.

See page 36 for blower motors and drives.

## Minimum Air Volume Required For Different Gas Heat Sizes:

Standard Heat - 1075 cfm; Medium Heat - 1150 cfm; High Heat - 1500 cfm

### DOWNFLOW

Air Volume cfm	External Static - in. w.g.															
	0.10		0.20		0.30		0.40		0.50		0.60		0.70		0.80	
	RPM	BHP	RPM	BHP	RPM	BHP	RPM	BHP	RPM	BHP	RPM	BHP	RPM	BHP	RPM	BHP
1200	574	0.20	644	0.24	713	0.28	784	0.31	850	0.33	906	0.36	953	0.39	998	0.42
1300	608	0.24	677	0.28	744	0.31	813	0.34	874	0.37	925	0.40	969	0.43	1014	0.46
1400	645	0.28	712	0.31	778	0.35	842	0.38	898	0.41	944	0.44	986	0.48	1030	0.51
1500	684	0.31	749	0.35	811	0.38	871	0.42	921	0.45	963	0.49	1004	0.53	1048	0.56
1600	723	0.35	785	0.39	844	0.43	898	0.46	943	0.50	983	0.54	1024	0.58	1067	0.61
1700	761	0.40	819	0.44	875	0.48	924	0.52	965	0.56	1004	0.60	1045	0.63	1089	0.66
1800	798	0.45	853	0.49	905	0.54	950	0.58	990	0.62	1028	0.66	1069	0.69	1112	0.72
1900	834	0.51	885	0.55	934	0.60	977	0.64	1015	0.68	1054	0.72	1095	0.75	1137	0.79
2000	869	0.57	917	0.62	962	0.67	1004	0.71	1042	0.75	1081	0.78	1121	0.82	1162	0.86

Air Volume cfm	External Static - in. w.g.															
	0.90		1.00		1.10		1.20		1.30		1.40		1.50		1.60	
	RPM	BHP	RPM	BHP	RPM	BHP	RPM	BHP	RPM	BHP	RPM	BHP	RPM	BHP	RPM	BHP
1200	1043	0.44	1090	0.47	1135	0.50	1179	0.53	1220	0.57	1259	0.60	1297	0.64	1333	0.67
1300	1058	0.49	1104	0.51	1148	0.55	1190	0.58	1231	0.62	1269	0.65	1306	0.69	1342	0.72
1400	1074	0.53	1119	0.56	1162	0.59	1203	0.63	1242	0.67	1280	0.71	1317	0.74	1352	0.78
1500	1092	0.58	1136	0.61	1177	0.65	1217	0.69	1255	0.73	1292	0.76	1328	0.80	1364	0.84
1600	1112	0.63	1154	0.67	1193	0.71	1232	0.75	1269	0.79	1306	0.83	1341	0.87	1377	0.91
1700	1132	0.69	1173	0.73	1211	0.77	1248	0.81	1285	0.86	1321	0.90	1356	0.94	1391	0.98
1800	1154	0.76	1194	0.80	1230	0.85	1266	0.89	1302	0.93	1338	0.98	1373	1.02	1408	1.06
1900	1178	0.83	1215	0.88	1250	0.93	1286	0.98	1321	1.02	1356	1.06	1391	1.10	1426	1.14
2000	1201	0.91	1237	0.97	1271	1.02	1307	1.07	1342	1.11	1376	1.15	1411	1.19	1446	1.23

### HORIZONTAL

Air Volume cfm	External Static - in. w.g.															
	0.10		0.20		0.30		0.40		0.50		0.60		0.70		0.80	
	RPM	BHP	RPM	BHP	RPM	BHP	RPM	BHP	RPM	BHP	RPM	BHP	RPM	BHP	RPM	BHP
1200	540	0.18	606	0.22	673	0.26	748	0.29	816	0.30	870	0.33	914	0.37	961	0.40
1300	568	0.21	634	0.26	699	0.29	771	0.32	835	0.34	886	0.37	929	0.41	975	0.44
1400	599	0.25	664	0.29	728	0.33	795	0.35	855	0.38	903	0.41	946	0.45	991	0.49
1500	632	0.29	696	0.33	758	0.36	821	0.39	877	0.42	922	0.46	963	0.50	1008	0.54
1600	667	0.33	729	0.36	789	0.40	848	0.43	898	0.46	941	0.51	982	0.55	1026	0.59
1700	702	0.36	761	0.40	819	0.44	873	0.48	920	0.52	960	0.56	1001	0.61	1044	0.64
1800	737	0.41	794	0.45	848	0.49	898	0.53	941	0.58	981	0.62	1021	0.66	1064	0.70
1900	771	0.46	825	0.50	877	0.54	923	0.59	964	0.64	1002	0.68	1043	0.72	1085	0.76
2000	805	0.51	857	0.56	905	0.61	948	0.66	987	0.71	1025	0.75	1065	0.79	1107	0.82

Air Volume cfm	External Static - in. w.g.															
	0.90		1.00		1.10		1.20		1.30		1.40		1.50		1.60	
	RPM	BHP	RPM	BHP	RPM	BHP	RPM	BHP	RPM	BHP	RPM	BHP	RPM	BHP	RPM	BHP
1200	1010	0.43	1061	0.46	1110	0.50	1156	0.53	1199	0.57	1239	0.61	1276	0.64	1312	0.68
1300	1024	0.47	1073	0.50	1120	0.54	1165	0.58	1207	0.62	1246	0.65	1284	0.69	1320	0.73
1400	1038	0.52	1086	0.55	1131	0.59	1175	0.62	1216	0.66	1255	0.70	1292	0.74	1328	0.78
1500	1054	0.57	1100	0.60	1144	0.64	1186	0.68	1226	0.72	1264	0.75	1301	0.79	1336	0.83
1600	1071	0.62	1116	0.65	1158	0.69	1198	0.73	1237	0.77	1274	0.81	1310	0.85	1345	0.89
1700	1089	0.67	1132	0.71	1172	0.75	1211	0.79	1249	0.83	1285	0.87	1321	0.91	1355	0.95
1800	1108	0.73	1149	0.77	1188	0.81	1225	0.85	1262	0.90	1298	0.94	1332	0.98	1366	1.01
1900	1128	0.79	1167	0.84	1204	0.88	1241	0.92	1276	0.97	1311	1.01	1345	1.05	1379	1.09
2000	1148	0.86	1186	0.91	1221	0.96	1257	1.00	1292	1.05	1326	1.09	1359	1.13	1393	1.17



## BLOWER DATA - BELT DRIVE - KGB060S4B

BLOWER TABLE INCLUDES RESISTANCE FOR BASE UNIT ONLY WITH DRY INDOOR COIL AND AIR FILTERS IN PLACE.

FOR ALL UNITS ADD:

1 - Any factory installed options air resistance (larger gas heat section, economizer, wet coil, etc.) See page 36.

2 - Any field installed accessories air resistance (duct resistance, diffuser, etc.) See page 36.

See page 36 for blower motors and drives.

### Minimum Air Volume Required For Different Gas Heat Sizes:

Standard Heat - 1075 cfm; Medium Heat - 1150 cfm; High Heat - 1500 cfm

#### DOWNFLOW

Air Volume cfm	External Static - in. w.g.															
	0.10		0.20		0.30		0.40		0.50		0.60		0.70		0.80	
	RPM	BHP	RPM	BHP	RPM	BHP	RPM	BHP	RPM	BHP	RPM	BHP	RPM	BHP	RPM	BHP
1600	720	0.28	769	0.33	819	0.37	871	0.41	926	0.44	975	0.47	1016	0.51	1054	0.55
1700	779	0.30	822	0.35	864	0.39	908	0.44	953	0.48	995	0.52	1034	0.57	1072	0.61
1800	828	0.34	864	0.39	901	0.43	938	0.48	977	0.53	1015	0.58	1053	0.63	1091	0.67
1900	858	0.41	892	0.45	927	0.50	962	0.55	999	0.60	1036	0.65	1074	0.69	1112	0.73
2000	879	0.47	913	0.52	948	0.56	984	0.61	1020	0.67	1058	0.72	1096	0.76	1134	0.80
2100	900	0.53	935	0.58	970	0.63	1007	0.69	1044	0.74	1081	0.79	1119	0.84	1157	0.88
2200	922	0.60	958	0.65	994	0.71	1031	0.76	1068	0.82	1106	0.87	1143	0.91	1180	0.95
2300	947	0.67	983	0.73	1020	0.79	1057	0.85	1094	0.90	1131	0.95	1168	1.00	1205	1.03
2400	974	0.76	1010	0.82	1047	0.88	1084	0.94	1120	0.99	1157	1.04	1193	1.08	1230	1.12

Air Volume cfm	External Static - in. w.g.															
	0.90		1.00		1.10		1.20		1.30		1.40		1.50		1.60	
	RPM	BHP	RPM	BHP	RPM	BHP	RPM	BHP	RPM	BHP	RPM	BHP	RPM	BHP	RPM	BHP
1600	1093	0.60	1133	0.63	1173	0.67	1214	0.70	1253	0.73	1288	0.77	1318	0.81	1351	0.85
1700	1111	0.65	1150	0.69	1190	0.72	1230	0.76	1268	0.79	1301	0.83	1331	0.87	1363	0.92
1800	1130	0.71	1169	0.75	1208	0.78	1247	0.82	1285	0.86	1317	0.90	1345	0.94	1377	0.98
1900	1150	0.77	1188	0.81	1227	0.85	1267	0.88	1303	0.92	1333	0.97	1361	1.02	1392	1.06
2000	1172	0.84	1210	0.88	1248	0.92	1286	0.96	1321	1.00	1350	1.05	1377	1.10	1409	1.14
2100	1195	0.91	1233	0.95	1269	1.00	1306	1.04	1339	1.09	1367	1.14	1395	1.19	1426	1.23
2200	1218	0.99	1255	1.03	1290	1.09	1324	1.14	1356	1.19	1385	1.24	1413	1.28	1444	1.32
2300	1242	1.07	1277	1.13	1310	1.20	1343	1.26	1374	1.30	1403	1.34	1432	1.38	1464	1.42
2400	1267	1.16	1300	1.23	1332	1.31	1364	1.37	1394	1.41	1423	1.45	1453	1.48	1484	1.53

#### HORIZONTAL

Air Volume cfm	External Static - in. w.g.															
	0.10		0.20		0.30		0.40		0.50		0.60		0.70		0.80	
	RPM	BHP	RPM	BHP	RPM	BHP	RPM	BHP	RPM	BHP	RPM	BHP	RPM	BHP	RPM	BHP
1600	654	0.28	712	0.32	769	0.36	825	0.39	879	0.43	933	0.47	982	0.50	1024	0.54
1700	703	0.31	756	0.35	807	0.39	858	0.43	906	0.47	955	0.51	999	0.55	1039	0.59
1800	752	0.34	798	0.38	844	0.43	889	0.48	933	0.52	977	0.57	1017	0.61	1056	0.65
1900	796	0.38	837	0.43	878	0.48	918	0.53	958	0.58	997	0.62	1036	0.67	1074	0.71
2000	833	0.43	870	0.48	907	0.54	943	0.59	980	0.64	1018	0.69	1055	0.73	1093	0.77
2100	864	0.50	897	0.55	931	0.60	966	0.65	1002	0.71	1038	0.76	1075	0.80	1113	0.83
2200	887	0.57	920	0.62	953	0.67	988	0.73	1024	0.78	1060	0.83	1097	0.87	1135	0.90
2300	909	0.64	942	0.70	976	0.75	1011	0.81	1046	0.86	1083	0.91	1120	0.95	1157	0.98
2400	931	0.72	965	0.78	999	0.83	1035	0.89	1071	0.94	1108	0.99	1144	1.03	1181	1.07

Air Volume cfm	External Static - in. w.g.															
	0.90		1.00		1.10		1.20		1.30		1.40		1.50		1.60	
	RPM	BHP	RPM	BHP	RPM	BHP	RPM	BHP	RPM	BHP	RPM	BHP	RPM	BHP	RPM	BHP
1600	1063	0.58	1101	0.61	1141	0.64	1181	0.67	1222	0.70	1261	0.73	1298	0.77	1333	0.81
1700	1078	0.63	1117	0.66	1156	0.69	1196	0.72	1235	0.75	1273	0.79	1309	0.83	1344	0.87
1800	1094	0.68	1133	0.72	1172	0.75	1211	0.78	1250	0.81	1287	0.85	1322	0.90	1355	0.94
1900	1112	0.74	1151	0.77	1190	0.81	1228	0.84	1265	0.88	1301	0.92	1335	0.97	1367	1.01
2000	1131	0.80	1170	0.83	1208	0.87	1245	0.91	1281	0.96	1316	1.00	1349	1.04	1380	1.09
2100	1151	0.87	1189	0.90	1227	0.94	1263	0.99	1298	1.04	1331	1.08	1363	1.13	1394	1.17
2200	1173	0.94	1210	0.98	1246	1.02	1281	1.07	1315	1.12	1347	1.17	1379	1.22	1409	1.26
2300	1195	1.02	1231	1.06	1266	1.11	1300	1.16	1333	1.22	1364	1.27	1395	1.32	1424	1.36
2400	1217	1.10	1252	1.15	1286	1.20	1319	1.26	1351	1.32	1382	1.38	1411	1.43	1440	1.48

## BLOWER DATA - BELT DRIVE - DOWNFLOW - KGB074ST

**BLOWER TABLE INCLUDES RESISTANCE FOR BASE UNIT ONLY WITH DRY INDOOR COIL AND AIR FILTERS IN PLACE.**

FOR ALL UNITS ADD:

1 - Any factory installed options air resistance (larger gas heat section, economizer, wet coil, etc.) See page 36.

2 - Any field installed accessories air resistance (duct resistance, diffuser, etc.) See page 36.

See page 36 for blower motors and drives.

### Minimum Air Volume Required For Different Gas Heat Sizes:

Standard Heat - 1075 cfm; Medium Heat - 1150 cfm; High Heat - 1500 cfm

Air Volume cfm	External Static - in. w.g.															
	0.10		0.20		0.30		0.40		0.50		0.60		0.70		0.80	
	RPM	BHP	RPM	BHP	RPM	BHP	RPM	BHP	RPM	BHP	RPM	BHP	RPM	BHP	RPM	BHP
1900	857	0.41	892	0.45	927	0.50	962	0.55	999	0.60	1036	0.65	1074	0.69	1112	0.73
2000	879	0.47	913	0.52	948	0.56	984	0.61	1020	0.67	1058	0.72	1096	0.76	1134	0.80
2100	900	0.53	935	0.58	970	0.63	1007	0.69	1044	0.74	1081	0.79	1119	0.84	1157	0.88
2200	922	0.60	958	0.65	994	0.71	1031	0.76	1068	0.82	1106	0.87	1143	0.91	1180	0.95
2300	947	0.67	983	0.73	1020	0.79	1057	0.85	1094	0.90	1131	0.95	1168	1.00	1205	1.03
2400	974	0.76	1010	0.82	1047	0.88	1084	0.94	1120	0.99	1157	1.04	1193	1.08	1230	1.12
2500	1002	0.85	1039	0.91	1075	0.97	1112	1.03	1148	1.08	1184	1.13	1220	1.17	1257	1.21
2600	1032	0.95	1068	1.01	1105	1.07	1141	1.13	1177	1.17	1213	1.22	1248	1.26	1284	1.31
2700	1062	1.05	1099	1.11	1136	1.17	1172	1.22	1207	1.27	1242	1.32	1277	1.37	1312	1.43
2800	1094	1.16	1131	1.22	1167	1.27	1202	1.32	1237	1.38	1271	1.43	1305	1.49	1339	1.56
2900	1127	1.26	1163	1.32	1198	1.38	1233	1.44	1267	1.50	1300	1.56	1334	1.64	1367	1.71

Air Volume cfm	External Static - in. w.g.															
	0.90		1.00		1.10		1.20		1.30		1.40		1.50		1.60	
	RPM	BHP	RPM	BHP	RPM	BHP	RPM	BHP	RPM	BHP	RPM	BHP	RPM	BHP	RPM	BHP
1900	1150	0.77	1188	0.81	1227	0.85	1267	0.88	1303	0.92	1333	0.97	1360	1.02	1392	1.06
2000	1172	0.84	1210	0.88	1248	0.92	1286	0.96	1321	1.00	1350	1.05	1377	1.10	1409	1.14
2100	1195	0.91	1233	0.95	1269	1.00	1306	1.04	1339	1.09	1367	1.14	1395	1.19	1426	1.23
2200	1218	0.99	1255	1.03	1290	1.09	1324	1.14	1356	1.19	1385	1.24	1413	1.28	1444	1.32
2300	1242	1.07	1277	1.13	1310	1.20	1343	1.26	1374	1.30	1403	1.34	1432	1.38	1464	1.42
2400	1267	1.16	1300	1.23	1332	1.31	1364	1.37	1394	1.41	1423	1.45	1453	1.48	1484	1.53
2500	1292	1.26	1324	1.34	1355	1.42	1387	1.48	1417	1.52	1445	1.56	1475	1.59	1506	1.64
2600	1318	1.38	1350	1.46	1380	1.55	1411	1.60	1440	1.64	1469	1.68	1498	1.71	1529	1.76
2700	1345	1.51	1376	1.60	1406	1.68	1436	1.73	1465	1.77	1493	1.80	1523	1.84	1553	1.88
2800	1372	1.65	1403	1.74	1433	1.82	1462	1.86	1490	1.90	1519	1.93	1548	1.97	1578	2.01
2900	1399	1.80	1430	1.89	1460	1.96	1489	2.00	1516	2.03	1544	2.06	1573	2.10	1603	2.14

## BLOWER DATA - BELT DRIVE - HORIZONTAL - KGB074S4T

BLOWER TABLE INCLUDES RESISTANCE FOR BASE UNIT ONLY WITH DRY INDOOR COIL AND AIR FILTERS IN PLACE.

FOR ALL UNITS ADD:

1 - Any factory installed options air resistance (larger gas heat section, economizer, wet coil, etc.) See page 36.

2 - Any field installed accessories air resistance (duct resistance, diffuser, etc.) See page 36.

See page 36 for blower motors and drives.

### Minimum Air Volume Required For Different Gas Heat Sizes:

Standard Heat - 1075 cfm; Medium Heat - 1150 cfm; High Heat - 1500 cfm

Air Volume cfm	External Static - in. w.g.															
	0.10		0.20		0.30		0.40		0.50		0.60		0.70		0.80	
	RPM	BHP	RPM	BHP	RPM	BHP	RPM	BHP	RPM	BHP	RPM	BHP	RPM	BHP	RPM	BHP
1900	796	0.38	837	0.43	878	0.48	918	0.53	958	0.58	997	0.62	1036	0.67	1074	0.71
2000	833	0.43	870	0.48	907	0.54	943	0.59	980	0.64	1018	0.69	1055	0.73	1093	0.77
2100	864	0.50	897	0.55	931	0.60	966	0.65	1002	0.71	1038	0.76	1075	0.80	1113	0.83
2200	887	0.57	920	0.62	953	0.67	988	0.73	1024	0.78	1060	0.83	1097	0.87	1135	0.90
2300	909	0.64	942	0.70	976	0.75	1011	0.81	1046	0.86	1083	0.91	1120	0.95	1157	0.98
2400	931	0.72	965	0.78	999	0.83	1035	0.89	1071	0.94	1108	0.99	1144	1.03	1181	1.07
2500	955	0.80	989	0.86	1024	0.92	1061	0.98	1097	1.03	1133	1.08	1170	1.11	1205	1.15
2600	981	0.90	1016	0.96	1052	1.01	1088	1.07	1124	1.12	1160	1.16	1195	1.20	1230	1.25
2700	1009	0.99	1044	1.05	1080	1.11	1116	1.16	1152	1.21	1187	1.26	1221	1.30	1254	1.35
2800	1038	1.10	1073	1.16	1109	1.21	1145	1.26	1180	1.31	1214	1.36	1247	1.40	1279	1.46
2900	1068	1.20	1104	1.26	1139	1.31	1174	1.36	1208	1.41	1240	1.47	1273	1.52	1304	1.58

Air Volume cfm	External Static - in. w.g.															
	0.90		1.00		1.10		1.20		1.30		1.40		1.50		1.60	
	RPM	BHP	RPM	BHP	RPM	BHP	RPM	BHP	RPM	BHP	RPM	BHP	RPM	BHP	RPM	BHP
1900	1112	0.74	1151	0.77	1190	0.81	1228	0.84	1265	0.88	1301	0.92	1335	0.97	1367	1.01
2000	1131	0.80	1170	0.83	1208	0.87	1245	0.91	1281	0.96	1316	1.00	1349	1.04	1380	1.09
2100	1151	0.87	1189	0.90	1227	0.94	1263	0.99	1298	1.04	1331	1.08	1363	1.13	1394	1.17
2200	1173	0.94	1210	0.98	1246	1.02	1281	1.07	1315	1.12	1347	1.17	1379	1.22	1409	1.26
2300	1195	1.02	1231	1.06	1266	1.11	1300	1.16	1333	1.22	1364	1.27	1395	1.32	1424	1.36
2400	1217	1.10	1252	1.15	1286	1.20	1319	1.26	1351	1.32	1382	1.38	1411	1.43	1440	1.48
2500	1240	1.20	1274	1.25	1307	1.31	1339	1.37	1370	1.43	1400	1.49	1428	1.55	1457	1.59
2600	1264	1.30	1297	1.35	1329	1.42	1360	1.49	1389	1.55	1418	1.61	1446	1.67	1475	1.72
2700	1287	1.40	1319	1.47	1350	1.54	1380	1.61	1409	1.68	1437	1.74	1465	1.79	1493	1.84
2800	1311	1.52	1342	1.59	1373	1.66	1402	1.74	1430	1.8	1457	1.87	1485	1.92	1513	1.97
2900	1335	1.65	1366	1.72	1395	1.79	1424	1.87	1451	1.94	1478	2.00	1505	2.05	1533	2.09

## BLOWER DATA - DIRECT DRIVE - KCB024S4D

BLOWER TABLE INCLUDES RESISTANCE FOR BASE UNIT ONLY WITH DRY INDOOR COIL AND AIR FILTERS IN PLACE.

FOR ALL UNITS ADD:

1 - Any factory installed options air resistance (economizer, wet coil, etc.) See page 36.

2 - Any field installed accessories air resistance (electric heat, duct resistance, diffuser, etc.) See page 36.

External Static Pressure (in. w.g.)	Air Volume (cfm) at Various Blower Speeds					
	208 VOLTS			230 VOLTS		
	High	Medium	Low	High	Medium	Low
<b>2 Ton Standard Efficiency (Downflow)</b>						<b>KCB024S</b>
0.0	1244	956	859	1414	1098	876
0.1	1226	934	820	1401	1092	870
0.2	1201	906	782	1379	1070	848
0.3	1180	877	727	1348	1039	819
0.4	1152	841	690	1318	1008	775
0.5	1118	812	634	1288	968	746
0.6	1090	768	579	1243	937	702
0.7	1048	725	505	1197	890	659
0.8	1006	667	431	1152	827	600
0.9	950	609	357	1076	749	528
1.0	839	493	248	986	623	468
<b>2 Ton Standard Efficiency (Horizontal)</b>						<b>KCB024S</b>
0.0	1166	910	801	1376	1071	842
0.1	1156	893	770	1342	1054	826
0.2	1136	866	734	1307	1021	808
0.3	1115	826	697	1269	982	771
0.4	1083	800	643	1232	956	734
0.5	1051	747	589	1194	903	698
0.6	1009	707	534	1137	850	662
0.7	946	668	467	1100	797	588
0.8	861	588	396	1024	744	534
0.9	736	508	319	948	652	466
1.0	560	385	237	845	549	392

## BLOWER DATA - DIRECT DRIVE - KCB030S4D

BLOWER TABLE INCLUDES RESISTANCE FOR BASE UNIT ONLY WITH DRY INDOOR COIL AND AIR FILTERS IN PLACE.

FOR ALL UNITS ADD:

1 - Any factory installed options air resistance (economizer, wet coil, etc.) See page 36.

2 - Any field installed accessories air resistance (electric heat, duct resistance, diffuser, etc.) See page 36.

External Static Pressure (in. w.g.)	Air Volume (cfm) at Various Blower Speeds					
	208 VOLTS			230 VOLTS		
	High	Medium	Low	High	Medium	Low
<b>2.5 Ton Standard Efficiency (Downflow)</b>						<b>KCB030S</b>
0.0	1199	928	838	1379	1085	877
0.1	1229	926	813	1409	1086	872
0.2	1206	928	782	1367	1094	850
0.3	1183	881	742	1350	1047	820
0.4	1159	843	686	1321	1009	783
0.5	1136	812	643	1282	981	762
0.6	1103	766	569	1242	921	705
0.7	1046	728	496	1195	888	625
0.8	953	648	432	1134	792	583
0.9	909	584	335	1037	738	492
1.0	783	465	247	926	592	411
<b>2.5 Ton Standard Efficiency (Horizontal)</b>						<b>KCB030S</b>
0.0	1152	909	801	1325	1063	838
0.1	1152	893	770	1321	1048	826
0.2	1136	866	734	1288	1021	798
0.3	1104	826	697	1260	982	771
0.4	1072	787	643	1222	942	734
0.5	1041	747	589	1175	903	698
0.6	1009	707	534	1137	850	662
0.7	946	654	467	1081	797	588
0.8	861	588	396	1024	718	535
0.9	798	508	319	911	642	468
1.0	715	443	237	846	564	394

## BLOWER DATA - DIRECT DRIVE - KCB036SD4, KCB048S4D

BLOWER TABLE INCLUDES RESISTANCE FOR BASE UNIT ONLY WITH DRY INDOOR COIL AND AIR FILTERS IN PLACE.

FOR ALL UNITS ADD:

1 - Any factory installed options air resistance (economizer, wet coil, etc.) See page 36.

2 - Any field installed accessories air resistance (electric heat, duct resistance, diffuser, etc.) See page 36.

External Static Pressure (in. w.g.)	Air Volume (cfm) at Various Blower Speeds								
	208 VOLTS			230 VOLTS			460/575 VOLTS		
	High	Medium	Low	High	Medium	Low	High	Medium	Low
<b>3 and 4 Ton Standard Efficiency (Downflow)</b>					<b>KCB036S and KCB048S</b>				
0.0	1938	1552	1119	2167	1772	1317	2136	1716	1212
0.1	1992	1586	1128	2167	1780	1315	2104	1728	1208
0.2	1915	1592	1137	2100	1792	1307	2052	1684	1197
0.3	1865	1536	1083	2043	1735	1266	1994	1647	1172
0.4	1813	1495	1033	1986	1678	1204	1918	1597	1134
0.5	1762	1444	976	1909	1621	1164	1861	1534	1096
0.6	1694	1391	899	1814	1535	1082	1765	1485	1059
0.7	1609	1331	817	1718	1478	1000	1689	1410	996
0.8	1471	1220	730	1603	1364	918	1613	1335	920
0.9	1368	1066	522	1488	1250	755	1498	1235	848
1.0	1108	869	402	1259	1021	640	1345	1036	763
<b>3 and 4 Ton Standard Efficiency (Horizontal)</b>					<b>KCB036S and KCB048S</b>				
0.0	1862	1520	1070	2082	1736	1259	2085	1745	1247
0.1	1867	1530	1069	2031	1717	1246	2070	1744	1257
0.2	1804	1485	1067	1978	1672	1227	2016	1690	1225
0.3	1741	1440	1018	1907	1627	1190	1944	1643	1192
0.4	1677	1396	968	1837	1567	1128	1890	1596	1160
0.5	1614	1329	894	1749	1492	1066	1800	1533	1111
0.6	1550	1284	844	1660	1417	1016	1727	1455	1062
0.7	1455	1195	769	1554	1327	941	1655	1377	996
0.8	1329	1106	670	1448	1237	842	1511	1283	865
0.9	1202	927	496	1307	1087	718	1403	1190	784
1.0	1012	828	385	1025	973	613	1222	1002	670



## BLOWER DATA - DIRECT DRIVE - KCB060S4D

BLOWER TABLE INCLUDES RESISTANCE FOR BASE UNIT ONLY WITH DRY INDOOR COIL AND AIR FILTERS IN PLACE.

FOR ALL UNITS ADD:

1 - Any factory installed options air resistance (economizer, wet coil, etc.) See page 36.

2 - Any field installed accessories air resistance (electric heat, duct resistance, diffuser, etc.) See page 36.

External Static Pressure (in. w.g.)	Air Volume (cfm) at Various Blower Speeds					
	208 VOLTS		230 VOLTS		460/575 VOLTS	
	High	Low	High	Low	High	Low
<b>5 Ton Standard Efficiency (Downflow)</b>						<b>KCB060S</b>
0.0	1883	1570	2074	1785	2074	1785
0.1	1871	1550	2050	1760	2050	1760
0.2	1855	1538	2018	1735	2018	1735
0.3	1828	1523	1986	1704	1986	1704
0.4	1786	1499	1937	1679	1937	1679
0.5	1759	1476	1905	1642	1905	1642
0.6	1718	1452	1856	1605	1856	1605
0.7	1676	1421	1791	1567	1791	1567
0.8	1622	1358	1726	1505	1726	1505
0.9	1539	1277	1628	1406	1628	1406
1.0	1399	- - -	1502	1300	1502	1300
<b>5 Ton Standard Efficiency (Horizontal)</b>						<b>KCB060S</b>
0.0	1852	1534	2046	1713	2046	1713
0.1	1844	1532	2024	1711	2024	1711
0.2	1831	1526	1998	1706	1998	1706
0.3	1800	1504	1954	1681	1954	1681
0.4	1769	1477	1918	1654	1918	1654
0.5	1722	1450	1865	1612	1865	1612
0.6	1674	1423	1812	1570	1812	1570
0.7	1627	1369	1742	1515	1742	1515
0.8	1565	1315	1672	1459	1672	1459
0.9	1470	1241	1530	1376	1530	1376
1.0	1323	- - -	1426	1242	1426	1242

## BLOWER DATA - BELT DRIVE - KCB036S4B

BLOWER TABLE INCLUDES RESISTANCE FOR BASE UNIT ONLY WITH DRY INDOOR COIL AND AIR FILTERS IN PLACE.

FOR ALL UNITS ADD:

1 - Any factory installed options air resistance (economizer, wet coil, etc.) See page 36.

2 - Any field installed accessories air resistance (electric heat, duct resistance, diffuser, etc.) See page 36.

See page 36 for blower motors and drives.

### DOWNFLOW

Air Volume cfm	External Static - in. w.g.															
	0.10		0.20		0.30		0.40		0.50		0.60		0.70		0.80	
	RPM	BHP	RPM	BHP	RPM	BHP	RPM	BHP	RPM	BHP	RPM	BHP	RPM	BHP	RPM	BHP
900	486	0.12	554	0.16	623	0.20	695	0.22	767	0.23	836	0.25	897	0.28	953	0.30
1000	508	0.15	576	0.19	643	0.22	713	0.24	783	0.26	848	0.28	907	0.30	961	0.33
1100	533	0.18	599	0.22	665	0.25	733	0.27	800	0.28	863	0.31	919	0.34	971	0.36
1200	560	0.21	625	0.25	689	0.28	755	0.30	820	0.32	879	0.34	932	0.37	983	0.40
1300	591	0.24	654	0.28	716	0.31	779	0.33	841	0.35	897	0.38	948	0.41	996	0.44
1400	631	0.26	690	0.30	748	0.34	807	0.36	864	0.39	916	0.42	964	0.46	1011	0.49
1500	676	0.28	729	0.33	782	0.36	835	0.40	887	0.43	935	0.47	981	0.50	1028	0.54

Air Volume cfm	External Static - in. w.g.															
	0.90		1.00		1.10		1.20		1.30		1.40		1.50		1.60	
	RPM	BHP	RPM	BHP	RPM	BHP	RPM	BHP	RPM	BHP	RPM	BHP	RPM	BHP	RPM	BHP
900	1004	0.33	1055	0.35	1106	0.37	1152	0.40	1193	0.43	1232	0.46	1269	0.49	1305	0.52
1000	1011	0.36	1062	0.38	1111	0.41	1157	0.43	1199	0.47	1238	0.50	1276	0.53	1311	0.56
1100	1020	0.39	1070	0.41	1118	0.44	1163	0.47	1206	0.51	1245	0.54	1282	0.58	1318	0.61
1200	1031	0.43	1079	0.45	1127	0.48	1171	0.52	1213	0.55	1252	0.59	1289	0.62	1324	0.66
1300	1044	0.47	1091	0.49	1137	0.53	1181	0.56	1221	0.60	1259	0.64	1296	0.68	1330	0.71
1400	1058	0.51	1105	0.54	1150	0.57	1191	0.61	1231	0.65	1268	0.69	1303	0.73	1337	0.77
1500	1074	0.56	1120	0.59	1163	0.63	1203	0.67	1241	0.71	1277	0.75	1312	0.79	1345	0.82

### HORIZONTAL

Air Volume cfm	External Static - in. w.g.															
	0.10		0.20		0.30		0.40		0.50		0.60		0.70		0.80	
	RPM	BHP	RPM	BHP	RPM	BHP	RPM	BHP	RPM	BHP	RPM	BHP	RPM	BHP	RPM	BHP
900	485	0.11	554	0.14	627	0.16	703	0.18	780	0.21	841	0.23	888	0.27	935	0.30
1000	509	0.13	578	0.16	649	0.19	722	0.21	796	0.23	854	0.26	900	0.29	947	0.33
1100	537	0.16	605	0.19	674	0.21	744	0.24	813	0.26	868	0.29	913	0.33	959	0.36
1200	567	0.19	633	0.22	700	0.24	768	0.27	833	0.30	884	0.33	928	0.37	974	0.40
1300	599	0.22	664	0.25	729	0.28	793	0.30	853	0.33	902	0.37	945	0.41	990	0.44
1400	634	0.26	697	0.29	758	0.31	819	0.34	875	0.38	921	0.42	964	0.46	1008	0.49
1500	669	0.30	730	0.33	789	0.36	846	0.39	897	0.42	941	0.47	983	0.51	1028	0.54

Air Volume cfm	External Static - in. w.g.															
	0.90		1.00		1.10		1.20		1.30		1.40		1.50		1.60	
	RPM	BHP	RPM	BHP	RPM	BHP	RPM	BHP	RPM	BHP	RPM	BHP	RPM	BHP	RPM	BHP
900	986	0.32	1039	0.35	1090	0.37	1137	0.40	1177	0.43	1214	0.46	1248	0.49	1280	0.51
1000	997	0.35	1048	0.38	1098	0.41	1143	0.44	1184	0.47	1221	0.50	1255	0.53	1287	0.56
1100	1008	0.39	1059	0.41	1107	0.44	1150	0.47	1191	0.51	1228	0.54	1263	0.57	1295	0.60
1200	1022	0.43	1071	0.45	1117	0.48	1160	0.52	1200	0.55	1237	0.59	1271	0.62	1303	0.66
1300	1037	0.47	1085	0.50	1130	0.53	1171	0.57	1210	0.60	1246	0.64	1280	0.68	1312	0.71
1400	1054	0.52	1100	0.54	1144	0.58	1183	0.62	1221	0.66	1256	0.70	1290	0.73	1321	0.77
1500	1073	0.57	1117	0.60	1159	0.64	1197	0.67	1234	0.71	1268	0.75	1301	0.79	1332	0.83

# BLOWER DATA - BELT DRIVE - KCB048S4B

BLOWER TABLE INCLUDES RESISTANCE FOR BASE UNIT ONLY WITH DRY INDOOR COIL AND AIR FILTERS IN PLACE.

FOR ALL UNITS ADD:

- 1 - Any factory installed options air resistance (economizer, wet coil, etc.) See page 36.
- 2 - Any field installed accessories air resistance (electric heat, duct resistance, diffuser, etc.) See page 36.

See page 36 for blower motors and drives.

## DOWNFLOW

Air Volume cfm	External Static - in. w.g.															
	0.10		0.20		0.30		0.40		0.50		0.60		0.70		0.80	
	RPM	BHP	RPM	BHP	RPM	BHP	RPM	BHP	RPM	BHP	RPM	BHP	RPM	BHP	RPM	BHP
1200	560	0.21	625	0.25	689	0.28	755	0.30	820	0.32	879	0.34	932	0.37	983	0.40
1300	591	0.24	654	0.28	716	0.31	779	0.33	841	0.35	897	0.38	948	0.41	996	0.44
1400	631	0.26	690	0.30	748	0.34	807	0.36	864	0.39	916	0.42	964	0.46	1011	0.49
1500	675	0.28	729	0.33	782	0.36	835	0.40	887	0.43	935	0.47	981	0.50	1028	0.54
1600	718	0.31	766	0.35	814	0.40	862	0.44	910	0.48	955	0.52	1000	0.55	1046	0.59
1700	756	0.34	799	0.39	843	0.44	887	0.49	932	0.53	976	0.57	1020	0.61	1066	0.64
1800	787	0.40	828	0.45	870	0.50	912	0.55	955	0.59	999	0.63	1043	0.67	1089	0.70
1900	815	0.46	855	0.51	897	0.57	939	0.62	981	0.66	1024	0.69	1068	0.73	1113	0.76
2000	843	0.53	884	0.59	925	0.64	968	0.68	1009	0.72	1052	0.76	1095	0.79	1138	0.83

Air Volume cfm	External Static - in. w.g.															
	0.90		1.00		1.10		1.20		1.30		1.40		1.50		1.60	
	RPM	BHP	RPM	BHP	RPM	BHP	RPM	BHP	RPM	BHP	RPM	BHP	RPM	BHP	RPM	BHP
1200	1031	0.43	1079	0.45	1127	0.48	1171	0.52	1213	0.55	1252	0.59	1289	0.62	1324	0.66
1300	1044	0.47	1091	0.49	1137	0.53	1181	0.56	1221	0.60	1259	0.64	1296	0.68	1330	0.71
1400	1058	0.51	1105	0.54	1150	0.57	1191	0.61	1231	0.65	1268	0.69	1303	0.73	1337	0.77
1500	1074	0.56	1120	0.59	1163	0.63	1203	0.67	1241	0.71	1277	0.75	1312	0.79	1345	0.82
1600	1092	0.61	1137	0.65	1178	0.68	1216	0.72	1253	0.76	1288	0.80	1321	0.84	1354	0.88
1700	1112	0.67	1155	0.70	1193	0.75	1230	0.79	1265	0.83	1299	0.87	1332	0.91	1364	0.95
1800	1133	0.73	1174	0.77	1209	0.81	1244	0.85	1278	0.90	1311	0.94	1343	0.98	1375	1.02
1900	1156	0.80	1193	0.84	1226	0.89	1260	0.93	1293	0.97	1325	1.01	1356	1.06	1388	1.10
2000	1178	0.87	1213	0.92	1243	0.97	1275	1.02	1307	1.06	1339	1.10	1370	1.14	---	---

## HORIZONTAL

Air Volume cfm	External Static - in. w.g.															
	0.10		0.20		0.30		0.40		0.50		0.60		0.70		0.80	
	RPM	BHP	RPM	BHP	RPM	BHP	RPM	BHP	RPM	BHP	RPM	BHP	RPM	BHP	RPM	BHP
1200	567	0.19	633	0.22	700	0.24	768	0.27	833	0.30	884	0.33	928	0.37	974	0.40
1300	599	0.22	664	0.25	729	0.28	793	0.30	853	0.33	902	0.37	945	0.41	990	0.44
1400	634	0.26	697	0.29	758	0.31	819	0.34	875	0.38	921	0.42	964	0.46	1008	0.49
1500	669	0.30	730	0.33	789	0.36	846	0.39	897	0.42	941	0.47	983	0.51	1028	0.54
1600	705	0.34	763	0.37	819	0.40	873	0.43	921	0.48	963	0.52	1004	0.56	1048	0.59
1700	741	0.38	796	0.41	850	0.45	900	0.49	945	0.53	985	0.58	1026	0.62	1070	0.65
1800	776	0.43	829	0.46	880	0.51	927	0.55	970	0.60	1009	0.64	1050	0.68	1093	0.71
1900	812	0.48	862	0.52	910	0.57	955	0.62	996	0.66	1035	0.71	1076	0.74	1118	0.78
2000	847	0.54	895	0.59	941	0.64	984	0.69	1023	0.74	1062	0.78	1103	0.81	1144	0.85

Air Volume cfm	External Static - in. w.g.															
	0.90		1.00		1.10		1.20		1.30		1.40		1.50		1.60	
	RPM	BHP	RPM	BHP	RPM	BHP	RPM	BHP	RPM	BHP	RPM	BHP	RPM	BHP	RPM	BHP
1200	1022	0.43	1071	0.45	1117	0.48	1160	0.52	1200	0.55	1237	0.59	1271	0.62	1303	0.66
1300	1037	0.47	1085	0.50	1130	0.53	1171	0.57	1210	0.60	1246	0.64	1280	0.68	1312	0.71
1400	1054	0.52	1100	0.54	1144	0.58	1183	0.62	1221	0.66	1256	0.70	1290	0.73	1321	0.77
1500	1073	0.57	1117	0.60	1159	0.64	1197	0.67	1234	0.71	1268	0.75	1301	0.79	1332	0.83
1600	1093	0.62	1136	0.66	1175	0.70	1212	0.74	1247	0.78	1281	0.82	1313	0.86	1344	0.90
1700	1114	0.68	1155	0.72	1192	0.76	1227	0.80	1262	0.85	1295	0.89	1327	0.93	1358	0.97
1800	1136	0.75	1175	0.79	1210	0.83	1245	0.88	1278	0.92	1311	0.97	1342	1.01	1373	1.05
1900	1159	0.82	1197	0.86	1229	0.92	1263	0.97	1296	1.01	1328	1.06	1359	1.10	1390	1.14
2000	1183	0.90	1218	0.95	1249	1.01	1282	1.06	1314	1.11	1346	1.15	---	---	---	---

# BLOWER DATA - BELT DRIVE - KCB060S4B

BLOWER TABLE INCLUDES RESISTANCE FOR BASE UNIT ONLY WITH DRY INDOOR COIL AND AIR FILTERS IN PLACE.

FOR ALL UNITS ADD:

- 1 - Any factory installed options air resistance (economizer, wet coil, etc.) See page 36.
- 2 - Any field installed accessories air resistance (electric heat, duct resistance, diffuser, etc.) See page 36.

See page 36 for blower motors and drives.

## DOWNFLOW

Air Volume cfm	External Static - in. w.g.															
	0.10		0.20		0.30		0.40		0.50		0.60		0.70		0.80	
	RPM	BHP	RPM	BHP	RPM	BHP	RPM	BHP	RPM	BHP	RPM	BHP	RPM	BHP	RPM	BHP
1600	665	0.30	716	0.34	768	0.38	819	0.41	879	0.44	937	0.46	985	0.49	1022	0.52
1700	723	0.31	768	0.35	814	0.39	860	0.43	910	0.47	959	0.50	1001	0.54	1037	0.58
1800	779	0.32	818	0.37	857	0.41	897	0.46	939	0.50	980	0.55	1018	0.59	1054	0.64
1900	826	0.36	859	0.41	894	0.45	928	0.50	964	0.56	1000	0.61	1036	0.66	1072	0.70
2000	857	0.42	889	0.47	920	0.52	952	0.57	986	0.62	1020	0.68	1055	0.73	1091	0.77
2100	878	0.49	909	0.54	940	0.59	973	0.64	1006	0.70	1041	0.75	1076	0.80	1112	0.85
2200	897	0.55	929	0.61	961	0.66	994	0.72	1028	0.78	1063	0.83	1099	0.89	1134	0.93
2300	918	0.62	950	0.68	983	0.74	1017	0.80	1052	0.86	1087	0.92	1122	0.97	1157	1.02
2400	941	0.70	974	0.77	1008	0.83	1042	0.90	1077	0.96	1111	1.01	1146	1.06	1181	1.11

Air Volume cfm	External Static - in. w.g.															
	0.90		1.00		1.10		1.20		1.30		1.40		1.50		1.60	
	RPM	BHP	RPM	BHP	RPM	BHP	RPM	BHP	RPM	BHP	RPM	BHP	RPM	BHP	RPM	BHP
1600	1059	0.57	1098	0.61	1138	0.65	1177	0.68	1218	0.71	1257	0.75	1290	0.79	1319	0.83
1700	1074	0.62	1113	0.66	1152	0.70	1190	0.74	1231	0.77	1268	0.80	1299	0.84	1328	0.89
1800	1091	0.68	1129	0.72	1167	0.76	1205	0.80	1244	0.83	1280	0.87	1310	0.91	1338	0.95
1900	1109	0.75	1146	0.79	1183	0.82	1221	0.86	1260	0.90	1294	0.94	1323	0.98	1349	1.02
2000	1128	0.82	1164	0.86	1201	0.89	1239	0.93	1276	0.97	1310	1.01	1336	1.06	1362	1.10
2100	1148	0.89	1185	0.93	1221	0.97	1258	1.01	1294	1.05	1325	1.09	1351	1.14	1376	1.19
2200	1170	0.97	1206	1.01	1242	1.05	1277	1.09	1311	1.14	1341	1.18	1365	1.23	1390	1.28
2300	1193	1.06	1228	1.09	1262	1.14	1295	1.19	1327	1.24	1355	1.29	1380	1.33	1406	1.37
2400	1216	1.15	1250	1.19	1282	1.24	1313	1.30	1343	1.36	1371	1.40	1396	1.44	1423	1.48

## HORIZONTAL

Air Volume cfm	External Static - in. w.g.															
	0.10		0.20		0.30		0.40		0.50		0.60		0.70		0.80	
	RPM	BHP	RPM	BHP	RPM	BHP	RPM	BHP	RPM	BHP	RPM	BHP	RPM	BHP	RPM	BHP
1600	712	0.29	758	0.32	807	0.36	855	0.39	906	0.43	955	0.46	997	0.50	1035	0.54
1700	766	0.32	808	0.36	850	0.40	892	0.44	936	0.47	978	0.51	1016	0.56	1052	0.60
1800	814	0.36	851	0.40	888	0.44	925	0.49	963	0.53	1000	0.57	1035	0.62	1071	0.66
1900	853	0.41	886	0.46	919	0.50	952	0.55	986	0.60	1021	0.64	1056	0.69	1091	0.73
2000	883	0.48	913	0.53	944	0.57	976	0.62	1009	0.67	1043	0.71	1078	0.76	1112	0.80
2100	906	0.56	936	0.60	967	0.65	999	0.70	1033	0.75	1067	0.79	1101	0.84	1135	0.88
2200	930	0.64	960	0.68	991	0.73	1024	0.78	1058	0.83	1092	0.88	1126	0.92	1160	0.96
2300	954	0.72	985	0.77	1017	0.82	1051	0.87	1085	0.92	1119	0.96	1152	1.00	1186	1.04
2400	981	0.81	1013	0.86	1046	0.91	1079	0.96	1113	1.00	1146	1.05	1180	1.09	1213	1.13

Air Volume cfm	External Static - in. w.g.															
	0.90		1.00		1.10		1.20		1.30		1.40		1.50		1.60	
	RPM	BHP	RPM	BHP	RPM	BHP	RPM	BHP	RPM	BHP	RPM	BHP	RPM	BHP	RPM	BHP
1600	1071	0.58	1109	0.62	1147	0.66	1186	0.69	1225	0.72	1263	0.76	1299	0.80	1334	0.83
1700	1088	0.64	1126	0.68	1164	0.72	1202	0.75	1240	0.78	1276	0.82	1311	0.86	1345	0.90
1800	1107	0.70	1143	0.74	1181	0.78	1219	0.81	1256	0.85	1291	0.89	1324	0.93	1357	0.97
1900	1126	0.77	1163	0.81	1200	0.85	1237	0.88	1273	0.92	1306	0.96	1339	1.00	1371	1.04
2000	1148	0.84	1183	0.88	1220	0.92	1257	0.96	1291	1.00	1323	1.04	1354	1.08	1385	1.12
2100	1170	0.92	1206	0.96	1242	1.00	1277	1.04	1310	1.08	1340	1.13	1371	1.17	1401	1.21
2200	1195	1.00	1230	1.04	1265	1.08	1299	1.13	1330	1.18	1359	1.23	1388	1.27	1418	1.31
2300	1220	1.08	1254	1.13	1288	1.17	1320	1.23	1350	1.28	1378	1.34	1406	1.38	1435	1.42
2400	1245	1.18	1278	1.22	1311	1.28	1341	1.33	1370	1.40	1397	1.45	1425	1.50	1454	1.54

## BLOWER DATA - BELT DRIVE - KCB074S4T - DOWNFLOW

BLOWER TABLE INCLUDES RESISTANCE FOR BASE UNIT ONLY WITH DRY INDOOR COIL AND AIR FILTERS IN PLACE.

FOR ALL UNITS ADD:

1 - Any factory installed options air resistance (economizer, wet coil, etc.) See page 36.

2 - Any field installed accessories air resistance (electric heat, duct resistance, diffuser, etc.) See page 36.

See page 36 for blower motors and drives.

Air Volume cfm	External Static - in. w.g.															
	0.10		0.20		0.30		0.40		0.50		0.60		0.70		0.80	
	RPM	BHP	RPM	BHP	RPM	BHP	RPM	BHP	RPM	BHP	RPM	BHP	RPM	BHP	RPM	BHP
1900	826	0.36	859	0.41	894	0.45	928	0.50	964	0.56	1000	0.61	1036	0.66	1072	0.70
2000	857	0.42	889	0.47	920	0.52	952	0.57	986	0.62	1020	0.68	1055	0.73	1091	0.77
2100	878	0.49	909	0.54	940	0.59	973	0.64	1006	0.70	1041	0.75	1076	0.80	1112	0.85
2200	897	0.55	929	0.61	961	0.66	994	0.72	1028	0.78	1063	0.83	1099	0.89	1134	0.93
2300	918	0.62	950	0.68	983	0.74	1017	0.80	1052	0.86	1087	0.92	1122	0.97	1157	1.02
2400	941	0.70	974	0.77	1008	0.83	1042	0.90	1077	0.96	1111	1.01	1146	1.06	1181	1.11
2500	966	0.79	1000	0.86	1034	0.93	1068	1.00	1103	1.06	1137	1.11	1171	1.16	1205	1.20
2600	994	0.90	1028	0.97	1062	1.04	1096	1.10	1130	1.16	1164	1.21	1197	1.26	1231	1.30
2700	1023	1.01	1057	1.08	1091	1.15	1125	1.22	1159	1.27	1192	1.32	1225	1.37	1258	1.41
2800	1053	1.13	1088	1.21	1122	1.27	1155	1.33	1188	1.39	1221	1.43	1253	1.48	1286	1.53
2900	1085	1.26	1119	1.33	1153	1.40	1186	1.45	1218	1.51	1250	1.55	1281	1.61	1313	1.66

Air Volume cfm	External Static - in. w.g.															
	0.90		1.00		1.10		1.20		1.30		1.40		1.50		1.60	
	RPM	BHP	RPM	BHP	RPM	BHP	RPM	BHP	RPM	BHP	RPM	BHP	RPM	BHP	RPM	BHP
1900	1109	0.75	1146	0.79	1183	0.82	1221	0.86	1260	0.90	1294	0.94	1323	0.98	1349	1.02
2000	1128	0.82	1164	0.86	1201	0.89	1239	0.93	1276	0.97	1310	1.01	1336	1.06	1362	1.10
2100	1148	0.89	1185	0.93	1221	0.97	1258	1.01	1294	1.05	1325	1.09	1351	1.14	1376	1.19
2200	1170	0.97	1206	1.01	1242	1.05	1277	1.09	1311	1.14	1341	1.18	1365	1.23	1390	1.28
2300	1193	1.06	1228	1.09	1262	1.14	1295	1.19	1327	1.24	1355	1.29	1380	1.33	1406	1.37
2400	1216	1.15	1250	1.19	1282	1.24	1313	1.30	1343	1.36	1371	1.40	1396	1.44	1423	1.48
2500	1240	1.24	1273	1.29	1302	1.36	1331	1.42	1360	1.48	1388	1.52	1414	1.55	1441	1.58
2600	1265	1.34	1296	1.40	1324	1.47	1352	1.54	1381	1.60	1408	1.64	1434	1.67	1460	1.70
2700	1291	1.46	1321	1.52	1347	1.60	1374	1.67	1403	1.72	1429	1.76	1455	1.79	1481	1.82
2800	1317	1.58	1346	1.66	1372	1.74	1399	1.80	1426	1.85	1451	1.89	1477	1.92	1503	1.95
2900	1343	1.72	1371	1.80	1397	1.88	1424	1.95	1450	1.99	1475	2.02	1500	2.05	1526	2.08

## BLOWER DATA - BELT DRIVE - KCB074S4T - HORIZONTAL

BLOWER TABLE INCLUDES RESISTANCE FOR BASE UNIT ONLY WITH DRY INDOOR COIL AND AIR FILTERS IN PLACE.

FOR ALL UNITS ADD:

1 - Any factory installed options air resistance (economizer, wet coil, etc.) See page 36.

2 - Any field installed accessories air resistance (electric heat, duct resistance, diffuser, etc.) See page 36.

See page 36 for blower motors and drives.

Air Volume cfm	External Static - in. w.g.															
	0.10		0.20		0.30		0.40		0.50		0.60		0.70		0.80	
	RPM	BHP	RPM	BHP	RPM	BHP	RPM	BHP	RPM	BHP	RPM	BHP	RPM	BHP	RPM	BHP
1900	853	0.41	886	0.46	919	0.50	952	0.55	986	0.60	1021	0.64	1056	0.69	1091	0.73
2000	883	0.48	913	0.53	944	0.57	976	0.62	1009	0.67	1043	0.71	1078	0.76	1112	0.80
2100	906	0.56	936	0.60	967	0.65	999	0.70	1033	0.75	1067	0.79	1101	0.84	1135	0.88
2200	930	0.64	960	0.68	991	0.73	1024	0.78	1058	0.83	1092	0.88	1126	0.92	1160	0.96
2300	954	0.72	985	0.77	1017	0.82	1051	0.87	1085	0.92	1119	0.96	1152	1.00	1186	1.04
2400	981	0.81	1013	0.86	1046	0.91	1079	0.96	1113	1.00	1146	1.05	1180	1.09	1213	1.13
2500	1010	0.91	1042	0.96	1075	1.00	1109	1.05	1142	1.09	1175	1.14	1207	1.18	1239	1.23
2600	1040	1.01	1073	1.05	1106	1.10	1139	1.14	1171	1.19	1203	1.23	1235	1.28	1266	1.33
2700	1072	1.10	1104	1.15	1137	1.20	1169	1.24	1201	1.29	1232	1.34	1263	1.40	1293	1.46
2800	1105	1.21	1137	1.25	1168	1.30	1200	1.35	1231	1.40	1261	1.46	1291	1.52	1321	1.59
2900	1138	1.32	1169	1.37	1200	1.42	1231	1.47	1261	1.53	1291	1.60	1321	1.66	1350	1.73

Air Volume cfm	External Static - in. w.g.															
	0.90		1.00		1.10		1.20		1.30		1.40		1.50		1.60	
	RPM	BHP	RPM	BHP	RPM	BHP	RPM	BHP	RPM	BHP	RPM	BHP	RPM	BHP	RPM	BHP
1900	1126	0.77	1163	0.81	1200	0.85	1237	0.88	1273	0.92	1306	0.96	1339	1.00	1371	1.04
2000	1148	0.84	1183	0.88	1220	0.92	1257	0.96	1291	1.00	1323	1.04	1354	1.08	1385	1.12
2100	1170	0.92	1206	0.96	1242	1.00	1277	1.04	1310	1.08	1340	1.13	1371	1.17	1401	1.21
2200	1195	1.00	1230	1.04	1265	1.08	1299	1.13	1330	1.18	1359	1.23	1388	1.27	1418	1.31
2300	1220	1.08	1254	1.13	1288	1.17	1320	1.23	1350	1.28	1378	1.34	1406	1.38	1435	1.42
2400	1245	1.18	1278	1.22	1311	1.28	1341	1.33	1370	1.40	1397	1.45	1425	1.50	1454	1.54
2500	1271	1.28	1303	1.33	1334	1.39	1363	1.45	1391	1.52	1418	1.57	1446	1.62	1474	1.66
2600	1297	1.39	1328	1.45	1357	1.52	1385	1.58	1412	1.64	1439	1.70	1467	1.74	1495	1.78
2700	1323	1.52	1353	1.58	1382	1.65	1409	1.72	1435	1.77	1462	1.82	1490	1.86	1517	1.90
2800	1351	1.65	1380	1.72	1407	1.78	1434	1.85	1460	1.90	1486	1.95	1513	1.99	1541	2.02
2900	1379	1.79	1407	1.86	1434	1.92	1460	1.98	1485	2.04	1511	2.08	1538	2.12	1565	2.15



## BLOWER DATA

### BELT DRIVE KIT SPECIFICATIONS

Model No.	Motor HP		No. of Speeds	Drive Kits and RPM Range							
	Nominal	Maximum		A01	A02	A03	A04	A05	A06	A07	A08
036	1	1.15	1	673-1010	---	---	---	897-1346	---	---	---
048	1	1.15	1	---	745-1117	---	---	---	1071-1429	---	---
060	1	1.15	1	---	---	833-1250	---	---	---	1212-1548	---
	1.5	1.7	1	---	---	833-1250	---	---	---	---	---
	2	2.3	1	---	---	833-1250	---	---	---	1212-1548	---
074	1	1.15	1	---	---	---	968-1340	---	---	---	1193-1591
	2	2.3	2	---	---	---	968-1340	---	---	---	1193-1591

### OPTIONS / ACCESSORIES AIR RESISTANCE - in. w.g.

Air Volume cfm	Wet Indoor Coil			Reheat Coil		Gas Heat		Econo-mizer	Electric Heat	Filters		
	024-048	060	074	024-048	060, 074	Medium Input	High Input			MERV 8	MERV 13	MERV 16
800	0.01	0.01	0.01	0.00	0.00	0.02	0.02	0.04	0.01	0.04	0.05	0.04
1000	0.02	0.02	0.01	0.00	0.00	0.02	0.02	0.04	0.03	0.04	0.07	0.05
1200	0.03	0.04	0.02	0.01	0.00	0.02	0.02	0.04	0.06	0.04	0.07	0.05
1400	0.04	0.05	0.03	0.02	0.01	0.02	0.03	0.04	0.09	0.04	0.07	0.06
1600	0.05	0.06	0.04	0.03	0.02	0.03	0.04	0.04	0.12	0.04	0.07	0.08
1800	0.06	0.07	0.05	0.04	0.02	0.03	0.05	0.05	0.15	0.05	0.07	0.09
2000	0.08	0.09	0.06	0.04	0.03	0.04	0.06	0.05	0.18	0.05	0.08	0.10
2200	0.09	0.10	0.07	---	0.04	0.04	0.07	0.05	0.20	0.05	0.08	0.11
2400	0.10	0.12	0.08	---	0.04	0.05	0.08	0.05	0.22	0.05	0.08	0.12

### MINIMUM AIR VOLUME REQUIRED FOR ELECTRIC HEAT

Size	kW Size	Minimum CFM		
		Direct Drive	Belt Drive Downflow	Belt Drive Horizontal
024-060	5	600	N/A	N/A
	7.5	600	1050	1200
	10	600	N/A	N/A
	15	1100	1200	1300
	22.5	1600	1500	1600
074	30	N/A	1900	2000

**TABLE 6  
DRIVE COMPONENT MANUFACTURER'S NUMBERS**

Drive No.	DRIVE COMPONENTS					
	MOTOR PULLEY		BLOWER PULLEY		BELTS	
	Browning No.	OEM Part No.	Browning No.	OEM Part No.	Browning No.	OEM Part No.
A01	1VP34 X 7/8	31K6901	AK54 X 1	100244-19	A40	100245-17
A02	1VP34 X 7/8	31K6901	AK49 X 1	100244-18	A39	100245-16
A03	1VP34 X 7/8	31K6901	AK44X 1	100244-16	A39	100245-16
A04	1VP40 X 7/8	79J0301	AK49 X 1	100244-18	A41	100245-18
A05	1VP34 X 7/8	31K6901	AK41 X 1	100244-15	A39	100245-16
A06	1VP44 X 7/8	P-8-1488	AK51 X 1	18L2201	A41	100245-18
A07	1VP50 X 7/8	P-8-2187	AK54 X 1	100244-19	AX43	73K8201
A08	1VP44 X 7/8	P-8-1488	AK46 X 1	100244-17	A40	100245-17
AA01	1VP34 X 7/8	31K6901	AK69 X 1	37L4701	A51	13H0101
AA02*	1VP40 X 7/8	79J0301	BK80H	100788-03	A53	100245-40
AA03	1VP40 X 7/8	79J0301	AK59 X 1	31K6801	A50	100245-29
AA04	1VP44 X 7/8	P-8-1488	AK59 X 1	31K6801	A51	13H0101

\*Split bushing supplier no.: H1; OEM no. 10073-04

### Cooling Start-Up

#### A-Operation

- 1 - Initiate first and second stage cooling demands according to instructions provided with thermostat. See TABLE 7 for operation.

**NOTE** - KG/KC 074 units are equipped with two-stage compressors.

**TABLE 7  
COOLING OPERATION**

T*Stat Demand	Energized	
<b>024-060 No Economizer or Outdoor Air Unsuitable</b>		
Y1	Compressor	Condenser Fan
Y2	Compressor	Condenser Fan
<b>024-060 Unit Equipped with an Economizer</b>		
Y1	Economizer	N/A
Y2	Economizer + Compressor	Condenser Fan
<b>074 No Economizer or Outdoor Air Unsuitable</b>		
Y1	Compressor Low Speed*	Condenser Fan
Y2	Compressor High Speed**	Condenser Fan
<b>074 Unit Equipped with Economizer</b>		
Y1	Economizer	N/A
Y2	Economizer + Compressor Low Speed*	Condenser Fan

\*67% of full capacity

\*\*100% of full capacity

- 2 - Units contain one refrigerant circuit or stage.
- 3 - Unit is charged with R-410A refrigerant. See unit rating plate for correct amount of charge.
- 4 - Refer to Refrigerant Charge and Check section for proper method to check refrigerant charge.

#### B-Three Phase Scroll Compressor Voltage Phasing

Three phase scroll compressors must be phased sequentially to ensure correct compressor and blower rotation and operation. Compressor and blower are wired in phase at the factory. Power wires are color-coded as follows: line 1-red, line 2-yellow, line 3-blue.

- 1 - Observe suction and discharge pressures and blower rotation on unit start-up.
- 2 - Suction pressure must drop, discharge pressure must rise and blower rotation must match rotation marking.

If pressure differential is not observed or blower rotation is not correct:

- 3 - Disconnect all remote electrical power supplies.

Discharge and suction pressures should operate at their normal star-up ranges.

- 4 - Reverse and two field-installed wires connected to the line side of K1 contactor. Do not reverse wires at blower contactor.
- 5 - Make sure the connections are tight.

**C-Refrigerant Charge and Check - All-Aluminum Coil**

**WARNING - Do not exceed nameplate charge under any condition.**

This unit is factory charged and should require no further adjustment. If the system requires additional refrigerant, reclaim the charge, evacuate the system, and add required nameplate charge.

**NOTE - System charging is not recommended below 60°F (15°C). In temperatures below 60°F (15°C), the charge must be weighed into the system.**

If weighing facilities are not available, or to check the charge, use the following procedure:

**IMPORTANT - Charge unit in standard cooling mode high compressor stage only.**

- 1 - Make sure outdoor coil is clean. Attach gauge manifolds and operate unit at full CFM in cooling mode with economizer disabled until system stabilizes (approximately thirty-five minutes). Make sure all outdoor air dampers are closed.
- 2 - Compare the normal operating pressures (see TABLE 8 through TABLE 13) to the pressures obtained from the gauges. Check unit components if there are any significant differences.
- 3 - Measure the outdoor ambient temperature and the suction pressure. Refer to the appropriate circuit charging curve to determine a target liquid temperature.

**NOTE - Pressures are listed for sea level applications.**

- 4 - Use the same thermometer to accurately measure the liquid temperature (in the outdoor section).
  - If measured liquid temperature is higher than the target liquid temperature, add refrigerant to system.
  - If measured liquid temperature is lower than the target liquid temperature, recover some refrigerant from the system.
- 5 - Add or remove charge in increments. Allow the system to stabilize each time refrigerant is added or removed.
- 6 - Continue the process until measured liquid temperature agrees with the target liquid temperature. Do not go below the target liquid temperature when adjusting charge. Note that suction pressure can change as charge is adjusted.
- 7 - Example KG/KC 024: At 95°F outdoor ambient and a measured suction pressure of 130psig, the target liquid temperature is 92°F. For a measured liquid temperature of 106°F, add charge in increments until measured liquid temperature agrees with the target liquid temperature.

**TABLE 8 581185-01  
ID & OD All-Aluminum Coils**

<b>KGB/KCB024 Normal Operating Pressures</b>											
Outdoor Coil Entering Air Temperature											
65°F		75°F		85°F		95°F		105°F		115°F	
Suct (psig)	Disc (psig)	Suct (psig)	Disc (psig)	Suct (psig)	Disc (psig)	Suct (psig)	Disc (psig)	Suct (psig)	Disc (psig)	Suct (psig)	Disc (psig)
115	225	118	262	121	306	124	358	126	417	128	484
125	226	128	262	131	306	133	357	135	416	137	483
145	231	149	266	151	308	154	359	156	416	158	482
168	239	171	272	174	314	176	363	179	419	181	484

**TABLE 9 581186-01  
ID & OD All-Aluminum Coils**

<b>KGB/KCB030 Normal Operating Pressures</b>											
Outdoor Coil Entering Air Temperature											
65°F		75°F		85°F		95°F		105°F		115°F	
Suct (psig)	Disc (psig)	Suct (psig)	Disc (psig)	Suct (psig)	Disc (psig)	Suct (psig)	Disc (psig)	Suct (psig)	Disc (psig)	Suct (psig)	Disc (psig)
119	229	121	267	123	309	125	356	126	408	127	464
126	232	129	270	131	313	134	360	136	412	137	468
141	239	145	277	149	320	153	368	156	421	159	478
157	247	163	286	168	329	173	378	178	431	182	488

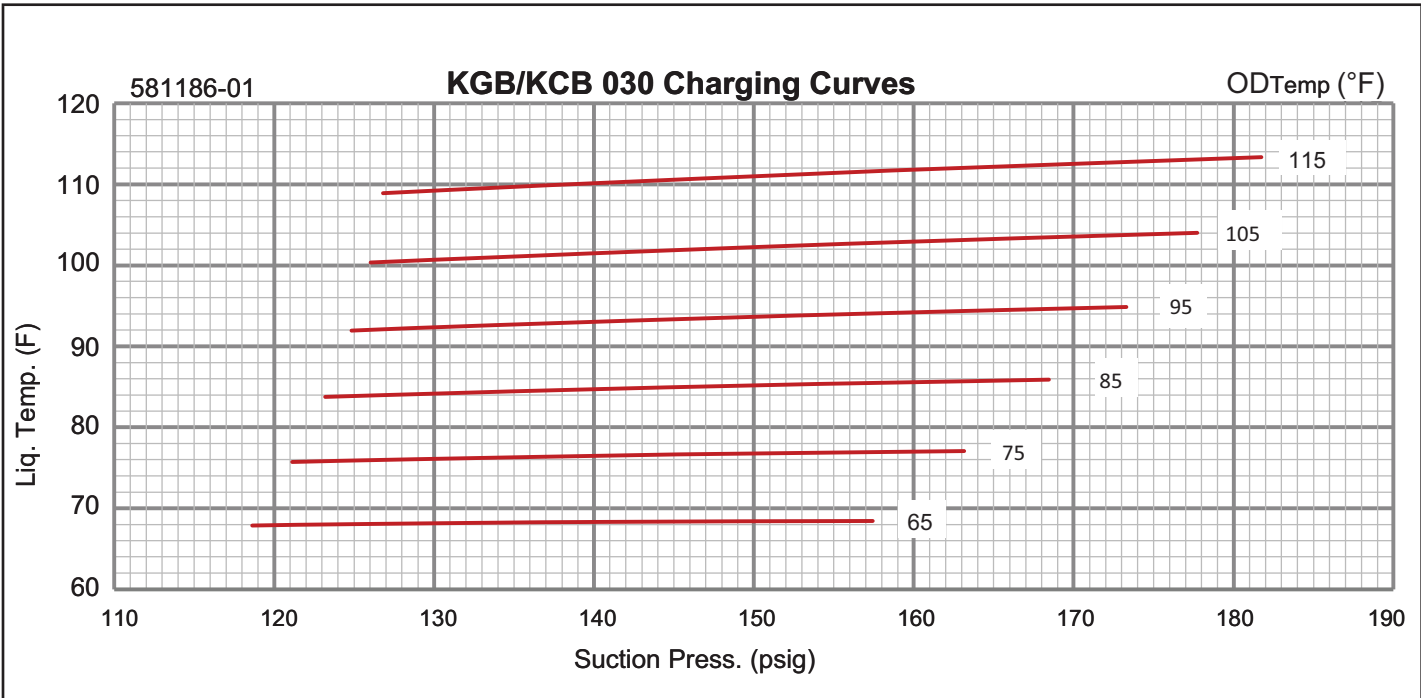
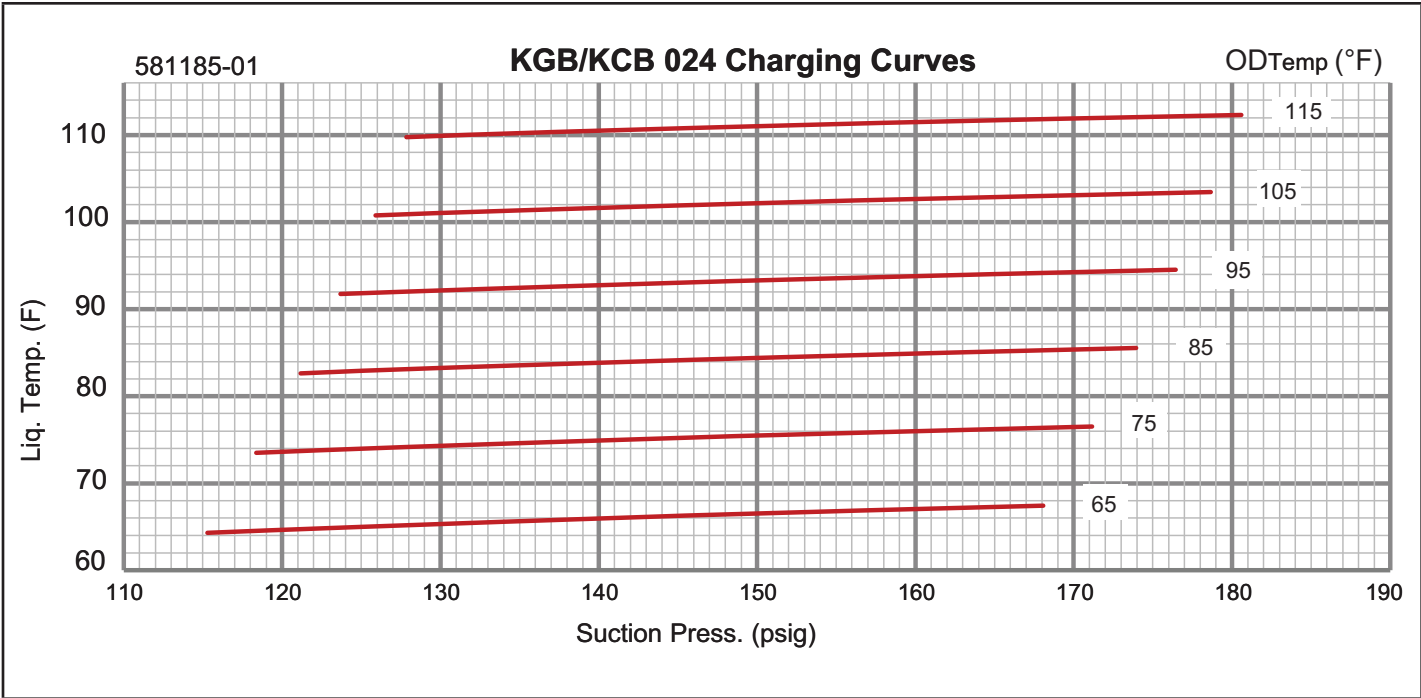

**TABLE 10 581187-01  
ID & OD All-Aluminum Coils**

<b>KGB/KCB036 Normal Operating Pressures</b>											
Outdoor Coil Entering Air Temperature											
65°F		75°F		85°F		95°F		105°F		115°F	
Suct (psig)	Disc (psig)	Suct (psig)	Disc (psig)	Suct (psig)	Disc (psig)	Suct (psig)	Disc (psig)	Suct (psig)	Disc (psig)	Suct (psig)	Disc (psig)
120	240	121	278	123	321	125	368	127	420	129	477
129	242	131	280	133	323	135	371	137	423	139	480
149	247	151	286	153	329	155	377	158	430	160	487
171	254	173	293	175	337	178	385	180	439	183	497

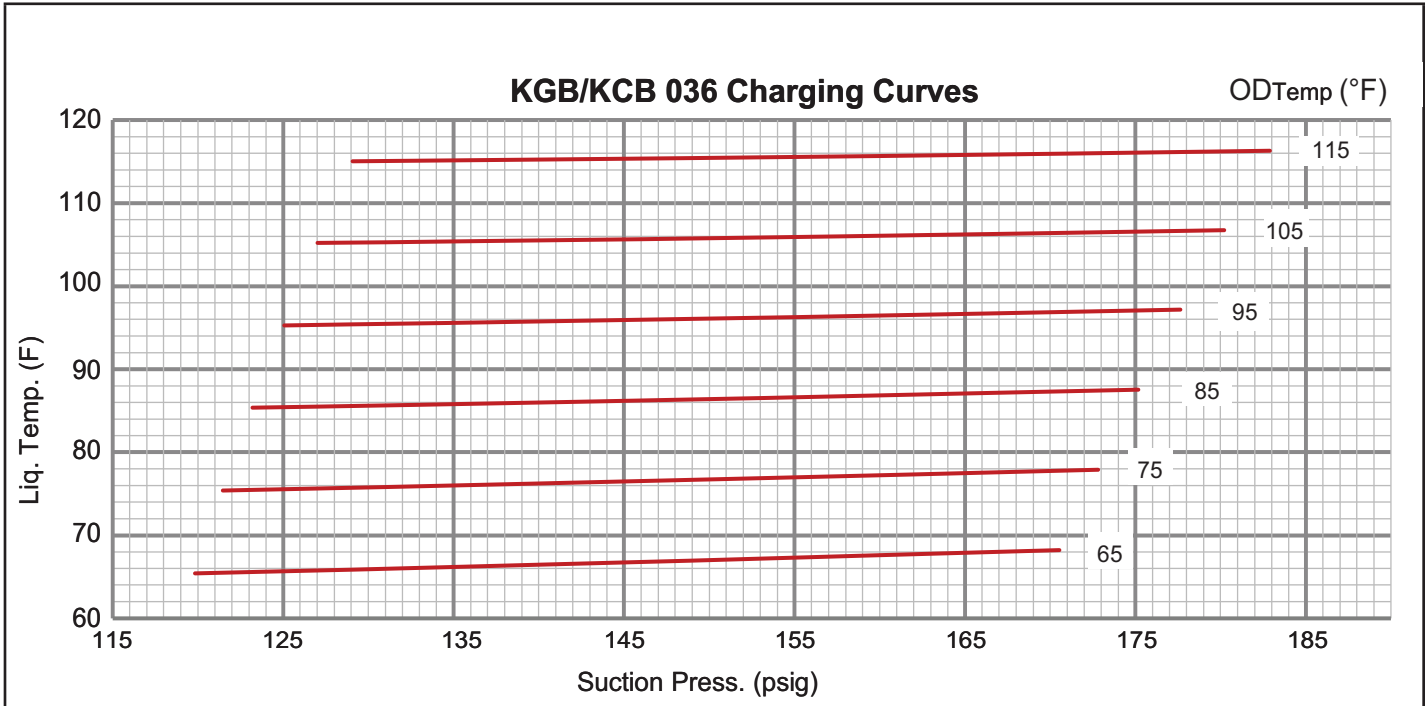

**TABLE 11 581188-01  
ID & OD All-Aluminum Coils**

<b>KGB/KCB048 Normal Operating Pressures</b>											
Outdoor Coil Entering Air Temperature											
65°F		75°F		85°F		95°F		105°F		115°F	
Suct (psig)	Disc (psig)	Suct (psig)	Disc (psig)	Suct (psig)	Disc (psig)	Suct (psig)	Disc (psig)	Suct (psig)	Disc (psig)	Suct (psig)	Disc (psig)
118	251	119	288	121	332	122	380	123	434	124	493
126	254	128	291	130	334	131	383	133	437	134	496
145	261	147	299	150	342	152	391	153	445	155	504
166	272	169	310	172	353	174	401	177	455	179	514

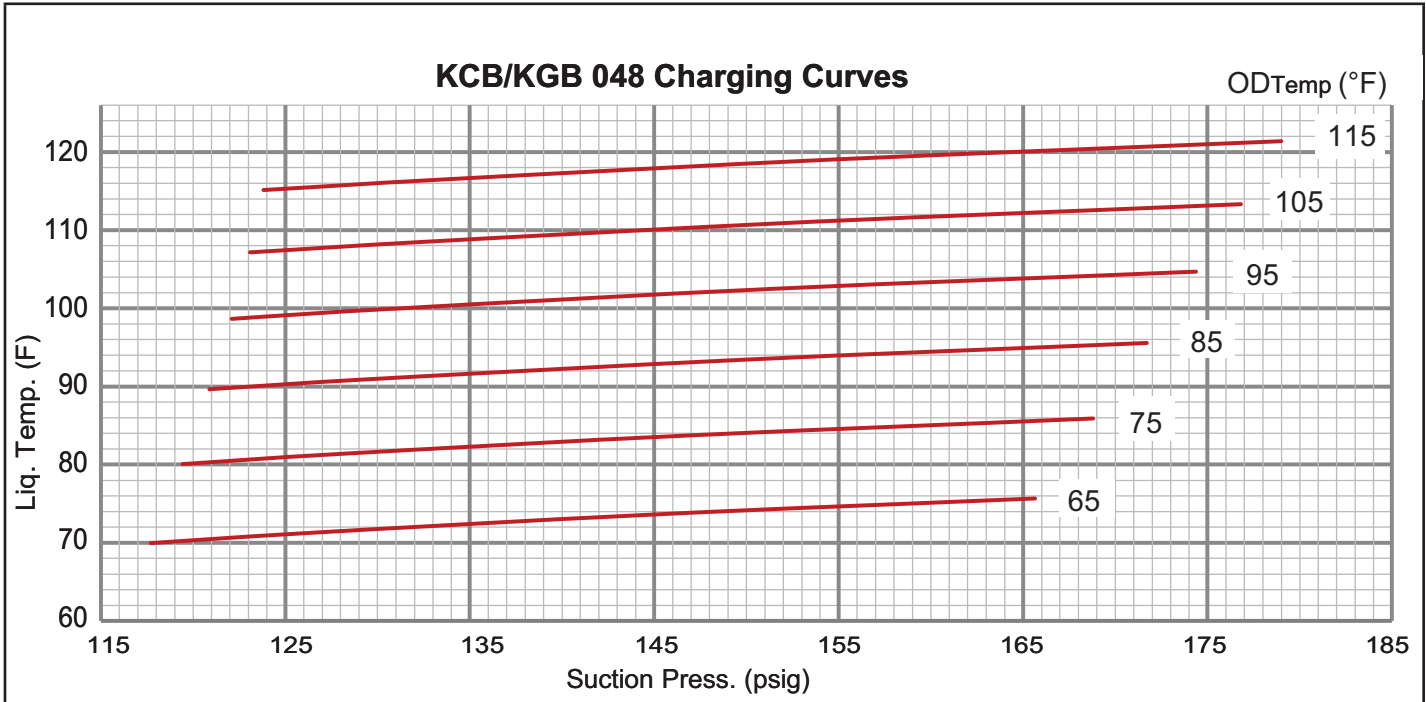



**TABLE 12 581183-01  
ID & OD All-Aluminum Coils**

<b>KGB/KCB 060 Normal Operating Pressures</b>											
Outdoor Coil Entering Air Temperature											
65°F		75°F		85°F		95°F		105°F		115°F	
Suct (psig)	Disc (psig)	Suct (psig)	Disc (psig)	Suct (psig)	Disc (psig)	Suct (psig)	Disc (psig)	Suct (psig)	Disc (psig)	Suct (psig)	Disc (psig)
114	244	116	281	118	324	120	372	121	423	124	483
123	248	125	285	127	328	129	376	131	427	133	487
143	258	145	294	148	337	150	385	152	436	154	497
158	269	164	304	169	348	172	397	174	446	178	506

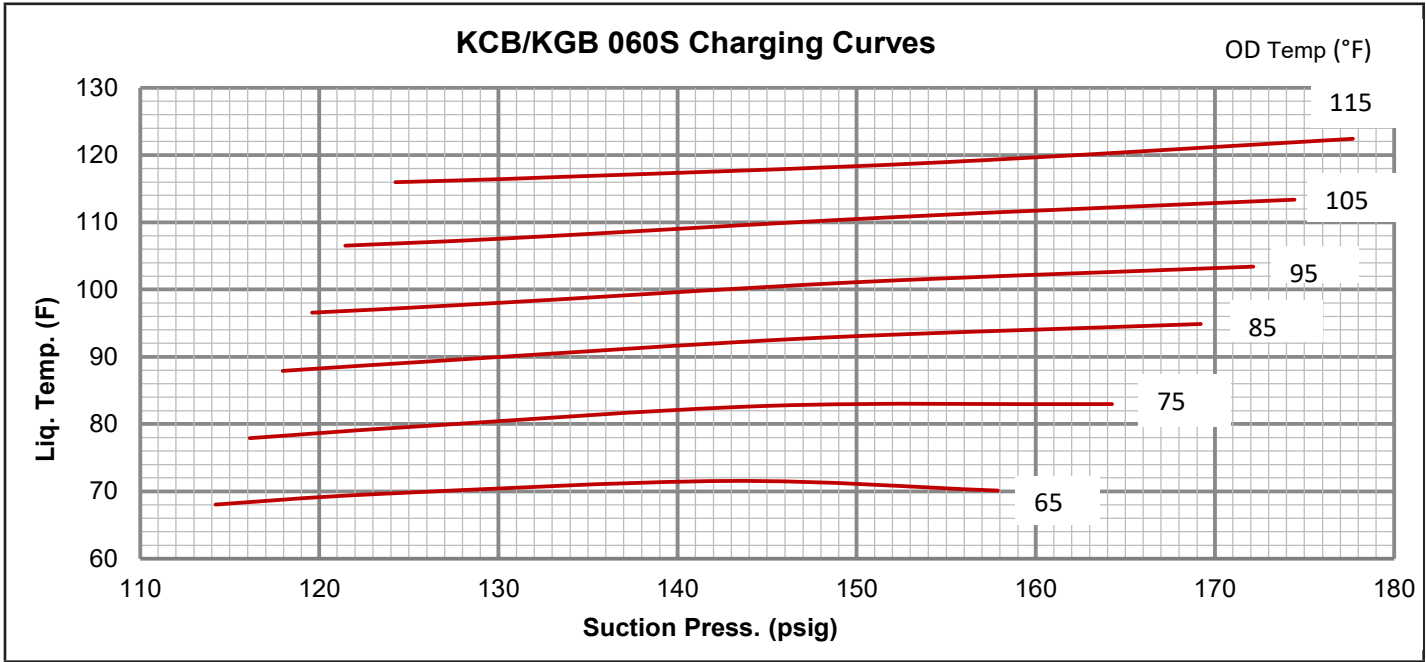

**TABLE 13 581184-01  
ID & OD All-Aluminum Coils**

<b>KGB/KCB 074S Normal Operating Pressures</b>											
Outdoor Coil Entering Air Temperature											
65°F		75°F		85°F		95°F		105°F		115°F	
Suct (psig)	Disc (psig)	Suct (psig)	Disc (psig)	Suct (psig)	Disc (psig)	Suct (psig)	Disc (psig)	Suct (psig)	Disc (psig)	Suct (psig)	Disc (psig)
111	254	113	292	114	337	116	386	117	441	118	502
118	259	121	297	123	341	125	390	127	445	129	506
133	271	137	309	141	352	144	401	148	456	150	516
149	287	154	324	159	367	164	416	169	470	173	530

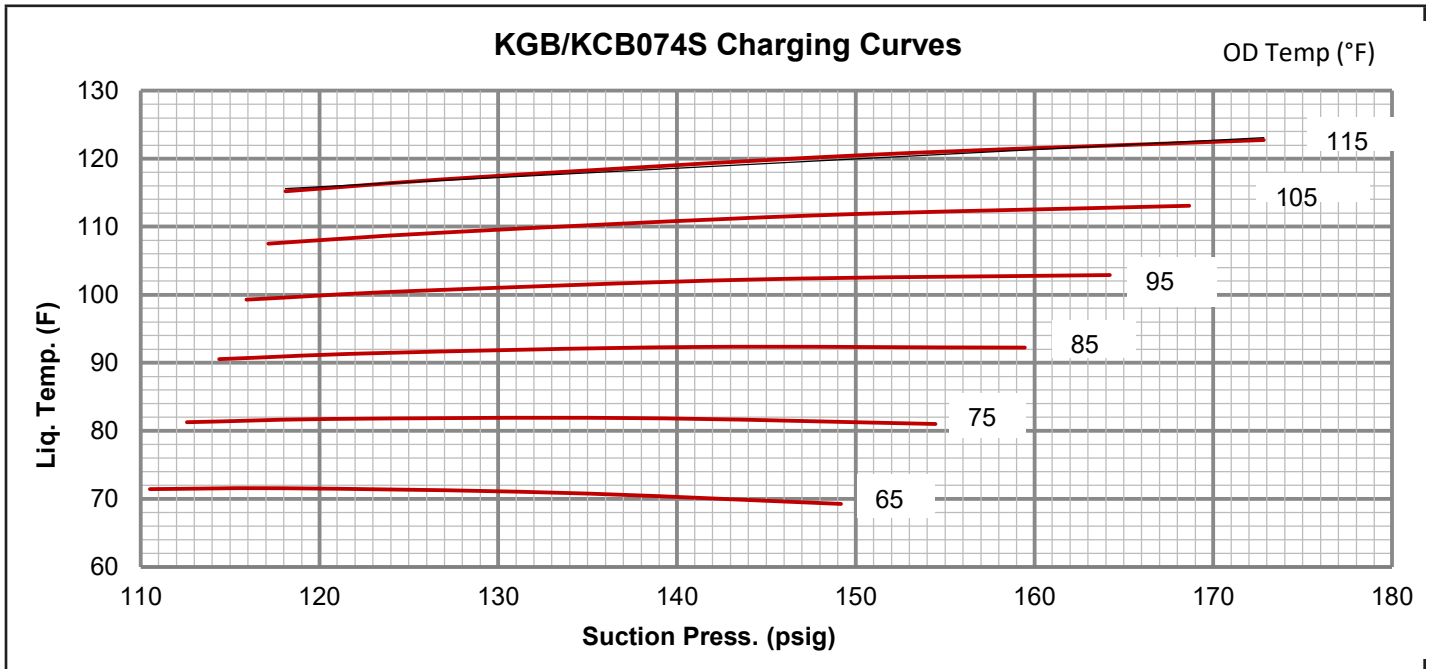

## D-Refrigerant Charge and Check - Fin/Tube Coil

KG/KC 024S, 030S, 036S, 048S, 060S, 074S

**WARNING - Do not exceed nameplate charge under any condition.**

This unit is factory charged and should require no further adjustment. If the system requires additional refrigerant, reclaim the charge, evacuate the system, and add required nameplate charge.

**NOTE - System charging is not recommended below 60°F (15°C). In temperatures below 60°F (15°C), the charge must be weighed into the system.**

If weighing facilities are not available, or to check the charge, use the following procedure:

### IMPORTANT - Charge unit in standard cooling mode.

- 1 - Attach gauge manifolds and operate unit in cooling mode with economizer disabled until system stabilizes (approximately five minutes). Make sure outdoor air dampers are closed.
- 2 - Check each system separately with all stages operating.
- 3 - Use a thermometer to accurately measure the outdoor ambient temperature.
- 4 - Apply the outdoor temperature to TABLE 14 through TABLE 19 to determine normal operation pressures. Pressures are listed for sea level applications at 80°F dry bulb and 67°F wet bulb return air.
- 5 - Compare the normal operating pressures to the pressures obtained from the gauges. Minor variations in these pressures may be expected due to differences in installations. Significant differences could mean the system is not properly charged or that a problem exists with some component in the system. **Correct any system problems before proceeding.**
- 6 - If discharge pressure is high, remove refrigerant from the system. If discharge pressure is low, add refrigerant to the system.
  - Add or remove charge in increments.
  - Allow the system to stabilize each time refrigerant is added or removed.
- 7 - Use the following approach method along with the normal operating pressures to confirm readings.

**TABLE 14 580942-01**

**KGB/KCB024S Fin/Tube - W & W/O Reheat**

Outdoor Coil Entering Air Temp.	Discharge ± 10psig	Suction ± 5psig
65° F	213	140
75° F	248	142
85° F	285	144
95° F	328	145
105° F	377	146
115° F	431	148

**TABLE 15 580943-01**

**KGB/KCB030S Fin/Tube - W & W/O Reheat**

Outdoor Coil Entering Air Temp.	Discharge ± 10psig	Suction ± 5psig
65° F	222	145
75° F	255	147
85° F	295	148
95° F	341	149
105° F	389	151
115° F	443	153

**TABLE 16 580944-01**

**KGB/KCB036S Fin/Tube - W & W/O Reheat**

Outdoor Coil Entering Air Temp.	Discharge ± 10psig	Suction ± 5psig
65° F	234	135
75° F	269	140
85° F	310	144
95° F	355	145
105° F	404	148
115° F	458	152

**TABLE 17 580945-01**

**KGB/KCB048S Fin/Tube - W & W/O Reheat**

Outdoor Coil Entering Air Temp.	Discharge ± 10psig	Suction ± 5psig
65° F	252	130
75° F	290	135
85° F	332	138
95° F	378	141
105° F	427	143
115° F	484	146

**TABLE 18 580946-01**

**KGB/KCB060S Fin/Tube - W & W/O Reheat**

Outdoor Coil Entering Air Temp.	Discharge ± 10psig	Suction ± 5psig
65° F	244	138
75° F	280	140
85° F	322	142
95° F	367	143
105° F	417	144
115° F	472	148

**TABLE 19 580947-01**

**KGB/KCB074S Fin/Tube - W & W/O Reheat**

Outdoor Coil Entering Air Temp.	Discharge ± 10psig	Suction ± 5psig
65° F	267	140
75° F	301	142
85° F	349	144
95° F	397	145
105° F	448	146
115° F	504	148

## Charge Verification - Approach Method

### (Fin/Tube Coil Continued)

- 1 - Using the same thermometer, compare liquid temperature to outdoor ambient temperature. Approach Temperature = Liquid Temperature (at condenser outlet) minus ambient temperature.
- 2 - Approach temperature should match values in TABLE 20. An approach temperature greater than value shown indicates an undercharge. An approach temperature less than value shown indicates an overcharge.
- 3 - The approach method is not valid for grossly over or undercharged systems. Use TABLE 14 through TABLE 19 as a guide for typical operating pressures.

**TABLE 20**  
**APPROACH TEMPERATURE - Fin/Tube - TXV**

KG/KC Unit	Liquid Temp. minus Ambient Temp.
024S, 030S, 036S	1°F + 1 (0.6°C + 0.5)
048S	2°F + 1 (1.1°C + 0.5)
060S	3°F + 1 (1.7°C + 0.5)
074S	4°F + 1 (2.2°C + 0.5)

## Charge Verification - Subcooling Method - AHRI Testing

### (Fin/Tube Coil Continued)

- 1 - Attach gauge manifold to the liquid line. With the economizer disabled, operate the unit line **cooling mode (at high speed on 2-speed units)**.
- 2 - Use the liquid line pressure and a PT chart to determine the saturated liquid temperature.
- 3 - Measure the liquid line temperature at the condenser outlet. Subcooling Temperature = Liquid Saturated Temperature minus Liquid Temperature.
- 4 - The subcooling temperature should be as shown in FIGURE 24. A subcooling temperature greater than this value indicates an overcharge. A subcooling temperature less than this value indicates an undercharge.

**TABLE 21**  
**SUBCOOLING TEMPERATURE**

LGH/LCH Unit	Liquid Saturated Temp. Minus Liquid Temperature
024S	7°F + 1 (3.9°C + 0.5)
030S	8°F + 1 (4.4°C + 0.5)
036S, 060S	9.5°F + 1 (5.2°C + 0.5)
048S	11.5°F + 1 (6.3°C + 0.5)
074S	12.5°F + 1 (6.9°C + 0.5)

## E-Compressor Controls

See unit wiring diagram to determine which controls are used on each unit. Optional controls are identified on wiring diagrams by arrows at junction points.

- 1 - Freezestat (S49) - Switch de-energizes compressor when evaporator coil temperature falls below 29°F (-2°C) to prevent evaporator freeze-up. Switch resets when evaporator coil temperature reaches 58°F (15°C).
- 2 - High Pressure Switch (S4) - High pressure switches are SPST N.C. switches which open on a pressure rise. The switch is an auto-reset switch. S4 is wired in series with the compressor contactor coil and is located on the compressor discharge line. When discharge pressure rises to 640±10psig (4412±69kPa), indicating a problem with the system, the switch opens. The respective compressor is de-energized but the economizer can continue to operate. Auto-reset switches close at 475±20psig (3275±138kPa)
- 3 - Compressor High Temperature (S5) S5 is located on the top of the Interlink compressor and is wired in series with the high pressure switch S4.

## Gas Heat Start-Up (Gas Units)

FOR YOUR SAFETY, READ BEFORE LIGHTING

### ⚠️ WARNING



Electric shock hazard. Can cause injury or death. Do not use this unit if any part has been under water. Immediately call a qualified service technician to inspect the unit and to replace any part of the control system and any gas control which has been under water.

### ⚠️ WARNING



Danger of explosion. Can cause injury or product or property damage. If over heating occurs or if gas supply fails to shut off, shut off the manual gas valve to the appliance before shutting off electrical supply.

### ⚠️ WARNING

#### SMOKE POTENTIAL

The heat exchanger in this unit could be a source of smoke on initial firing. Take precautions with respect to building occupants and property. Vent initial supply air outside when possible.

### ⚠️ WARNING



Electric shock hazard. Can cause injury or death. Before attempting to perform any service or maintenance, turn the electrical power to unit OFF at disconnect switch(es). Unit may have multiple power supplies.

BEFORE LIGHTING smell all around the appliance area for gas. Be sure to smell next to the floor because some gas is heavier than air and will settle on the floor.

The gas valve may be equipped with either a gas control lever or gas control knob. Use only your hand to push the lever or turn the gas control knob. Never use tools. If the lever will not move or the knob will not push in or turn by hand, do not try to repair it. Call a qualified service technician. Force or attempted repair may result in a fire or explosion.

### ⚠️ WARNING



Danger of explosion. Can cause injury or death. Do not attempt to light manually. Unit has a direct spark ignition system.

This unit is equipped with an automatic spark ignition system. There is no pilot. In case of a safety shutdown, move thermostat switch to **OFF** and return the thermostat switch to **HEAT** to reset ignition control.

#### A-Pacing Unit in Operation

### ⚠️ WARNING



Danger of explosion and fire. Can cause injury or product or property damage. You must follow these instructions exactly.

#### Gas Valve Operation (figure 25 and 26)

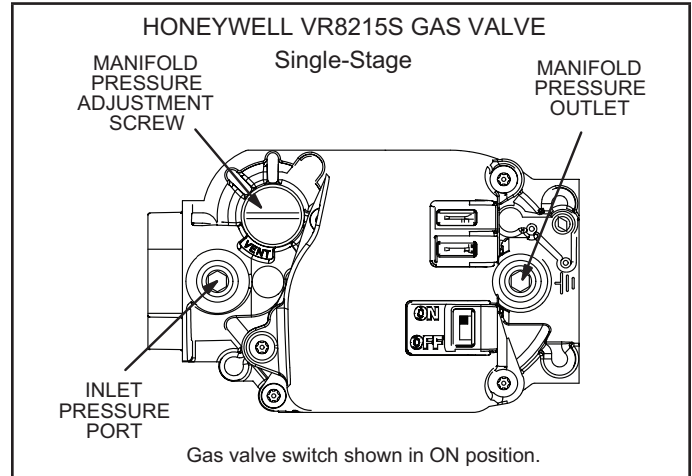

FIGURE 25

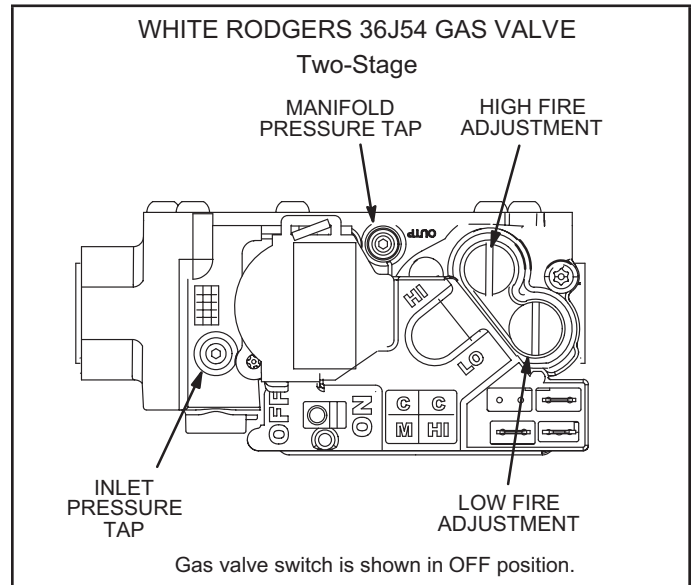

FIGURE 26

- 1 - Set thermostat to lowest setting.
- 2 - Turn off all electrical power to appliance.
- 3 - This appliance is equipped with an ignition device with automatically lights the burner. Do **not** try to light the burner by hand.
- 4 - Open the access control panel.
- 5 - Move gas valve switch to **OFF**. See FIGURE 25 or FIGURE 26.
- 6 - Wait five (5) minutes to clear out any gas. If you then smell gas, **STOP!** Immediately call your gas supplier from a neighbor's phone. Follow the gas supplier's instructions. If you do not smell gas, go to the next step.
- 7 - Move gas valve switch to **ON**. See FIGURE 25 or FIGURE 26.
- 8 - Close the control access panel.
- 9 - Turn on all electrical power to appliance.
- 10 - Set thermostat to desired setting.

**NOTE** - When unit is initially installed, steps 1 through 9 may need to be repeated to purge air from gas line.

- 11 - The ignition sequence will start.
- 12 - If the furnace does not light the first time (gas line not fully purged), it will attempt up to two more ignitions before locking out.
- 13 - If lockout occurs, repeat steps 1 through 10.
- 14 - If the appliance will not operate, follow the instructions "Turning Off Gas to Appliance" and call your service technician or gas supplier.

#### Turning Off Gas to Unit

- 1 - If using an electromechanical thermostat, set to the lowest setting.
- 2 - Before performing any service, turn off all electrical power to the appliance.
- 3 - Open or remove the heat section access panel.
- 4 - Turn gas valve switch to **OFF**.
- 5 - Close or replace the heat section access panel.

 <b>WARNING</b>
 <b>Danger of explosion. Can cause injury or death. Do not attempt to light manually. Unit has a direct spark ignition system.</b>

### Heating Operation and Adjustments

*(Gas Units)*

#### A-Heating Sequence of Operation

- 1 - On a heating demand the combustion air inducer starts immediately.
- 2 - Combustion air pressure switch proves inducer operation. After a 30-second pre-purge, power is allowed to ignition control. Switch is factory set and requires no adjustment.
- 3 - Spark ignitor energizes and gas valve solenoid opens.

- 4 - Spark ignites gas, ignition sensor proves the flame and combustion continues.
- 5 - If flame is not detected after first ignition trial, ignition control will repeat steps 3 and 4 two more times before locking out the gas valve.
- 6 - For troublesome purposes, an ignition attempt after lock may be re-established manually. Move thermostat to **OFF** and return thermostat switch to **HEAT** position.

#### B-Ignition Control Diagnostic LED's

**TABLE 22  
IGNITION CONTROL HEARTBEAT LED STATUS**

LED Flashes	Indicates
Slow	Normal operation. No call for heat.
Fast	Normal operation. Call for heat.
Steady Off	Internal control fault OR no power to control OR Gas Valve Relay Fault.
Steady On	Control internal failure.
2	Lockout. Failed to detect or sustain flame.
3	Prove switch open or closed or rollout switch open.
4	Limit switch is open and/or high limit has opened three times.
5	Flame sensed but gas valve solenoid not energized.

#### C-Limit Controls

Limit controls are factory-set and are not adjustable. The primary limit is located to the right of the combustion air inducer. See FIGURE 32.

If the primary limit trips three times in the same heating cycle, heating operation will de-energize. Heating will automatically restart after one hour if a heating demand is present. To initiate heating during the one hour timed-off interval, reset the thermostat.

#### D-Heating Adjustment

Main burners are factory-set and do not require adjustment.

The following manifold pressures are listed on the gas valve.

- Natural Gas Units - Low Fire - 2.0-inch w.c.
- Natural Gas Units - High Fire - 3.5-inch w.c.
- LP Gas Units - Low Fire 5.9-inch w.c.
- LP Gas Units - High Fire - 10.5-inch w.c.

### Electric Heat Start-Up (KC Units)

Optional electric heat will stage on and cycle with thermostat demand. See electric heat wiring diagram on unit for sequence of operation.



## Hot Gas Reheat Start-Up and Operation

### General

Hot gas reheat units provide a dehumidifying mode of operation. These units contain a reheat coil adjacent to and downstream of the evaporator coil. Reheat coil solenoid valve, L14, routes hot discharge gas from the compressor to the reheat coil. Return air pulled across the evaporator coil is cooled and dehumidified; the reheat coil adds heat to supply air. See FIGURE 27 for reheat and refrigerant routing.

### L14 Reheat Coil Solenoid Valve

When room conditions close the dehumidistat switch, L14 reheat valve is energized and refrigerant is routed to the reheat coil.

### Reheat Setpoint

Reheat is factory-set to energize when indoor relative humidity rises above setpoint. Reheat will terminate when the indoor relative humidity falls below or the digital output de-energizes. Turn the knob on the dehumidistat to adjust the setpoint.

### Check-Out

Test hot gas reheat operation using the following procedure:

- 1 - Make sure reheat is wired as shown in wiring section.
- 2 - Initiate a dehumidification demand by adjusting dehumidistat setpoint knob **BELOW** indoor relative humidity. The blower and compressor 1 should be operation. On 074 two-speed units, the blower and/or compressor should be operating in high speed.
- 3 - End a dehumidification demand by adjusting setpoint knob **ABOVE** indoor relative humidity. The blower and compressor should de-energize.

### Default Reheat Operation

See TABLE 23

**TABLE 23**  
**Reheat Operation - Default**

T'Stat and/or Humidity Demand	Operation		
	024-060S	074S4B	074S4T
<b>Reheat Only</b>	Compressor <b>ON</b> Reheat Valve <b>ON</b> Blower <b>ON</b>	Compressor <b>HIGH</b> Reheat Valve <b>ON</b> Blower <b>ON</b>	Compressor <b>HIGH</b> Reheat Valve <b>ON</b> Blower <b>HIGH</b>
<b>Reheat &amp; Y1*</b>	Compressor <b>ON</b> Reheat Valve <b>ON</b> Blower <b>ON</b>	Compressor <b>HIGH</b> Reheat Valve <b>ON</b> Blower <b>ON</b>	Compressor <b>HIGH</b> Reheat Valve <b>ON</b> Blower <b>HIGH</b>
<b>Reheat, Y1, &amp; Y2**</b>	Compressor <b>ON</b> Reheat Valve <b>OFF</b> Blower <b>ON</b>	Compressor <b>HIGH</b> Reheat Valve <b>OFF</b> Blower <b>ON</b>	Compressor <b>HIGH</b> Reheat Valve <b>OFF</b> Blower <b>HIGH</b>

\* If there is no reheat demand and outdoor air is suitable, free cooling will operate.

\*\* If there is no reheat demand and outdoor air is suitable, free cooling and compressor 1 will operate.

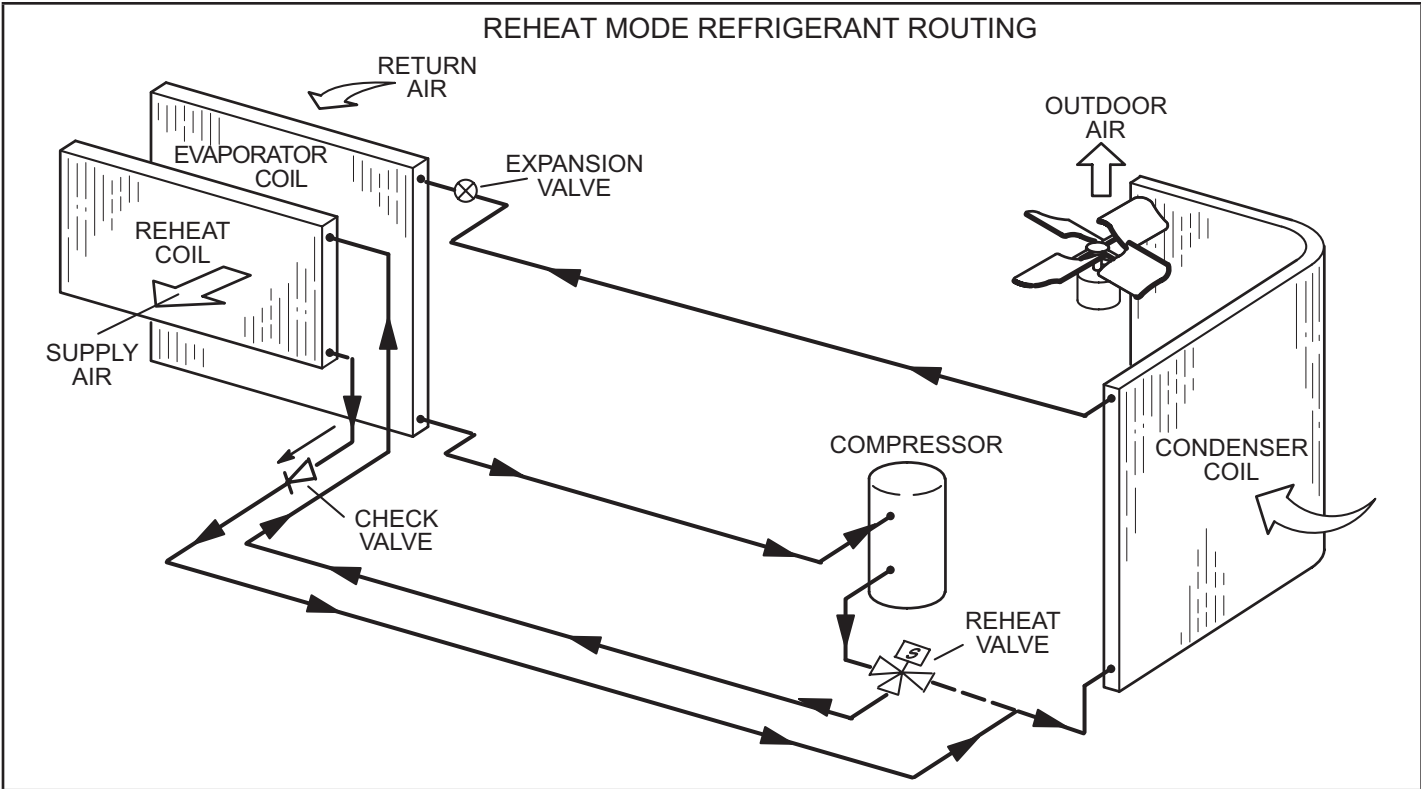

**FIGURE 27**

## Service

The unit should be inspected once a year by a qualified service technician.

## ⚠ CAUTION

Label all wires prior to disconnection when servicing controls. Wiring errors can cause improper and dangerous operation. Verify proper operation after servicing.

### A-Filters

Units are equipped with temporary filters which must be replaced prior to building occupation. See TABLE 24 for correct filter size. Refer to local codes or appropriate jurisdiction for approved filters.

## ⚠ WARNING

Units are shipped from the factory with temporary filters. Replace filters before building is occupied. Damage to unit could result if filters are not replaced with approved filters. Refer to appropriate codes.

Approved filters should be checked monthly and replaced when necessary. Take note of air flow direction marking on filter frame when reinstalling filters. See FIGURE 28.

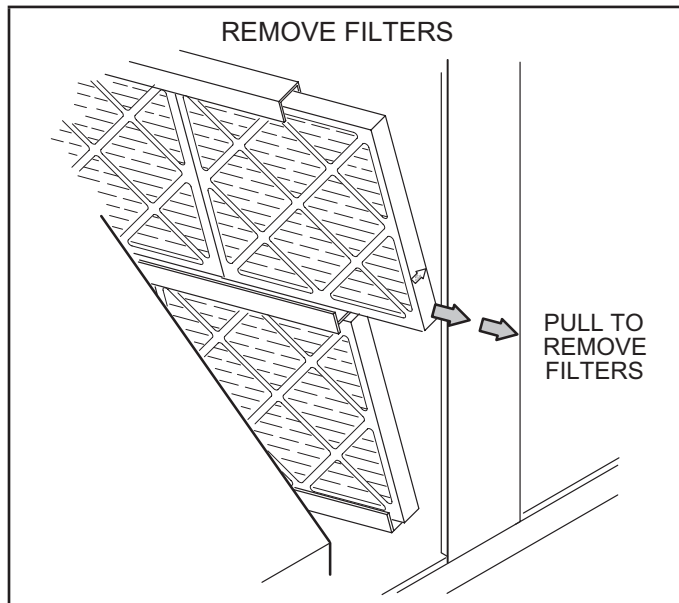

FIGURE 28

TABLE 24  
UNIT FILTERS

Unit	Qty.	Filter Size - in. (mm)
KGB/KCB024, 030, 036, 048	4	16 x 20 x 2 (406 x 508 x 51)
KGB/KCB060, 074	4	20 x 20 x 2 (508 x 508 x 51)

NOTE - Filters must be U.L.C. certified or equivalent for use in Canada.

### B-Lubrication

All motors are lubricated at the factory. No further lubrication is required.

### C-Burners (Gas Units)

Periodically examine burner flames for proper appearance during the heating season. Before each heating season examine the burners for any deposits or blockage which may have occurred.

Clean burners as follows:

- 1 - Turn off both electrical power and gas supply to unit.
- 2 - Remove blower access panel.
- 3 - Remove top burner box panel.
- 4 - Remove screws securing burners to burner support and lift the individual burners or the entire burner assembly from the orifices. See FIGURE 29. Clean as necessary.

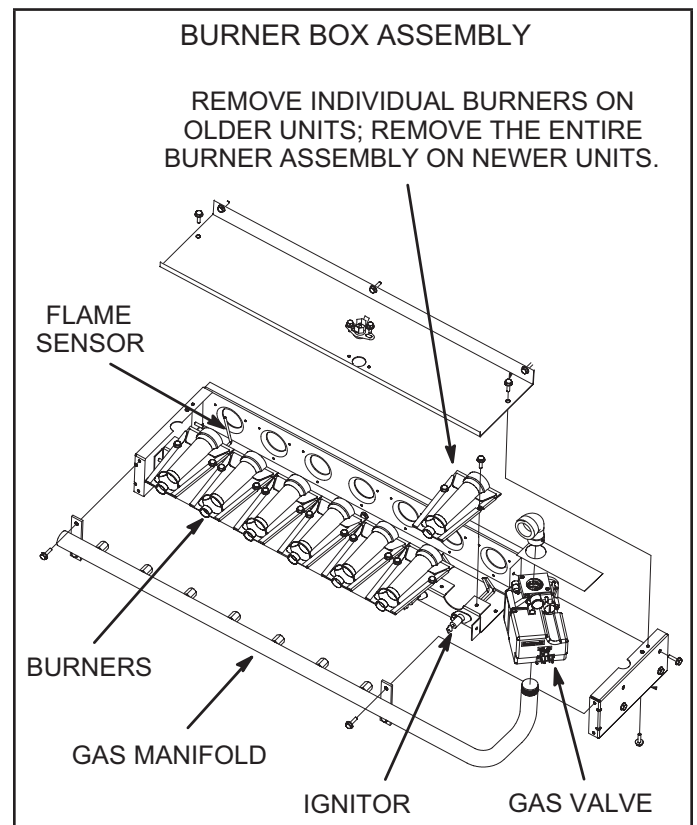
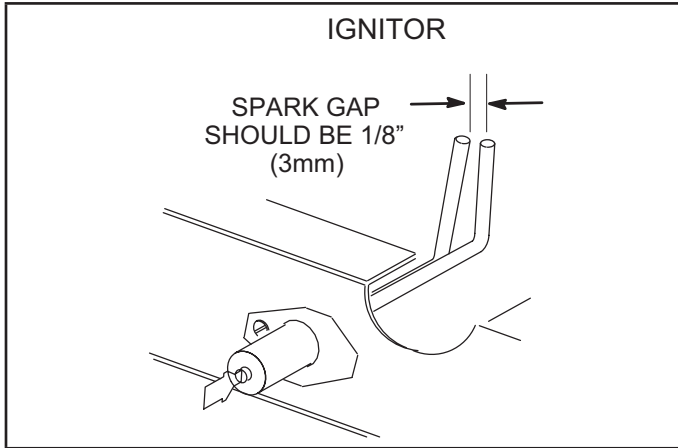

FIGURE 29

- 5 - Locate the igniter under the right burner. Check igniter spark gap with appropriately sized twist drills or feeler gauges. See FIGURE 30.



**FIGURE 30**

- 6 - Replace burners and screws securing burner. See FIGURE 31.

**⚠ WARNING**

**Danger of explosion. Can cause injury or death. Do not overtighten main burner mounting screws. Snug tighten only.**

- 7 - Replace access panel.
- 8 - Restore electrical power and gas supply. Follow lighting instructions attached to unit and use inspection port in access panel to check flame.

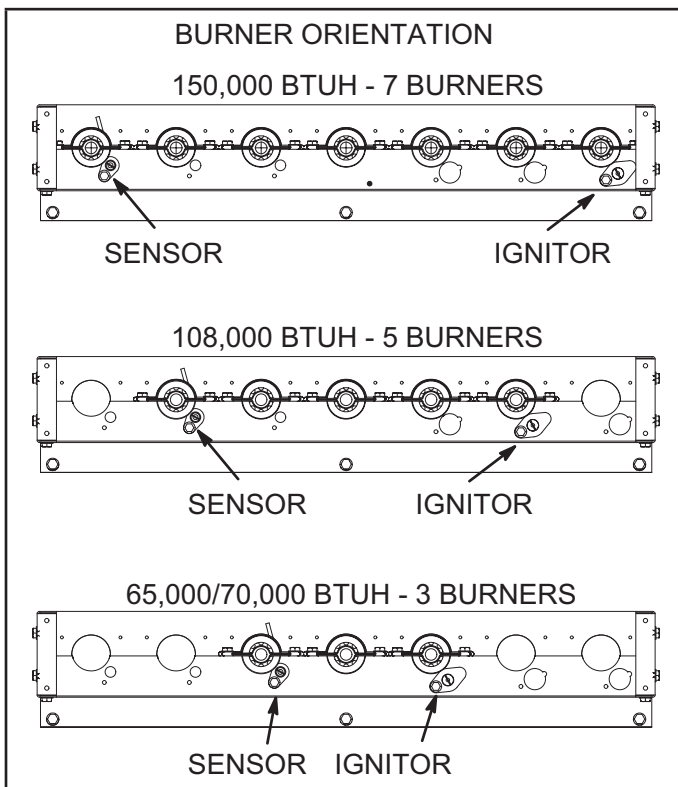

**FIGURE 31**

### D-Combustion Air Inducer (Gas Units)

A combustion air proving switch checks combustion air inducer operation before allowing power to the gas controller. Gas controller will not operate if inducer is obstructed.

Under normal operating conditions, the combustion air inducer wheel should be checked and cleaned prior to the heating season. However, it should be examined periodically during the heating season to establish an ideal cleaning schedule.

Clean combustion air inducer as follows:

- 1 - Shut off power supply and gas to unit.
- 2 - Remove the mullion on the right side of the heat section.
- 3 - Disconnect pressure switch air tubing from combustion air inducer port.
- 4 - Remove and retain screws securing combustion air inducer to flue box. Remove vent connector. See FIGURE 32.

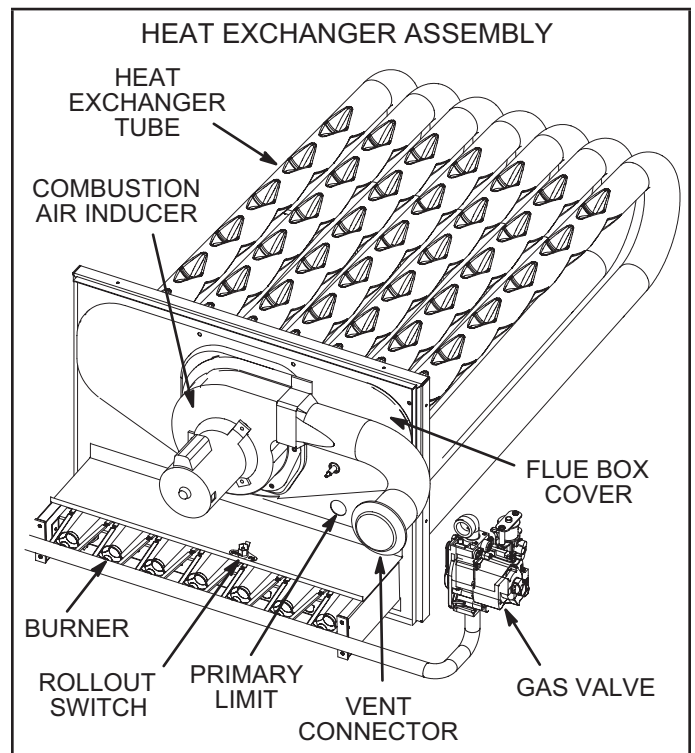

**FIGURE 32**

- 5 - Clean inducer wheel blades with a small brush and wipe off any dust from housing. Take care not to damage exposed fan blades. Clean accumulated dust from front of flue box cover.
- 6 - Return combustion air inducer motor and vent connector to original location and secure with retained screws. It is recommended that gaskets be replaced during reassembly.
- 7 - Replace mullion.
- 8 - Clean combustion air inlet louvers on blower access panel using a small brush.

### E-Flue Box (Gas Units)

Remove flue box cover only when necessary for equipment repair. Clean inside of flue box cover and heat exchanger tubes with a wire brush when flue box cover has to be removed. Install a new flue box cover gasket and replace cover. Make sure edges around flue box cover are tightly sealed.

### F-Evaporator Coil

Inspect and clean coil at beginning of each cooling season. Clean using mild detergent or commercial coil cleaner. Flush coil and condensate drain with water, taking care not to get insulation, filters, and return air ducts wet.

### G-Supply Air Blower Wheel

Annually inspect supply air blower wheel for accumulated dirt or dust. Turn off power before attempting to remove access panel or to clean blower wheel.

### H-Condenser Coil

Clean condenser coil annually with water and inspect monthly during the cooling season.

Clean the all-aluminum coil by spraying the coil steadily and uniformly from top to bottom. Do not exceed 900 psi or a 45° angle; nozzle must be at least 12 inches from the coil face. Take care not to fracture the braze between the fins and refrigerant tubes. Reduce pressure and work cautiously to prevent damage.

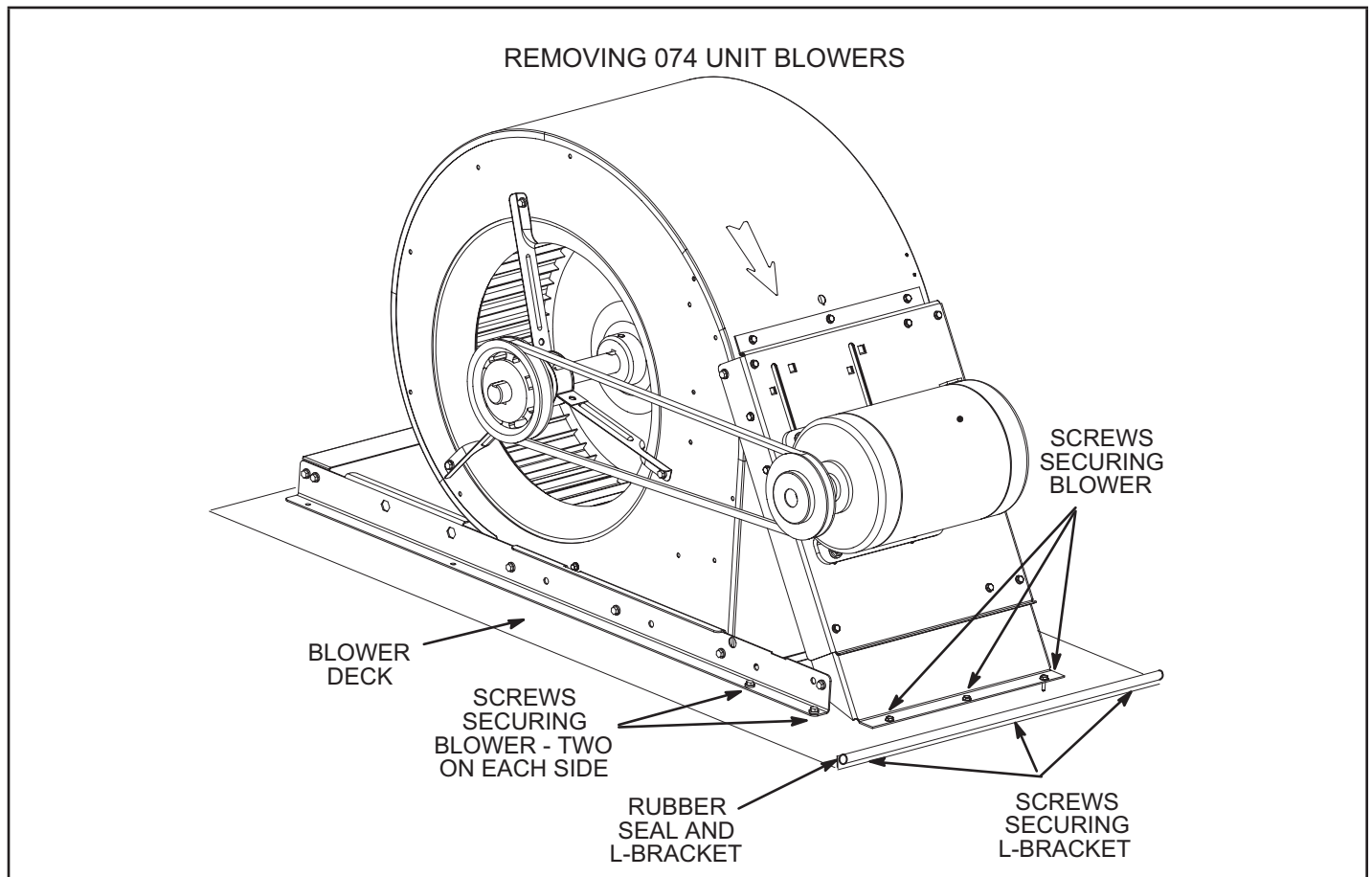

FIGURE 33

## START-UP REPORT

Job Name: \_\_\_\_\_  
 Store No. \_\_\_\_\_ Start-Up Date: \_\_\_\_\_  
 Address: \_\_\_\_\_  
 City: \_\_\_\_\_ State: \_\_\_\_\_  
 Start-Up Contractor: \_\_\_\_\_  
 Technician: \_\_\_\_\_  
 Model No.: \_\_\_\_\_  
 Serial No.: \_\_\_\_\_  
 RTU No.: \_\_\_\_\_ Catalog No.: \_\_\_\_\_

Inspections and Checks			
Damage?	Yes	No	R22 <input type="checkbox"/> R410A <input type="checkbox"/>
If yes, reported to: _____			
Verify factory and field-installed accessories.			
Check electrical connections. Tighten if necessary.			
Supply voltage: L1-L2 _____ L1-L3 _____ L2-L3 _____			
If unit contains a 208-230/240 volt transformer:			
Check primary transformer tap <input type="checkbox"/>			
Transformer secondary voltage: _____			

Cooling Checks												
Compressor Rotation <input type="checkbox"/> Ambient Temp. _____ Return Air Temp. _____ Supply Air Temp. _____												
	Compressor Amps			Compressor Volts			Pressures		Condenser Fan Amps			CC Heater Amps
	L1	L2	L3	L1-L2	L1-L3	L2-L3	Disch.	Suct.	L1	L2	L3	L1
1												
2												
3												
4												

Blower Checks	
Pulley/Belt Alignment <input type="checkbox"/>	Blower Rotation <input type="checkbox"/>
Set Screws Tight <input type="checkbox"/>	Belt Tension <input type="checkbox"/>
Nameplate Amps: _____ Volts: _____	
Motor	Amps
	Volts
L1 _____	L1-L2 _____
L2 _____	L1-L3 _____
L3 _____	L2-L3 _____

Heating Checks - Electric							
Return Air Temp.: _____ Supply Air Temp.: _____							
Limits Operate: <input type="checkbox"/>							
	Amps						
	L1	L2	L3		L1	L2	L3
1				10			
2				11			
3				12			
4				13			
5				14			
6				15			
7				16			
8				17			
9				18			

Heating Checks - Gas		
Fuel type: Nat. <input type="checkbox"/> LP <input type="checkbox"/> Inlet Pressure: _____ in. w.c.		
Return Air Temp.: _____ Supply Air Temp.: _____		
Altitude: _____ Primary Limits Operate: <input type="checkbox"/>		
Gas Valve	Manifold Pressure	
	Low Fire	High Fire
GV1		
GV2		

Accessory Checks	
Power Exhaust Amps	
1 _____	2 _____ None <input type="checkbox"/>
Economizer Operation	
Min. Pos. <input type="checkbox"/>	Motor travel full open/close <input type="checkbox"/>

Control Type