

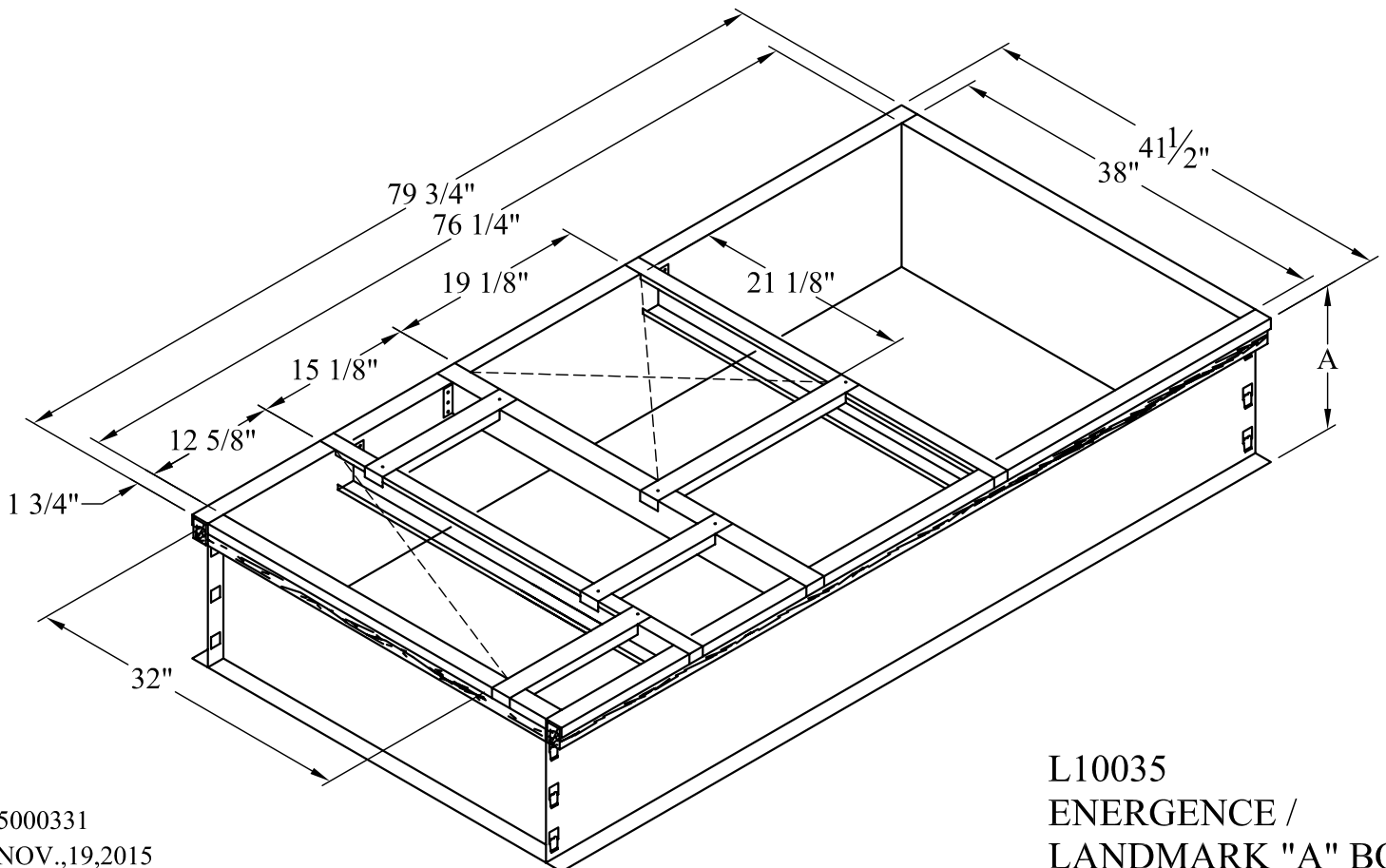

***HYBRID ROOF CURB INSTALLATION
TO SUIT
ENERGENCE/LANDMARK "A" BOX**

TYPICAL ASSEMBLY PARTS LIST (all heights)	
QTY	DESCRIPTION
2	CURB SIDES
2	CURB ENDS
7	DUCT BRACES
1	HARDWARE BAG
1	ASSEMBLY INSTRUCTION
4	NAILS
26	SCREWS (#8 x 1/2")

ASSEMBLY PARTS LIST			
HEIGHT A	NUTS (1/4")	BOLTS (1/4"x1/2")	FLAT WASHERS (1/4")
8"	8	8	8
14"	12	12	12
18"	12	12	12
24"	12	12	12



5000331
NOV.,19,2015

**L10035
ENERGENCE /
LANDMARK "A" BOX**



INSTALLATION INSTRUCTIONS

*HYBRID ROOF CURB

CURB VERIFICATION

PRIOR TO FRAME FINAL ASSEMBLY AND INSTALLATION, VERIFY THAT ALL THE DIMENSIONS AND MODEL NUMBER DESIGNATIONS MATCH THOSE SHOWN ON THE ENCLOSED DRAWING. NOTIFY THE FACTORY OF ANY DISCREPANCIES. THE MANUFACTURER WILL NOT ASSUME ANY LIABILITIES OR COSTS AS THE RESULT OF ANY OF THE PROCEDURES LISTED IN THIS INSTRUCTION NOT BEING FOLLOWED AS DIRECTED.

* US PATENTS 5188333, 5255887
CANADIAN PATENT 2073900
ADDITIONAL PATENTS PENDING

FRAME ASSEMBLY

- STEP #1 TAKE ONE END PIECE (LOCKING TABS) AND ONE SIDE PIECE (SLOTS), STAND BOTH PIECES VERTICALLY ON FLOOR OR ROOF.
- STEP #2 RAISE SLIGHTLY THE CORNER OF THE END PIECE (LOCKING TABS) AND MATE WITH SIDE PIECE (SLOTS), ENSURING THAT LOWER LOCKING TAB WITH LEADING EDGE IS THROUGH SLOT OPENING. REFER TO FIG.#1.
- STEP #3 PUSH DOWN ON TOP EDGE OF END PIECE. ENSURE THAT ALL 3 OF THE LOCKING TABS ARE FEEDING INTO EACH CORRESPONDING SLOT. ONCE BOTH PIECES ARE FLUSH THE PROCESS IS COMPLETE. REFER TO FIG.#2.
- STEP #4 DRIVE ONE SPIKE PROVIDED INTO WOOD NAILER STRIPS AT EACH CORNER. REFER TO FIG.#3.
- STEP #5 PLACE DUCT SUPPORT CHANNELS IN THE LOCATIONS NOTED ON THE ENCLOSED DRAWING, THESE CHANNELS ARE PROVIDED WITH PRE PUNCHED HOLES TO ASSIST IN THE FASTENING PROCESS, HOWEVER IT WILL BE NECESSARY TO FIELD MEASURE THE FINAL LOCATION OF ALL CHANNELS (AS PER THE ENCLOSED DRAWING) PRIOR TO FASTENING IN PLACE WITH SCREWS PROVIDED. (FIG.#6) CONTACT THE FACTORY IF ANY DISCREPANCIES ARE APPARENT PRIOR TO THE MANUFACTURE OF THE DUCT OR INSTALLATION OF THE UNIT.

NOTE:- BRACES, WHICH HAVE TABS THAT ARE NOT BENT AT 90 DEG. ARE TO AVOID PACKAGING DAMAGE. STRAIGHTEN THEM TO 90 DEG. PRIOR TO FASTENING.

CAUTION:

TO REDUCE THE LIKELIHOOD OF SUPPLY /RETURN AIR BYPASS AND PROMOTE A PROPER SEAL WITH THE RTU, DUCT WORK / DUCT DROPS / DIFFUSER ASSEMBLIES MUST BE SUPPORTED INDEPENDENTLY TO THE BUILDING STRUCTURE.

STEP #6

IF BOLTED ASSEMBLY IS PREFERRED, INSTALL A BOLT, NUT & WASHER IN EACH HOLE IN LOCKING TAB,(HARDWARE INCLUDED) SEE FIG.#4

FRAME APPLICATION AND LOCATION

THIS ROOF MOUNTING FRAME PROVIDES NECESSARY SUPPORT WHEN UNIT IS INSTALLED. THE FRAME CAN BE INSTALLED DIRECTLY ON DECK HAVING ADEQUATE STRUCTURAL STRENGTH OR ON ROOF SUPPORTS UNDER DECK.

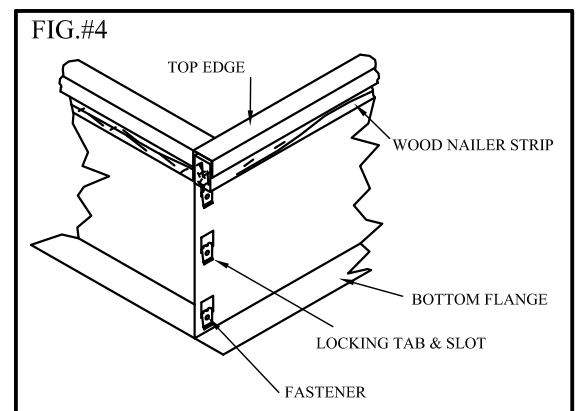
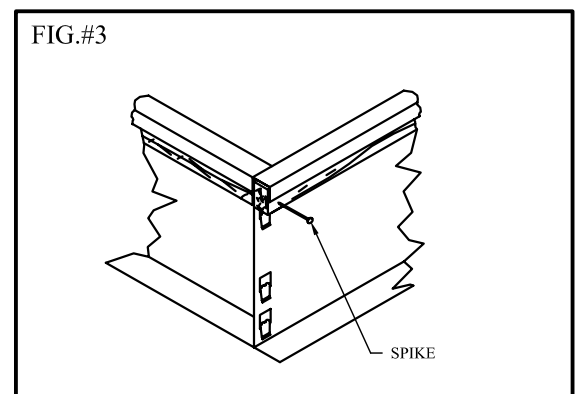
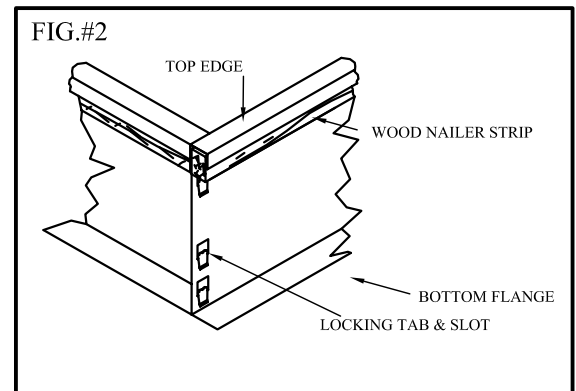
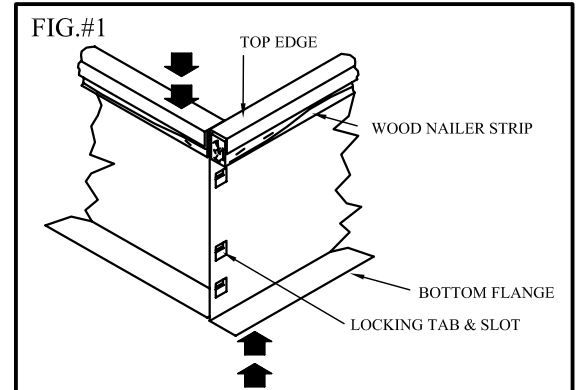

5000328

DEC., 02, 2015



INSTALLATION INSTRUCTIONS *HYBRID ROOF CURB

SECURING FRAME

TO ASSURE PROPER MATING WITH UNIT, IT IS MANDATORY THE MOUNTING FRAME BE SQUARE TO ROOF STRUCTURE AS FOLLOWS:

- 1 - WITH FRAME SITUATED LEVEL IN DESIRED LOCATION ON ROOF TRUSSES, TACK WELD ONE CORNER OF FRAME.
- 2 - MEASURE FRAME DIAGONALLY FROM ONE CORNER AS SHOWN IN FIG.#5. THESE DIMENSIONS MUST BE EQUAL FOR FRAME TO SQUARE.
- 3 - IT IS EXTREMELY IMPORTANT TO SIGHT FRAME FROM ALL CORNERS TO MAKE CERTAIN FRAME IS NOT TWISTED ACROSS TOP SIDE. SHIM FRAME UNDER ANY LOW SIDES.
- 4 - AFTER FRAME HAS BEEN SQUARED, STRAIGHTENED AND SHIMMED, WELD OR ATTACH FRAME SECURELY TO ROOF.

MAXIMUM SLOPE TOLERANCE: 1/16" PER LINEAR FOOT IN ANY DIRECTION.

IMPORTANT: SQUARING FRAME

FRAME IS SQUARE WHEN CORNERS 1 TO 2 AND 3 TO 4 ARE EQUAL (REF FIG #5)

IF A POURED ROOF IS USED, SUCH AS CONCRETE, BE SURE INSIDE OF MOUNTING FRAME IS ADEQUATELY BRACED TO ENSURE A SQUARE AND LEVEL FRAME.

CURBING AND FLASHING

- 1 - OUTSIDE OF FRAME SHOULD BE INSULATED WITH A RIGID TYPE INSULATION, PREFERABLY 2 IN. (51mm) THICK. DO NOT USE COMBUSTIBLE MATERIAL FOR FILLING AROUND FRAME.
- 2 - COUNTERFLASH AND SEAL AROUND FRAME AS SHOWN IN FIG.#6.

FIG.#5

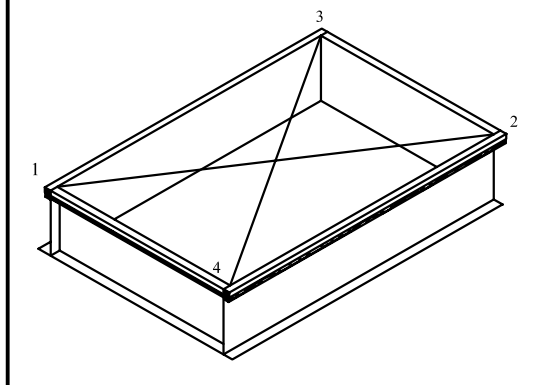

* US PATENTS 5188333, 5255887
CANADIAN PATENT 2073900
ADDITIONAL PATENTS PENDING

CURBING AND FLASHING

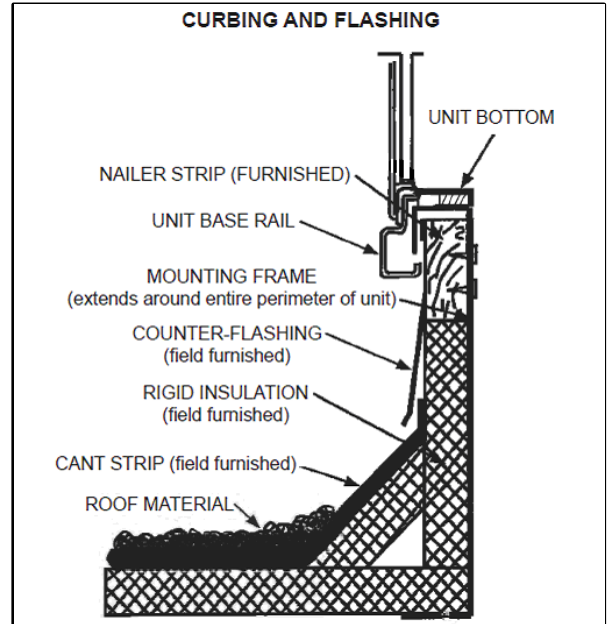
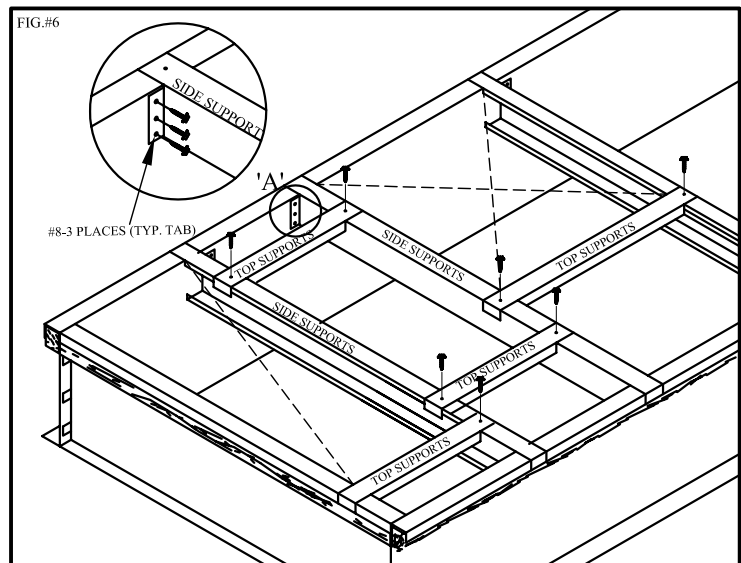

FIG.#6



5000328

DEC., 02, 2015