

PACKAGED HEAT PUMP



**LDT**

**Enlight™ Rooftop Units  
Dual-Fuel - High Efficiency - 60 Hz**

**COMMERCIAL  
PRODUCT SPECIFICATIONS**

Bulletin No. 210983  
January 2024  
Supersedes August 2023



**ENLIGHT**



**ASHRAE 90.1  
COMPLIANT**

**SMARTWIRE™ SYSTEM**

**13 to 20 Tons**

**Net Cooling Capacity - 150,000 to 224,000 Btuh  
Net Heating Capacity - 144,000 to 224,000 Btuh  
Gas Input Heat Capacity - 169,000 to 480,000 Btuh**

**MODEL NUMBER IDENTIFICATION**

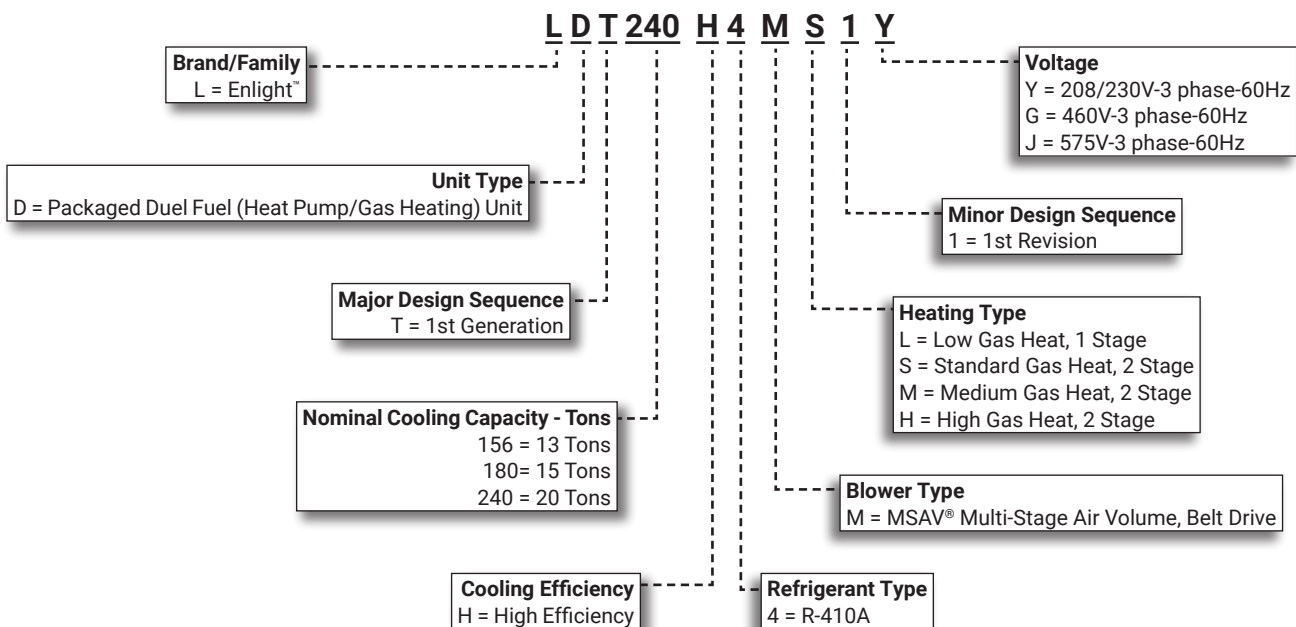

## FEATURE HIGHLIGHTS

Enlight™ rooftop units featuring the Lennox® CORE Control System create a bright future through a highly energy-efficient and environmentally sustainable design. Comprehensive configurations meet a wide range of applications, making it the most flexible product line Lennox has to offer.

1. Scroll Compressors
2. Thermal Expansion Valves
3. Filter/Driers
4. Outdoor Coil Copper Tube Construction
5. Outdoor Coil Fan Motors
6. Stainless Steel Heat Exchanger
7. Inshot Burners
8. Heavy Gauge Steel Cabinet
9. Hinged Access Panels
10. MSAV® Multi-Stage Air Volume Blower
11. Disconnect Switch (option)
12. Air Filters
13. Lennox CORE® Control System
14. Economizer (option)
15. Downflow Barometric Relief Dampers (option)
16. Power Exhaust Fans (option)

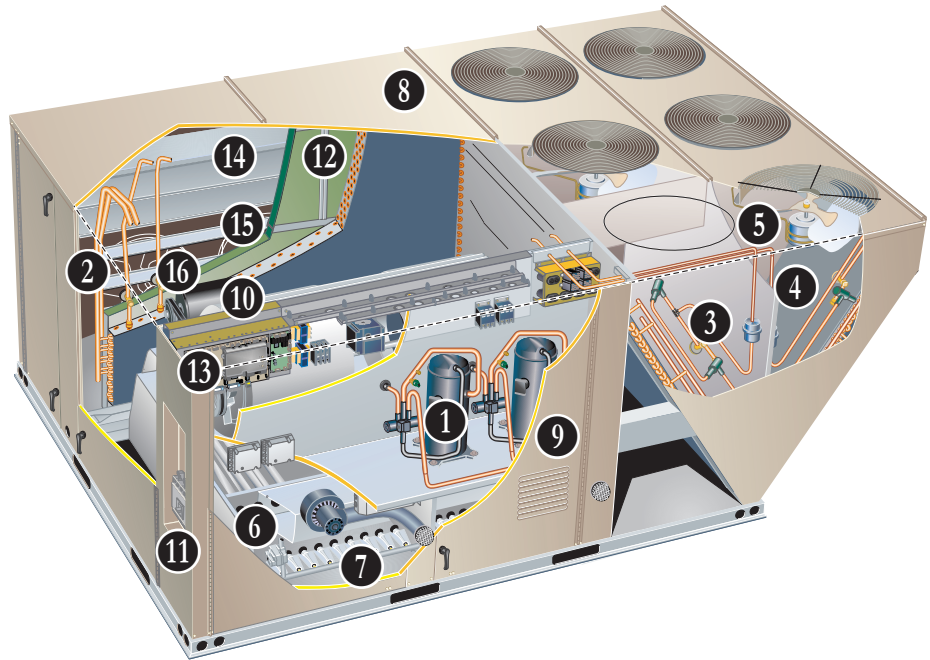

## CONTENTS

Approvals And Warranty . . . . .	3
Blower Data . . . . .	26
Control System . . . . .	8
Cooling/Heating Ratings . . . . .	23
Electrical Data . . . . .	29
Features And Benefits . . . . .	3
High Altitude Derate . . . . .	22
Model Number Identification . . . . .	1
Optional Conventional Temperature Control Systems . . . . .	12
Options / Accessories . . . . .	17
Outdoor Sound Data . . . . .	31
Sequence Of Operation . . . . .	14
Specifications . . . . .	21
- Gas Heat . . . . .	22
Weight Data . . . . .	32
- Accessories . . . . .	34
- Options / Accessories . . . . .	32
- Unit . . . . .	32

## APPROVALS AND WARRANTY

### APPROVALS

- AHRI Standard 340/360 certified
- ETL and CSA listed
- CSA certified energy ratings
- Unit and components ETL, NEC and CEC bonded for grounding to meet safety standards for servicing
- All models are ASHRAE 90.1 energy efficiency compliant and meet or exceed requirements of Section 6.8
- All models meet DOE 2023 energy efficiency standards
- All models meet California Code of Regulations, Title 24 and ASHRAE 90.1 Section 6.4.3.10 requirements for staged airflow
- ISO 9001 Registered Manufacturing Quality System

### WARRANTY

- Stainless Steel Heat Exchanger - Limited fifteen years
- Compressors - Limited five years
- Lennox CORE® Unit Controller - Limited three years
- Variable Frequency Drive (VFD) (optional) - Limited five years
- High Performance Economizers (optional) - Limited five years
- All other covered components - Limited one year

## FEATURES AND BENEFITS

### DUAL-FUEL OPERATION

#### (Heating Mode)

- Operates the heat pump for 1st stage heating
  - If 1st stage heat settings are not met, 2nd stage activates gas heating (secondary heat source)
- Mechanical heat pump operation automatically terminates on gas heat start-up
- Lennox® CORE Control System automatically changes blower speeds between heat pump heating and gas heating
- Blower operates in high speed during 1st stage (heat pump) operation and terminates during changeover to gas heat operation
- Blower starts when heat exchanger is warm, and runs in high speed during 2nd stage (gas heat) operation
  - If continuous blower operation is available on the thermostat, a change in blower speed automatically occurs during heat pump to gas heat changeover

### COOLING/HEATING SYSTEM

- Designed to maximize sensible and latent cooling performance at design conditions
- Mechanical cooling operates from 0°F to 125°F
- Mechanical Heating System operates down to 35°F ambient (default dual fuel balance point)
- Mechanical heating operates at ambient temperatures above -15°F
- Gas Heating operates from 35°F down to -40°F

**NOTE** - Optional Low Temperature Vestibule Heater extends gas heat operation down to -60°F.

#### R-410A Refrigerant

- Non-chlorine based
- Ozone-friendly

### 1 Compressor System

- Scroll compressors on all models for high performance, reliability and quiet operation
- Resiliently mounted on rubber grommets for quiet operation

#### Compressor Crankcase Heaters

- Protects against refrigerant migration that can occur during low ambient operation

### 2 Thermal Expansion Valves

- Ensures optimal performance throughout the application range
- Removable element head

#### Reversing Valves

- 4-way interchange reversing valve rapidly changes the direction of refrigerant flow resulting in quick changeover from cooling to heating and vice versa

### 3 Filter/Driers

- High capacity filter/drier protects the system from dirt and moisture

#### High Pressure Switches

- Protects the compressors from overload conditions such as dirty condenser coils, blocked refrigerant flow, or loss of outdoor fan operation

#### Low Pressure Switches

- Protects the compressors from low pressure conditions such as low refrigerant charge, or low/no airflow

#### Indoor Coil Freeze Protection

- Protects the evaporator coil from damaging ice build-up due to conditions such as low/no airflow, or low refrigerant charge

## FEATURES AND BENEFITS

### COOLING/HEATING SYSTEM (continued)

- 4 Outdoor Coil**
- Copper tube construction
  - Enhanced rippled-edge aluminum fins
  - Flared shoulder tubing connections
  - Silver soldered construction
  - Factory leak tested
  - Two independent slanted coils for easy cleaning

#### **Indoor Coil**

- Copper tube construction
- Enhanced rippled-edge aluminum fins
- Flared shoulder tubing connections
- Silver soldered construction for improved heat transfer
- Factory leak tested
- Cross row circuiting with rifled tubing optimizes both sensible and latent cooling capacity

#### **Antimicrobial Condensate Drain Pan**

- Composite pan, sloped to meet drainage requirements per ASHRAE 62.1
- Anti-Microbial additive prevents growth of mold and mildew, which improves indoor air quality and reduces drain line blockage
- Side or bottom drain connections

**5 Outdoor Coil Fan Motors**

- All models have PSC motors
- Thermal overload protected
- Totally enclosed
- Permanently lubricated ball bearings
- Shaft up
- Wire basket mount

#### **Outdoor Coil Fans**

- PVC coated fan guard furnished

#### **Required Selections**

##### **Cooling Capacity**

- Specify nominal cooling capacity

#### **Options/Accessories**

##### **Field Installed**

###### **Condensate Drain Trap**

- Available in copper or PVC

###### **Factory or Field Installed**

###### **Drain Pan Overflow Switch**

- Monitors condensate level in drain pan
- Shuts down unit if drain becomes clogged

### HEATING SYSTEM

- 6 Heat Exchanger**
- Tubular construction, stainless steel
  - Life-cycle tested
- 7**
- Aluminized steel inshot burners
  - Direct spark ignition
  - Electronic flame sensor
  - Combustion air inducer
  - Redundant automatic dual stage gas valve with manual shut-off

#### **Electronic Pilot Ignition**

- Electronic spark igniter provides positive direct ignition of burners on each operating cycle
- Permits main gas valve to stay open only when the burners are proven to be lit
- If loss of flame occurs, gas valve closes, shutting off the gas to the burners
- LED indicates status and aids in troubleshooting
- Factory installed in the control section

#### **Limit Controls**

- Redundant limit controls with fixed temperature setting
- Protects heat exchanger and other components from overheating

#### **Safety Switches**

- Flame roll-out switch
- Flame sensor
- Combustion air inducer proving switch
- Protects system operation

#### **Required Selections**

##### **Gas Input Choice - Order one:**

- Low Gas Heat, 1 Stage (169,000 Btuh)
- Standard Gas Heat, 2 Stage (84,500/260,000 Btuh)
- Medium Gas Heat, 2 Stage (117,000/360,000 Btuh)
- High Gas Heat, 2 Stage (156,000/480,000 Btuh)

**NOTE** – Two-stage heat models can be operated with four stages of gas heating when controlled in either zone sensor, Discharge Air Control, or fresh air tempering mode on the Lennox CORE® Control System (available when using the CS8500 thermostat or when connected to Building Automation Systems using BACnet, LonTalk, or S-Bus protocols). See Gas Heating Specifications table.

## FEATURES AND BENEFITS

### HEATING SYSTEM (continued)

#### Options/Accessories

#### Field Installed

##### Bottom Gas Piping Kit

- Allows bottom gas entry
- Factory installed kit is furnished with the unit for field installation

##### Combustion Air Intake Extensions

- Recommended for use with existing flue extension kits in areas where high snow areas can block intake air
- Order two kits

##### Low Temperature Vestibule Heater

- Electric heater automatically controls minimum temperature in gas burner compartment when temperature is below -40°F
- CSA certified to allow operation of unit down to -60°F

##### LPG/Propane Kits

- Conversion kit to field change over units from Natural Gas to LPG/Propane
- Order two kits

##### Vertical Vent Extension Kit

- Use to exhaust flue gases vertically above unit
- Required when unit vent is too close to fresh air intakes per building codes
- Also prevents ice formation on intake louvers
- Kit contains vent transition, vent tee, drain cap and installation hardware
- Order two kits.

**NOTE** - Straight vent pipes (4 in. B-Vent) and caps are not furnished and must be field supplied. Refer to kit instructions for additional information.

### CABINET

#### 8 Construction

- Heavy-gauge steel panels
- Full perimeter heavy-gauge galvanized steel base rail
- Base rails have rigging holes
- Three sides of the base rail have forklift slots
- Raised edges around duct and power entry openings in the bottom of the unit for water protection

#### Airflow Choice

- Units are shipped in downflow (vertical) return air flow configuration

**NOTE** - Units can be field converted to horizontal air flow with optional Horizontal Return Air Panel Kit and Horizontal Roof Curb.

#### Power/Gas Entry

- Electrical and gas lines can be routed through the unit base or through horizontal access knock-outs

#### Exterior Panels

- Constructed of heavy-gauge, galvanized steel
- Textured pre-paint with polyurethane finish

- Cyclic salt fog and UV exposure up to 1,680 hours per ASTM D5894

#### Insulation

- Fully insulated with non-hygroscopic fiberglass insulation (conditioned areas)
- Unit base is fully insulated
- Base insulation serves as an air seal to the roof curb, eliminating the need to add a seal during installation

#### 9 Hinged Access Panels

- Filter section
- Blower section
- Heating section
- Compressor/controls section
- Panel seals and quarter-turn latching handles provide a tight air and water seal

#### Required Selections

#### Airflow Configuration

- Specify downflow or horizontal

#### Options/Accessories

#### Factory Installed

##### Corrosion Protection

- Completely flexible immersed coating
- Electrodeposited dry film process (AST ElectroFin E-Coat)
- ASTM B117 / DIN 53167 Salt Spray - 15,000+ hours
- ASTM G85 Annex A3 SWAAT Modified Salt Spray - 3,000 hours
- VA Master Construction Specification Division 23 for High Humidity Installations
- CID AA-52474A (GSA)
- Indoor Corrosion Protection:
  - Coated coil
  - Coated reheat coil
  - Painted blower housing
  - Painted base
- Outdoor Corrosion Protection:
  - Coated coil
  - Painted outdoor base

#### Factory or Field Installed

##### Combination Coil/Hail Guards

- Heavy gauge steel frame
- Painted to match cabinet
- Expanded metal mesh protects outdoor coil

##### Horizontal Return Air Panel Kit

- Required for horizontal applications with Horizontal Roof Curb
- Contains panel with return air opening for field replacement of existing unit panel and panel to cover bottom return air opening in unit
- See dimension drawings

## FEATURES AND BENEFITS

### **BLOWER**

A wide selection of supply air blower options are available to meet a variety of airflow requirements

#### **Motor**

- Overload protected, equipped with ball bearings
- Belt drive motors are offered on all models and are available in several different sizes to maximize air performance

#### **Motor Efficiency**

- All blower motors 5 hp and above meet minimum energy efficiency standards in accordance with the Energy Independence and Security Act (EISA) of 2007

### **10 Supply Air Blower**

- Forward curved blades
- Double inlet
- Blower wheel is statically and dynamically balanced
- Ball bearings
- Adjustable pulley (allows speed change)
- Blower assembly slides out of unit for servicing
- Grease fittings furnished
- MSAV® Multi-Stage Air Volume stages the amount of airflow according to compressor stages, heating demand, ventilation demand or smoke alarm
- MSAV® Multi-Stage Air Volume utilizes a Variable Frequency Drive (VFD) to stage the supply blower airflow
- VFD alters the frequency and voltage of the power supply to the blower to control blower speed
- The amount of airflow for each stage can be set according to a parameter in the Lennox® CORE Unit Controller
- Unit is shipped from the factory with preset airflow
- LDT180H models with MSAV® Multi-Stage Air Volume can be ordered with or without an Electronic Bypass Control
- If equipped with the bypass control the MSAV® Multi-Stage Air Volume features manual (default) or automatic electronic bypass control of the VFD
- In case of a VFD malfunction, a VFD alarm is generated by the Lennox® CORE Unit controller
- VFD can be manually bypassed to continue unit operation at full blower speed or the unit controller can be set to automatically switch to full blower speed if a VFD alarm is generated
- VFD has an operational range of -40 to 125°F outdoor air ambient temperature
- Lower operating costs are obtained when the blower is operated on lower speeds

**NOTE** - Units equipped a Variable Frequency Drive (VFD) are designed to operate on balanced, three-phase power. Operating units on unbalanced three-phase power will reduce the reliability of all electrical components in the unit. Unbalanced power is a result of the power delivery system supplied by the local utility company. Factory-installed inverters are sized to drive blower motors with an equivalent current rating using balanced three-phase power. If unbalanced three-phase power is supplied, the installer must replace the existing factory-installed inverter with an inverter that has a higher current rating to allow for the imbalance. Refer to the installation instructions for additional information and replacement information.

#### **Ordering Information**

- Specify motor horsepower and drive kit number when base unit is ordered

#### **Options/Accessories**

#### **Field Installed**

##### **Blower Belt Auto-Tensioner**

- Provides proper tension to belt drive blower belt without the need for regular adjustments
- Maintains airflow and proper performance

#### **ELECTRICAL**

##### **SmartWire™ System**

- Keyed and color-coded wiring connectors prevent miswiring
- Wire coloring scheme is standardized across all models
- Each connection is intuitively labeled to make troubleshooting and servicing quick and easy

##### **Electrical Plugs**

- Positive connection electrical plugs connect common accessories or maintenance parts for easy removal or installation

##### **Phase/Voltage Detection**

- Monitors power supply to ensure correct phase at unit start-up
  - If phase is incorrect, the unit will not start and an alarm code reports to the unit controller
- Prevents unit start-up if the unit is the incorrect phase; unit start-ups in the wrong phase could lead to issues such as compressors functioning in reverse
- Monitors power supply voltage to ensure proper voltage
  - If voltage is not correct (over/under voltage conditions) the unit will not start and an alarm code reports to the unit controller

## FEATURES AND BENEFITS

### Required Selections

#### Voltage Choice

- Specify when ordering base unit

### Options/Accessories

#### Factory Installed

##### Circuit Breakers

- HACR type
- For overload and short circuit protection
- Factory wired and mounted in the power entry panel
- Current sensitive and temperature activated
- Manual reset

##### Short-Circuit Current Rating (SCCR)

- Higher short circuit protection up to 100kA

**NOTE** - Disconnect Switch is furnished and factory installed with High SCCR option.

#### Factory or Field Installed

##### 11 Disconnect Switch

- Accessible outside of unit
- Spring loaded weatherproof cover furnished

##### GFI Service Outlets (2)

- 115V ground fault circuit interrupter (GFCI) type options:
  - Factory installed, powered and wired
  - Factory installed, non-powered, field wired
  - Field installed, non-powered, field wired

#### Field Installed

##### GFI Weatherproof Cover

- Single-gang cover
- Heavy-duty UV-resistant polycarbonate case construction
- Hinged base cover with gasket

### INDOOR AIR QUALITY

##### 12 Air Filters

- Disposable 2 inch MERV 4 filters furnished as standard

### Options/Accessories

#### Factory or Field Installed

##### Healthy Climate® High Efficiency Air Filters

- Disposable MERV 8 and MERV 13 (Minimum Efficiency Reporting Value based on ASHRAE 52.2) efficiency 2 inch pleated filters

#### Field Installed

##### Healthy Climate® High Efficiency MERV 16 Air Filters

- Disposable MERV 16 (Minimum Efficiency Reporting Value based on ASHRAE 52.2) efficiency 2 inch pleated filters
- Healthy Climate® UVC Germicidal Light Kit

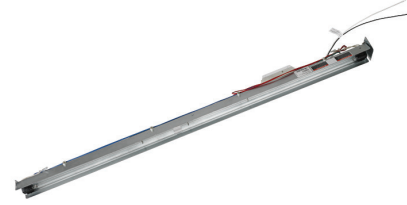

- Germicidal lamps emit ultra-violet (UV-C) energy, which has been proven to be effective in reducing microbes such as viruses, bacteria, yeasts, and molds
  - UV-C energy greatly reduces the growth and proliferation of mold and other bioaerosols (bacteria and viruses) on illuminated surfaces (particularly coil and drain pan)
  - Destroys the organism or controls its ability to reproduce
  - Field installed in the blower/evaporator coil section
  - Magnetic safety interlock terminates power when access panels are removed
  - All necessary hardware for installation is included
  - Lamps operate on 110/230V-1ph power supply
- NOTE** - Step-down transformer may be ordered separately for 460V and 575V units.
- Approved by ETL

##### Indoor Air Quality (CO<sub>2</sub>) Sensors

- Monitors CO<sub>2</sub> levels
- Reports to the Lennox® CORE unit controller which adjusts economizer dampers as needed

##### Replacement Filter Media Kit With Frame

- Replaces existing pleated filter media
- Includes washable metal mesh screen and metal frame with clip for holding replaceable non-pleated filter

## CONTROL SYSTEM

### CONTROL SYSTEM

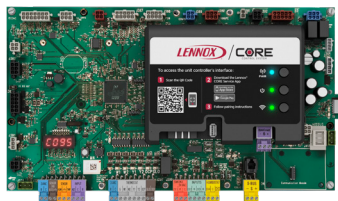

- 13 The Lennox® CORE Control System is designed to accelerate equipment install and service. Standard with all Enlight™ rooftop units, control system integrates key technologies that lower installation costs, drive system efficiency, and protect your investments.

The Lennox® CORE Unit Controller is a microprocessor-based controller that provides flexible control of all unit functions.

#### CORE Service Mobile App

- Guided Setup with progress indicators, detailed help, and exportable summaries to manage simple, trouble-free setup, reducing commissioning times
- Enhanced Test Functionality provides real-time sensor readings, trending, and reports that enable easy troubleshooting
- Ability to set and configure parameters of the CORE Control System to manage sequence of operation
- Economizer test function ensures economizer is operating correctly



#### Additional Features:

- Built-In 7-Segment Display shows Unit Status and active alarms for easy troubleshooting
- Buttons for test and clearing delays
- SmartWire™ System with keyed and removable screw terminals ensure correct field wiring
- Built-in BACnet MS/TP and IP allow open integration to building management systems.
- Two-port Ethernet Switch enables daisy chaining for BACnet IP and automatic firmware updates

**NOTE** - Unit Internet Connection required.

- Profile setup copies key settings between units with the same configuration to reduce setup time
- USB port allows a technician to download and transfer unit information to help verify service was performed
- USB software updates on the Lennox® CORE Unit Controller enhance functionality without the need to change components
- Unit Controller Software

#### Configurable Built-In Functions

- Discharge Air Cooling Control
- Up to three distinct Cooling Airflows in Thermostat Mode
- Programmable independent heating, ventilation and cooling blower speeds

- Discharge Air Heating Control
- Economizer Control Options (See Economizer / Exhaust Air / Outdoor Air sections)
- Exhaust Fan Control Modes for fresh air damper position
- Configurable Morning Warm-up
- Night Setback Mode
- Fresh Air Tempering for Improved Ventilation
- Demand Control Ventilation
- Low Ambient Controls for operation down to 0°F
- Two Defrost Control Methods (demand and timed - heat pumps only)

#### Component Protection / Unit Safeguards:

- Compressor Time-Off Delay
- Adjustable Blower On/Off Delay
- Return Air Temperature Limit Control
- Safety Switch Input allows Controller to respond to a external safety switch trip
- Service Relay Output
- Thermostat Bounce Delay
- Smoke Alarm Mode has four choices (unit off, positive pressure, negative pressure, purge)
- "Strike Three" Protection
- Gas Valve Time Delay Between First and Second Stage
- Minimum Compressor Run Time

#### Control Methods / Interfaces:

- DDC and 24V Thermostat
- BACnet MS/TP and IP
- LONTalk (Factory and Field Option)
- Lennox S-BUS
- Compatibility with Lennox Wireless Zone Sensors
- Zone Temperature Sensor Input
- Dehumidistat and Humidity Sensor Inputs
- Indoor Air Quality Inputs (2)
- Built-in Control Parameter Defaults
- Permanent Diagnostic Code Storage
- Field Adjustable Control Parameters (Over 200 settings)
- Multiple Configurable Digital Inputs
- LED Indicators
- PC Interface connects the Lennox® CORE Unit Controller to a PC with the Lennox Unit Controller Software

**NOTE** - Lennox® CORE Control System features vary with the type of rooftop unit in which the control is installed.



## CONTROL SYSTEM

### LENNOX® CORE CONTROL SYSTEM (continued)

#### Controls Options

#### Factory or Field Installed

##### Blower Proving Switch

- Monitors blower operation, shuts down unit if blower fails

##### Dirty Filter Switch

- Senses static pressure increase and issues alarm if necessary

##### Fresh Air Tempering

- Used in applications with high outside air requirements
- Controller energizes the first stage heat as needed to maintain a minimum supply air temperature for comfort, regardless of the thermostat demand
- When ordered as a factory option, sensor ships with the unit for field installation

##### Smoke Detector

- Photoelectric type
- Installed in supply air section, return air section or both sections
- Available with power board and single sensor (supply or return) or power board and two sensors (supply and return)
- Power board located in unit control compartment

##### Interoperability via BACnet® or LonTalk® Protocols

- Communication compatible with third-party automation systems that support the BACnet Application Specific Controller device profile, LonMark® Space Comfort Controller functional profile, or LonMark Discharge Air Controller functional profile

### Commercial Control Systems

#### Field Installed

##### Thermostats

- Control system and thermostat options, see page 12

## OPTIONS / ACCESSORIES

### ECONOMIZER

- Economizer operation is set and controlled by the Lennox® CORE Unit Controller
- Simple plug-in connections from Economizer to unit controller for easy installation
- All Enlight™ rooftop units are equipped with factory installed CEC Title 24 approved sensors for outside, return and discharge air temperature monitoring

**NOTE** - Optional sensors may be used instead of unit sensors to determine whether outdoor air is suitable for free cooling. See Options/Accessories table.

#### Factory or Field Installed

#### **14** High Performance Economizer

- Approved for California Title 24 building standards
- Low leakage dampers are Air Movement and Control Association International (AMCA) Class 1A Certified - Maximum 3 CFM per sq. ft. leakage at 1 in. w.g.
- ASHRAE 90.1 and IECC compliant
- Downflow or Horizontal with Outdoor Air Hood
- Outdoor Air Hood with mist elimination is included when Economizer is factory installed and is furnished with Economizer when ordered for field installation

**NOTE** - Downflow or horizontal economizer applications require optional Downflow or Horizontal Barometric Relief Dampers with Exhaust Hood.

- Linked damper action
- High torque 24-volt fully-modulating spring return damper motor
- Return air and outdoor air dampers
- Plug-in connections to unit

**NOTE** - High Performance Economizers are not approved for use with enthalpy controls in Title 24 applications.

**NOTE** - The Free Cooling setpoint for Title 24 applications must be set based on the Climate Zone where the system is installed. See Section 140.4 "Prescriptive Requirements for Space Conditioning Systems" of the California Energy Commission's 2019 Building Energy Efficiency Standards.

**NOTE** - Refer to Installation Instructions for complete setup information.

#### Differential Sensible Control

- Factory setting
- Uses outdoor air and return air sensors that are furnished with the unit
- The Lennox® CORE Unit Controller compares outdoor air temperature with return air
- When the outdoor air is below the configured setpoint and cooler than return air, the controller activates the Economizer

## OPTIONS / ACCESSORIES

### ECONOMIZER (continued)

#### **Factory or Field Installed**

**NOTE** - Differential Sensible Control can be configured in the field to provide Offset Differential Sensible Control or Single Sensible Control.

**NOTE** - In Offset Differential Sensible Control mode, the Economizer is enabled if the temperature differential (offset) between outdoor air and return air reaches the configured setpoint.  
In Single Sensible Control mode, the Economizer is enabled when outdoor air temperature falls below the configured setpoint.

#### **Global Control**

- Unit controller communicates with a DDC system with one global sensor (enthalpy or sensible)
- Determines whether outside air is suitable for free cooling on all units connected to the control system
- Sensor must be field provided

#### **Single Enthalpy Control (Not for Title 24)**

- Outdoor air enthalpy sensor enables Economizer if the outdoor enthalpy is less than the setpoint of the control

#### **Differential Enthalpy Control (Not for Title 24)**

- Order two Single Enthalpy Controls
- One is field installed in the return air section
- One is installed in the outdoor air section
- Allows the Economizer control to select between outdoor air or return air, whichever has lower enthalpy

#### **Field Installed**

##### **Outdoor Air CFM Control**

- Maintains constant outdoor air volume levels on the supply air fan and varying unit airflows
- Velocity sensor located in the rooftop unit outdoor air section, the Lennox® CORE Unit Controller changes the Economizer position to help minimize the effect of supply fan speed changes on outdoor air volume levels
- Setpoint for outdoor air volume is established by field testing

**NOTE** - Not available with Demand Control Ventilation (CO<sub>2</sub> Sensor) or Building Pressure Control.

##### **Building Pressure Control**

- Maintains constant building pressure level
- Includes a static pressure transducer and outdoor static pressure assembly
- Using differential pressure information between the outdoor air and the building air, the Lennox® CORE Unit Controller changes the Economizer position to help maintain a constant building pressure

**NOTE** - Not available with Demand Control Ventilation (CO<sub>2</sub> Sensor) or Outdoor Air CFM Control.

### EXHAUST

#### **Factory or Field Installed**

##### **15 Downflow Barometric Relief Dampers**

- Allow relief of excess air
- Aluminum blade dampers prevent blow back and outdoor air infiltration during off cycle
- Exhaust hood is factory installed when dampers are factory installed with Economizer
- Exhaust hood is furnished with dampers when ordered for field installation
- Bird screen furnished

##### **16 Power Exhaust Fans**

- Install internal to unit for downflow applications only with Economizer option
- Provides exhaust air pressure relief
- Interlocked to run when supply air blower is operating
- Fans run when outdoor air dampers are 50% open (adjustable)
- Motor is overload protected
- Dual propeller type fans are 20 in. diameter
- Five blades
- Two 1/3 hp motors
- SCCR rated

**NOTE** - Requires Economizer with furnished Outdoor Air Hood and Downflow Barometric Relief Dampers.

**NOTE** - All models are equipped with 2-stage power exhaust fans. Power exhaust operates in 1st stage (one fan) up to 70% of supply air blower speed. Both exhaust fans operate in 2nd stage when supply air blower speed is above 70% (adjustable) of full speed.

#### **Field Installed**

##### **Horizontal Barometric Relief Dampers**

- For use when unit is configured for horizontal applications requiring an Economizer
- Allows relief of excess air
- Aluminum blade dampers prevent blow back and outdoor air infiltration during off cycle
- Field installed in return air duct
- Bird screen and hood furnished

## OPTIONS / ACCESSORIES

### **OUTDOOR AIR OPTIONS**

#### **Factory or Field Installed**

##### **Outdoor Air Damper**

- Downflow or Horizontal
- Linked mechanical dampers
- 0 to 25% (fixed) outdoor air adjustable
- Installs in unit
- Includes outdoor air hood
- Motorized model features fully modulating spring return damper motor with plug-in connection
- Manual model features parallel blade, gear-driven dampers with adjustable fixed position

**NOTE** - Manual Outdoor Air Damper is a field installed option only.

**NOTE** - Outdoor Air Hood is included when damper is factory installed and is furnished with damper when ordered for field installation.

#### **ROOF CURBS**

##### **Field Installed**

- Nailer strip furnished (downflow only)
- Mates to unit
- US National Roofing Contractors Approved
- Shipped knocked down

##### **Downflow**

##### **Hybrid Roof Curbs**

- Interlocking tabs fasten corners together
- No tools required for assembly
- Can also be fastened together with furnished hardware
- Available in 8, 14, 18, and 24 inch heights

##### **Adjustable Pitch Curb**

- Fully adjustable pitch curbs (3/4 in. per foot in any direction) provide a level platform for rooftop units allowing flexible installations on roofs with uneven or sloped angles
- Interlocking tabs fasten corners together
- No tools required for assembly
- Hardware is furnished to connect upper curb with lower curb
- Available in 14 inch height

##### **Horizontal**

- Meet National Roofing Code requirements
- Converts unit from downflow to horizontal (side) air flow
- Return air is on unit
- Supply air is on curb
- See dimension drawings
- Available in 26, 30, 37, and 41 inch heights

**NOTE** - Requires Horizontal Return Air Panel Kit.

**NOTE** - Optional Insulation Kit is available to help prevent sweating.

##### **Adaptor Curbs (not shown)**

- Curbs are regionally sourced
- Dimensions vary based upon the source

**NOTE** - Contact your local sales representative for a detailed cut sheet with applicable dimensions.

### **CEILING DIFFUSERS**

#### **Field Installed**

##### **Ceiling Diffusers (Flush or Step-Down)**

- White powder coat finish on diffuser face and grilles
- Insulated UL listed duct liner
- Diffuser box has collars for duct connection
- Step-down diffusers have double deflection blades
- Flush diffusers have fixed blades
- Provisions for suspending
- Internally sealed to prevent recirculation
- Removable return air grille
- Adapts to T-bar ceiling grids or plaster ceilings

##### **Transitions (Supply and Return)**

- Used with diffusers
- Installs in roof curb
- Galvanized steel construction
- Flanges furnished for duct connection to diffusers
- Fully insulated

## OPTIONAL CONVENTIONAL TEMPERATURE CONTROL SYSTEMS

### CS8500 Commercial 7-Day Programmable Thermostat

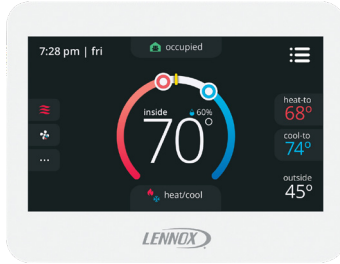

- Fully Communicating Sensor
- Full Color Touchscreen Interface
- Variable Speed System Control (On Compatible Units)
- Up To 4 Heat / 4 Cool
- Built-In Sensors For Temperature, Humidity And Optional CO<sub>2</sub>
- Remote Sensor Options For Occupancy, Temperature
- BACnet Capable Options
- 5-2 or 7-Day Scheduling
- Smooth Setback Recovery
- Heat/Cool Auto-Changeover
- Four-Wire Installation
- FDD, ASHRAE, IECC Compliant

### CS7500 Commercial 7-Day Programmable Thermostat



- Premium Universal Thermostat
- Full Color Touchscreen Interface
- Up To 4 Heat / 3 Cool
- Built-In Sensors For Temperature and Humidity
- Remote Sensors Options For Temperature, Discharge Air, Outdoor Air
- 5-2 or 7-Day Scheduling
- Smooth Setback Recovery
- Heat/Cool Auto-Changeover
- FDD, ASHRAE, IECC Compliant

### CS3000 Commercial 5-2 Day Programmable Thermostat



- Conventional Multi-Stage Thermostat
- Intuitive Display
- Push-Button Operation
- Up To 2 Heat / 2 Cool
- Built-In Temperature Sensor
- Remote Temperature Sensing
- Up to 5-2 Day Scheduling
- Smooth Setback Recovery
- Heat/Cool Auto-changeover

### Wireless/Wired Temperature/Humidity Room Sensor (LCS-5030)



- Simple Push-Button Override
- Variable Speed System Control (On Compatible Units)
- Up To 4 Heat / 4 Cool
- AA Battery / 24VAC Powered
- Bluetooth™ Mesh Operation
- SBUS Wired Operation
- Automatic Sensor Averaging
- Locking Hex Screw

### Wireless Repeater for LCS-5030



- Extends Effective Range of Wireless Sensor (LCS-5030)
- 24VAC Only
- Locking Hex Screw

**NOTE** - Wireless only.

## OPTIONAL CONVENTIONAL TEMPERATURE CONTROL SYSTEMS

### Wired Temperature/Humidity Room Sensor (Non-Communicating)



- Terminal blocks for wiring connections
- Five-wire sensor connection
- Off-white plastic enclosure
- Non-adjustable
- Relative humidity range: 0 -100%
- +/- 3% Accuracy

## OPTIONAL CONVENTIONAL TEMPERATURE CONTROL SYSTEMS

Description	Catalog No.
<b>CS8500 Commercial 7 Day Programmable Thermostat</b>	
CS8500 7-Day Thermostat	No CO <sub>2</sub> Sensing <b>24K55</b>
	With CO <sub>2</sub> Sensing <b>24K53</b>
Sensors/Accessories	<sup>1</sup> Remote non-adjustable wall-mount 10k <b>47W37</b>
	<sup>1</sup> Remote non-adjustable wall-mount 11k <b>94L61</b>
<b>Sysbus Network Cable (Yellow) for CS8500 and LCS-5030 Wired Room Sensor</b>	
Twisted pair 100% shielded communication cable, Red and Black	500 ft. box <b>27M19</b>
22 AWG, yellow jacket, rated at 75°C, 300V, Plenum rated	1000 ft. box <b>94L63</b>
Insulation - Low smoke PVC, NEC, CMP	2500 ft. roll <b>68M25</b>
<b>CS7500 Commercial 7-Day Programmable Thermostat</b>	
CS7500 7-Day Thermostat	<b>24K41</b>
Sensors/Accessories	<sup>2</sup> Remote non-adjustable wall-mount 20k <b>47W36</b>
	<sup>2</sup> Remote non-adjustable wall-mount 10k <b>47W37</b>
	Remote non-adjustable discharge air (duct mount) <b>19L22</b>
	Outdoor temperature sensor <b>X2658</b>
<b>CS3000 Commercial 5-2 Day Programmable Thermostat</b>	
CS3000 5-2 Day Thermostat	<b>11Y05</b>
Sensors/Accessories	Remote non-adjustable wall mount 10k averaging <b>47W37</b>
	Thermostat wall mounting plate <b>X2659</b>
<b>Universal Thermostat Guard with Lock (clear)</b>	
	Inside Dimensions (H x W x D) 5-7/8 x 8-3/8 x 3 in. <b>39P21</b>
<b>Temperature/Humidity Room Sensors</b>	
LCS-5030 Wireless/Wired Temperature/Humidity Room Sensor	<b>21L07</b>
Wireless Repeater for LCS-5030	<b>21L09</b>
A335MT13AE1 Wired Temperature/Humidity Room Sensor (Non-Communicating)	<b>21W06</b>

<sup>1</sup> Up to nine of the same type remote temperature sensors can be connected in parallel.

<sup>2</sup> Remote wall-mount sensors can be applied in any of the following combinations:

One Sensor - (1) 47W36, Two Sensors - (2) 47W37, Three Sensors - (2) 47W36 and (1) 47W37

Four Sensors - (4) 47W36, Five Sensors - (3) 47W36 and (2) 47W37

**Objective:** Outline the unit functions as a result of room thermostat or zone sensor demands.

**Given:** When economizer is present, it will function as an integral part of the unit cooling system. When not present, unit will function as if economizer is present but outdoor ambient is high and sensed as not suitable.

**UNIT OPERATION WITH 2-STAGE THERMOSTAT (2 COOL AND 2 HEAT STAGES, Y1, Y2, W1, W2)**

**Supply Air Blower Speed**

Unit has following supply air blower speed setting:

- Ventilation speed
- Cooling Speed - Low
- Cooling Speed - High
- Heating speed
- Smoke speed (Used only in smoke removal option - not discussed)

**<sup>1</sup> Unit Features An Economizer And Outdoor Air Is Suitable**

Cooling - Thermostat Mode (Y1, Y2)

**Y1 Demand:**

All compressors are off, supply air blower is on low cooling speed to minimize blower power consumption, economizer modulates (minimum to maximum open position) to maintain 55°F supply air temperature (default unit controller setting).

**Y2 Demand:**

All compressors are off, supply air blower is on high cooling speed providing higher cooling capacity, and economizer modulates to maintain 55°F supply air temperature. If economizer stays at maximum open for 3 minutes, compressor 1 is energized while supply air blower stays on high cooling speed providing maximum cooling capacity.

<sup>1</sup> *Outdoor air suitability is determined by the energy state of outdoor ambient (enthalpy or sensible) and its ability to achieve the desired free cooling effects. Outdoor air suitability can also be determined by a third party controller and provided to the rooftop unit via a network connection.*

**Unit Does Not Feature An Economizer Or Outdoor Air Is Not Suitable**

**Y1 Demand:**

Compressor 1 operates, and supply air blower operates at low cooling speed.

**Y2 Demand:**

All compressors operate and supply air blower operates at high cooling speed.

**UNIT OPERATION WITH 3-STAGE THERMOSTAT OR ZONE SENSOR (3 COOL AND 2 HEAT STAGES, Y1, Y2, Y3 AND W1, W2)****Supply Air Blower Speed**

Unit has following supply air blower speed setting:

- Ventilation speed
- Cooling Speed - Low
- Cooling Speed - Medium
- Cooling Speed - High
- Heating speed
- Smoke speed (Used only in smoke removal option - not discussed)

**<sup>1</sup> Unit Features An Economizer And Outdoor Air Is Suitable**

Cooling - Thermostat or Zone Sensor Mode (Y1, Y2, Y3)

**Y1 Demand:**

All compressors are off, supply air blower is on low cooling speed to minimize blower power consumption, economizer modulates (minimum to maximum open position) to maintain 55°F supply air temperature (default unit controller setting).

**Y2 Demand:**

All compressors are off, supply air blower is on high cooling speed providing higher cooling capacity, and economizer modulates to maintain 55°F supply air temperature. If economizer stays at maximum open for 3 minutes, compressor 1 is energized while supply air blower stays on high cooling speed providing maximum cooling capacity. After compressors are energized the economizer stays at maximum open.

**Y3 Demand:**

Compressors 1 and 2 are energized while supply air blower stays on high cooling speed.

<sup>1</sup> *Outdoor air suitability is determined by the energy state of outdoor ambient (enthalpy or sensible) and its ability to achieve the desired free cooling effects. Outdoor air suitability can also be determined by a third party controller and provided to the rooftop unit via a network connection.*

**Unit Does Not Feature An Economizer or Outdoor Air Is Not Suitable**

Cooling - Thermostat or Zone Sensor Mode (Y1, Y2, Y3)

**Y1 Demand:**

Compressor 1 operates at part load and supply air blower operates at low cooling speed.

**Y2 Demand:**

Compressor 1 operates at part load with compressor 2 ON, and supply air blower operates at medium cooling speed.

**Y3 Demand:**

All compressors operate and supply air blower operates at high cooling speed.

**Defrost Mode**

Coil Sensors (RT48 - Circuit 1 and RT49 - Circuit 2) and Ambient Sensor (RT17) provides input to the Lennox® CORE Unit Controller to initiate a defrost cycle if needed.

Coil sensors are located on a return bend for each circuit on the front of the outdoor coil.

Ambient sensor is located on the inside of the corner mullion on the back of the outdoor coil section.

If a coil sensor measures a temperature below 35°F during mechanical heating mode, defrost logic is enabled. The system will constantly monitor coil and ambient temperatures and will initiate a defrost cycle if the controller determines that the target temperature difference between the coil and ambient temperature has been satisfied, or when the accumulated run time with coil temperature below 35°F reaches 6 hours.

Defrost will not be activated on more than one circuit at the time.

If the ambient sensor fails, or the circuit is in uncalibrated state, the controller will switch to time/temperature defrost operation.

*NOTE - Gas heat is energized during a defrost cycle to maintain discharge air temperature.*

Heating - Thermostat or Zone Sensor

**W1 Demand:**

A first-stage heating demand (W1) will activate the controller to check the Outdoor Air Temperature and Balance Point (default is 35°F). User adjustable from 10°F to 76°F.

If the Outdoor Air Temperature is more than the Balance Point, the controller will energize compressors 1 and 2 and the outdoor fans.

If the Outdoor Air Temperature is less than the Balance Point, the controller will lock out Mechanical Heating and will enable gas heat only.

*NOTE – L1 and L2 reversing valves are de-energized in the heating mode.*

**W2 Demand:**

A second-stage heating demand (W2) will de-energize Mechanical Heating and High Gas Heat will be energized.

**Modulating Outdoor Air Damper**

The minimum damper position for “occupied low blower” and “occupied high blower” is adjusted during unit setup to provide minimum fresh air requirements per ASHRAE 62.1 at the corresponding supply air blower speeds.

When supply air blower is off or the unit is in unoccupied mode, the outdoor air damper is closed.

When unit is in occupied mode and supply air blower is operating at a speed below the “midpoint” blower speed, the outdoor air damper is at minimum “low blower” position.

When unit is in occupied mode and supply air blower is operating at a speed equal to or above the “midpoint” blower speed, the outdoor air damper is at minimum “high blower” position.

*NOTE - The “midpoint” blower speed is an average of the minimum and maximum blower speed (minimum speed + maximum speed divided by 2).*

**Power Exhaust Operation**

*NOTE - POWER EXHAUST OPERATION IS THE SAME FOR ALL CONTROL OPTIONS*

MSAV® models are equipped with 2-stage power exhaust fans. Power exhaust fans operate when economizer outdoor air dampers are 50% open (adjustable). Power exhaust operates in 1st stage (one fan) up to 70% of supply air blower speed. 2nd stage power exhaust fans (both fans) operate when supply air blower speed is above 70% (adjustable) of full speed.



## OPTIONS / ACCESSORIES

Item Description	Catalog Number	Unit Model No			
		156	180	240	
<b>COOLING SYSTEM</b>					
Condensate Drain Trap	PVC	<b>22H54</b>	X	X	X
	Copper	<b>76W27</b>	X	X	X
Conventional Fin/Tube Condenser Coil	Factory		O	O	O
Drain Pan Overflow Switch		<b>21Z07</b>	OX	OX	OX
Refrigerant Type		R-410A	O	O	O
<b>HEATING SYSTEM</b>					
Bottom Gas Piping Kit		<b>85M31</b>	X	X	X
Combustion Air Intake Extensions (order two)		<b>89L97</b>	X	X	X
Gas Heat Input	Low - 169,000 Btuh	Factory	O	O	
	Standard - 260,000 Btuh	Factory	O	O	O
	Medium - 360,000 Btuh	Factory	O	O	O
	High - 480,000 Btuh	Factory		O	O
Low Temperature Vestibule Heater	208/230V-3ph	<b>22H58</b>	X	X	X
	460V-3ph	<b>22H59</b>	X	X	X
	575V-3ph	<b>13X68</b>	X	X	X
LPG/Propane Conversion Kits (Order 2 kits)	Low Heat	<b>14N28</b>	X	X	
	Standard Heat	<b>14N28</b>	X	X	X
	Medium Heat	<b>14N29</b>	X	X	X
	High Heat	<b>14N30</b>	X	X	X
Vertical Vent Extension Kit (Order two kits)		<b>42W16</b>	X	X	X
<b>BLOWER - SUPPLY AIR</b>					
Blower Option	MSAV® Multi-Stage Air Volume (With VFD Bypass Control)	Factory	O	O	
	MSAV® Multi-Stage Air Volume (Without VFD Bypass Control)	Factory	O	O	O
Motors	Belt Drive - 3 hp	Factory	O	O	
	Belt Drive - 5 hp	Factory	O	O	O
	Belt Drive - 7.5 hp	Factory		O	O
	Belt Drive - 10 hp	Factory			O
Drive Kits See Blower Data Tables for usage and selection	Kit #1 535-725 rpm	Factory	O	O	
	Kit #2 710-965 rpm	Factory	O	O	
	Kit #3 685-856 rpm	Factory	O	O	O
	Kit #4 850-1045 rpm	Factory	O	O	O
	Kit #5 945-1185 rpm	Factory	O	O	O
	Kit #6 850-1045 rpm	Factory		O	O
	Kit #7 945-1185 rpm	Factory		O	O
	Kit #8 1045-1285 rpm	Factory		O	O
	Kit #10 1045-1285 rpm	Factory			O
	Kit #11 1135-1365 rpm	Factory			O
	Blower Belt Auto-Tensioner	<b>24B80</b>		X	X
<b>CABINET</b>					
Combination Coil/Hail Guards		<b>23U71</b>	OX	OX	OX
Corrosion Protection		Factory	O	O	O

NOTE - Catalog numbers shown are for ordering field installed accessories.

OX - Configure To Order (Factory Installed) or Field Installed

O = Configure To Order (Factory Installed)

X = Field Installed

## OPTIONS / ACCESSORIES

Item Description	Catalog Number	Unit Model No		
		156	180	240
<b>CONTROLS</b>				
Blower Proving Switch	<b>21Z10</b>	OX	OX	OX
Commercial Controls	CPC Einstein Integration	Factory	O	O
	LonTalk® Module	<b>54W27</b>	OX	OX
	Novar® LSE	Factory	O	O
Dirty Filter Switch	<b>53W68</b>	OX	OX	OX
Fresh Air Tempering	<b>21Z08</b>	OX	OX	OX
Smoke Detector - Supply or Return (Power board and one sensor)	<b>22H56</b>	OX	OX	OX
Smoke Detector - Supply and Return (Power board and two sensors)	<b>22H57</b>	OX	OX	OX
<b>INDOOR AIR QUALITY</b>				
<b>Air Filters</b>				
Healthy Climate® High Efficiency Air Filters 24 x 24 x 2 (Order 6 per unit)	MERV 8	<b>54W67</b>	OX	OX
	MERV 13	<b>52W40</b>	OX	OX
	MERV 16	<b>21U42</b>	X	X
Replacement Media Filter With Metal Mesh Frame (includes non-pleated filter media)		<b>44N61</b>	X	X
<b>Indoor Air Quality (CO<sub>2</sub>) Sensors</b>				
Sensor - Wall-mount, off-white plastic cover with LCD display		<b>77N39</b>	X	X
Sensor - Wall-mount, off-white plastic cover, no display		<b>23V86</b>	X	X
Sensor - Black plastic case with LCD display, rated for plenum mounting		<b>87N52</b>	X	X
Sensor - Wall-mount, black plastic case, no display, rated for plenum mounting		<b>87N54</b>	X	X
CO <sub>2</sub> Sensor Duct Mounting Kit - for downflow applications		<b>85L43</b>	X	X
Aspiration Box - for duct mounting non-plenum rated CO <sub>2</sub> sensors ( <b>77N39</b> )		<b>90N43</b>	X	X
<b>Needlepoint Bipolar Ionization (NPBI)</b>				
Needlepoint Bipolar Ionization (NPBI) Kit		<b>21U37</b>	X	X
		<b>21U38</b>		X
<b>UVC Germicidal Light Kit</b>				
<sup>1</sup> Healthy Climate® UVC Light Kit (110/230v-1ph)		<b>21A94</b>	X	X
Step-Down Transformers	460V primary, 230V secondary	<b>10H20</b>	X	X
	575V primary, 230V secondary	<b>10H21</b>	X	X
<b>ELECTRICAL</b>				
Voltage 60 Hz	208/230V - 3 phase	Factory	O	O
	460V - 3 phase	Factory	O	O
	575V - 3 phase	Factory	O	O
HACR Circuit Breakers		Factory	O	O
<sup>2</sup> Short-Circuit Current Rating (SCCR) of 100kA (includes Phase/Voltage Detection)		Factory	O	O
Disconnect Switch (see Disconnect Table for usage, page 30)	80 amp	<b>54W88</b>	OX	OX
	150 amp	<b>54W89</b>	OX	OX
GFI Service Outlets	15 amp non-powered, field-wired (208/230V, 460V, 575V)	<b>74M70</b>	OX	OX
	15 amp factory-wired and powered (208/230V, 460V)	Factory	O	O
	<sup>3</sup> 20 amp non-powered, field-wired (208/230V, 460V, 575V)	<b>67E01</b>	X	X
	<sup>3</sup> 20 amp non-powered, field-wired (575V)	Factory	O	O
Weatherproof Cover for GFI		<b>10C89</b>	X	X

<sup>1</sup> Lamps operate on 110-230V single-phase power supply. Step-down transformer may be ordered separately for 460V and 575V units. Alternately, 110V power supply may be used to directly power the UVC ballast(s).

<sup>2</sup> Disconnect Switch is furnished and factory installed with High SCCR option.

<sup>3</sup> Canada requires a minimum 20 amp circuit. Select 20 amp, non-powered, field wired GFI.

NOTE - Catalog numbers shown are for ordering field installed accessories.

OX - Configure To Order (Factory Installed) or Field Installed

O = Configure To Order (Factory Installed)

X = Field Installed

## OPTIONS / ACCESSORIES

Item Description	Catalog Number	Unit Model No		
		156	180	240
<b>ECONOMIZER</b>				
<b>High Performance Economizer (Approved for California Title 24 Building Standards AMCA Class 1A Certified)</b>				
High Performance Economizer (Downflow or Horizontal) Includes Economizer Dampers with Outdoor Air Hood Downflow Applications - Use furnished Outdoor Air Hood - Order Downflow Barometric Relief Dampers with Exhaust Hood separately Horizontal Applications - Use furnished Outdoor Air Hood - Order Horizontal Barometric Relief Dampers with Exhaust Hood separately	22J18	OX	OX	OX
<b>Economizer Controls</b>				
Differential Enthalpy (Not for Title 24)	Order 2 21Z09	OX	OX	OX
Sensible Control	Sensor is Furnished Factory	O	O	O
Single Enthalpy (Not for Title 24)	21Z09	OX	OX	OX
Global Control	Sensor Field Provided Factory	O	O	O
Building Pressure Control	13J77	X	X	X
Outdoor Air CFM Control	13J76	X	X	X
<b>Barometric Relief Dampers With Exhaust Hood</b>				
Downflow Barometric Relief Dampers	54W78	OX	OX	OX
Horizontal Barometric Relief Dampers	16K99	X	X	X
<b>OUTDOOR AIR</b>				
<b>Outdoor Air Dampers With Outdoor Air Hood</b>				
Motorized	22J27	OX	OX	OX
Manual	13U05	X	X	X
<b>1 POWER EXHAUST (DOWNFLOW APPLICATIONS ONLY)</b>				
Standard Static, SCCR Rated	208/230V 22H90	OX	OX	OX
	460V 22H91	OX	OX	OX
	575V 22V34	OX	OX	OX

<sup>1</sup> Field installed Power Exhaust requires Economizer with Outdoor Air Hood and Downflow Barometric Relief Dampers with Exhaust Hood. Must be ordered separately.

NOTE - Catalog numbers shown are for ordering field installed accessories.

OX - Configure To Order (Factory Installed) or Field Installed

O = Configure To Order (Factory Installed)

X = Field Installed

## OPTIONS / ACCESSORIES

Item Description	Catalog Number	Unit Model No		
		156	180	240
<b>ROOF CURBS</b>				
<b>Hybrid Roof Curbs, Downflow</b>				
8 in. height	11F58	X	X	X
14 in. height	11F59	X	X	X
18 in. height	11F60	X	X	X
24 in. height	11F61	X	X	X
<b>Adjustable Pitch Curb</b>				
14 in. height	43W26	X	X	X
<b>Standard Roof Curbs, Horizontal - Requires Horizontal Return Air Panel Kit</b>				
26 in. height - slab applications	11T89	X	X	X
37 in. height - rooftop applications	11T96	X	X	X
<b>Insulation Kit For Standard Horizontal Roof Curbs</b>				
For 26 in. Curb	73K32	X	X	X
For 37 in. Curb	73K34	X	X	X
<b>Horizontal Return Air Panel Kit</b>				
Required for Horizontal Applications with Roof Curb	87M00	X	X	X
<b>CEILING DIFFUSERS</b>				
Step-Down - Order one	RTD11-185S	13K63	X	X
	RTD11-275S	13K64		X
Flush - Order one	FD11-185S	13K58	X	X
	FD11-275S	13K59		X
Transitions (Supply and Return) - Order one	C1DIFF33C-1	12X68	X	X
	C1DIFF34C-1	12X70		X

NOTE - Catalog numbers shown are for ordering field installed accessories.

OX - Configure To Order (Factory Installed) or Field Installed

O = Configure To Order (Factory Installed)

X = Field Installed

## SPECIFICATIONS

General Data		Nominal Tonnage	13 Ton	15 Ton	20 Ton	
		Model Number	LDT156H4M	LDT180H4M	LDT240H4M	
		Efficiency Type	High	High	High	
		Blower Type	MSAV®	MSAV®	MSAV®	
			Multi-Stage Air Volume	Multi-Stage Air Volume	Multi-Stage Air Volume	
<b>Cooling Performance</b>	Gross Cooling Capacity - Btuh		154,000	182,000	233,000	
	<sup>1</sup> Net Cooling Capacity - Btuh		150,000	176,000	224,000	
	<sup>1</sup> AHRI Rated Air Flow - cfm		4500	5500	7000	
	Total Unit Power - kW		12.6	16.1	20.5	
	<sup>1</sup> IEER (Btuh/Watt)		15.5	15.3	15.3	
	<sup>1</sup> EER (Btuh/Watt)		11.9	10.9	10.9	
<b>Refrigerant Charge</b>	Refrigerant Type		R-410A	R-410A	R-410A	
	Circuit 1		21 lbs. 0 oz.	22 lbs. 12 oz.	22 lbs. 8 oz.	
	Circuit 2		21 lbs. 0 oz.	21 lbs. 12 oz.	21 lbs. 8 oz.	
<b>Heating Performance</b>	<sup>1</sup> Total High Heat Capacity - Btuh		144,000	174,000	224,000	
	Total Unit Power - kW		12.4	14.8	19.3	
	<sup>1</sup> C.O.P.		3.40	3.40	3.40	
	<sup>1</sup> Total Low Heat Capacity - Btuh		80,000	96,000	128,000	
	Total Unit Power (kW)		11.1	13.3	17.8	
	<sup>1</sup> C.O.P.		2.10	2.10	2.10	
<b>Gas Heating Options Available</b>			See page 22			
<b>Compressor Type (number)</b>			Scroll (2)	Scroll (2)	Scroll (2)	
<b>Outdoor Coils</b>	Net face area (total) - sq. ft.		55.1	55.1	55.1	
	Number of rows		2	2	2	
	Fins per inch		20	20	20	
<b>Outdoor Coil Fans</b>	Motor - (No.) horsepower		(6) 1/3	(6) 1/3	(6) 1/3	
	Motor rpm		1075	1075	1075	
	Total Motor watts		2150	2150	2150	
	Diameter - (No.) in.		(6) 24	(6) 24	(6) 24	
	Number of blades		3	3	3	
	Total Air volume - cfm		16,300	16,300	16,300	
<b>Indoor Coils</b>	Net face area (total) - sq. ft.		21.4	21.4	21.4	
	Tube diameter - in.		3/8	3/8	3/8	
	Number of rows		4	4	4	
	Fins per inch		14	14	14	
	Drain connection - No. and size		(1) 1 in. FPT	(1) 1 in. FPT	(1) 1 in. FPT	
	Expansion device type		Balance Port Thermostatic Expansion Valve (removable element head)			
<sup>2</sup> <b>Indoor Blower and Drive Selection</b>	Nominal motor output		3 hp, 5 hp	3 hp, 5 hp, 7.5 hp	5 hp, 7.5 hp, 10 hp	
	Max. usable motor output (US)		3.45 hp, 5.75 hp	3.45 hp, 5.75 hp, 8.63 hp	5.75 hp, 8.62 hp, 11.5 hp	
	Motor - Drive kit number		3 hp	3 hp	5 hp	
			Kit 1 535-725 rpm Kit 2 710-965 rpm	Kit 1 535-725 rpm Kit 2 710-965 rpm	Kit 3 685-856 rpm Kit 4 850-1045 rpm Kit 5 945-1185 rpm	
			5 hp	5 hp	7.5 hp	
			Kit 3 - 685-856 rpm Kit 4 850-1045 rpm Kit 5 945-1185 rpm	Kit 3 - 685-856 rpm Kit 4 850-1045 rpm Kit 5 945-1185 rpm	Kit 6 850-1045 rpm Kit 7 945-1185 rpm Kit 8 1045-1285 rpm	
				7.5 hp	10 hp	
				Kit 6 850-1045 rpm Kit 7 945-1185 rpm Kit 8 1045-1285 rpm	Kit 7 945-1185 rpm Kit 10 1045-1285 rpm Kit 11 1135-1365 rpm	
		Blower wheel nominal D x W - in.		(2) 15 x 15 in.	(2) 15 x 15 in.	(2) 15 x 15
	<b>Filters</b>	Type of filter		MERV 4, Disposable		
Number and size - in.			(6) 24 x 24 x 2			
<b>Electrical characteristics</b>			208/230V, 460V or 575V - 60 hertz - 3 phase			

NOTE - Net capacity includes evaporator blower motor heat deduction. Gross capacity does not include evaporator blower motor heat deduction.

<sup>1</sup> AHRI Certified to AHRI Standard 340/360:

**Cooling Ratings** - 95°F outdoor air temperature and 80°F db/67°F wb entering indoor coil air.

**High Temperature Heating Ratings** - 47°F db/43°F wb outdoor air temperature and 70°F entering indoor coil air.

**Low Temperature Heating Ratings** - 17°F db/15°F wb outdoor air temperature and 70°F entering indoor coil air.

<sup>2</sup> Using total air volume and system static pressure requirements determine from blower performance tables rpm and motor output required. Maximum usable output of motors furnished are shown. In Canada, nominal motor output is also maximum usable motor output. If motors of comparable output are used, be sure to keep within the service factor limitations outlined on the motor nameplate.

NOTE - Motor service factor limit - 1.0.

## SPECIFICATIONS

## GAS HEAT

Usage Data		Model Number	LDT156 LDT180	LDT156 LDT180 LDT240	LDT180 LDT240	
Heat Input Type			Low (L)	Standard (S)	Medium (M)	High (H)
Number of Gas Heat Stages			One	<sup>1</sup> Two	<sup>1</sup> Two	<sup>1</sup> Two
<b><sup>1</sup> Gas Heating Performance</b>	Input - Btuh	First Stage	169,000	85,000	117,000	156,000
		Second Stage	---	169,000	234,000	312,000
		Third Stage	---	214,000	297,000	396,000
		Fourth Stage	---	260,000	360,000	480,000
	Output - Btuh	First Stage	135,000	---	---	---
		Second Stage	---	---	---	---
		Third Stage	---	---	---	---
		Fourth Stage	---	211,000	292,000	389,000
Temperature Rise Range - °F	First Stage	15-45	15-45	30-60	40-70	
	Second Stage	---	---	---	---	
Minimum Air Volume - cfm			3000	4500	4500	5125
Thermal Efficiency			80%	81%	81%	81%
Gas Supply Connections			1 in. NPT	1 in. NPT	1 in. NPT	1 in. NPT
Recommended Gas Supply Pressure - in. w.g.	Natural		7	7	7	7
	LPG/Propane		11	11	11	11
Gas Supply Pressure Range	Min./Max. (Natural)	4.7 - 10.5 in. w.g.				
	Min./Max. (LPG)	10.8 - 13.5 in. w.g.				

<sup>1</sup> Two-stage heat models can be operated with four stages of gas heating when controlled in either zone sensor, Discharge Air Control, or fresh air tempering mode on the Lennox® CORE unit controller (available when using the CS8500 thermostat or when connected to Building Automation Systems using BACnet, LonTalk, or S-Bus protocols).

## HIGH ALTITUDE DERATE

**NOTE** - Units may be installed at altitudes up to 2000 feet above sea level without any modification.

At altitudes above 2000 feet, units must be derated to match gas manifold pressures shown in table below.

At altitudes above 4500 feet units must be derated 4% for each 1000 feet above sea level.

**NOTE** - This is the only permissible derate for these units.

Refer to the Installation Instructions for more detailed information.

### ONE STAGE HEAT

No Adjustment Required

### TWO STAGE HEAT

Heat Input Type	Altitude Feet	Gas Manifold Pressure - in. w.g.		Input Rate (Btuh)	
		Natural Gas	LPG/Propane Gas	First Stage	Second Stage
Standard (2 stage)	2001 - 4500	1.6 / 3.1	4.4 / 8.9	169,000	239,000
Medium (2 stage)	2001 - 4500	1.6 / 3.1	4.4 / 8.9	234,000	331,000
High (2 stage)	2001 - 4500	1.6 / 3.1	4.4 / 8.9	312,000	442,000

### FOUR STAGE HEAT

<sup>1</sup> Heat Input Type	Altitude Feet	Gas Manifold Pressure - in. w.g.		Input Rate (Btuh)			
		Natural Gas	LPG/Propane Gas	First Stage	Second Stage	Third Stage	Fourth Stage
Standard (4 stage)	2001 - 4500	1.6 / 3.1	4.4 / 8.9	85,000	169,000	204,000	239,000
Medium (4 stage)	2001 - 4500	1.6 / 3.1	4.4 / 8.9	117,000	234,000	283,000	331,000
High (4 stage)	2001 - 4500	1.6 / 3.1	4.4 / 8.9	156,000	312,000	377,000	442,000

<sup>1</sup> Four-Stage Gas Heating is field configured.

# COOLING/HEATING RATINGS

NOTE – For Temperatures and Capacities not shown in tables, see bulletin – Cooling Unit Rating Table Correction Factor Data in Miscellaneous Engineering Data section.

## 13 TON - COOLING LDT156H4M (1 COMPRESSOR - PART LOAD)

Entering Wet Bulb Temperature	Total Air Volume	Outdoor Air Temperature Entering Outdoor Coil																							
		65°F						75°F						85°F						95°F					
		Total Cool Cap.	Comp. Motor Input	Sensible To Total Ratio (S/T) Dry Bulb			Total Cool Cap.	Comp. Motor Input	Sensible To Total Ratio (S/T) Dry Bulb			Total Cool Cap.	Comp. Motor Input	Sensible To Total Ratio (S/T) Dry Bulb			Total Cool Cap.	Comp. Motor Input	Sensible To Total Ratio (S/T) Dry Bulb						
				75°F	80°F	85°F			75°F	80°F	85°F			75°F	80°F	85°F			75°F	80°F	85°F				
cfm	kBtuh	kW				kBtuh	kW				kBtuh	kW				kBtuh	kW								
63°F	1800	58.6	1.96	.77	.94	1.00	55.8	2.26	.79	.96	1.00	52.6	2.62	.81	.99	1.00	49.1	3.03	.83	1.00	1.00				
	2250	61.8	1.93	.84	1.00	1.00	58.8	2.23	.86	1.00	1.00	55.8	2.59	.89	1.00	1.00	52.8	3.00	.92	1.00	1.00				
	2700	65.2	1.89	.91	1.00	1.00	62.2	2.20	.94	1.00	1.00	58.9	2.57	.97	1.00	1.00	55.7	2.98	1.00	1.00	1.00				
67°F	1800	62.8	1.92	.59	.74	.90	59.5	2.22	.59	.76	.92	56.0	2.59	.60	.78	.95	52.6	3.01	.61	.80	.98				
	2250	65.5	1.89	.63	.81	.99	62.2	2.20	.64	.83	1.00	58.6	2.57	.65	.86	1.00	54.9	2.98	.67	.89	1.00				
	2700	67.5	1.87	.67	.88	1.00	64.1	2.18	.68	.91	1.00	60.2	2.55	.70	.94	1.00	56.6	2.97	.72	.98	1.00				
71°F	1800	67.2	1.87	.41	.57	.72	64.0	2.18	.41	.58	.73	60.4	2.55	.41	.58	.74	56.7	2.97	.41	.59	.77				
	2250	70.6	2.14	.42	.61	.79	66.6	2.16	.42	.62	.81	62.7	2.53	.43	.63	.83	59.0	2.95	.44	.65	.86				
	2700	71.8	1.82	.44	.65	.86	68.1	2.15	.45	.67	.88	64.5	2.51	.46	.68	.91	60.6	2.93	.46	.71	.95				

## 13 TON - COOLING LDT156H4M (2 COMPRESSORS - PART LOAD / FULL LOAD)

Entering Wet Bulb Temperature	Total Air Volume	Outdoor Air Temperature Entering Outdoor Coil																							
		85°F						95°F						105°F						115°F					
		Total Cool Cap.	Comp. Motor Input	Sensible To Total Ratio (S/T) Dry Bulb			Total Cool Cap.	Comp. Motor Input	Sensible To Total Ratio (S/T) Dry Bulb			Total Cool Cap.	Comp. Motor Input	Sensible To Total Ratio (S/T) Dry Bulb			Total Cool Cap.	Comp. Motor Input	Sensible To Total Ratio (S/T) Dry Bulb						
				75°F	80°F	85°F			75°F	80°F	85°F			75°F	80°F	85°F			75°F	80°F	85°F				
cfm	kBtuh	kW				kBtuh	kW				kBtuh	kW				kBtuh	kW								
63°F	3000	124.4	7.04	.69	.82	.94	117.1	7.96	.70	.84	.95	109.5	9.37	.71	.86	.97	98.7	10.72	.73	.90	.99				
	3750	132.1	7.07	.74	.89	.99	124.3	7.99	.76	.91	1.00	116.4	9.39	.78	.93	1.00	107.9	11.97	.80	.95	1.00				
	4500	138.5	7.09	.79	.94	1.00	131.3	8.02	.81	.95	1.00	120.8	9.41	.83	.98	1.00	114.2	11.96	.86	1.00	1.00				
67°F	3000	133.4	7.07	.54	.67	.79	125.8	7.99	.54	.68	.81	118.0	9.39	.55	.69	.82	109.3	11.97	.55	.70	.85				
	3750	141.0	7.11	.58	.72	.86	133.0	8.03	.58	.73	.88	122.3	9.43	.59	.76	.90	115.8	11.97	.59	.77	.92				
	4500	147.2	7.14	.60	.77	.92	138.3	8.05	.61	.79	.93	129.9	9.10	.62	.81	.95	116.9	11.19	.63	.85	.97				
71°F	3000	142.5	7.10	.41	.53	.64	135.1	8.03	.41	.53	.65	126.1	9.06	.40	.53	.66	117.4	11.95	.40	.54	.68				
	3750	150.6	7.13	.42	.56	.69	142.3	8.05	.42	.56	.71	131.0	9.54	.42	.58	.73	125.0	11.17	.42	.58	.74				
	4500	154.2	7.54	.43	.59	.75	148.1	8.08	.43	.60	.76	140.0	9.54	.44	.61	.78	130.3	11.19	.43	.62	.81				

## 13 TON - COOLING LDT156H4M (2 COMPRESSORS - FULL LOAD)

Entering Wet Bulb Temperature	Total Air Volume	Outdoor Air Temperature Entering Outdoor Coil																							
		85°F						95°F						105°F						115°F					
		Total Cool Cap.	Comp. Motor Input	Sensible To Total Ratio (S/T) Dry Bulb			Total Cool Cap.	Comp. Motor Input	Sensible To Total Ratio (S/T) Dry Bulb			Total Cool Cap.	Comp. Motor Input	Sensible To Total Ratio (S/T) Dry Bulb			Total Cool Cap.	Comp. Motor Input	Sensible To Total Ratio (S/T) Dry Bulb						
				75°F	80°F	85°F			75°F	80°F	85°F			75°F	80°F	85°F			75°F	80°F	85°F				
cfm	kBtuh	kW				kBtuh	kW				kBtuh	kW				kBtuh	kW								
63°F	4160	150.1	8.13	.73	.88	1.00	141.2	9.14	.75	.90	1.00	132.0	10.28	.76	.93	1.00	122.7	11.57	.79	.96	1.00				
	5200	157.4	8.20	.79	.96	1.00	148.8	9.20	.81	.99	1.00	140.0	10.34	.84	1.00	1.00	131.3	13.31	.86	1.00	1.00				
	6240	164.7	8.26	.85	1.00	1.00	157.0	9.73	.88	1.00	1.00	147.8	10.41	.90	1.00	1.00	137.0	13.98	.94	1.00	1.00				
67°F	4160	160.1	8.22	.57	.71	.85	151.2	9.23	.57	.72	.87	141.5	10.36	.58	.74	.89	131.8	13.31	.59	.76	.93				
	5200	167.2	8.28	.61	.77	.93	156.2	10.15	.61	.79	.95	147.8	10.41	.62	.81	.98	135.0	13.99	.64	.84	1.00				
	6240	172.7	8.34	.65	.83	.99	166.1	10.18	.65	.85	1.00	149.7	10.89	.68	.89	1.00	143.3	13.99	.69	.91	1.00				
71°F	4160	169.9	8.31	.42	.55	.68	160.4	10.17	.42	.56	.70	148.9	10.88	.42	.57	.72	142.3	13.99	.42	.58	.73				
	5200	177.9	8.38	.43	.59	.75	171.6	9.84	.44	.60	.77	159.6	10.92	.44	.61	.78	148.8	14.01	.44	.63	.82				
	6240	186.0	8.86	.45	.63	.81	175.0	9.50	.45	.64	.82	164.4	10.96	.46	.66	.85	149.7	12.76	.46	.69	.90				

## 13 TON - HEATING LDT156H4M

Indoor Coil Air Volume 70°F Dry Bulb cfm	Air Temperature Entering Outdoor Coil									
	65°F		45°F		25°F		5°F		-15°F	
	Total Heating Capacity	Comp. Motor Input	Total Heating Capacity	Comp. Motor Input	Total Heating Capacity	Comp. Motor Input	Total Heating Capacity	Comp. Motor Input	Total Heating Capacity	Comp. Motor Input
	kBtuh	kW	kBtuh	kW	kBtuh	kW	kBtuh	kW	kBtuh	kW
4160	190.6	10.10	136.1	8.83	94.7	7.92	61.7	7.09	37.5	6.62
5200	196.3	9.32	139.6	8.27	96.6	7.53	63.1	6.86	38.6	6.56
6240	200.3	8.82	142.3	7.92	98.4	7.30	64.5	6.73	39.7	6.55

# COOLING/HEATING RATINGS

NOTE – For Temperatures and Capacities not shown in tables, see bulletin – Cooling Unit Rating Table Correction Factor Data in Miscellaneous Engineering Data section.

## 15 TON - COOLING LDT180H4M (1 COMPRESSOR - PART LOAD)

Entering Wet Bulb Temperature	Total Air Volume	Outdoor Air Temperature Entering Outdoor Coil																			
		65°F					75°F					85°F					95°F				
		Total Cool Cap.	Comp. Motor Input	Sensible To Total Ratio (S/T) Dry Bulb			Total Cool Cap.	Comp. Motor Input	Sensible To Total Ratio (S/T) Dry Bulb			Total Cool Cap.	Comp. Motor Input	Sensible To Total Ratio (S/T) Dry Bulb			Total Cool Cap.	Comp. Motor Input	Sensible To Total Ratio (S/T) Dry Bulb		
				75°F	80°F	85°F			75°F	80°F	85°F			75°F	80°F	85°F			75°F	80°F	85°F
cfm	kBtuh	kW	75°F	80°F	85°F	kBtuh	kW	75°F	80°F	85°F	kBtuh	kW	75°F	80°F	85°F	kBtuh	kW	75°F	80°F	85°F	
63°F	2000	64.3	2.43	0.76	0.94	1	60.6	2.67	0.77	0.98	1	56.8	2.96	0.79	1	1	52.9	3.32	0.81	1	1
	2400	67.1	2.46	0.82	1	1	63.6	2.69	0.83	1	1	60.1	2.98	0.86	1	1	56	3.33	0.89	1	1
	2800	70.3	2.49	0.88	1	1	66.8	2.71	0.91	1	1	63.2	2.99	0.95	1	1	58.7	3.34	0.99	1	1
67°F	2000	68.9	2.47	0.57	0.73	0.9	65	2.7	0.57	0.74	0.93	60.9	2.98	0.58	0.76	0.96	56.3	3.33	0.58	0.78	1
	2400	71.2	2.49	0.61	0.79	1	67.3	2.71	0.61	0.81	1	63.1	2.99	0.62	0.83	1	58.4	3.34	0.63	0.86	1
	2800	73.1	2.51	0.64	0.85	1	69.2	2.72	0.65	0.88	1	65	3	0.67	0.91	1	59.9	3.34	0.68	0.96	1
71°F	2000	73.8	2.52	0.4	0.56	0.71	69.9	2.73	0.39	0.56	0.72	65.7	3	0.39	0.56	0.73	60.8	3.34	0.38	0.57	0.75
	2400	76.1	2.54	0.41	0.59	0.77	72.2	2.75	0.41	0.6	0.78	67.9	3.02	0.41	0.61	0.81	62.7	3.35	0.41	0.62	0.84
	2800	77.9	2.56	0.43	0.63	0.83	73.8	2.76	0.43	0.64	0.85	69	3.02	0.43	0.66	0.88	64.1	3.36	0.43	0.68	0.93

## 15 TON - COOLING LDT180H4M (2 COMPRESSORS - PART LOAD / FULL LOAD)

Entering Wet Bulb Temperature	Total Air Volume	Outdoor Air Temperature Entering Outdoor Coil																			
		85°F					95°F					105°F					115°F				
		Total Cool Cap.	Comp. Motor Input	Sensible To Total Ratio (S/T) Dry Bulb			Total Cool Cap.	Comp. Motor Input	Sensible To Total Ratio (S/T) Dry Bulb			Total Cool Cap.	Comp. Motor Input	Sensible To Total Ratio (S/T) Dry Bulb			Total Cool Cap.	Comp. Motor Input	Sensible To Total Ratio (S/T) Dry Bulb		
				75°F	80°F	85°F			75°F	80°F	85°F			75°F	80°F	85°F			75°F	80°F	85°F
cfm	kBtuh	kW	75°F	80°F	85°F	kBtuh	kW	75°F	80°F	85°F	kBtuh	kW	75°F	80°F	85°F	kBtuh	kW	75°F	80°F	85°F	
63°F	3300	138	8.46	0.67	0.81	0.92	129.3	9.47	0.68	0.82	0.94	119.4	10.93	0.69	0.84	0.95	109.6	11.93	0.7	0.86	0.97
	4000	146.3	8.54	0.72	0.87	0.97	136.9	9.52	0.73	0.89	0.99	126.8	10.99	0.74	0.9	1	116.6	11.97	0.76	0.92	1
	4800	154.2	8.62	0.77	0.92	1	143.9	9.58	0.79	0.94	1	133.6	11.05	0.81	0.96	1	123	12.39	0.83	0.97	1
67°F	3300	149	8.56	0.52	0.65	0.77	139.5	9.54	0.52	0.66	0.79	127.3	10.66	0.52	0.67	0.81	117.8	11.98	0.52	0.68	0.83
	4000	157.2	8.64	0.55	0.69	0.84	146.8	9.61	0.55	0.71	0.85	136	10.73	0.55	0.72	0.87	124.5	12.03	0.56	0.74	0.89
	4800	164.1	8.72	0.58	0.75	0.9	152.9	9.67	0.59	0.76	0.91	141.8	10.78	0.59	0.78	0.93	129.6	12.45	0.6	0.81	0.95
71°F	3300	160.1	8.66	0.39	0.51	0.63	149.6	9.63	0.38	0.51	0.63	139.4	10.75	0.37	0.51	0.64	127.6	12.43	0.36	0.51	0.66
	4000	167.5	8.74	0.4	0.54	0.67	157.3	9.7	0.4	0.54	0.68	146.4	10.81	0.39	0.54	0.7	132.1	12.49	0.38	0.55	0.72
	4800	174.8	8.82	0.42	0.57	0.72	164.2	9.77	0.41	0.58	0.74	152.6	10.87	0.41	0.58	0.76	140.6	12.15	0.4	0.59	0.79

## 15 TON - COOLING LDT180H4M (2 COMPRESSORS - FULL LOAD)

Entering Wet Bulb Temperature	Total Air Volume	Outdoor Air Temperature Entering Outdoor Coil																			
		85°F					95°F					105°F					115°F				
		Total Cool Cap.	Comp. Motor Input	Sensible To Total Ratio (S/T) Dry Bulb			Total Cool Cap.	Comp. Motor Input	Sensible To Total Ratio (S/T) Dry Bulb			Total Cool Cap.	Comp. Motor Input	Sensible To Total Ratio (S/T) Dry Bulb			Total Cool Cap.	Comp. Motor Input	Sensible To Total Ratio (S/T) Dry Bulb		
				75°F	80°F	85°F			75°F	80°F	85°F			75°F	80°F	85°F			75°F	80°F	85°F
cfm	kBtuh	kW	75°F	80°F	85°F	kBtuh	kW	75°F	80°F	85°F	kBtuh	kW	75°F	80°F	85°F	kBtuh	kW	75°F	80°F	85°F	
63°F	4800	176.1	10.46	0.72	0.87	1	165	11.67	0.73	0.89	1	153	13.07	0.74	0.91	1	140.1	15.42	0.77	0.94	1
	6000	185.8	10.55	0.78	0.95	1	174	11.75	0.79	0.97	1	161.8	13.16	0.82	0.99	1	150.7	15.45	0.84	1	1
	7200	193.4	10.62	0.84	1	1	182.4	11.83	0.86	1	1	170.9	13.22	0.88	1	1	156.5	15.46	0.91	1	1
67°F	4800	188.5	10.58	0.56	0.7	0.83	177.3	11.78	0.56	0.71	0.85	164.5	13.17	0.56	0.72	0.88	152.9	15.45	0.57	0.74	0.91
	6000	197.8	10.66	0.59	0.76	0.91	185.7	11.87	0.6	0.77	0.94	172.5	13.24	0.61	0.79	0.97	155.8	15.46	0.62	0.83	1
	7200	204.2	10.74	0.63	0.82	0.98	192.1	11.92	0.64	0.84	1	175	13.84	0.65	0.87	1	165.4	15.48	0.66	0.89	1
71°F	4800	201.2	10.71	0.41	0.54	0.67	189.3	11.89	0.41	0.55	0.68	176.3	13.27	0.4	0.55	0.7	164.4	15.47	0.4	0.56	0.71
	6000	210.5	10.8	0.43	0.58	0.73	198.4	12	0.43	0.59	0.75	183.5	13.87	0.42	0.6	0.78	172.9	15.53	0.42	0.61	0.79
	7200	217.1	10.97	0.44	0.62	0.79	204.7	12.07	0.44	0.63	0.82	193.3	13.93	0.44	0.64	0.83	177.6	15.58	0.44	0.66	0.87

## 15 TON - HEATING LDT180H4M

Indoor Coil Air Volume 70°F Dry Bulb cfm	Air Temperature Entering Outdoor Coil									
	65°F		45°F		25°F		5°F		-15°F	
	Total Heating Capacity	Comp. Motor Input	Total Heating Capacity	Comp. Motor Input	Total Heating Capacity	Comp. Motor Input	Total Heating Capacity	Comp. Motor Input	Total Heating Capacity	Comp. Motor Input
	kBtuh	kW	kBtuh	kW	kBtuh	kW	kBtuh	kW	kBtuh	kW
4800	232.5	12.63	165.3	11.38	112.0	10.27	74.7	9.51	45.8	8.73
6000	240.4	11.67	170.7	10.68	115.5	9.76	77.1	9.17	47.7	8.58
7200	247.5	11.08	175.1	10.22	118.8	9.45	79.9	8.95	49.9	8.51



## COOLING/HEATING RATINGS

NOTE – For Temperatures and Capacities not shown in tables, see bulletin – Cooling Unit Rating Table Correction Factor Data in Miscellaneous Engineering Data section.

### 20 TON - COOLING LDT240H4M (1 COMPRESSOR - PART LOAD)

Entering Wet Bulb Temperature	Total Air Volume	Outdoor Air Temperature Entering Outdoor Coil																			
		65°F					75°F					85°F					95°F				
		Total Cool Cap.	Comp. Motor Input	Sensible To Total Ratio (S/T) Dry Bulb			Total Cool Cap.	Comp. Motor Input	Sensible To Total Ratio (S/T) Dry Bulb			Total Cool Cap.	Comp. Motor Input	Sensible To Total Ratio (S/T) Dry Bulb			Total Cool Cap.	Comp. Motor Input	Sensible To Total Ratio (S/T) Dry Bulb		
				75°F	80°F	85°F			75°F	80°F	85°F			75°F	80°F	85°F			75°F	80°F	85°F
cfm	kBtuh	kW	75°F	80°F	85°F	kBtuh	kW	75°F	80°F	85°F	kBtuh	kW	75°F	80°F	85°F	kBtuh	kW	75°F	80°F	85°F	
63°F	3200	92.2	3.35	0.82	1	1	86.6	3.91	0.84	1	1	80.4	4.54	0.86	1	1	73.9	5.26	0.89	1	1
	4000	98	3.33	0.9	1	1	92.4	3.88	0.93	1	1	86	4.52	0.96	1	1	79.4	5.23	0.99	1	1
	4800	102.7	3.32	0.98	1	1	96.6	3.87	1	1	1	90.2	4.5	1	1	1	83.7	5.21	1	1	1
67°F	3200	98.3	3.33	0.61	0.8	0.98	92.3	3.88	0.61	0.81	0.99	85.1	4.53	0.62	0.84	1	77.8	5.24	0.62	0.86	1
	4000	102.1	3.32	0.66	0.88	1	95.5	3.87	0.66	0.9	1	88.9	4.51	0.68	0.93	1	81.4	5.22	0.7	0.97	1
	4800	105	3.32	0.71	0.96	1	98.6	3.87	0.73	0.98	1	91.4	4.5	0.75	1	1	84.2	5.21	0.77	1	1
71°F	3200	105.1	3.32	0.41	0.6	0.77	98.7	3.87	0.41	0.6	0.78	91.5	4.5	0.4	0.61	0.81	84.3	5.21	0.39	0.62	0.84
	4000	108.7	3.31	0.44	0.66	0.86	102.1	3.86	0.43	0.66	0.88	94.8	4.48	0.43	0.68	0.91	87.3	5.2	0.42	0.69	0.95
	4800	111.5	3.31	0.46	0.71	0.94	104.6	3.85	0.46	0.73	0.97	97.1	4.47	0.46	0.75	0.99	89.6	5.19	0.46	0.77	1

### 20 TON - COOLING LDT240H4M (2 COMPRESSORS - PART LOAD / FULL LOAD)

Entering Wet Bulb Temperature	Total Air Volume	Outdoor Air Temperature Entering Outdoor Coil																			
		85°F					95°F					105°F					115°F				
		Total Cool Cap.	Comp. Motor Input	Sensible To Total Ratio (S/T) Dry Bulb			Total Cool Cap.	Comp. Motor Input	Sensible To Total Ratio (S/T) Dry Bulb			Total Cool Cap.	Comp. Motor Input	Sensible To Total Ratio (S/T) Dry Bulb			Total Cool Cap.	Comp. Motor Input	Sensible To Total Ratio (S/T) Dry Bulb		
				75°F	80°F	85°F			75°F	80°F	85°F			75°F	80°F	85°F			75°F	80°F	85°F
cfm	kBtuh	kW	75°F	80°F	85°F	kBtuh	kW	75°F	80°F	85°F	kBtuh	kW	75°F	80°F	85°F	kBtuh	kW	75°F	80°F	85°F	
63°F	4800	182.4	11.6	0.7	0.85	0.96	165.7	13.2	0.7	0.87	0.97	151.9	14.91	0.72	0.89	0.99	135.8	16.9	0.73	0.91	1
	6000	194.3	11.61	0.76	0.92	1	182.6	13.23	0.77	0.93	1	162.7	14.94	0.79	0.95	1	146.7	16.92	0.82	0.97	1
	7200	202.9	11.63	0.81	0.97	1	188.4	13.26	0.84	0.98	1	172.8	14.97	0.86	1	1	156	16.94	0.89	1	1
67°F	4800	197.2	11.62	0.54	0.67	0.81	181.3	13.21	0.53	0.68	0.83	164.8	14.95	0.53	0.69	0.85	148.3	16.94	0.52	0.71	0.88
	6000	208.2	11.63	0.57	0.74	0.89	192.1	13.24	0.57	0.75	0.91	174.6	14.99	0.58	0.77	0.93	157.1	16.98	0.58	0.79	0.95
	7200	217.1	11.65	0.61	0.79	0.95	200.2	13.26	0.62	0.81	0.96	182.2	15.01	0.62	0.84	0.98	162.9	16.99	0.63	0.87	1
71°F	4800	212.2	11.63	0.39	0.52	0.65	195.7	13.24	0.38	0.52	0.66	179.8	14.99	0.37	0.52	0.67	162.3	16.97	0.35	0.52	0.69
	6000	223.8	11.66	0.41	0.56	0.71	207.2	13.26	0.4	0.57	0.73	189.6	15.03	0.39	0.57	0.75	170.4	17	0.38	0.58	0.77
	7200	232	11.67	0.43	0.6	0.77	214.7	13.28	0.42	0.61	0.79	196.7	15.05	0.41	0.62	0.82	176.7	17.02	0.4	0.63	0.85

### 20 TON - COOLING LDT240H4M (2 COMPRESSORS - FULL LOAD)

Entering Wet Bulb Temperature	Total Air Volume	Outdoor Air Temperature Entering Outdoor Coil																			
		85°F					95°F					105°F					115°F				
		Total Cool Cap.	Comp. Motor Input	Sensible To Total Ratio (S/T) Dry Bulb			Total Cool Cap.	Comp. Motor Input	Sensible To Total Ratio (S/T) Dry Bulb			Total Cool Cap.	Comp. Motor Input	Sensible To Total Ratio (S/T) Dry Bulb			Total Cool Cap.	Comp. Motor Input	Sensible To Total Ratio (S/T) Dry Bulb		
				75°F	80°F	85°F			75°F	80°F	85°F			75°F	80°F	85°F			75°F	80°F	85°F
cfm	kBtuh	kW	75°F	80°F	85°F	kBtuh	kW	75°F	80°F	85°F	kBtuh	kW	75°F	80°F	85°F	kBtuh	kW	75°F	80°F	85°F	
63°F	6400	229.1	14.17	0.73	0.88	1	212.2	15.82	0.73	0.9	1	195.8	17.66	0.75	0.93	1	178.9	19.73	0.77	0.96	1
	8000	241.1	14.3	0.79	0.96	1	223.9	15.94	0.81	0.99	1	207.6	17.78	0.83	1	1	190.5	19.86	0.85	1	1
	9600	253	14.41	0.85	1	1	236.1	16.07	0.87	1	1	220.6	17.93	0.9	1	1	202.9	20	0.93	1	1
67°F	6400	245.8	14.34	0.56	0.7	0.85	228.6	15.99	0.55	0.71	0.87	210.9	17.83	0.55	0.73	0.89	192.7	19.89	0.56	0.74	0.92
	8000	259	14.47	0.59	0.77	0.93	240	16.11	0.6	0.78	0.96	221.3	17.94	0.6	0.81	0.98	201.9	19.99	0.61	0.83	1
	9600	266.6	14.55	0.63	0.83	0.99	249	16.2	0.64	0.85	1	229.2	18.03	0.65	0.88	1	208.7	20.07	0.66	0.91	1
71°F	6400	262.7	14.51	0.41	0.54	0.68	245.3	16.16	0.4	0.55	0.69	227.2	18	0.39	0.55	0.7	208.2	20.06	0.38	0.55	0.72
	8000	276.4	14.64	0.42	0.59	0.74	257.4	16.29	0.42	0.59	0.76	237.7	18.11	0.41	0.6	0.78	217.1	20.16	0.4	0.61	0.81
	9600	284.9	14.72	0.44	0.63	0.81	264.8	16.36	0.44	0.64	0.83	245.5	18.19	0.43	0.65	0.86	224.5	20.24	0.43	0.66	0.89

### 20 TON - HEATING LDT240H4M

Indoor Coil Air Volume 70°F Dry Bulb cfm	Air Temperature Entering Outdoor Coil									
	65°F		45°F		25°F		5°F		-15°F	
	Total Heating Capacity	Comp. Motor Input	Total Heating Capacity	Comp. Motor Input	Total Heating Capacity	Comp. Motor Input	Total Heating Capacity	Comp. Motor Input	Total Heating Capacity	Comp. Motor Input
6400	290.0	16.08	210.2	14.43	146.5	12.97	99.7	11.98	64.5	11.46
8000	297.6	14.90	214.6	13.58	149.5	12.39	102.0	11.62	66.3	11.36
9600	308.2	14.16	223.5	13.09	156.1	12.02	107.7	11.42	71.5	11.32

## BLOWER DATA

BLOWER TABLE INCLUDES RESISTANCE FOR BASE UNIT ONLY WITH DRY INDOOR COIL & AIR FILTERS IN PLACE FOR ALL UNITS ADD:

- 1 - Wet indoor coil air resistance of selected unit.
- 2 - Any factory installed options air resistance (heat section, economizer, etc.)
- 3 - Any field installed accessories air resistance (heat section, duct resistance, diffuser, etc.)

Then determine from blower table blower motor output and drive required.  
See page 27 for wet coil, option/accessory air resistance data, and factory installed drive kit specifications.

### Minimum Air Volume Required For Different Gas Heat Sizes:

Low Heat - 3000 cfm | Standard and Medium Heat - 4500 cfm | High Heat - 5125 cfm

Air Volume cfm	TOTAL STATIC PRESSURE - Inches Water Gauge (Pa)																									
	0.20		0.40		0.60		0.80		1.00		1.20		1.40		1.60		1.80		2.00		2.20		2.40		2.60	
	RPM	BHP	RPM	BHP	RPM	BHP	RPM	BHP	RPM	BHP	RPM	BHP	RPM	BHP	RPM	BHP	RPM	BHP	RPM	BHP	RPM	BHP	RPM	BHP	RPM	BHP
2750	385	0.30	505	0.50	600	0.70	680	0.90	755	1.10	820	1.30	885	1.50	950	1.70	1005	1.90	1060	2.10	1110	2.30	1160	2.50	1210	2.70
3000	395	0.35	515	0.55	610	0.75	685	1.00	760	1.20	825	1.45	885	1.70	950	1.95	1010	2.20	1070	2.45	1130	2.70	1190	3.00	1250	3.25
3250	405	0.40	520	0.60	615	0.85	695	1.10	765	1.30	830	1.60	890	1.85	950	2.10	970	2.30	1030	2.55	1090	2.80	1150	3.05	1210	3.30
3500	415	0.45	530	0.70	620	0.95	700	1.20	775	1.45	840	1.75	900	2.00	960	2.25	1020	2.50	1080	2.75	1140	3.00	1200	3.25	1260	3.50
3750	425	0.50	540	0.75	630	1.05	710	1.30	780	1.60	845	1.90	905	2.15	965	2.40	1025	2.65	1085	2.90	1145	3.15	1205	3.40	1265	3.65
4000	435	0.55	545	0.85	635	1.10	715	1.40	785	1.70	850	2.00	910	2.25	970	2.50	1030	2.75	1090	3.00	1150	3.25	1210	3.50	1270	3.75
4250	445	0.60	555	0.90	645	1.25	725	1.55	795	1.85	855	2.15	915	2.40	975	2.65	1035	2.90	1095	3.15	1155	3.40	1215	3.65	1275	3.90
4500	455	0.70	565	1.00	655	1.35	730	1.65	800	2.00	865	2.35	925	2.60	985	2.85	1045	3.10	1105	3.35	1165	3.60	1225	3.85	1285	4.10
4750	470	0.75	575	1.10	660	1.45	740	1.80	810	2.15	870	2.50	930	2.75	990	3.00	1050	3.25	1110	3.50	1170	3.75	1230	4.00	1290	4.25
5000	480	0.85	585	1.25	670	1.60	750	1.95	815	2.30	880	2.70	940	3.00	1000	3.25	1060	3.50	1120	3.75	1180	4.00	1240	4.25	1300	4.50
5250	495	0.95	595	1.35	680	1.70	755	2.10	825	2.50	890	2.90	950	3.25	1010	3.50	1070	3.75	1130	4.00	1190	4.25	1250	4.50	1310	4.75
5500	505	1.05	605	1.45	690	1.85	765	2.25	835	2.65	895	3.05	955	3.35	1015	3.65	1075	3.90	1135	4.15	1195	4.40	1255	4.65	1315	4.90
5750	520	1.15	615	1.60	700	2.00	775	2.45	840	2.85	905	3.25	965	3.55	1025	3.85	1085	4.10	1145	4.35	1205	4.60	1265	4.85	1325	5.10
6000	530	1.30	630	1.75	710	2.15	785	2.60	850	3.05	910	3.45	970	3.75	1030	4.05	1090	4.30	1150	4.55	1210	4.80	1270	5.05	1330	5.30
6250	545	1.40	640	1.90	720	2.35	795	2.80	860	3.25	920	3.70	975	4.05	1035	4.35	1095	4.60	1155	4.85	1215	5.10	1275	5.35	1335	5.60
6500	560	1.55	650	2.05	730	2.50	805	3.00	870	3.45	930	3.95	985	4.25	1045	4.55	1105	4.80	1165	5.05	1225	5.30	1285	5.55	1345	5.80
6750	570	1.70	665	2.20	745	2.70	815	3.20	880	3.70	940	4.20	995	4.50	1055	4.80	1115	5.05	1175	5.30	1235	5.55	1295	5.80	1355	6.05
7000	585	1.85	675	2.35	755	2.90	825	3.40	890	3.95	950	4.45	1005	4.75	1065	5.05	1125	5.30	1185	5.55	1245	5.80	1305	6.05	1365	6.30
7250	600	2.00	690	2.60	765	3.10	835	3.65	900	4.15	955	4.65	1015	4.95	1075	5.25	1135	5.55	1195	5.80	1255	6.05	1315	6.30	1375	6.55
7500	615	2.20	700	2.75	775	3.30	845	3.85	910	4.45	965	4.95	1020	5.25	1080	5.55	1140	5.85	1200	6.10	1260	6.35	1320	6.60	1380	6.85
7750	630	2.40	715	3.00	790	3.55	855	4.10	920	4.70	975	5.25	1030	5.55	1090	5.85	1150	6.15	1210	6.40	1270	6.65	1330	6.90	1390	7.15
8000	640	2.55	725	3.20	800	3.80	865	4.35	930	4.95	985	5.50	1040	5.80	1100	6.10	1160	6.40	1220	6.65	1280	6.90	1340	7.15	1400	7.40
8250	655	2.80	740	3.40	810	4.00	880	4.65	940	5.25	995	5.85	1050	6.10	1110	6.40	1170	6.70	1230	6.95	1290	7.20	1350	7.45	1410	7.70
8500	670	3.00	750	3.65	825	4.30	890	4.90	950	5.55	1005	6.15	1060	6.40	1120	6.70	1180	7.00	1240	7.25	1300	7.50	1360	7.75	1420	8.00
8750	685	3.25	765	3.90	835	4.55	900	5.20	960	5.85	1015	6.45	1070	6.70	1130	7.00	1190	7.30	1250	7.55	1310	7.80	1370	8.05	1430	8.30
9000	700	3.50	780	4.20	850	4.85	910	5.50	970	6.15	1025	6.80	1080	7.05	1140	7.35	1200	7.65	1260	7.90	1320	8.15	1380	8.40	1440	8.65
9250	715	3.75	790	4.45	860	5.15	925	5.85	985	6.55	1040	7.20	1095	7.50	1155	7.75	1215	8.05	1275	8.30	1335	8.55	1395	8.80	1455	9.05
9500	730	4.00	805	4.75	875	5.45	935	6.15	995	6.90	1050	7.60	1105	7.85	1165	8.10	1225	8.40	1285	8.65	1345	8.90	1405	9.15	1465	9.40
9750	745	4.30	820	5.05	885	5.75	950	6.55	1005	7.20	1060	7.95	1115	8.20	1175	8.45	1235	8.70	1295	8.95	1355	9.20	1415	9.45	1475	9.70
10,000	760	4.60	835	5.40	900	6.15	960	6.85	1015	7.60	1070	8.35	1120	8.60	1180	8.85	1240	9.10	1300	9.35	1360	9.60	1420	9.85	1480	10.10
10,250	775	4.90	845	5.65	910	6.45	970	7.20	1030	8.00	1080	8.75	1135	9.00	1195	9.25	1255	9.50	1315	9.75	1375	10.00	1435	10.25	1495	10.50
10,500	790	5.20	860	6.00	925	6.85	985	7.65	1040	8.40	1095	9.20	1145	9.45	1205	9.70	1265	10.00	1325	10.25	1385	10.50	1445	10.75	1505	11.00
10,750	805	5.55	875	6.40	940	7.25	1000	8.05	1055	8.85	1105	9.65	1155	9.90	1215	10.15	1275	10.45	1335	10.70	1395	11.00	1455	11.25	1515	11.50
11,000	820	5.90	890	6.80	950	7.60	1010	8.45	1065	9.30	1115	10.05	1165	10.30	1225	10.55	1285	10.80	1345	11.10	1405	11.40	1465	11.70	1525	12.00

## BLOWER DATA

### FACTORY INSTALLED BELT DRIVE KIT SPECIFICATIONS

Nominal hp	Maximum hp	Drive Kit Number	RPM Range
3	3.45	1	535 - 725
3	3.45	2	710 - 965
5	5.75	3	685 - 856
5	5.75	4	850 - 1045
5	5.75	5	945 - 1185
7.5	8.63	6	850 - 1045
7.5	8.63	7	945 - 1185
7.5	8.63	8	1045 - 1285
10	11.50	7	945 - 1185
10	11.50	10	1045 - 1285
10	11.50	11	1135 - 1365

NOTE - Using total air volume and system static pressure requirements determine from blower performance tables rpm and motor output required. Maximum usable output of motors furnished are shown. In Canada, nominal motor output is also maximum usable motor output. If motors of comparable output are used, be sure to keep within the service factor limitations outlined on the motor nameplate.

NOTE - Motor service factor limit - 1.0

### FACTORY INSTALLED OPTIONS/FIELD INSTALLED ACCESSORY AIR RESISTANCE

Air Volume cfm	Wet Indoor Coil	Gas Heat Exchanger			Economizer	Filters			Horizontal Roof Curb
		Low/Standard Heat	Medium Heat	High Heat		MERV 8	MERV 13	MERV 16	
	in. w.g.	in. w.g.	in. w.g.	in. w.g.	in. w.g.				in. w.g.
2750	.02	.02	.04	.05	---	.01	.03	.06	.03
3000	.02	.03	.04	.05	---	.01	.03	.06	.04
3250	.03	.03	.05	.06	---	.01	.04	.07	.04
3500	.03	.03	.05	.06	---	.01	.04	.08	.05
3750	.03	.04	.06	.07	---	.01	.04	.08	.05
4000	.04	.04	.06	.07	---	.01	.04	.09	.06
4250	.04	.04	.06	.08	---	.01	.05	.10	.07
4500	.05	.05	.07	.09	---	.01	.05	.10	.07
4750	.05	.05	.08	.10	---	.02	.05	.11	.08
5000	.05	.05	.09	.11	---	.02	.06	.12	.08
5250	.06	.06	.10	.12	---	.02	.06	.12	.09
5500	.07	.06	.10	.13	---	.02	.06	.13	.10
5750	.07	.06	.11	.14	---	.02	.07	.14	.11
6000	.08	.07	.12	.15	---	.03	.07	.14	.11
6250	.08	.07	.12	.16	.01	.03	.07	.15	.12
6500	.09	.08	.13	.17	.02	.03	.08	.16	.13
6750	.10	.08	.14	.18	.03	.03	.08	.17	.14
7000	.10	.09	.15	.19	.04	.04	.08	.17	.15
7250	.11	.09	.16	.20	.05	.04	.09	.18	.16
7500	.12	.10	.17	.21	.06	.04	.09	.19	.17
8000	.13	.11	.19	.24	.09	.05	.10	.21	.19
8500	.15	.12	.20	.26	.11	.05	.10	.22	.21
9000	.16	.13	.23	.29	.14	.06	.11	.24	.24
9500	.18	.14	.25	.32	.16	.07	.12	.25	.26
10,000	.20	.16	.27	.35	.19	.07	.12	.27	.29
10,500	.22	.17	.30	.38	.22	.08	.13	.29	.31
11,000	.24	.18	.31	.40	.25	.09	.14	.30	.34

## BLOWER DATA

### POWER EXHAUST FAN PERFORMANCE

Return Air System Static Pressure	Air Volume Exhausted
in. w.g.	cfm
0.00	8630
0.05	8210
0.10	7725
0.15	7110
0.20	6470
0.25	5790
0.30	5060
0.35	4300
0.40	3510
0.45	2690
0.50	1840

### CEILING DIFFUSER AIR RESISTANCE - in. w.g.

Air Volume cfm	Step-Down Diffuser						Flush Diffuser	
	RTD11-185S			RTD11-275S			FD11-185S	FD11-275S
	2 Ends Open	1 Side/2 Ends Open	All Ends & Sides Open	2 Ends Open	1 Side/2 Ends Open	All Ends & Sides Open		
5000	.51	.44	.39	---	---	---	.27	---
5200	.56	.48	.42	---	---	---	.30	---
5400	.61	.52	.45	---	---	---	.33	---
5600	.66	.56	.48	---	---	---	.36	---
5800	.71	.59	.51	---	---	---	.39	---
6000	.76	.63	.55	.36	.31	.27	.42	.29
6200	.80	.68	.59	---	---	---	.46	---
6400	.86	.72	.63	---	---	---	.50	---
6500	---	---	---	.42	.36	.31	---	.34
6600	.92	.77	.67	---	---	---	.54	---
6800	.99	.83	.72	---	---	---	.58	---
7000	1.03	.87	.76	.49	.41	.36	.62	.40
7200	1.09	.92	.80	---	---	---	.66	---
7400	1.15	.97	.84	---	---	---	.70	---
7500	---	---	---	.51	.46	.41	---	.45
7600	1.20	1.02	.88	---	---	---	.74	---
8000	---	---	---	.59	.49	.43	---	.50
8500	---	---	---	.69	.58	.50	---	.57
9000	---	---	---	.79	.67	.58	---	.66
9500	---	---	---	.89	.75	.65	---	.74
10,000	---	---	---	1.00	.84	.73	---	.81
10,500	---	---	---	1.10	.92	.80	---	.89
11,000	---	---	---	1.21	1.01	.88	---	.96

### CEILING DIFFUSER AIR THROW DATA - ft.

Model No.	Air Volume cfm	<sup>1</sup> Effective Throw Range - ft.		Model No.	Air Volume cfm	<sup>1</sup> Effective Throw Range - ft.	
		RTD11-185S Step-Down	FD11-185S Flush			RTD11-275S Step-Down	FD11-275S Flush
156, 180	5600	39 - 49	28 - 37	240	7200	33 - 38	26 - 35
	5800	42 - 51	29 - 38		7400	35 - 40	28 - 37
	6000	44 - 54	40 - 50		7600	36 - 41	29 - 38
	6200	45 - 55	42 - 51		7800	38 - 43	40 - 50
	6400	46 - 55	43 - 52		8000	39 - 44	42 - 51
	6600	47 - 56	45 - 56		8200	41 - 46	43 - 52
					8400	43 - 49	44 - 54
					8600	44 - 50	46 - 57
					8800	47 - 55	48 - 59

<sup>1</sup> Throw is the horizontal or vertical distance an airstream travels on leaving the outlet or diffuser before the maximum velocity is reduced to 50 ft. per minute. Four sides open.

**ELECTRICAL DATA**
**13 TON**

Model No.		LDT156H4					
		208/230V - 3 Ph		460V - 3 Ph		575V - 3 Ph	
<b><sup>1</sup> Voltage - 60Hz</b>		208/230V - 3 Ph		460V - 3 Ph		575V - 3 Ph	
Compressor 1 (Non-Inverter)	Rated Load Amps	17.6		8.5		6.3	
	Locked Rotor Amps	136		66.1		55.3	
Compressor 2 (Non-Inverter)	Rated Load Amps	22.4		10.6		7.7	
	Locked Rotor Amps	149		75		54	
Outdoor Fan Motors (6)	Full Load Amps (6 Non-ECM)	2.4		1.3		1	
Power Exhaust (2) 0.33 HP	Full Load Amps	2.4		1.3		1	
	Total	4.8		2.6		2	
Service Outlet 115V GFI (amps)		15		15		20	
Indoor Blower Motor	Horsepower	3	5	3	5	3	5
	Full Load Amps	10.6	16.7	4.8	7.6	3.9	6.1
<sup>2</sup> Maximum Overcurrent Protection (MOCP)	Unit Only	90	90	40	45	30	35
	With (2) 0.33 HP Power Exhaust	90	100	45	50	35	35
<sup>3</sup> Minimum Circuit Ampacity (MCA)	Unit Only	71	77	35	38	26	29
	With (2) 0.33 HP Power Exhaust	76	82	37	40	28	31

NOTE - All units have a minimum Short Circuit Current Rating (SCCR) of 5000 amps.

<sup>1</sup> Extremes of operating range are plus and minus 10% of line voltage.

<sup>2</sup> HACR type breaker or fuse.

<sup>3</sup> Refer to National or Canadian Electrical Code manual to determine wire, fuse and disconnect size requirements.

<sup>4</sup> Factory installed circuit breaker not available.

**ELECTRICAL DATA**
**15 TON**

Model No.		LDT180H4								
		208/230V - 3 Ph			460V - 3 Ph			575V - 3 Ph		
<b><sup>1</sup> Voltage - 60Hz</b>		208/230V - 3 Ph			460V - 3 Ph			575V - 3 Ph		
Compressor 1 (Non-Inverter)	Rated Load Amps	25.3			9.6			8.4		
	Locked Rotor Amps	184			84			60		
Compressor 2 (Non-Inverter)	Rated Load Amps	25			12.2			9		
	Locked Rotor Amps	164			100			78		
Outdoor Fan Motors (6)	Full Load Amps (6 Non-ECM)	2.4			1.3			1		
Power Exhaust (2) 0.33 HP	Full Load Amps	2.4			1.3			1		
	Total	4.8			2.6			2		
Service Outlet 115V GFI (amps)		15			15			20		
Indoor Blower Motor	Horsepower	3	5	7.5	3	5	7.5	3	5	7.5
	Full Load Amps	10.6	16.7	24.2	4.8	7.6	11	3.9	6.1	9
<sup>2</sup> Maximum Overcurrent Protection (MOCP)	Unit Only	100	110	110	45	50	50	35	40	40
	With (2) 0.33 HP Power Exhaust	110	110	125	50	50	50	40	40	45
<sup>3</sup> Minimum Circuit Ampacity (MCA)	Unit Only	82	88	96	38	41	44	30	32	35
	With (2) 0.33 HP Power Exhaust	87	93	101	41	43	47	32	34	37

NOTE - All units have a minimum Short Circuit Current Rating (SCCR) of 5000 amps.

<sup>1</sup> Extremes of operating range are plus and minus 10% of line voltage.

<sup>2</sup> HACR type breaker or fuse.

<sup>3</sup> Refer to National or Canadian Electrical Code manual to determine wire, fuse and disconnect size requirements.

<sup>4</sup> Factory installed circuit breaker not available.

**ELECTRICAL DATA****20 TON****20 TON HIGH EFFICIENCY****LDT240H4**

<sup>1</sup> Voltage - 60Hz		208/230V - 3 Ph			460V - 3 Ph			575V - 3 Ph		
Compressor 1 (Non-Inverter)	Rated Load Amps	32.6			14.8			11.1		
	Locked Rotor Amps	240			130			93.7		
Compressor 2 (Non-Inverter)	Rated Load Amps	31.1			13			11		
	Locked Rotor Amps	255			123			93.7		
Outdoor Fan Motors (6)	Full Load Amps (6 Non-ECM)	2.4			1.3			1		
Power Exhaust (2) 0.33 HP	Full Load Amps	2.4			1.3			1		
	Total	4.8			2.6			2		
Service Outlet 115V GFI (amps)		15			15			20		
Indoor Blower Motor	Horsepower	5	7.5	10	5	7.5	10	5	7.5	10
	Full Load Amps	16.7	24.2	30.8	7.6	11	14	6.1	9	11
<sup>2</sup> Maximum Overcurrent Protection (MOCP)	Unit Only	125	125	125	60	60	60	45	50	50
	With (2) 0.33 HP Power Exhaust	125	125	150	60	60	70	50	50	50
<sup>3</sup> Minimum Circuit Ampacity (MCA)	Unit Only	103	111	118	47	51	54	37	40	42
	With (2) 0.33 HP Power Exhaust	108	116	122	50	53	56	39	42	44

NOTE - All units have a minimum Short Circuit Current Rating (SCCR) of 5000 amps.

<sup>1</sup> Extremes of operating range are plus and minus 10% of line voltage.<sup>2</sup> HACR type breaker or fuse.<sup>3</sup> Refer to National or Canadian Electrical Code manual to determine wire, fuse and disconnect size requirements.<sup>4</sup> Factory installed circuit breaker not available.**ELECTRICAL ACCESSORIES - DISCONNECTS****13 TON | LDT156H4**

Motor Horsepower	3		5		3		5	
	208V	240V	208V	240V	480V	480V	600V	600V
Unit Only	54W88	54W88	54W89	54W89	54W88	54W88	54W88	54W88
Unit + Power Exhaust	54W89	54W89	54W89	54W89	54W88	54W88	54W88	54W88

**15 TON | LDT180H4**

Motor Horsepower	3		5		7.5		3		5		7.5	
	208V	240V	208V	240V	208V	240V	480V	480V	480V	600V	600V	600V
Unit Only	54W89	54W89	54W89	54W89	54W89	54W89	54W88	54W88	54W88	54W88	54W88	54W88
Unit + Power Exhaust	54W89	54W89	54W89	54W89	54W89	54W89	54W88	54W88	54W88	54W88	54W88	54W88

**20 TON | LDT240H4**

Motor Horsepower	5		7.5		10		5		7.5		10	
	208V	240V	208V	240V	208V	240V	480V	480V	480V	600V	600V	600V
Unit Only	54W89	54W89	54W89	54W89	54W89	54W89	54W88	54W88	54W88	54W88	54W88	54W88
Unit + Power Exhaust	54W89	54W89	54W89	54W89	54W89	54W89	54W88	54W88	54W88	54W88	54W88	54W88

Disconnects - 54W88 - 80A  
54W89 - 150A  
90W82 - 250A

**FIELD WIRING NOTES**

- For use with copper wiring only
- Field wiring not furnished
- All wiring must conform to NEC or CEC and local electrical codes
- For specific wiring information, please refer to the installation instructions

## INSTALLATION CLEARANCES

### Unit With Economizer

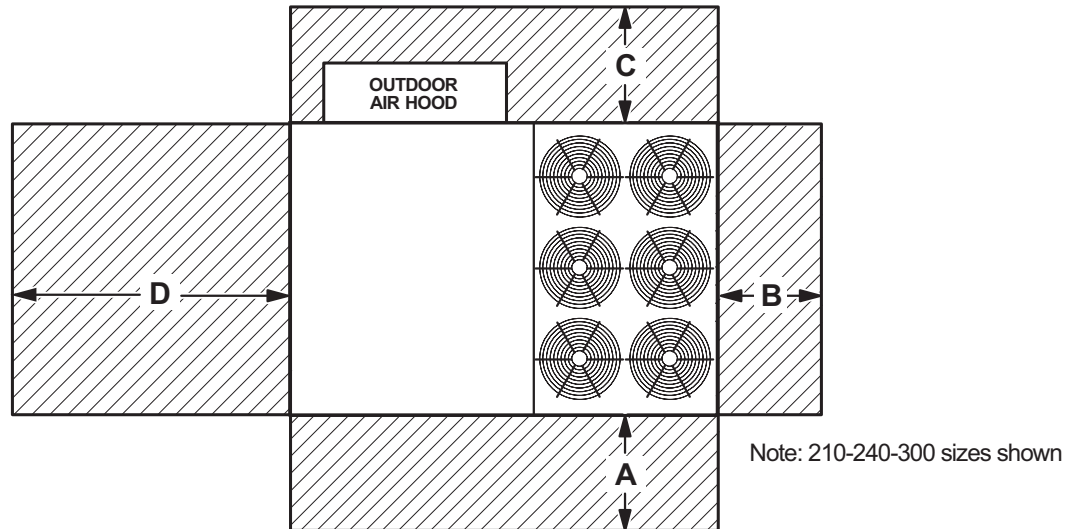

<sup>1</sup> Unit Clearance	A		B		C		D		Top Clearance
	in.	mm	in.	mm	in.	mm	in.	mm	
<b>Service Clearance</b>	60	1524	36	914	36	934	66	1676	Unobstructed
<b>Clearance to Combustibles</b>	36	914	1	25	1	25	1	25	
<b>Minimum Operation Clearance</b>	45	1143	36	914	36	914	41	1041	

NOTE - Entire perimeter of unit base requires support when elevated above the mounting surface.

<sup>1</sup> **Service Clearance** - Required for removal of serviceable parts.

**Clearance to Combustibles** - Required clearance to combustible material.

**Minimum Operation Clearance** - Required clearance for proper unit operation.

## OUTDOOR SOUND DATA

Unit Model Number	Octave Band Sound Power Levels dBA, re 10 <sup>-12</sup> Watts - Center Frequency - Hz							<sup>1</sup> Sound Rating Number (dBA)
	125	250	500	1000	2000	4000	8000	
156, 180, 240	79	84	88	89	85	82	73	94

Note - The octave sound power data does not include tonal corrections.

<sup>1</sup> Sound Rating Number according to AHRI Standard 370-2001 (includes pure tone penalty). Sound Rating Number is the overall A-Weighted Sound Power Level, (LWA), dBA (100 Hz to 10,000 Hz).

WEIGHT DATA				UNIT
Model Number	Net		Shipping	
	lbs.	kg	lbs.	kg
156 Base Unit	2358	1070	2558	1160
156 Max. Unit	2643	1199	2843	1290
180 Base Unit	2386	1082	2586	1173
180 Max. Unit	2671	1212	2871	1302
240 Base Unit	2428	1101	2628	1192
240 Max. Unit	2713	1231	2913	1321

NOTE - Max. Unit is the unit with ALL INTERNAL OPTIONS Installed. (Economizer, Standard Static Power Exhaust Fans, Controls, etc.). Does not include accessories EXTERNAL to unit.

WEIGHT DATA		OPTIONS / ACCESSORIES	
Description	Shipping Weight		
	lbs.	kg	
<b>ECONOMIZER / OUTDOOR AIR / EXHAUST</b>			
<b>Economizer</b>			
Economizer Dampers (with Outdoor Air Hood)	167	76	
Barometric Relief Dampers (downflow)	30	14	
Barometric Relief Dampers (horizontal)	20	9	
<b>Outdoor Air Dampers with Hood (downflow)</b>			
Motorized	39	18	
Manual	22	10	
<b>Power Exhaust</b>	62	28	
<b>GAS HEAT EXCHANGER (NET WEIGHT)</b>			
Medium Heat (adder over standard heat)	18	8	
High Heat (adder over standard heat)	64	29	
<b>COMBINATION COIL/HAIL GUARDS</b>			
All models	36	16	
<b>ROOF CURBS</b>			
<b>Hybrid Roof Curbs, Downflow</b>			
8 in. height	136	62	
14 in. height	169	77	
18 in. height	191	87	
24 in. height	224	102	
<b>Adjustable Pitch Curb, Downflow</b>			
14 in. height	224	102	
<b>Horizontal, Standard</b>			
26 in. height			
37 in. height			
<b>CEILING DIFFUSERS</b>			
Step-Down	RTD11-185S	168	76
	RTD11-275S	238	108
Flush	FD11-185S	168	76
	FD11-275S	238	108
Transitions	C1DIFF33C-1	80	36
	C1DIFF34C-1	75	34



# DIMENSIONS - UNIT

CORNER WEIGHTS									CENTER OF GRAVITY			
Model No.	AA		BB		CC		DD		EE		FF	
	lbs.	kg	lbs.	kg	lbs.	kg	lbs.	kg	in.	mm	in.	mm
LDT156 Base Unit	452	205	506	230	739	336	660	300	57	1446	37	941
LDT156 Max. Unit	558	254	598	272	769	350	718	326	55-3/4	1416	39-7/8	1012
LDT180 Base Unit	453	206	508	231	753	342	672	306	57	1448	36-3/4	933
LDT180 Max. Unit	559	254	599	272	783	356	730	332	55-3/4	1416	39-1/2	1003
LDT240 Base Unit	456	207	509	232	772	351	691	314	56-7/8	1444	36-1/4	921
LDT240 Max. Unit	561	255	601	273	802	364	749	340	55-3/4	1416	39	991

Base Unit - The unit with NO INTERNAL OPTIONS.

Max. Unit - The unit with ALL INTERNAL OPTIONS Installed. (Economizer, Standard Static Power Exhaust Fans, Controls, etc.). Does not include accessories external to unit.

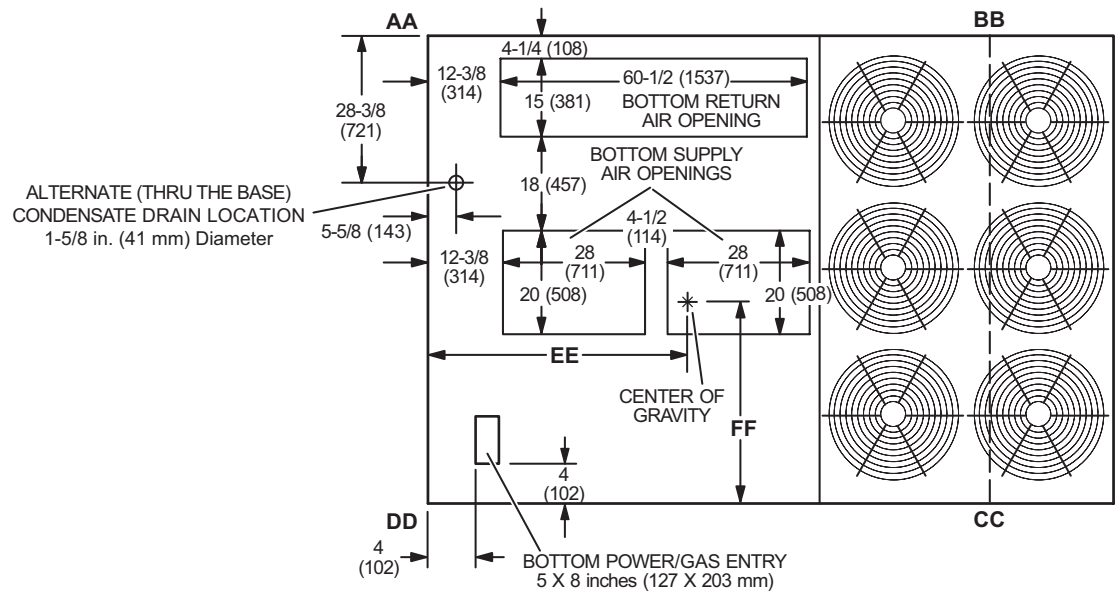

**TOP VIEW**

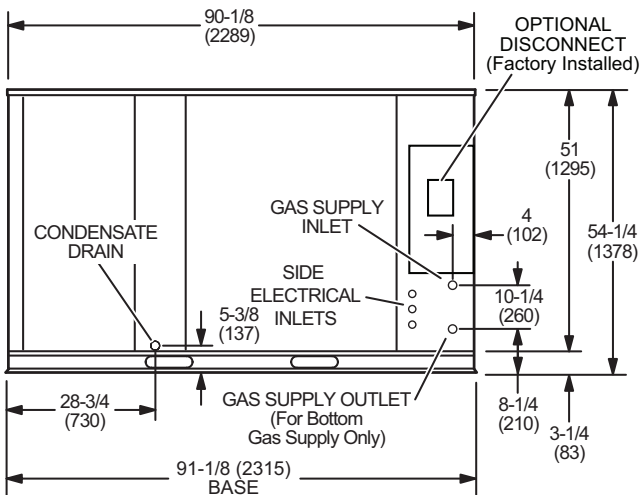

**END VIEW**

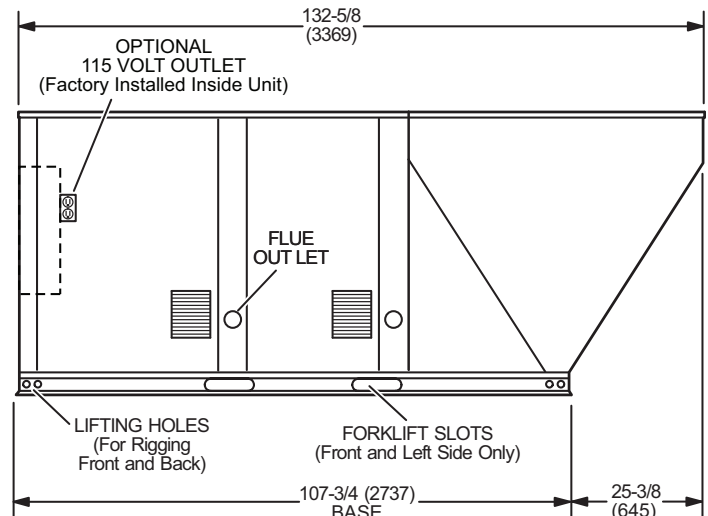

**SIDE VIEW**

**OUTDOOR AIR HOOD DETAIL**

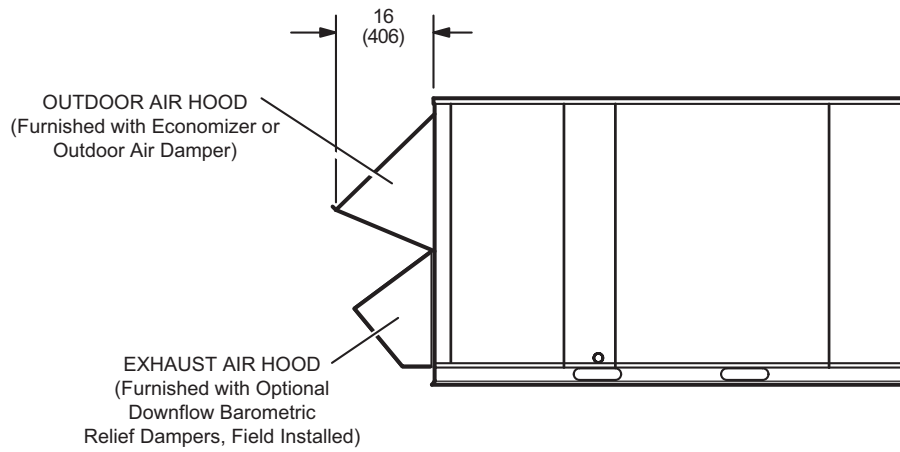

**OPTIONAL HORIZONTAL BAROMETRIC RELIEF DAMPERS WITH HOOD**

(Field installed in horizontal return air duct adjacent to unit)

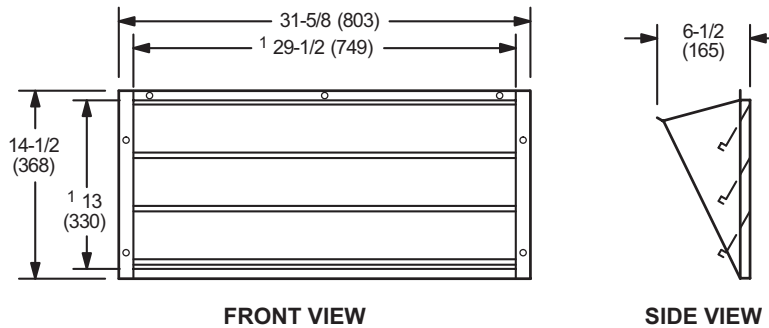

NOTE - Two furnished per order no.  
<sup>1</sup> NOTE - Opening size required in return air duct.

**HYBRID ROOF CURBS - DOUBLE DUCT OPENING**

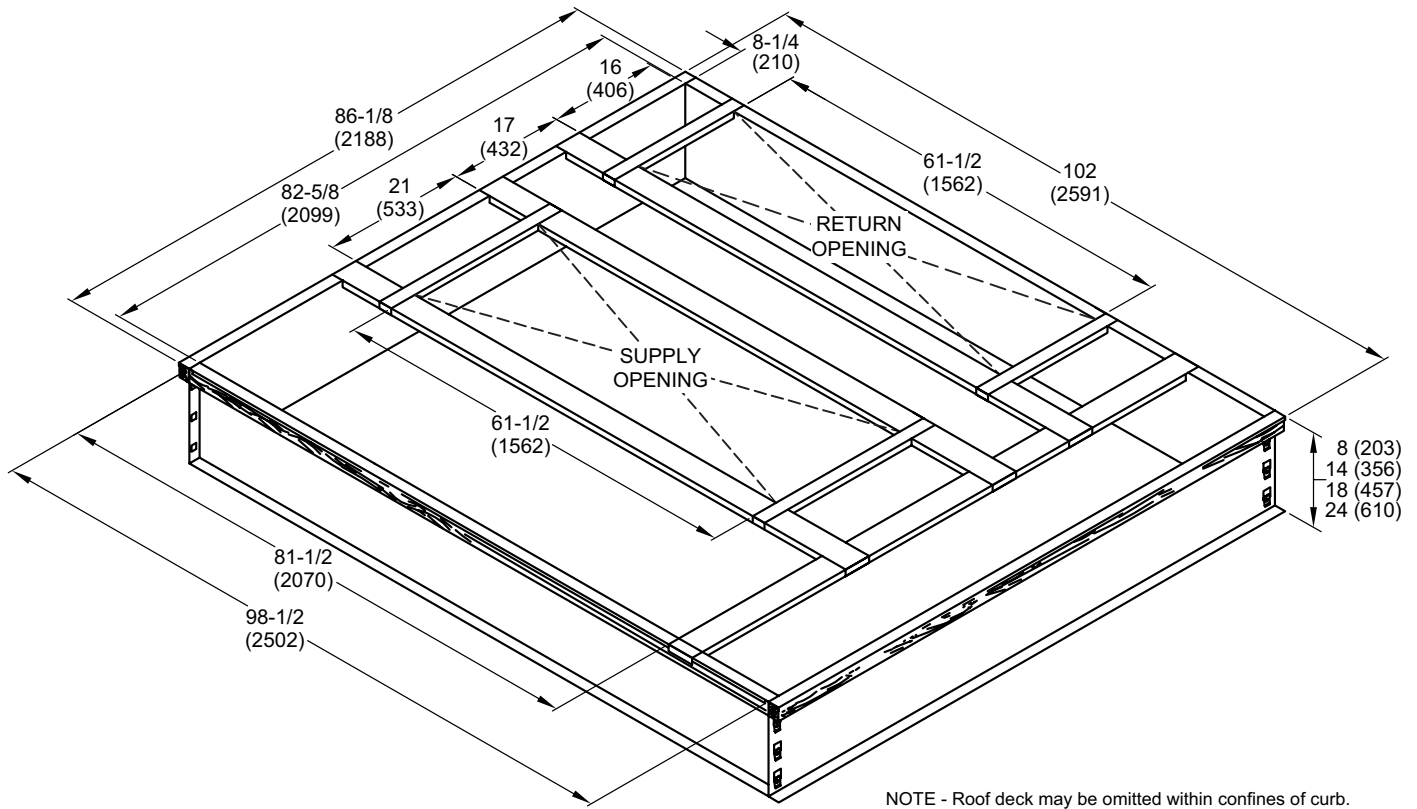

**TYPICAL FLASHING DETAIL FOR ROOF CURB**

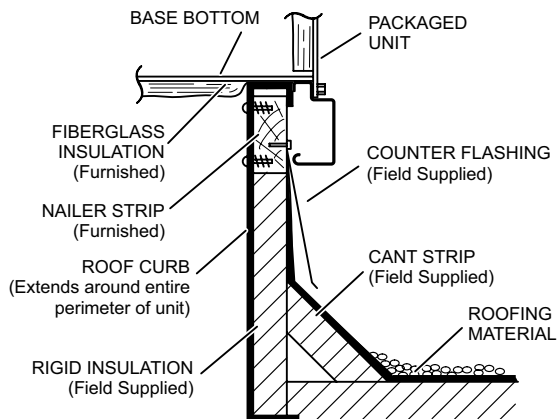

**DETAIL ROOF CURB**

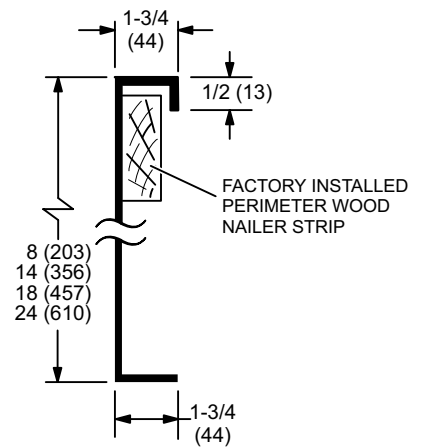



**ROOF CURBS WITH SUPPLY & RETURN AIR TRANSITIONS FOR CEILING DIFFUSERS**

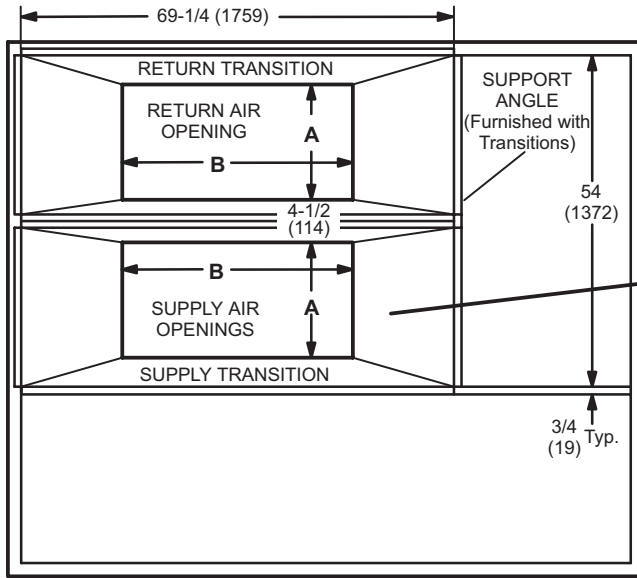

**TOP VIEW**

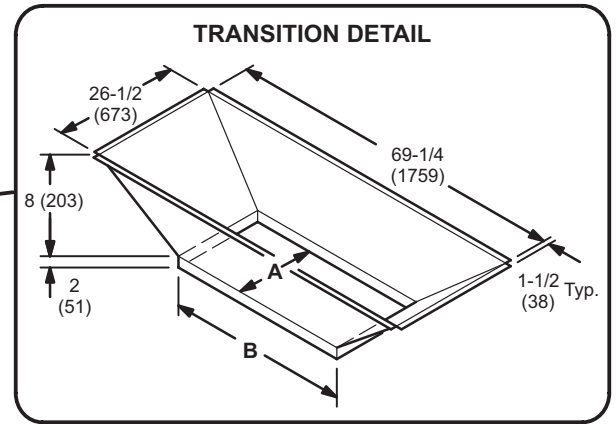

**TRANSITION OPENING SIZES**

Model Number	A		B	
	inch	mm	inch	mm
C1DIFF33C-1	18	457	36	914
C1DIFF34C-1	24	610	48	1219

**HORIZONTAL ROOF CURBS – Requires Optional Horizontal Return Air Panel Kit**

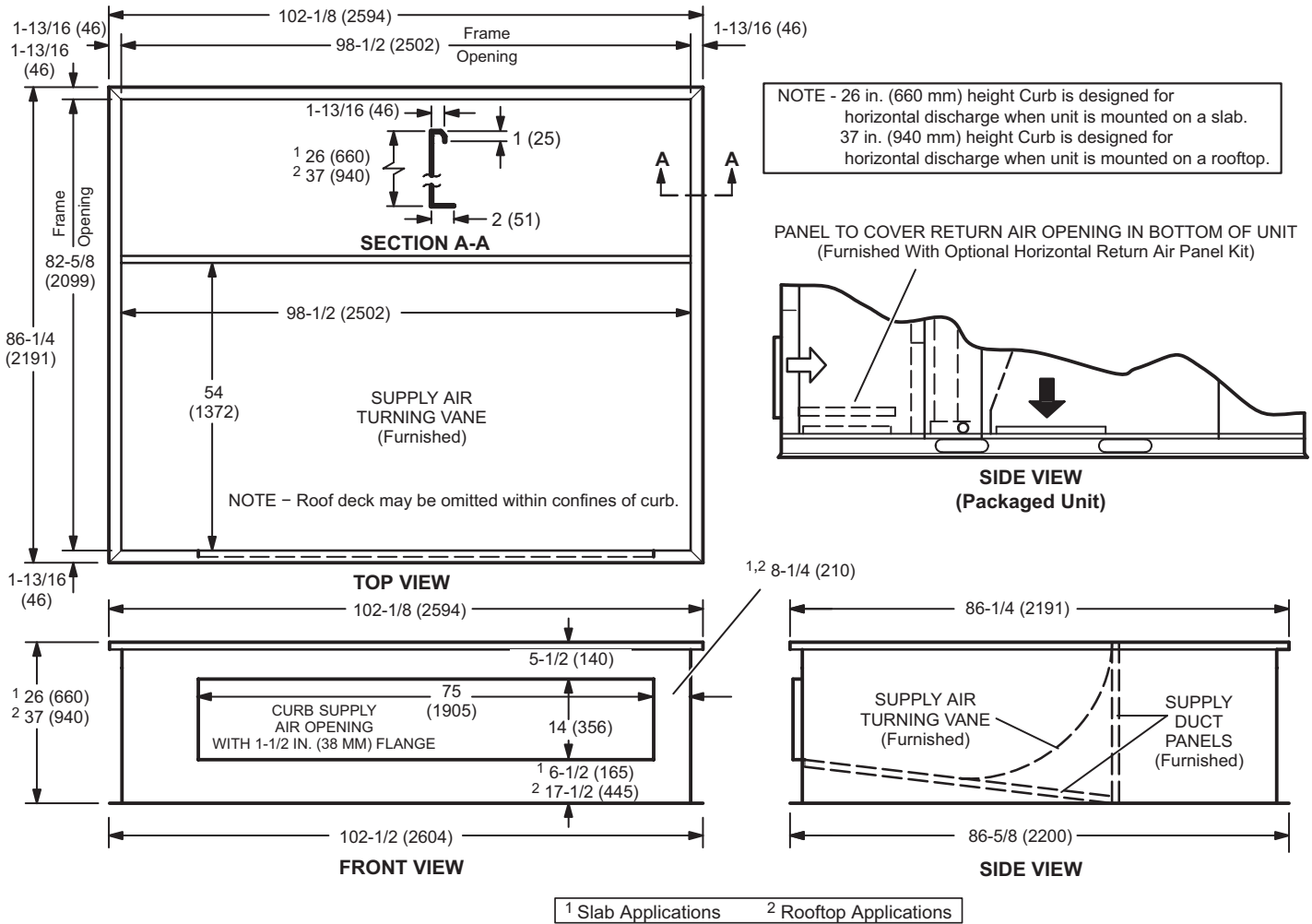

**HORIZONTAL SUPPLY AND RETURN AIR OPENINGS WITH HORIZONTAL ROOF CURB**

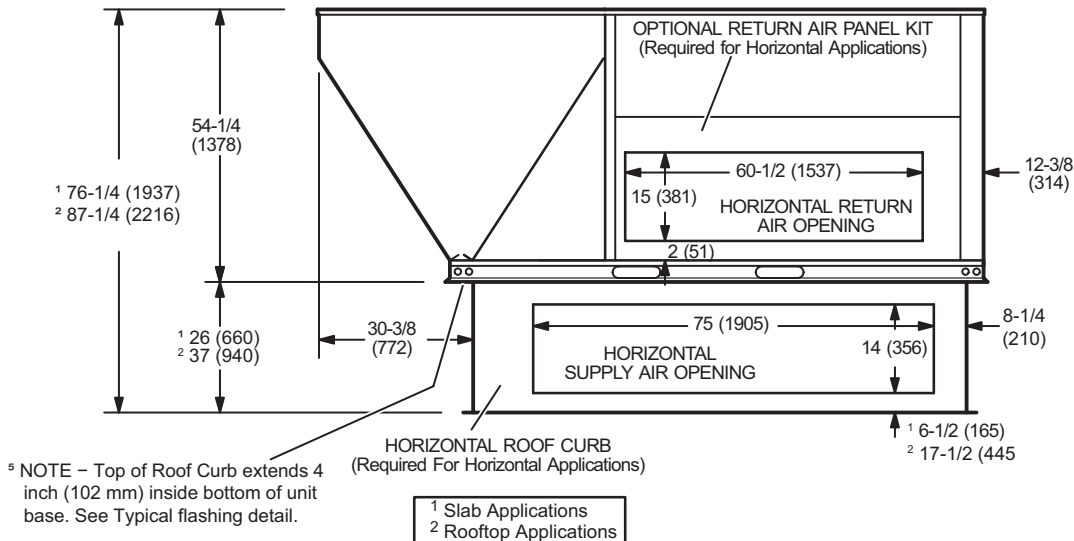

**COMBINATION CEILING SUPPLY AND RETURN DIFFUSERS**

**STEP-DOWN CEILING DIFFUSER**

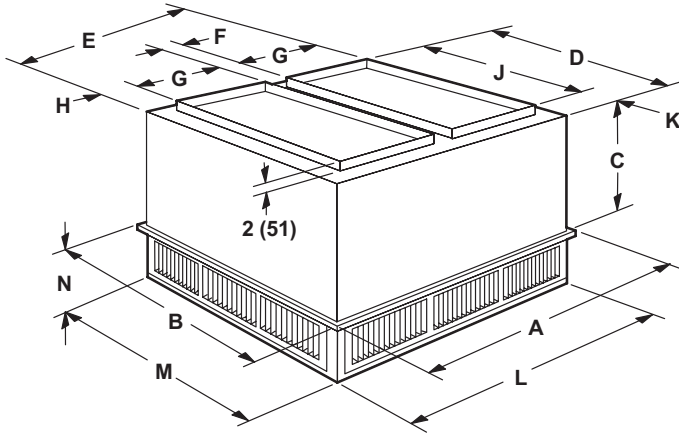

**FLUSH CEILING DIFFUSER**

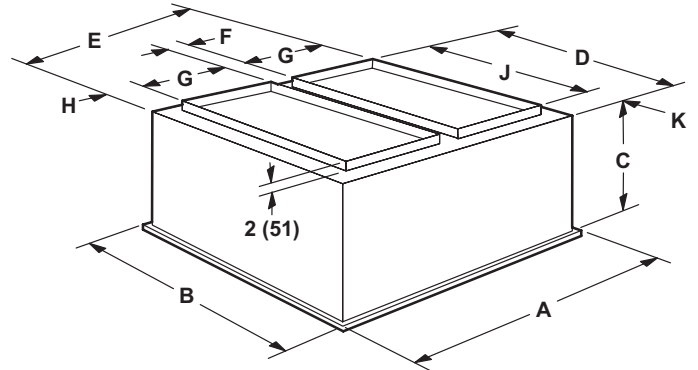

Model Number		RTD11-185S	RTD11-275S
<b>A</b>	in.	47-5/8	59-5/8
	mm	1210	1514
<b>B</b>	in.	47-5/8	59-5/8
	mm	1210	1514
<b>C</b>	in.	24-5/8	30-5/8
	mm	625	778
<b>D</b>	in.	45-1/2	57-1/2
	mm	1156	1461
<b>E</b>	in.	45-1/2	57-1/2
	mm	1156	1461
<b>F</b>	in.	4-1/2	4-1/2
	mm	114	114
<b>G</b>	in.	18	24
	mm	457	610
<b>H</b>	in.	2-1/2	2-1/2
	mm	64	64
<b>J</b>	in.	36	48
	mm	914	1219
<b>K</b>	in.	4-3/4	4-3/4
	mm	121	121
<b>L</b>	in.	45-1/2	57-1/2
	mm	1156	1461
<b>M</b>	in.	45-1/2	57-1/2
	mm	1156	1461
<b>N</b>	in.	10-1/8	11-1/8
	mm	257	283
<b>Duct Size</b>	in.	18 x 36	24 x 48
	mm	457 x 914	610 x 1219

Model Number		FD11-185S	FD11-275S
<b>A</b>	in.	47-5/8	59-5/8
	mm	1210	1514
<b>B</b>	in.	47-5/8	59-5/8
	mm	1210	1514
<b>C</b>	in.	29-1/4	35-1/4
	mm	743	895
<b>D</b>	in.	45	57
	mm	1143	1148
<b>E</b>	in.	45	57
	mm	1143	1448
<b>F</b>	in.	4-1/2	4-1/2
	mm	114	114
<b>G</b>	in.	18	24
	mm	457	610
<b>H</b>	in.	2-1/4	2-1/4
	mm	57	57
<b>J</b>	in.	36	48
	mm	914	1219
<b>K</b>	in.	4-1/2	4-1/2
	mm	114	114
<b>Duct Size</b>	in.	18 x 36	24 x 48
	mm	457 x 914	610 x 1219

## REVISIONS

Sections	Description of Change
Specifications - Gas Heat	Updated minimum air volume cfm for Low Heating.
Weight Data	Updated Roof Curb weights.



**HRAI**  
✓ MEMBER COMPANY



**LENNOX**

Visit us at [www.Lennox.com](http://www.Lennox.com)

For the latest technical information, [www.LennoxCommercial.com](http://www.LennoxCommercial.com)

Contact us at 1-800-4-LENNOX

NOTE - Due to Lennox' ongoing commitment to quality, Specifications, Ratings and Dimensions subject to change without notice and without incurring liability. Improper installation, adjustment, alteration, service or maintenance can cause property damage or personal injury. Installation and service must be performed by a qualified installer and servicing agency.

©2024 Lennox Industries, Inc.