



©2019 Lennox Industries Inc.
Dallas, Texas, USA



RETAIN THESE INSTRUCTIONS FOR FUTURE REFERENCE

These instructions are intended as a general guide and do not supersede local codes in any way. Consult authorities having jurisdiction before installation.

⚠ WARNING

Improper installation, adjustment, alteration, service or maintenance can cause personal injury, loss of life, or damage to property.

Installation and service must be performed by a licensed professional installer (or equivalent) or a service agency.

⚠ IMPORTANT

The Clean Air Act of 1990 bans the intentional venting of refrigerant (CFCs, HCFCs and HFCs) as of July 1, 1992. Approved methods of recovery, recycling or reclaiming must be followed. Fines and/or incarceration may be levied for noncompliance.

⚠ IMPORTANT

This unit must be matched with an indoor coil as specified in *Lennox SSB*H4 Product Specification bulletin*. Coils previously charged with HCFC-22 must be flushed.

NOTICE TO INSTALLER

UNIT PLACEMENT

It is critical for proper unit operation to place outdoor unit on an elevated surface as described in *Unit Placement* section on page 7.

BRAZING LINE SET TO SERVICE VALVES

It is imperative to follow the brazing technique illustrated starting on page 12 to avoid damaging the service valve's internal seals.

INSTALLATION INSTRUCTIONS

Elite® SSB*H4 Units

AIR CONDITIONER UNITS

508039-01

11/2019

TABLE OF CONTENTS

Shipping and Packing List	1
General	1
Unit Dimensions	2
Model Number Identification	2
Unit Parts Arrangement	3
Operating Gauge Set and Service Valves	4
Recovering Refrigerant from Existing System	6
New Unit Placement	7
Removing and Installing Panels	9
New or Replacement Line Set	10
Brazing Connections	12
Flushing Line Set and Indoor Coil	15
Installing Indoor Metering Device	16
Leak Test Line Set and Indoor Coil	17
Evacuating Line Set and Indoor Coil	18
Electrical	19
Servicing Units Delivered Void of Charge	21
Unit Start-Up	21
System Refrigerant	22
System Operation	25
Maintenance	26
Checklists	27

Shipping and Packing List

Check the unit for shipping damage and listed times below are intact. If damaged, or if parts are missing, immediately contact the last shipping carrier.

1 - Assembled outdoor unit.

General

Two-stage Elite® SSB*H4 outdoor units use HFC-410A refrigerant. This unit must be installed with a matching indoor coil and line set as outlined in the Product Specification bulletin (EHB). Elite® SSB*H4 outdoor units are designed for use in expansion valve systems (TXV) only. They are not designed to be used with other refrigerant flow control devices. The Product Specification bulletin lists a TXV kit that must be ordered separately.



Unit Dimensions - Inches (mm)

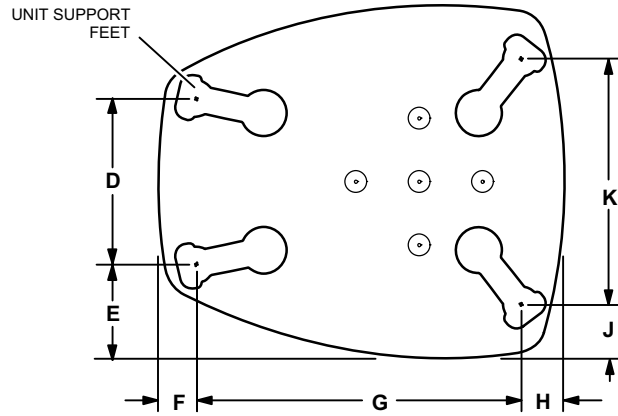

BASE WITH ELONGATED LEGS

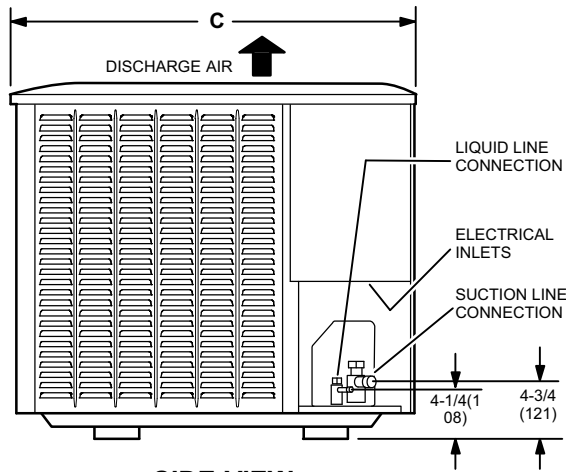

SIDE VIEW

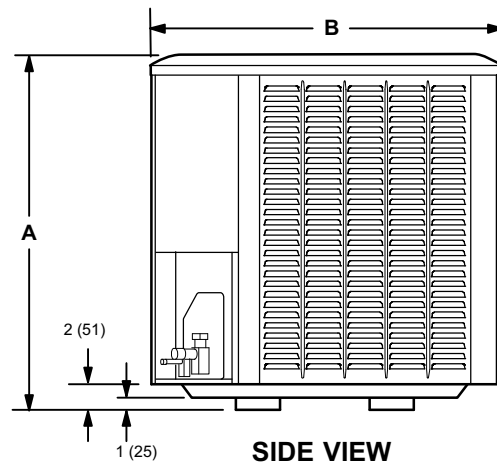

SIDE VIEW

Model Number	A	B	C	D	E	F	G	H	J	K
SSB036H4S4	31 (787)	30-1/2 (775)	35 (889)	13-7/8 (352)	7-3/4 (197)	3-1/4 (83)	27-1/8 (689)	3-5/8 (92)	4-1/2 (114)	20-5/8 (524)
SSB048H4S4	39 (991)	30-1/2 (775)	35 (889)							
SSB060H4S4	45 (1143)	35-1/2 (902)	39-3/8 (1001)	16-7/8 (429)	8-3/4 (222)	3-1/8 (79)	30-3/4 (781)	4-5/8 (117)	3-3/4 (95)	26-7/8 (683)

Model Number Identification

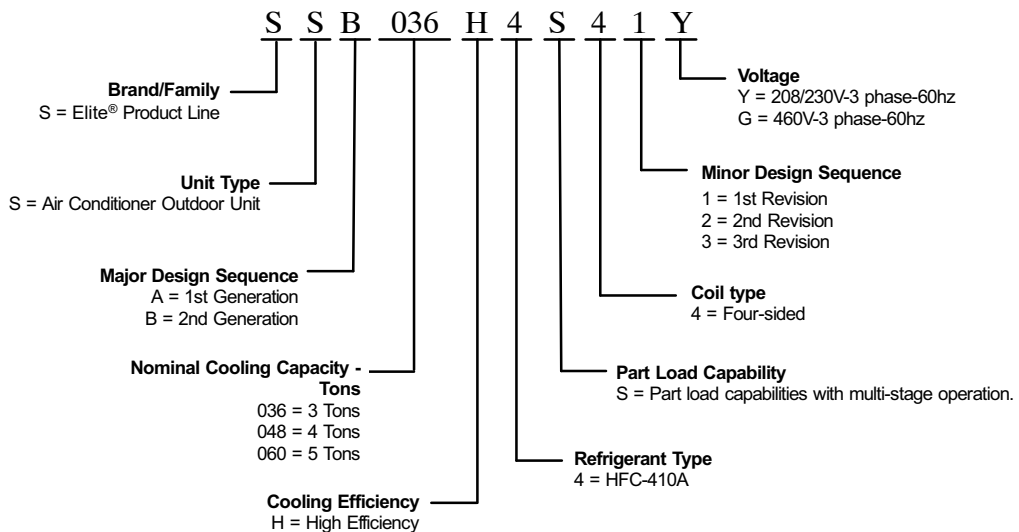

Typical Unit Parts Arrangement

CONTROL PANEL

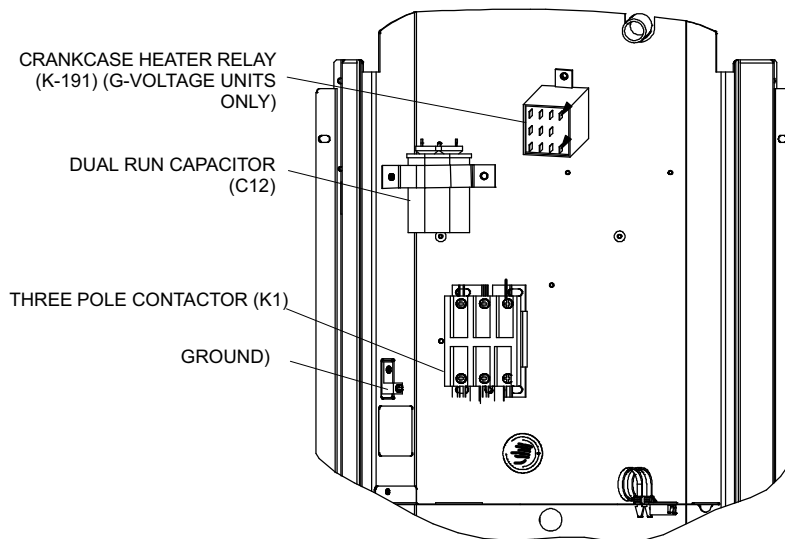

PLUMBING, SWITCHES AND ELECTRICAL COMPONENTS

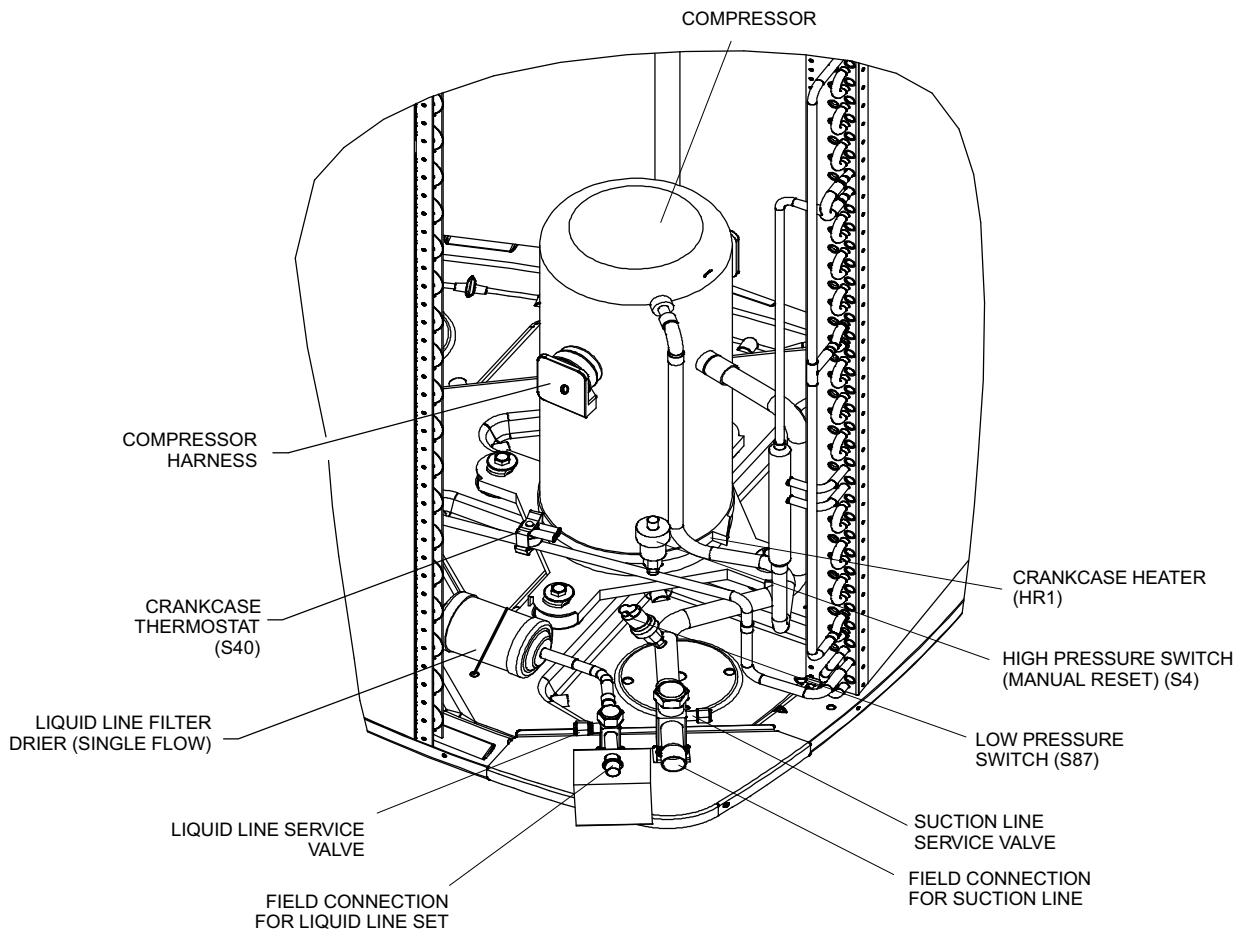

Figure 1. Typical Parts Arrangements

WARNING



Electric Shock Hazard. Can cause injury or death. Unit must be grounded in accordance with national and local codes.

Line voltage is present at all components when unit is not in operation on units with single-pole contactors. Disconnect all remote electric power supplies before opening access panel. Unit may have multiple power supplies.

CAUTION

Physical contact with metal edges and corners while applying excessive force or rapid motion can result in personal injury. Be aware of, and use caution when working near these areas during installation or while servicing this equipment.

Operating Gauge Set and Service Valves

These instructions are intended as a general guide and do not supersede local codes in any way. Consult authorities who have jurisdiction before installation.

TORQUE REQUIREMENTS

When servicing or repairing heating, ventilating, and air conditioning components, ensure the fasteners are appropriately tightened. Table 1 lists torque values for fasteners.

IMPORTANT

Only use Allen wrenches of sufficient hardness (50Rc - Rockwell Harness Scale minimum). Fully insert the wrench into the valve stem recess.

Service valve stems are factory-torqued (from 9 ft-lbs for small valves, to 25 ft-lbs for large valves) to prevent refrigerant loss during shipping and handling. Using an Allen wrench rated at less than 50Rc risks rounding or breaking off the wrench, or stripping the valve stem recess.

See the Lennox Service and Application Notes #C-08-1 for further details and information.

IMPORTANT

To prevent stripping of the various caps used, the appropriately sized wrench should be used and fitted snugly over the cap before tightening.

Table 1. Torque Requirements

Parts	Recommended Torque	
Service valve cap	8 ft.- lb.	11 NM
Sheet metal screws	16 in.- lb.	2 NM
Machine screws #10	28 in.- lb.	3 NM
Compressor bolts	90 in.- lb.	10 NM
Gauge port seal cap	8 ft.- lb.	11 NM

USING MANIFOLD GAUGE SET

When checking the system charge, only use a manifold gauge set that features low loss anti-blow back fittings.

Manifold gauge set used with HFC-410A refrigerant systems must be capable of handling the higher system operating pressures. The gauges should be rated for use with pressures of 0 - 800 psig on the high side and a low side of 30" vacuum to 250 psig with dampened speed to 500 psi. Gauge hoses must be rated for use at up to 800 psig of pressure with a 4000 psig burst rating.

OPERATING SERVICE VALVES

The liquid and vapor line service valves are used for removing refrigerant, flushing, leak testing, evacuating, checking charge and charging.

Each valve is equipped with a service port which has a factory-installed valve stem. Figure 2 provides information on how to access and operating both angle and ball service valves.

Operating Angle-Type Service Valve:

1. Remove stem cap with an appropriately sized wrench.
2. Use a service wrench with a hex-head extension (3/16" for liquid line valve sizes and 5/16" for vapor line valve sizes) to back the stem out counterclockwise as far as it will go.

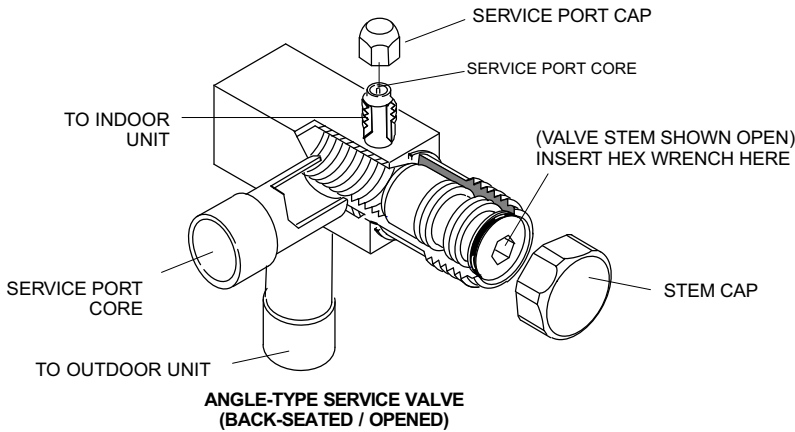

When service valve is **OPEN**, the service port is open to line set, indoor and outdoor unit.

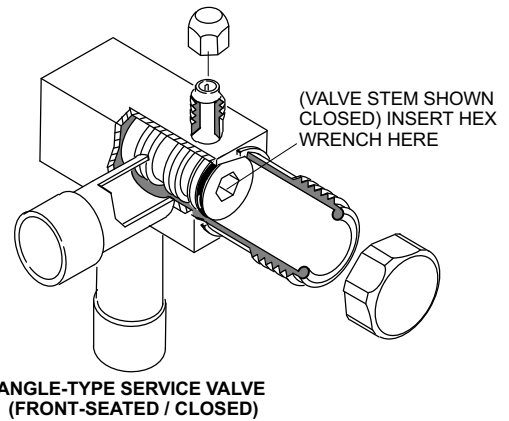

WHEN SERVICE VALVE IS **CLOSED**, THE SERVICE PORT IS OPEN TO THE LINE SET AND INDOOR UNIT.

Operating Ball-Type Service Valve:

1. Remove stem cap with an appropriately sized wrench.
2. To open valve, use a wrench to rotate stem counterclockwise 90°. To close, rotate stem clockwise 90°.

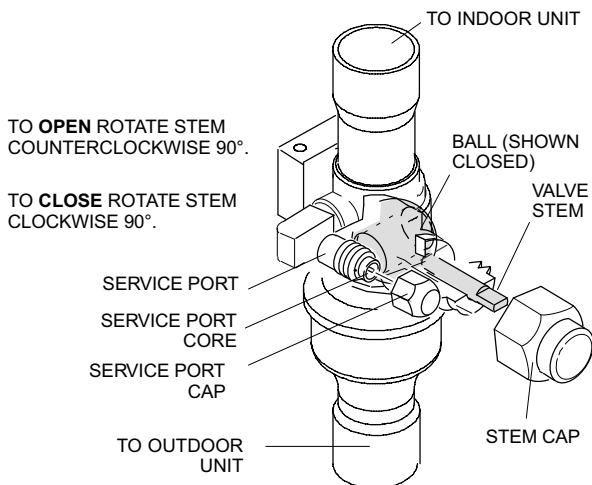

To Access Service Port:

A service port cap protects the service port core from contamination and serves as the primary leak seal.

1. Remove service port cap with an appropriately sized wrench.
2. Connect gauge set to service port.
3. When testing is completed, replace service port cap and tighten as follows:

- With torque wrench: Finger tighten and torque cap per table 1.
- Without torque wrench: Finger tighten and use an appropriately sized wrench to turn an additional 1/6 turn clockwise.

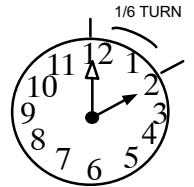

Reinstall Stem Cap:

Stem cap protects the valve stem from damage and serves as the primary seal. Replace the stem cap and tighten as follows:

- With torque wrench: Finger tighten and then torque cap per table 1.
- Without torque wrench: Finger tighten and use an appropriately sized wrench to turn an additional 1/12 turn clockwise.

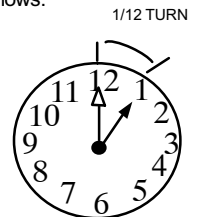

NOTE - A label with specific torque requirements may be affixed to the stem cap. If the label is present, use the specified torque.

Figure 2. Angle and Ball-Type Service Valves

Recovering Refrigerant from Existing System

1 DISCONNECT POWER

Disconnect all power to the existing outdoor unit at the disconnect switch or main fuse box/breaker panel.

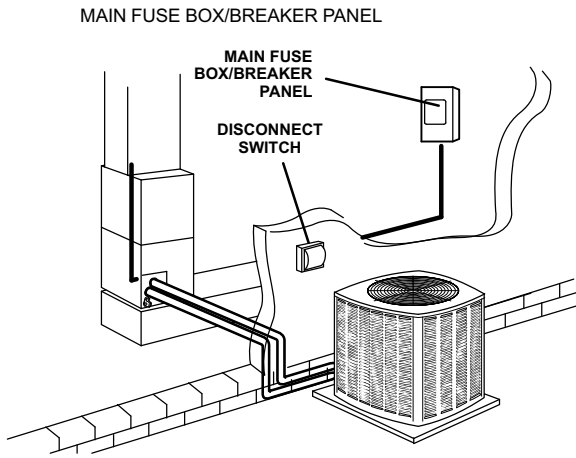

2 CONNECT MANIFOLD GAUGE SET

Connect a gauge set, clean recovery cylinder and a recovery machine to the service ports of the existing unit. Use the instructions provided with the recovery machine to make the connections.

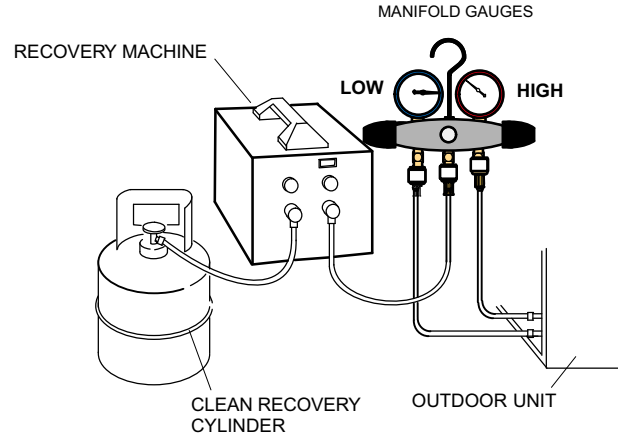

3 RECOVER REFRIGERANT

Remove existing HCFC-22 refrigerant using one of the following procedures:

IMPORTANT - Some system configurations may contain higher than normal refrigerant charge due to either large internal coil volumes, and/or long line sets.

METHOD 1:

Use this method if the existing outdoor unit is not equipped with shut-off valves, or if the unit is not operational and you plan to use the existing HCFC-22 to flush the system.

Remove all HCFC-22 refrigerant from the existing system. Check gauges after shutdown to confirm that the system is completely void of refrigerant.

METHOD 2:

Use this method if the existing outdoor unit is equipped with manual shut-off valves, and you plan to use new HCFC-22 refrigerant to flush the system.

The following devices could prevent full system charge recovery into the outdoor unit:

- Outdoor unit's high or low-pressure switches (if applicable), when tripped, can cycle the compressor **OFF**.
- Compressor can stop pumping due to tripped internal pressure relief valve.
- Compressor has internal vacuum protection that is designed to unload the scrolls (compressor stops pumping) when the pressure ratio meets a certain value or when the suction pressure is as high as 20 psig. (Compressor suction pressures should never be allowed to go into a vacuum. Prolonged operation at low suction pressures will result in overheating of the scrolls and permanent damage to the scroll tips, drive bearings and internal seals.)

Once the compressor cannot pump down to a lower pressure due to one of the above system conditions, shut off the vapor valve. Turn OFF the main power to unit and use a recovery machine to recover any refrigerant left in the indoor coil and line set.

Perform the following task:

- A Start the existing HCFC-22 system in the cooling mode and close the liquid line valve.
- B Use the compressor to pump as much of the existing HCFC-22 refrigerant into the outdoor unit until the outdoor system is full. Turn the outdoor unit main power OFF and use a recovery machine to remove the remaining refrigerant from the system.

Note - It may be necessary to bypass the low pressure switches (if equipped) to ensure complete refrigerant evacuation.

- C When the low side system pressures reach 0 psig, close the vapor line valve.
- D Check gauges after shutdown to confirm that the valves are not allowing refrigerant to flow back into the low side of the system.

Figure 3. Recovering Refrigerant

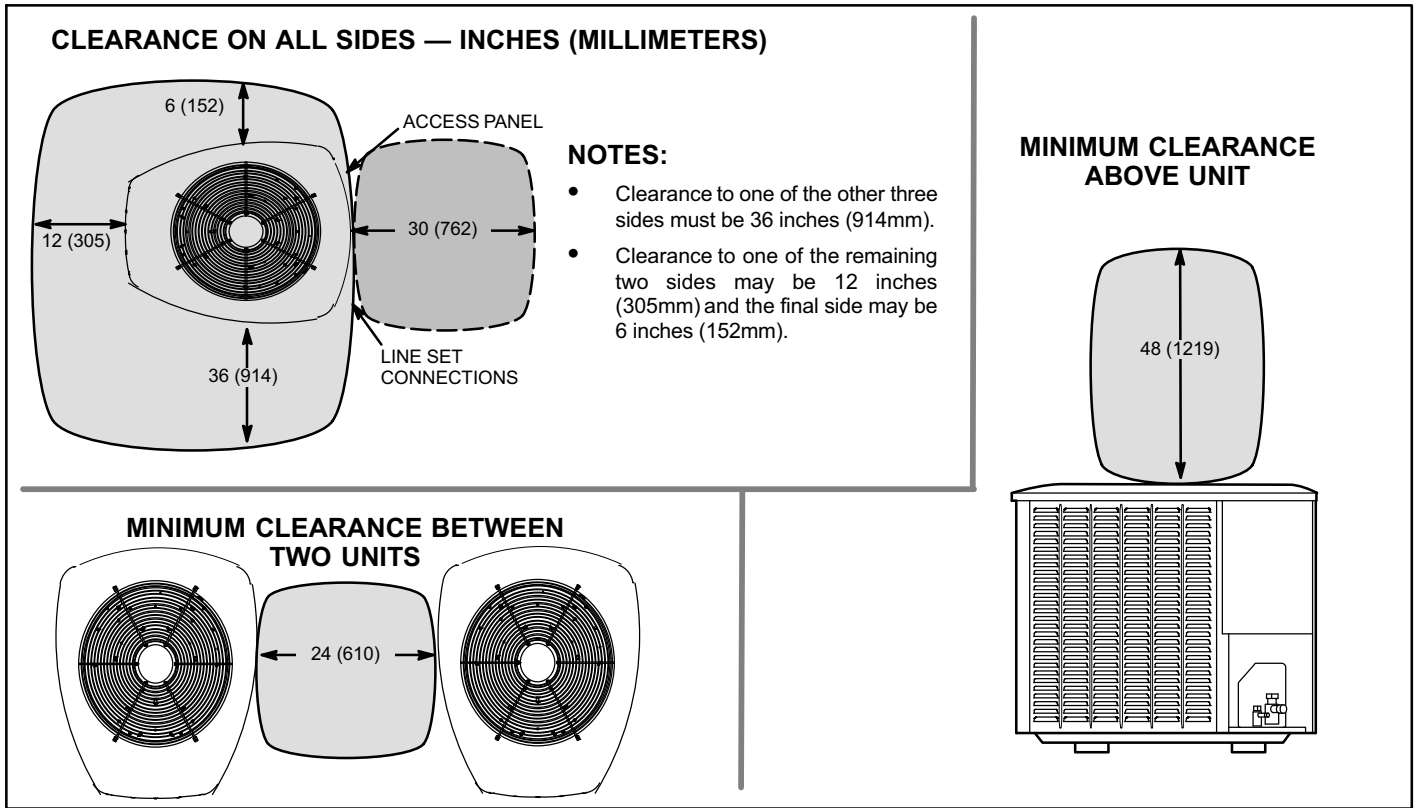

Figure 4. Installation Clearances

New Unit Placement

CAUTION
 In order to avoid injury, take proper precaution when lifting heavy objects.

See *Unit Dimensions* on page 3 for sizing mounting slab, platforms or supports. Refer to figure 4 for mandatory installation clearance requirements.

POSITIONING CONSIDERATIONS

Consider the following when positioning the unit:

- Some localities are adopting sound ordinances based on the unit's sound level registered from the adjacent property, not from the installation property. Install the unit as far as possible from the property line.
- When possible, do not install the unit directly outside a window. Glass has a very high level of sound transmission. For proper placement of unit in relation to a window see the provided illustration in figure 5, detail A.

PLACING UNIT ON SLAB

When installing unit at grade level, the top of the slab should be high enough above grade so that water from higher ground will not collect around the unit. The slab should have a slope tolerance as described in figure 5, detail B.

NOTE - If necessary for stability, anchor unit to slab as illustrated in figure 5, detail D.

IMPORTANT
 To help stabilize an outdoor unit, some installations may require strapping the unit to the pad using brackets and anchors commonly available in the marketplace.

ELEVATING THE UNIT

Units are outfitted with elongated support feet as illustrated in figure 5, detail C.

If additional elevation is necessary, raise the unit by extending the height of the unit support feet. This may be achieved by using a 2 inch (50.8mm) Schedule 40 female threaded adapter.

The specified coupling will fit snugly into the recessed portion of the feet. Use additional 2 inch (50.8mm) Schedule 40 male threaded adaptors which can be threaded into the female threaded adaptors to make additional adjustments to the level of the unit.

NOTE - Keep the height of extenders short enough to ensure a sturdy installation. If it is necessary to extend further, consider a different type of field-fabricated framework that is sturdy enough for greater heights.

DETAIL A— Outside Unit Placement

Install unit away from windows.

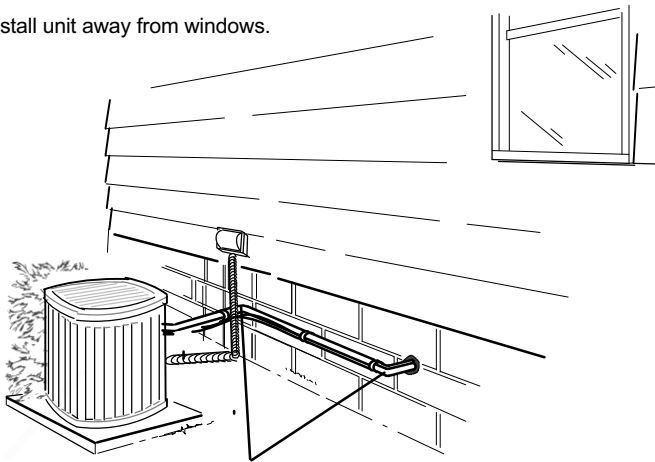

TWO 90° ELBOWS INSTALLED IN LINE SET WILL REDUCE LINE SET VIBRATION.

DETAIL B— Slab Mounting at Ground Level

Install unit level or, if on a slope, maintain slope tolerance of two (2) degrees (or two inches per five feet [50 mm per 1.5 m]) away from building structure.

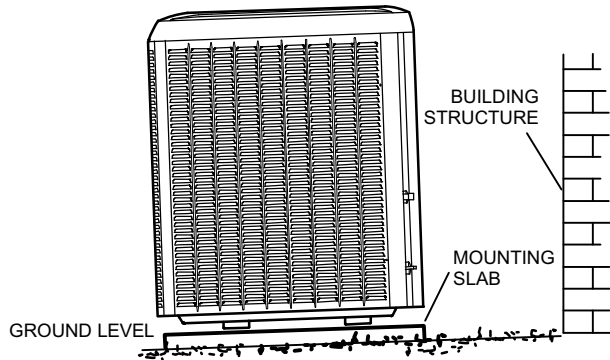

DETAIL C— Elevated Slab Mounting using Feet Extenders

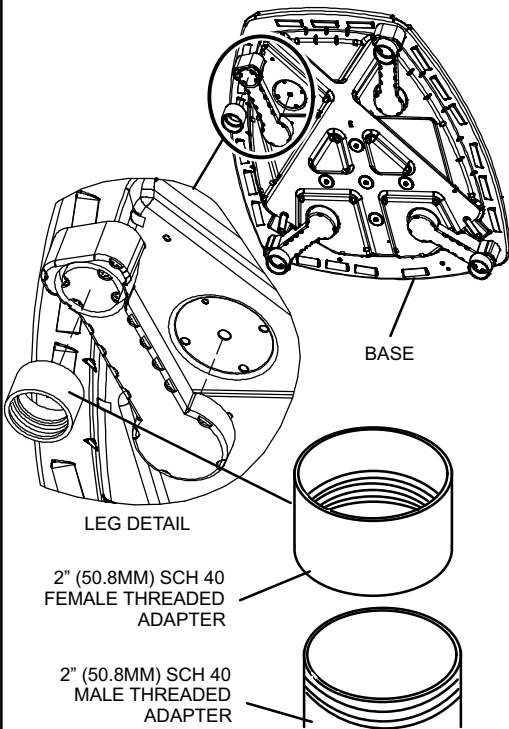

Use additional 2" SCH 40 male threaded adapters which can be threaded into the female threaded adapters to make additional adjustments to the level of the unit.

STABILIZING UNIT ON UNEVEN SURFACES

DETAIL D— Slab Side Mounting

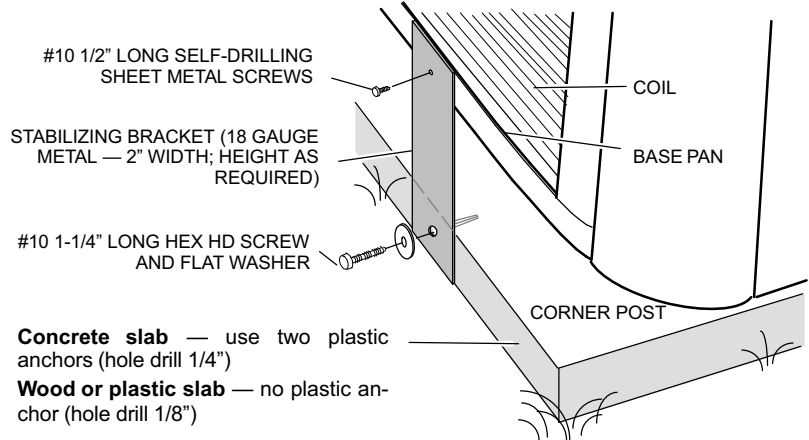

Concrete slab — use two plastic anchors (hole drill 1/4")

Wood or plastic slab — no plastic anchor (hole drill 1/8")

DETAIL E— Deck Top Mounting

Stabilizing bracket (18 gauge metal — 2" (50.8mm) width; height as required); bend to form right angle as exemplified below.

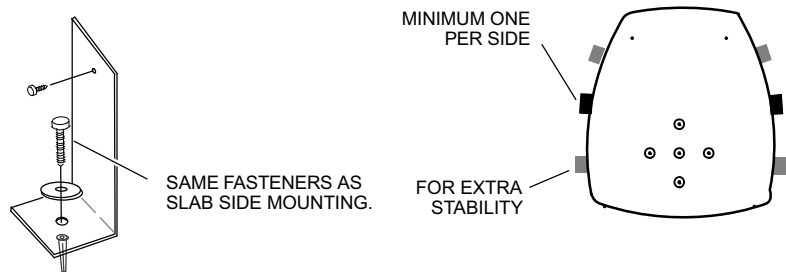

One bracket per side (minimum). For extra stability, two brackets per side, two inches (51mm) from each corner.

IMPORTANT - To help stabilize an outdoor unit, some installations may require strapping the unit to the pad using brackets and anchors commonly available in the marketplace.

Figure 5. Placement, Slab Mounting and Stabilizing Unit

ROOF MOUNTING

Install the unit a minimum of 6 inches (152 mm) above the roof surface to avoid ice build-up around the unit. Locate the unit above a load bearing wall or area of the roof that can adequately support the unit. Consult local codes for rooftop applications.

NOTICE

Roof Damage!

This system contains both refrigerant and oil. Some rubber roofing material may absorb oil and cause the rubber to swell when it comes into contact with oil. The rubber will then bubble and could cause leaks. Protect the roof surface to avoid exposure to refrigerant and oil during service and installation. Failure to follow this notice could result in damage to roof surface.

Removing and Installing Panels

⚠ IMPORTANT

Do not allow panels to hang on unit by top tab. Tab is for alignment and not designed to support weight of panel.

⚠ WARNING

To prevent personal injury, or damage to panels, unit or structure, be sure to observe the following:

While installing or servicing this unit, carefully stow all removed panels out of the way, so that the panels will not cause injury to personnel, nor cause damage to objects or structures nearby, nor will the panels be subjected to damage (e.g., being bent or scratched).

While handling or stowing the panels, consider any weather conditions, especially windy conditions, that may cause panels to be blown around and battered.

LOUVERED PANEL REMOVAL

Remove the louvered panels as follows:

1. Remove two screws, allowing the panel to swing open slightly.
2. Hold the panel firmly throughout this procedure. Rotate bottom corner of panel away from hinged corner post until lower three tabs clear the slots as illustrated in **detail B**.
3. Move panel down until lip of upper tab clears the top slot in corner post as illustrated in **detail A**.

LOUVERED PANEL INSTALLATION

Position the panel almost parallel with the unit as illustrated in **detail D** with the screw side as close to the unit as possible. Then, in a continuous motion:

1. Slightly rotate and guide the lip of top tab inward as illustrated in **detail A** and **C**; then upward into the top slot of the hinge corner post.
2. Rotate panel to vertical to fully engage all tabs.
3. Holding the panel's hinged side firmly in place, close the right-hand side of the panel, aligning the screw holes.
4. When panel is correctly positioned and aligned, insert the screws and tighten.

Detail C

MAINTAIN MINIMUM PANEL ANGLE (AS CLOSE TO PARALLEL WITH THE UNIT AS POSSIBLE) WHILE INSTALLING PANEL.

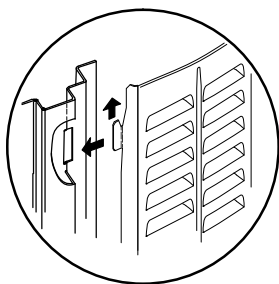

ANGLE MAY BE TOO EXTREME

HOLD DOOR FIRMLY TO THE HINGED SIDE TO MAINTAIN FULLY-ENGAGED TABS

PREFERRED ANGLE FOR INSTALLATION

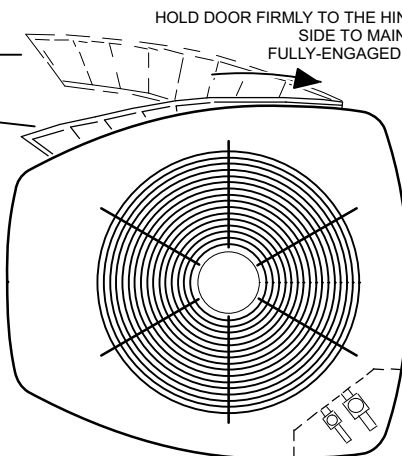

IMPORTANT! DO NOT ALLOW PANELS TO HANG ON UNIT BY TOP TAB. TAB IS FOR ALIGNMENT AND NOT DESIGNED TO SUPPORT WEIGHT OF PANEL.

PANEL SHOWN SLIGHTLY ROTATED TO ALLOW TOP TAB TO EXIT (OR ENTER) TOP SLOT FOR REMOVING (OR INSTALLING) PANEL.

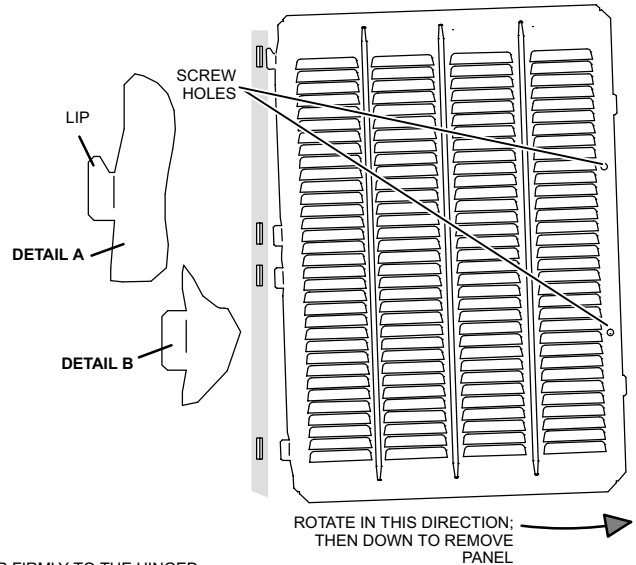

Figure 6. Removing and Installing Panels

New or Replacement Line Set

REFRIGERANT LINE SET

This section provides information on installation or replacement of existing line set. If new or replacement line set is not being installed then proceed to *Brazing Connections* on page 12.

⚠ IMPORTANT

Lennox highly recommends changing line set when converting the existing system from HCFC-22 to HFC-410A. If that is not possible and the line set is the proper size as reference in table 2, use the procedure outlined under *Flushing the System* on page 13.

If refrigerant lines are routed through a wall, then seal and isolate the opening so vibration is not transmitted to the building. Pay close attention to line set isolation during installation of any HVAC system. When properly isolated from building structures (walls, ceilings, floors), the refrigerant lines will not create unnecessary vibration and subsequent sounds. See figure 7 for recommended installation practices. Also, consider the following when placing and installing a high-efficiency outdoor unit.

Liquid lines that meter the refrigerant, such as RFC1 liquid lines, must not be used in this application. Existing line set of proper size as listed in table 2 may be reused. If system was previously charged with HCFC-22 refrigerant, then existing line set must be flushed (see *Flushing Line Set and Indoor Coil* on page 15).

Field refrigerant piping consists of liquid and vapor lines from the outdoor unit to the indoor unit coil (brazed connections). Use Lennox L15 (sweat, non-flare) series line set or field-fabricated refrigerant line sizes as listed in table 2.

NOTE - When installing refrigerant lines longer than 50 feet, see the Lennox Refrigerant Piping Design and Fabrication Guidelines, CORP. 9351-L9, or contact Lennox Technical Support Product Applications for assistance.

To obtain the correct information from Lennox, be sure to communicate the following information:

- Model SSB*H4 and size of unit (e.g. -036).
- Line set diameters for the unit being installed as listed in table 2 and total length of piping.
- Number of elbows vertical rise or drop in the piping.

The compressor is charged with sufficient Polyol ester oil for line set lengths up to 50 feet. Recommend adding oil to system based on the amount of refrigerant charge in the system. No need to add oil in system with 20 pounds of refrigerant or less. For systems over 20 pounds - add one ounce of oil for every five pounds of refrigerant.

Recommended topping-off POE oils are Mobil EAL ARCTIC 22 CC or ICI EMKARATE™ RL32CF.

⚠ WARNING

Polyol Ester (POE) oils used with HFC-410A refrigerant absorb moisture very quickly. It is very important that the refrigerant system be kept closed as much as possible. **DO NOT** remove line set caps or service valve stub caps until you are ready to make connections.

⚠ IMPORTANT

Mineral oils are not compatible with HFC-410A. If oil must be added, it must be a Polyol Ester oil.

Table 2. Refrigerant Line Set — Inches (mm)

Model Number	Field Connections		Recommended Line Set		
	Liquid Line	Vapor Line	Liquid Line	Vapor Line	L15 Line Sets
SSB036H4S4	3/8 in. (10 mm)	7/8 in. (22 mm)	3/8 in. (10 mm)	7/8 in (22 mm)	L15-65 — 15 ft. - 50 ft. (4.6 m - 15 m)
SSB048H4S4		1-1/8 in. (29 mm)	3/8 in. (10 mm)	1-1/8 in. (29 mm)	
SSB060H4S4	3/8 in. (10 mm)	1-1/8 in. (29 mm)	3/8 in. (10 mm)	1-1/8 in. (29 mm)	Field Fabricated

NOTE - Some applications may require a field provided 7/8" to 1-1/8" adapter

Line Set Isolation — The following illustrations are examples of proper refrigerant line set isolation:

REFRIGERANT LINE SET — TRANSITION FROM VERTICAL TO HORIZONTAL

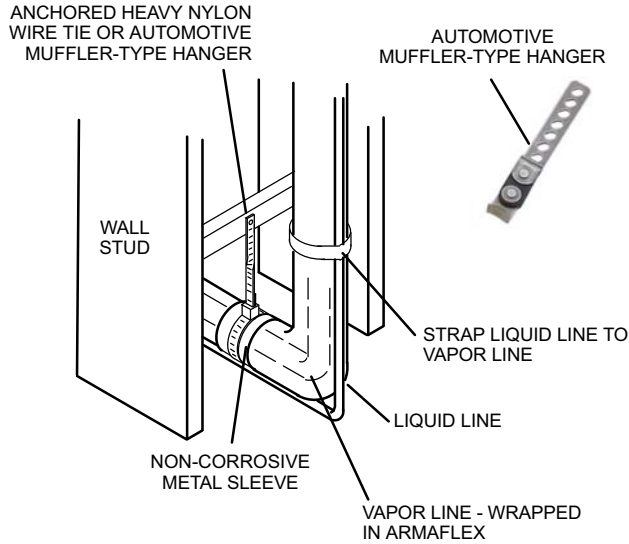

REFRIGERANT LINE SET — INSTALLING VERTICAL RUNS (NEW CONSTRUCTION SHOWN)

NOTE - Insulate liquid line when it is routed through areas where the surrounding ambient temperature could become higher than the temperature of the liquid line or when pressure drop is equal to or greater than 20 psig.

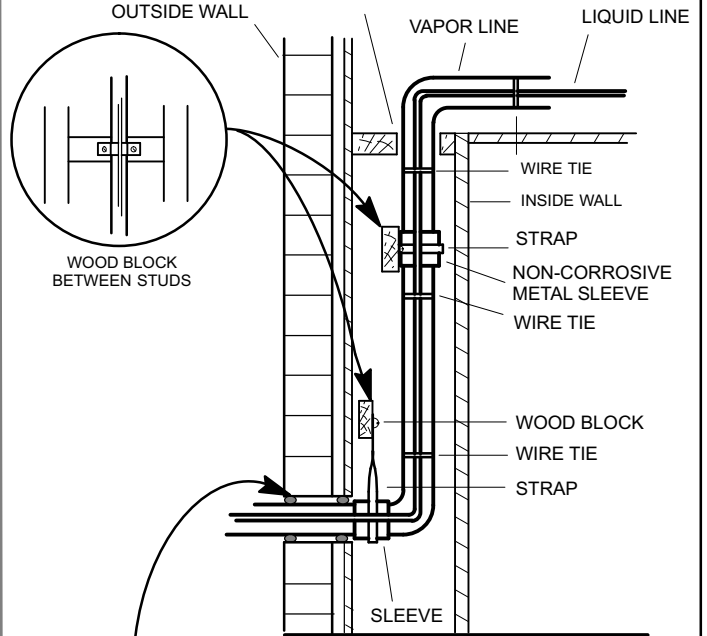

REFRIGERANT LINE SET — INSTALLING HORIZONTAL RUNS

To hang line set from joist or rafter, use either metal strapping material or anchored heavy nylon wire ties.

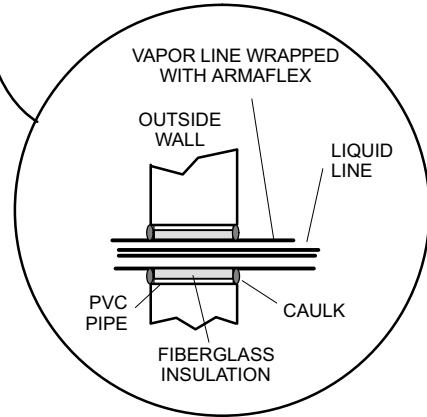
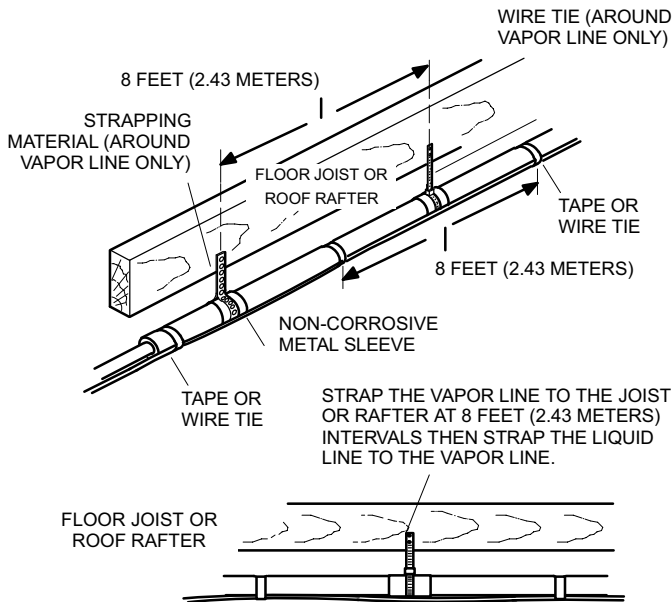

NOTE - Similar installation practices should be used if line set is to be installed on exterior of outside wall.

Figure 7. Line Set Installation

Brazing Connections

Use the procedures outline in figures 8 and 9 for brazing line set connections to service valves.

WARNING



Danger of fire. Bleeding the refrigerant charge from only the high side may result in pressurization of the low side shell and suction tubing. Application of a brazing torch to a pressurized system may result in ignition of the refrigerant and oil mixture - Check the high and low pressures before applying heat.

WARNING



When using a high pressure gas such as dry nitrogen to pressurize a refrigeration or air conditioning system, use a regulator that can control the pressure down to 1 or 2 psig (6.9 to 13.8 kPa).

CAUTION

Brazing alloys and flux contain materials which are hazardous to your health.

Avoid breathing vapors or fumes from brazing operations. Perform operations only in well-ventilated areas.

Wear gloves and protective goggles or face shield to protect against burns.

Wash hands with soap and water after handling brazing alloys and flux.

IMPORTANT

Connect gauge set low pressure side to vapor line service valve and repeat procedure starting at paragraph 4 for brazing the liquid line to service port valve.

IMPORTANT

Allow braze joint to cool before removing the wet rag from the service valve. Temperatures above 250°F can damage valve seals.

IMPORTANT

Use silver alloy brazing rods with 5% minimum silver alloy for copper-to-copper brazing. Use 45% minimum alloy for copper-to-brass and copper-to-steel brazing.

WARNING



Fire, Explosion and Personal Safety Hazard.

Failure to follow this warning could result in damage, personal injury or death.

Never use oxygen to pressurize or purge refrigeration lines. Oxygen, when exposed to a spark or open flame, can cause fire and/or an explosion, that could result in property damage, personal injury or death.

1 CUT AND DEBUR

Cut ends of the refrigerant lines square (free from nicks or dents) and debur the ends. The pipe must remain round. Do not crimp end of the line.

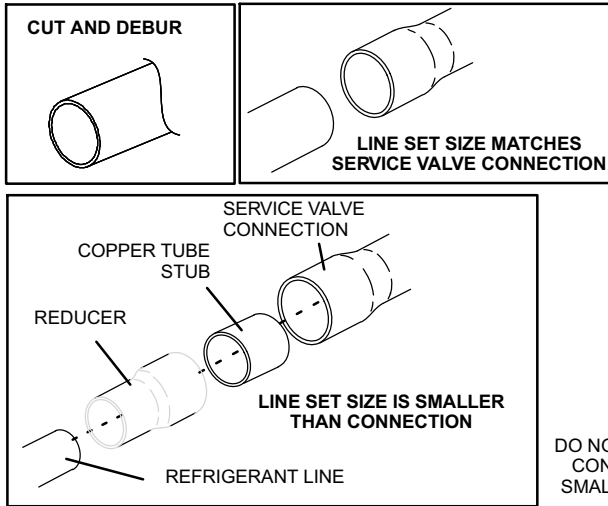

2 CAP AND CORE REMOVAL

Remove service cap and core from both the vapor and liquid line service ports.

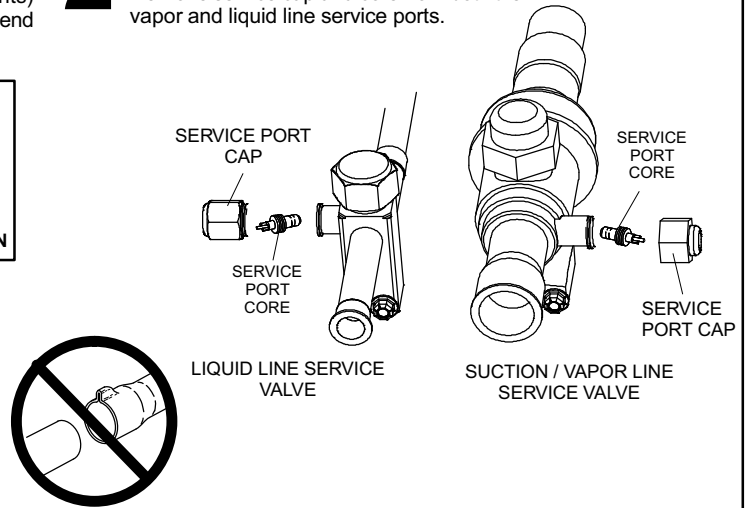

DO NOT CRIMP SERVICE VALVE CONNECTOR WHEN PIPE IS SMALLER THAN CONNECTION

3 ATTACH THE MANIFOLD GAUGE SET FOR BRAZING LIQUID AND SUCTION / VAPOR LINE SERVICE VALVES

Flow regulated nitrogen (at 1 to 2 psig) through the low-side refrigeration gauge set into the liquid line service port valve, and out of the suction / vapor line service port valve.

- A Connect gauge set low pressure side to liquid line service valve (service port).
- B Connect gauge set center port to bottle of nitrogen with regulator.
- C Remove Schrader valve in suction / vapor line service port to allow nitrogen to escape.

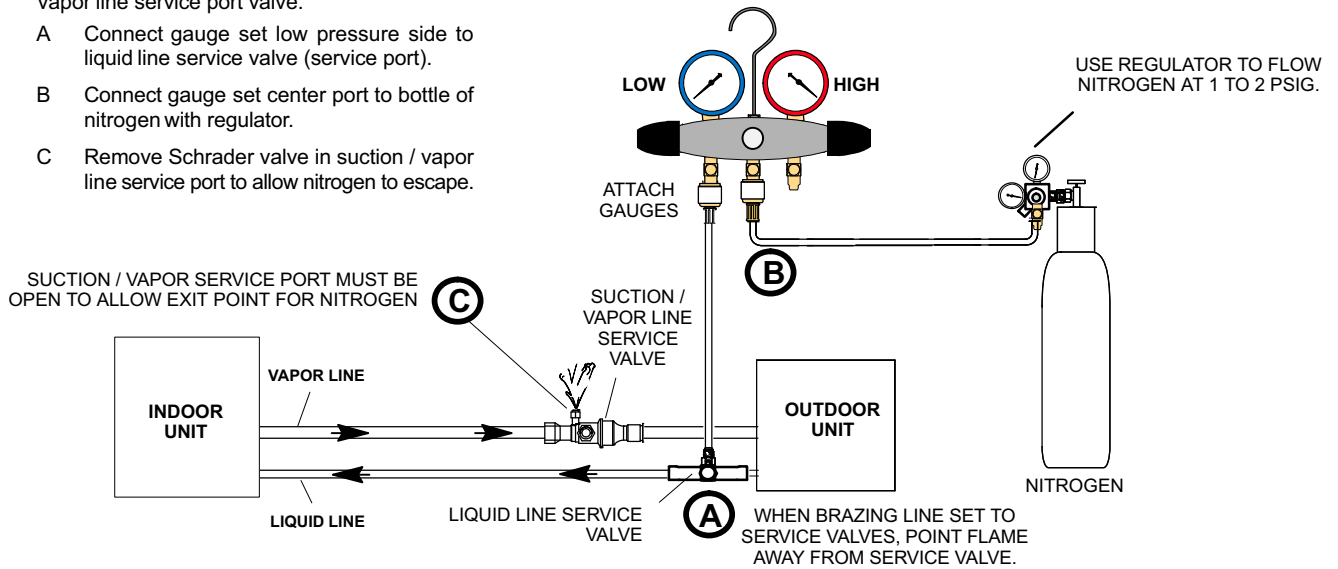

Figure 8. Brazing Procedures

4 WRAP SERVICE VALVES

To help protect service valve seals during brazing, wrap a saturated cloth around service valve bodies and copper tube stub. Use another saturated cloth underneath the valve body to protect the base paint.

5 FLOW NITROGEN

Flow regulated nitrogen (at 1 to 2 psig) through the refrigeration gauge set into the valve stem port connection on the liquid service valve and out of the suction / vapor valve stem port. See steps 3A, 3B and 3C on manifold gauge set connections

6 BRAZE LINE SET

Wrap both service valves with a saturated cloth as illustrated here before brazing to line set.

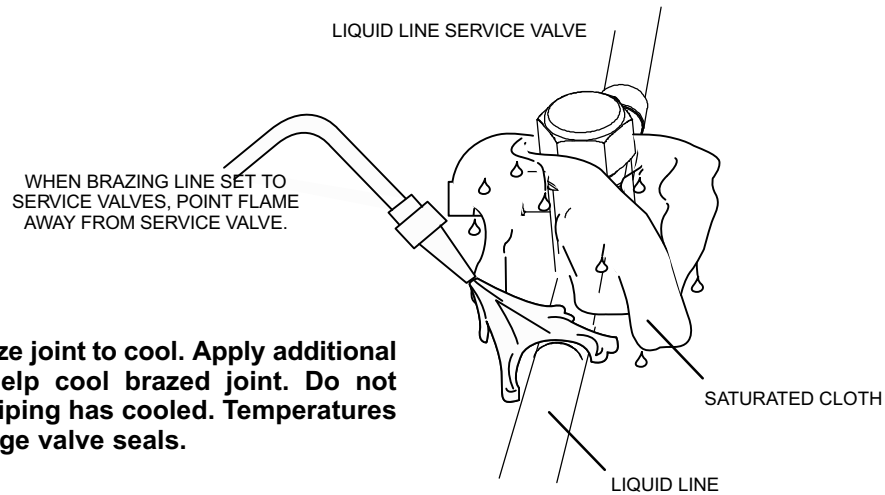

IMPORTANT - Allow braze joint to cool. Apply additional saturated cloths to help cool brazed joint. Do not remove wet rag until piping has cooled. Temperatures above 250°F will damage valve seals.

WARNING

1. **FIRE, PERSONAL INJURY, OR PROPERTY DAMAGE** will result if you do not wrap a wet cloth around both liquid and suction line service valve bodies and copper tube stub while brazing in the line set! The braze, when complete, must be quenched with water to absorb any residual heat.
2. Do not open service valves until refrigerant lines and indoor coil have been leak-tested and evacuated. Refer to procedures provided in this supplement.

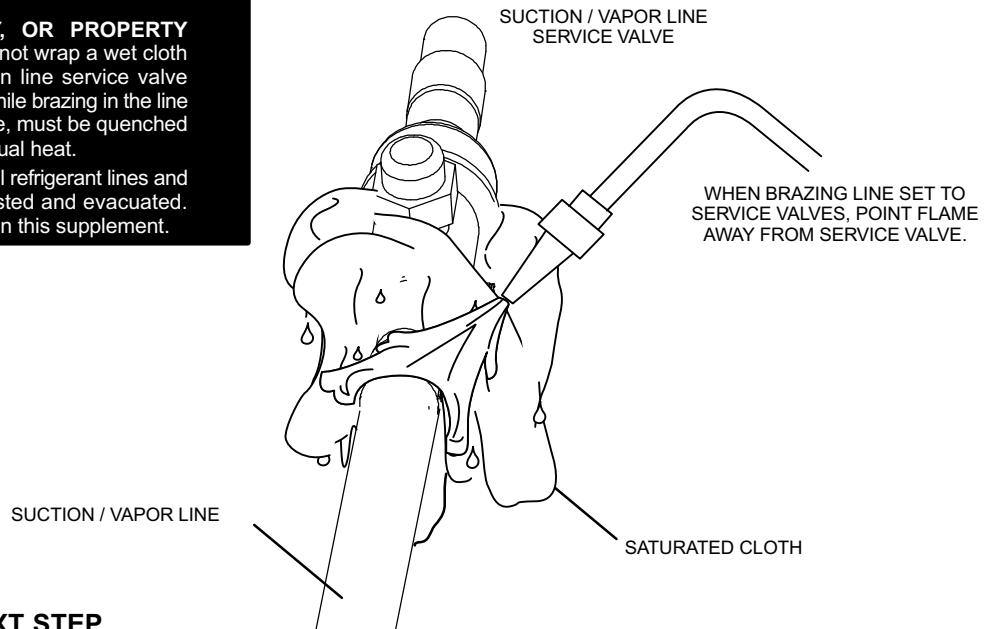

7 PREPARATION FOR NEXT STEP

After all connections have been brazed, disconnect manifold gauge set from service ports. Apply saturated rags to both services valves to cool piping. Once piping is cool, remove all wet cloths. Refer to the unit installation instructions for the next step in preparing the unit.

Figure 9. Brazing Procedures (continued)

Flushing Line Set and Indoor Coil

1A TYPICAL EXISTING FIXED ORIFICE REMOVAL PROCEDURE (UNCASED OR COIL SHOWN)

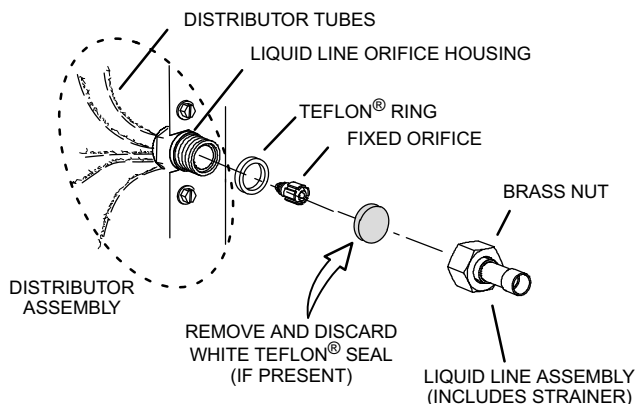

- A On fully cased coils, remove the coil access and plumbing panels.
- B Remove any shipping clamps holding the liquid line and distributor assembly.
- C Using two wrenches, disconnect liquid line from liquid line orifice housing. Take care not to twist or damage distributor tubes during this process.
- D Remove and discard fixed orifice, valve stem assembly if present and Teflon® washer as illustrated above.
- E Use a field-provided fitting to temporary reconnect the liquid line to the indoor unit's liquid line orifice housing.

1B TYPICAL EXISTING EXPANSION VALVE REMOVAL PROCEDURE (UNCASED COIL SHOWN)

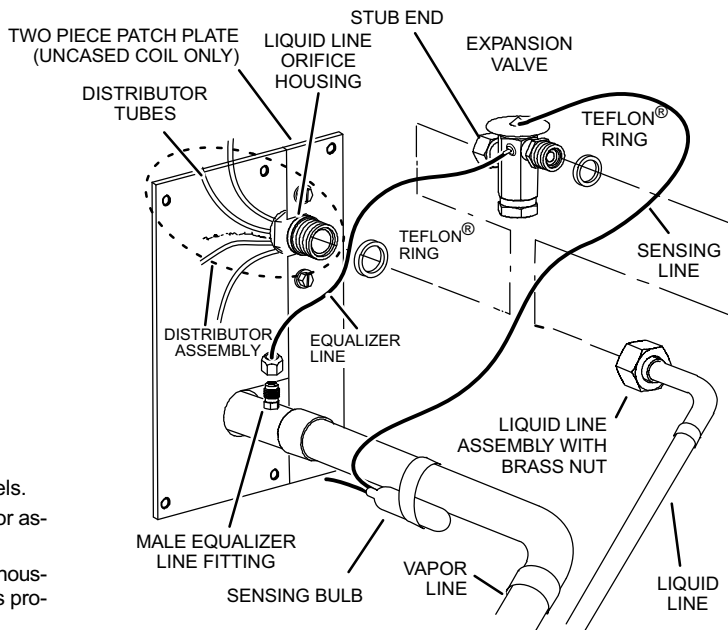

- A On fully cased coils, remove the coil access and plumbing panels.
- B Remove any shipping clamps holding the liquid line and distributor assembly.
- C Disconnect the equalizer line from the expansion valve equalizer line fitting on the vapor line.
- D Remove the vapor line sensing bulb.
- E Disconnect the liquid line from the expansion valve at the liquid line assembly.
- F Disconnect the expansion valve from the liquid line orifice housing. Take care not to twist or damage distributor tubes during this process.
- G Remove and discard expansion valve and the two Teflon® rings.
- H Use a field-provided fitting to temporary reconnect the liquid line to the indoor unit's liquid line orifice housing.

2 CONNECT GAUGES AND EQUIPMENT FOR FLUSHING PROCEDURE

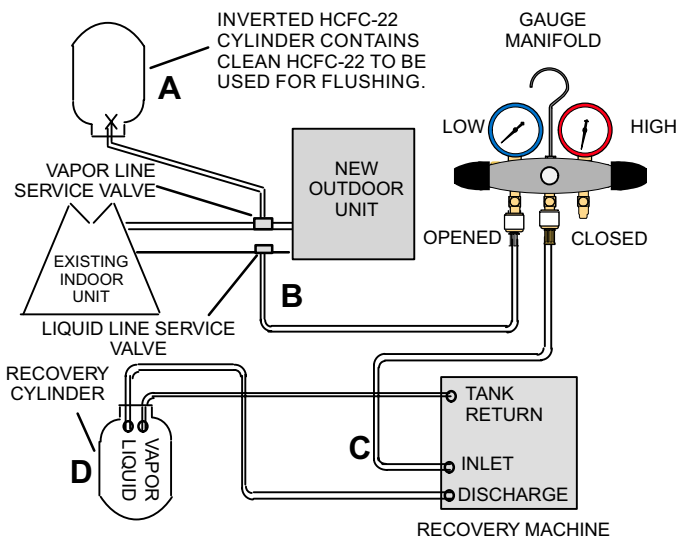

- A Inverted HCFC-22 cylinder with clean refrigerant to the vapor service valve.
- B HCFC-22 gauge set (low side) to the liquid line valve.
- C HCFC-22 gauge set center port to inlet on the recovery machine with an empty recovery tank to the gauge set.
- D Connect recovery tank to recovery machines per machine instructions.

3 FLUSHING LINE SET

The line set and indoor unit coil must be flushed with at least the same amount of clean refrigerant that previously charged the system. Check the charge in the flushing cylinder before proceeding.

- A Set the recovery machine for liquid recovery and start the recovery machine. Open the gauge set valves to allow the recovery machine to pull a vacuum on the existing system line set and indoor unit coil.
- B Invert the cylinder of clean HCFC-22 and open its valve to allow liquid refrigerant to flow into the system through the vapor line valve. Allow the refrigerant to pass from the cylinder and through the line set and the indoor unit coil before it enters the recovery machine.
- C After all of the liquid refrigerant has been recovered, switch the recovery machine to vapor recovery so that all of the HCFC-22 vapor is recovered. Allow the recovery machine to pull down to 0 on the system.
- D Close the valve on the inverted HCFC-22 drum and the gauge set valves. Pump the remaining refrigerant out of the recovery machine and turn the machine off.

Figure 10. Installing Indoor Expansion Valve

Installing Indoor Metering Device

This outdoor unit is designed for use in systems that use a expansion valve metering device at the indoor coil. See the *Lennox SSB*H4 Product Specification bulletin* for approved expansion valve kit match-ups. The expansion valve unit can be installed either internal or external to the

indoor coil. In applications where an uncased coil is being installed in a field-provided plenum, install the expansion valve in a manner that will provide access for field servicing of the expansion valve. Refer to below illustration for reference during installation of expansion valve unit.

INDOOR EXPANSION VALVE INSTALLATION

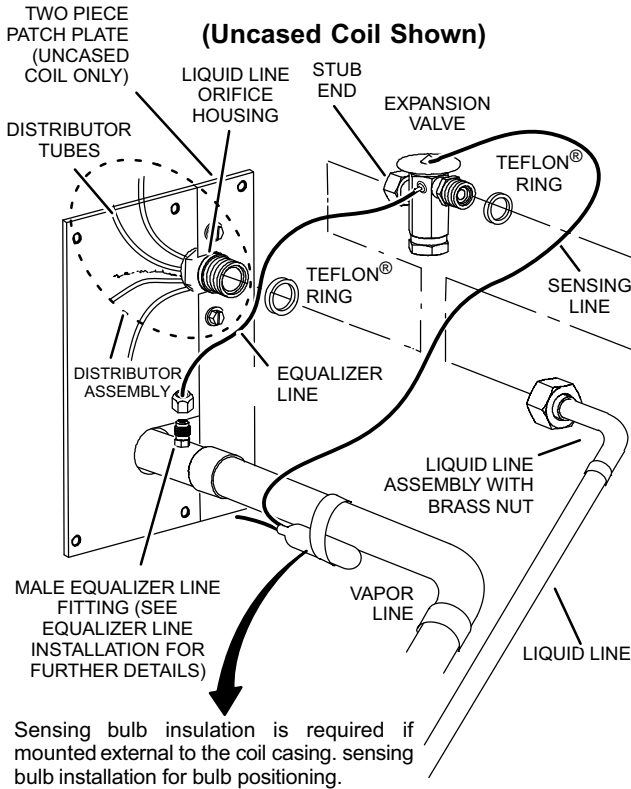

Sensing bulb insulation is required if mounted external to the coil casing, sensing bulb installation for bulb positioning.

- Install one of the provided Teflon® rings around the stubbed end of the expansion valve and lightly lubricate the connector threads and expose surface of the Teflon® ring with refrigerant oil.
- Attach the stubbed end of the expansion valve to the liquid line orifice housing. Finger tighten and use an appropriately sized wrench to turn an additional 1/2 turn clockwise as illustrated in the figure above, or tighten to 20 ft-lb.
- Place the remaining Teflon® washer around the other end of the expansion valve. Lightly lubricate connector threads and expose surface of the Teflon® ring with refrigerant oil.
- Attach the liquid line assembly to the expansion valve. Finger tighten and use an appropriately sized wrench to turn an additional 1/2 turn clockwise as illustrated in the figure above or tighten to 20 ft-lb.

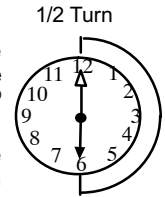

SENSING BULB INSTALLATION

- Attach the vapor line sensing bulb in the proper orientation as illustrated to the right using the clamp and screws provided.
- NOTE** - Confirm proper thermal contact between vapor line and expansion valve sensing bulb before insulating the sensing bulb once installed.
- Connect the equalizer line from the expansion valve to the equalizer vapor port on the vapor line. Finger tighten the flare nut plus 1/8 turn (7 ft-lbs) as illustrated below.

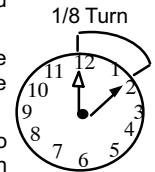

EQUALIZER LINE INSTALLATION

- Remove and discard either the flare seal cap or flare nut with copper flare seal bonnet from the equalizer line port on the vapor line as illustrated in the figure to the right.
- Remove the field-provided fitting that temporarily reconnected the liquid line to the indoor unit's distributor assembly

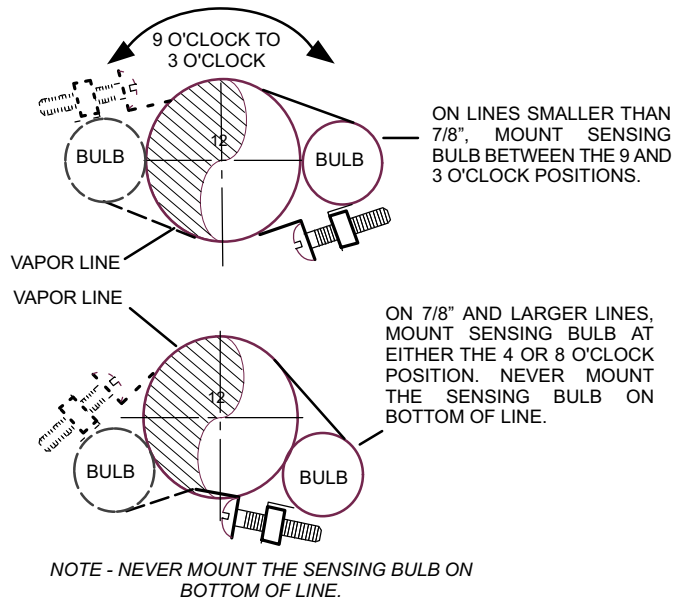
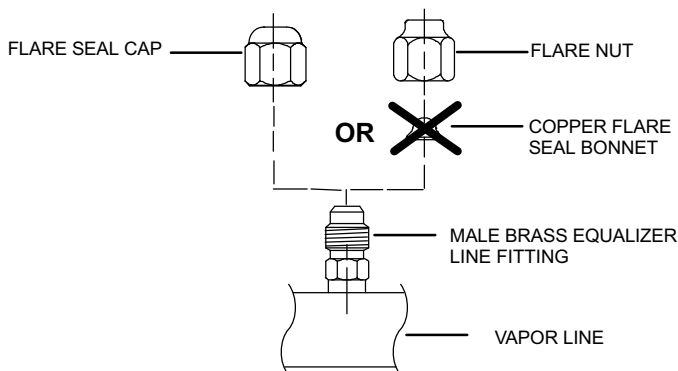

Figure 11. Installing Indoor Expansion Valve

⚠ IMPORTANT

The Environmental Protection Agency (EPA) prohibits the intentional venting of HFC refrigerants during maintenance, service, repair and disposal of appliance. Approved methods of recovery, recycling or reclaiming must be followed.

⚠ IMPORTANT

If this unit is being matched with an approved line set or indoor unit coil which was previously charged with mineral oil, or if it is being matched with a coil which was manufactured before January of 1999, the coil and line set must be flushed prior to installation. Take care to empty all existing traps. Polyol ester (POE) oils are used in Lennox units charged with HFC-410A refrigerant. Residual mineral oil can act as an insulator, preventing proper heat transfer. It can also clog the expansion device, and reduce the system performance and capacity. Failure to properly flush the system per the instructions below will void the warranty.

Leak Test Line Set and Indoor Coil

⚠ WARNING



When using a high pressure gas such as dry nitrogen to pressurize a refrigeration or air conditioning system, use a regulator that can control the pressure down to 1 or 2 psig (6.9 to 13.8 kPa).

⚠ IMPORTANT

Leak detector must be capable of sensing HFC refrigerant.

⚠ WARNING

Refrigerant can be harmful if it is inhaled. Refrigerant must be used and recovered responsibly.

Failure to follow this warning may result in personal injury or death.

1 CONNECT GAUGE SET

- A Connect an HFC-410A manifold gauge set high pressure hose to the vapor valve service port.

NOTE - Normally, the high pressure hose is connected to the liquid line port. However, connecting it to the vapor port better protects the manifold gauge set from high pressure damage.

- B With both manifold valves closed, connect the cylinder of HFC-410A refrigerant to the center port of the manifold gauge set.

NOTE - Later in the procedure, the HFC-410A container will be replaced by the nitrogen container.

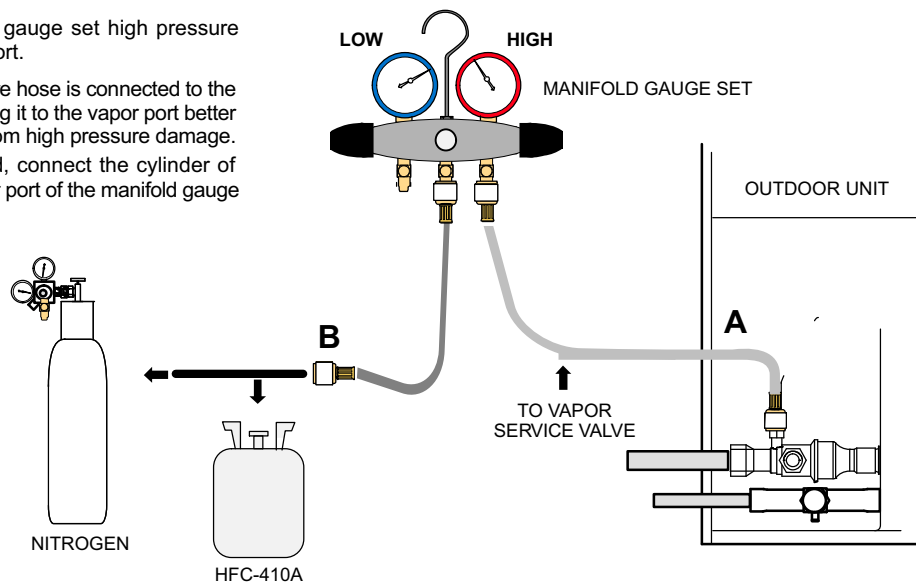

2 TEST FOR LEAKS

After the line set has been connected to the indoor and outdoor units, check the line set connections and indoor unit for leaks. Use the following procedure to test for leaks:

- A With both manifold valves closed, connect the cylinder of HFC-410A refrigerant to the center port of the manifold gauge set. Open the valve on the HFC-410A cylinder (vapor only).
- B Open the high pressure side of the manifold to allow HFC-410A into the line set and indoor unit. Weigh in a trace amount of HFC-410A. [A trace amount is a maximum of two ounces (57 g) refrigerant or three pounds (31 kPa) pressure]. Close the valve on the HFC-410A cylinder and the valve on the high pressure side of the manifold gauge set. Disconnect the HFC-410A cylinder.
- C Connect a cylinder of dry nitrogen with a pressure regulating valve to the center port of the manifold gauge set.
- D Adjust dry nitrogen pressure to 150 psig (1034 kPa). Open the valve on the high side of the manifold gauge set in order to pressurize the line set and the indoor unit.
- E After a few minutes, open one of the service valve ports and verify that the refrigerant added to the system earlier is measurable with a leak detector.
- F After leak testing disconnect gauges from service ports.

Figure 12. Leak Test

Evacuating Line Set and Indoor Coil

1 CONNECT GAUGE SET

NOTE - Remove cores from service valves (if not already done).

- A Connect low side of manifold gauge set with 1/4 SAE in-line tee to vapor line service valve
- B Connect high side of manifold gauge set to liquid line service valve
- C Connect micron gauge available connector on the 1/4 SAE in-line tee.
- D Connect the vacuum pump (with vacuum gauge) to the center port of the manifold gauge set. The center port line will be used later for both the HFC-410A and nitrogen containers.

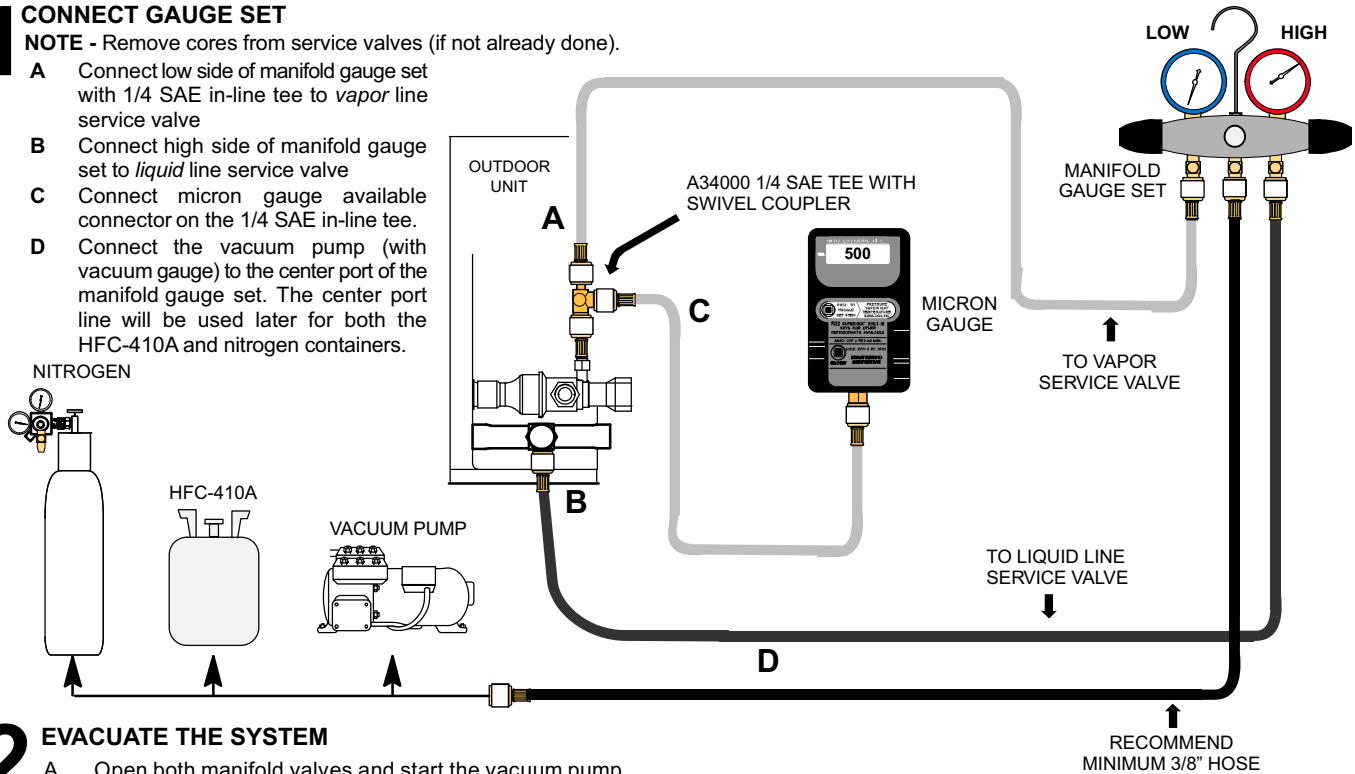

2 EVACUATE THE SYSTEM

- A Open both manifold valves and start the vacuum pump.
- B Evacuate the line set and indoor unit to an **absolute pressure** of 23,000 microns (29.01 inches of mercury).
 - NOTE** - During the early stages of evacuation, it is desirable to close the manifold gauge valve at least once. A rapid rise in pressure indicates a relatively large leak. If this occurs, **repeat the leak testing procedure**.
 - NOTE** - The term **absolute pressure** means the total actual pressure within a given volume or system, above the absolute zero of pressure. Absolute pressure in a vacuum is equal to atmospheric pressure minus vacuum pressure.
- C When the absolute pressure reaches 23,000 microns (29.01 inches of mercury), perform the following:
 - Close manifold gauge valves
 - Close valve on vacuum pump
 - Turn off vacuum pump
 - Disconnect manifold gauge center port hose from vacuum pump
 - Attach manifold center port hose to a dry nitrogen cylinder with pressure regulator set to 150 psig (1034 kPa) and purge the hose.
 - Open manifold gauge valves to break the vacuum in the line set and indoor unit.
 - Close manifold gauge valves.
- D Shut off the dry nitrogen cylinder and remove the manifold gauge hose from the cylinder. Open the manifold gauge valves to release the dry nitrogen from the line set and indoor unit.
- E Reconnect the manifold gauge to the vacuum pump, turn the pump on, and continue to evacuate the line set and indoor unit until the absolute pressure does not rise above 500 microns (29.9 inches of mercury) within a 20-minute period after shutting off the vacuum pump and closing the manifold gauge valves.
- F When the absolute pressure requirement above has been met, disconnect the manifold hose from the vacuum pump and connect it to an upright cylinder of HFC-410A refrigerant. Open the manifold gauge valve 1 to 2 psig in order to release the vacuum in the line set and indoor unit.
- G Perform the following:
 - Close manifold gauge valves.
 - Shut off HFC-410A cylinder.
 - Reinstall service valve cores by removing manifold hose from service valve. Quickly install cores with core tool while maintaining a positive system pressure.
 - Replace stem caps and secure finger tight, then tighten an additional one-sixth (1/6) of a turn as illustrated.

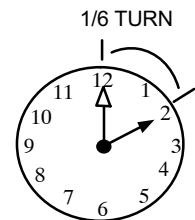

Figure 13. Evacuating System

⚠ IMPORTANT

Use a thermocouple or thermistor electronic vacuum gauge that is calibrated in microns. Use an instrument capable of accurately measuring down to 50 microns.

⚠ WARNING

Danger of Equipment Damage. Avoid deep vacuum operation. Do not use compressors to evacuate a system. Extremely low vacuums can cause internal arcing and compressor failure. Damage caused by deep vacuum operation will void warranty.

Evacuating the system of non-condensables is critical for proper operation of the unit. Non-condensables are defined as any gas that will not condense under temperatures and pressures present during operation of

an air conditioning system. Non-condensables and water suction combine with refrigerant to produce substances that corrode copper piping and compressor parts.

Electrical

In the U.S.A., wiring must conform with current local codes and the current National Electric Code (NEC). In Canada, wiring must conform with current local codes and the current Canadian Electrical Code (CEC).

Refer to the furnace or air handler installation instructions for additional wiring application diagrams and refer to unit nameplate for minimum circuit ampacity and maximum overcurrent protection size.

24VAC TRANSFORMER

Use the transformer provided with the furnace or air handler for low-voltage control power (24VAC - 40 VA minimum)

1 SIZE CIRCUIT AND INSTALL DISCONNECT SWITCH

Refer to the unit nameplate for minimum circuit ampacity, and maximum fuse or circuit breaker (HACR per NEC). Install power wiring and properly sized disconnect switch.

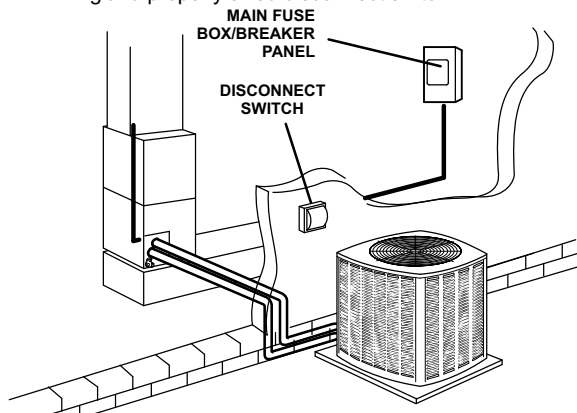

NOTE - Units are approved for use only with copper conductors. Ground unit at disconnect switch or to an earth ground.

2 INSTALL THERMOSTAT

Install room thermostat (ordered separately) on an inside wall approximately in the center of the conditioned area and 5 feet (1.5m) from the floor. It should not be installed on an outside wall or where it can be affected by sunlight or drafts.

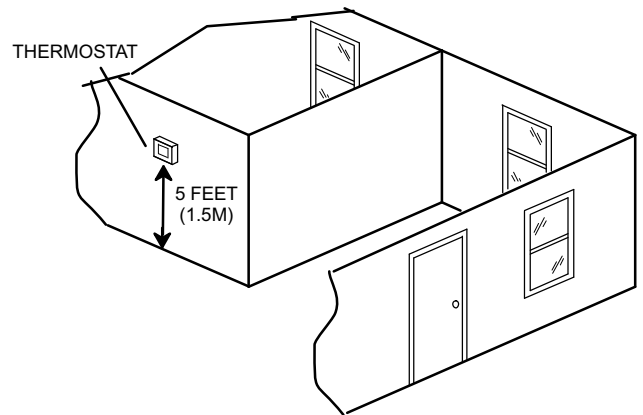

NOTE - 24VAC, Class II circuit connections are made in the control panel.

3 UNIT LOW VOLTAGE CONNECTIONS

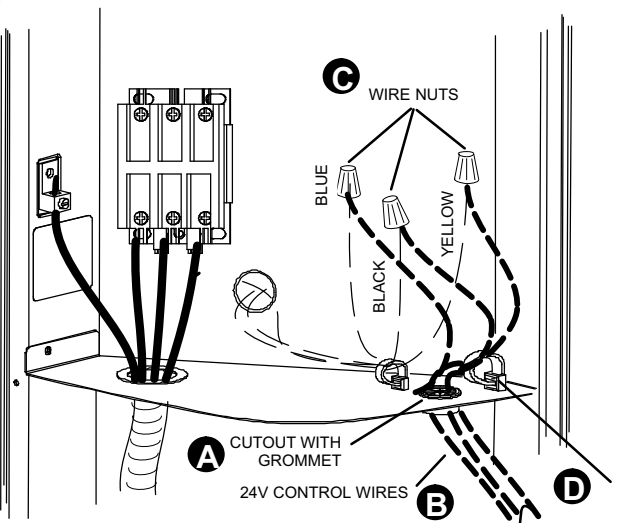

- HIGH VOLTAGE FIELD WIRING
- FACTORY WIRING
- - - LOW VOLTAGE (24V) FIELD WIRING

WIRE RUN LENGTH	AWG#	INSULATION TYPE
LESS THAN 100' (30 METERS)	18	TEMPERATURE RATING
MORE THAN 100' (30 METERS)	16	35°C MINIMUM.

- A** Run 24VAC control wires through cutout with grommet.
- B** Run 24VAC control wires through wire tie.
- C** Make 24VAC control wire connections using field provided wire nuts.
- D** Tighten wire tie to security 24V control wiring.

NOTE - FOR PROPER VOLTAGES, SELECT THERMOSTAT WIRE (CONTROL WIRES) GAUGE PER TABLE ABOVE.

NOTE - WIRE TIE PROVIDES LOW VOLTAGE WIRE STRAIN RELIEF AND TO MAINTAIN SEPARATION OF FIELD INSTALLED LOW AND HIGH VOLTAGE CIRCUITS.

NOTE - DO NOT BUNDLE ANY EXCESS 24VAC CONTROL WIRES INSIDE CONTROL BOX.

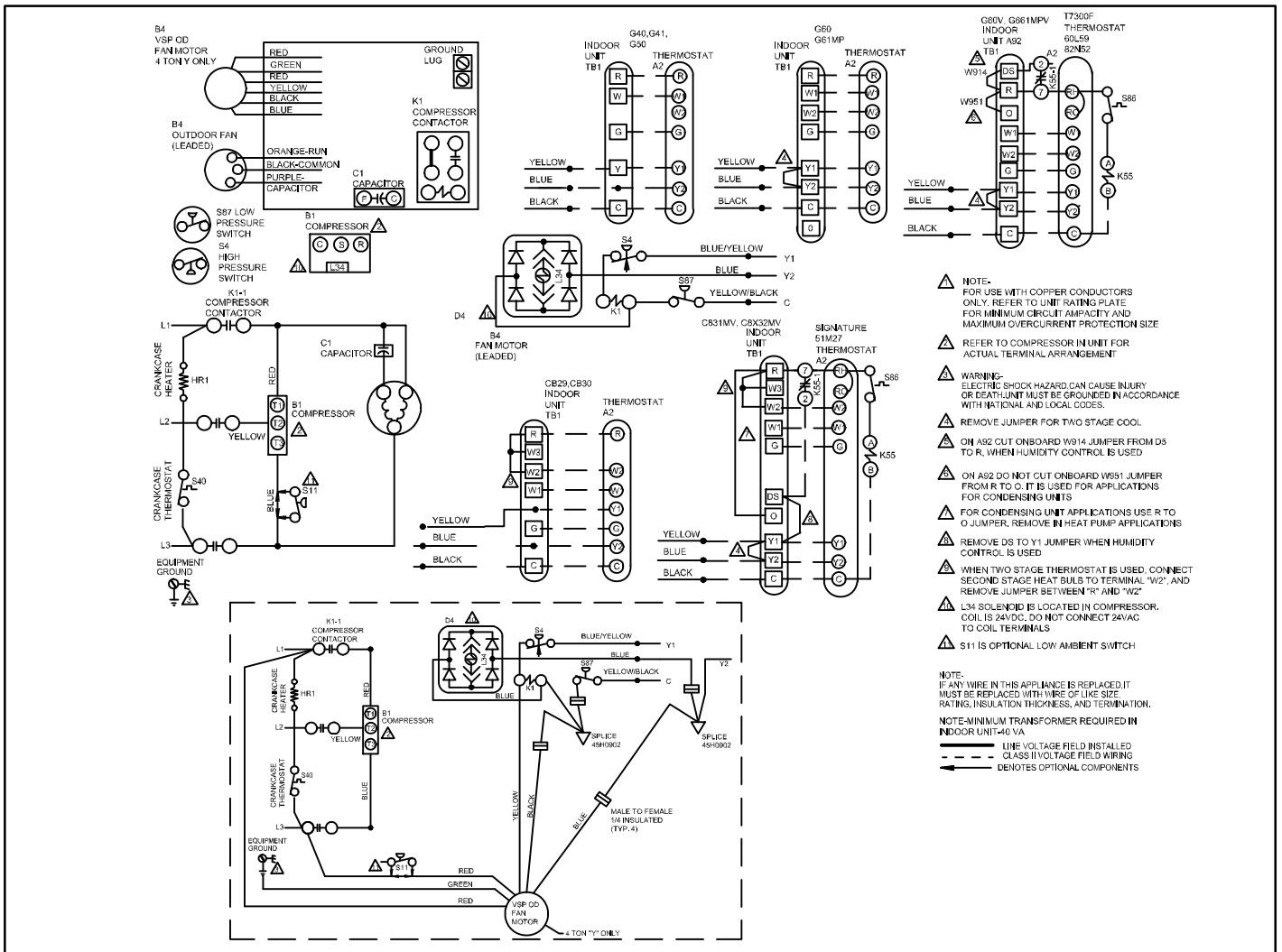

Figure 14. Typical Wiring Diagram (Y-Voltage)

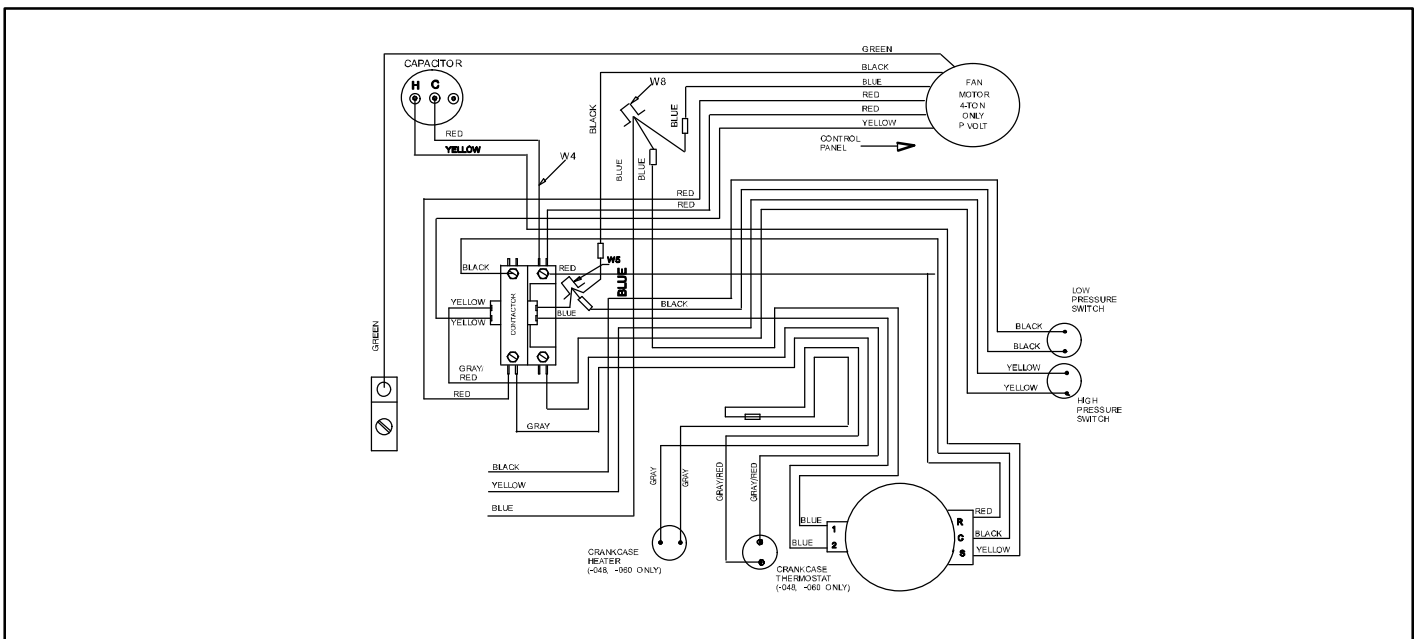

Figure 15. SSB*H4 Typical Factory Diagram (Y-Voltage)

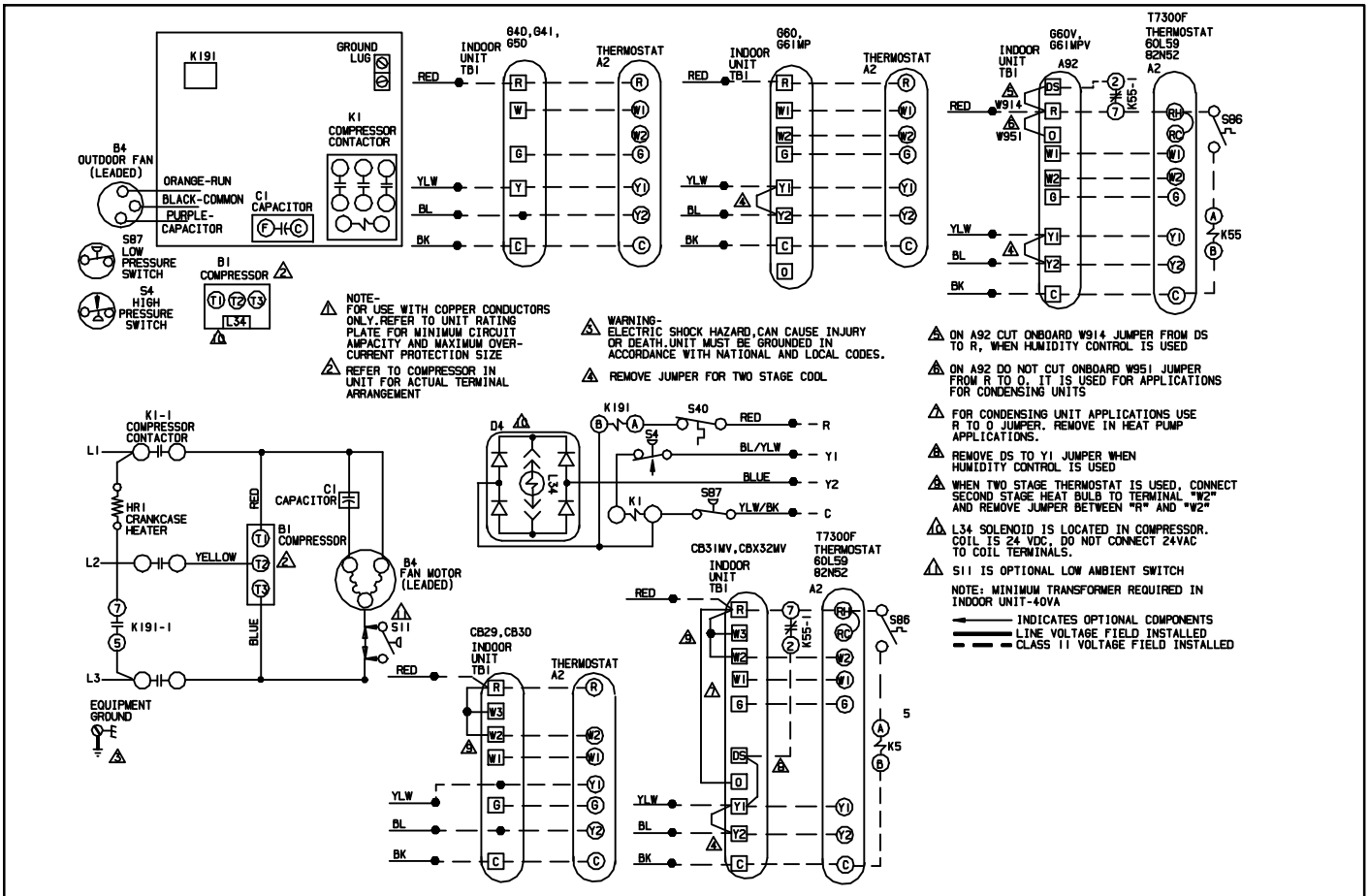

Figure 16. SSB*H4 Typical Wiring Diagram (G-Voltage)

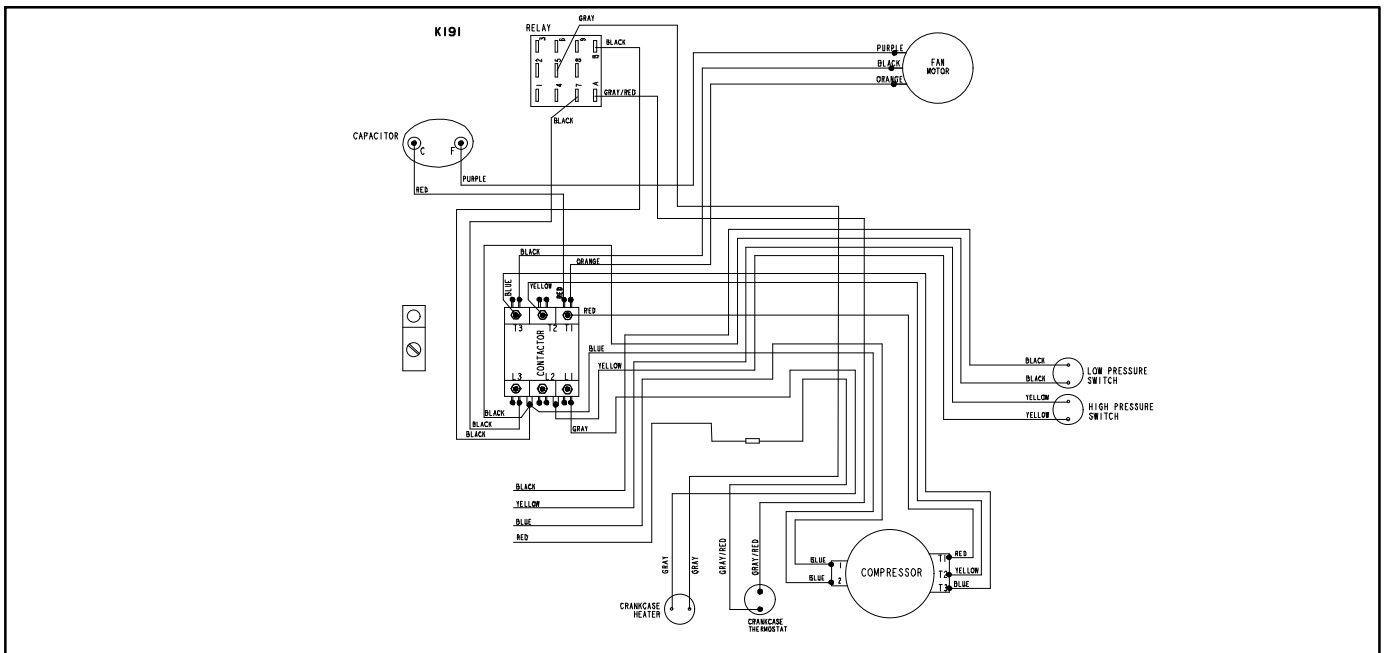

Figure 17. SSB*H4 Typical Factory Diagram (G-Voltage)

Servicing Units Delivered Void of Charge

If the outdoor unit is void of refrigerant, clean the system using the procedure described below.

1. Leak check system using procedure outlined on page 17.
2. Evacuate the system using procedure outlined on page 18.
3. Use nitrogen to break the vacuum and install a new filter drier in the system.
4. Evacuate the system again using procedure outlined on page 18.

5. Weigh in refrigerant using procedure outlined in figure 21.
6. Monitor the system to determine the amount of moisture remaining in the oil. It may be necessary to replace the filter drier several times to achieve the required dryness level. **If system dryness is not verified, the compressor will fail in the future.**

Unit Start-Up

⚠ IMPORTANT

If unit is equipped with a crankcase heater, it should be energized 24 hours before unit start-up to prevent compressor damage as a result of slugging.

1. Rotate fan to check for binding.
2. Inspect all factory- and field-installed wiring for loose connections.
3. After evacuation is complete, open both the liquid and vapor line service valves to release the refrigerant charge contained in outdoor unit into the system.

4. Replace the stem caps and tighten to the value listed in table 1.
5. Check voltage supply at the disconnect switch. The voltage must be within the range listed on the unit's nameplate. If not, do not start the equipment until you have consulted with the power company and the voltage condition has been corrected.
6. Set the thermostat for a cooling demand. Turn on power to the indoor indoor unit and close the outdoor unit disconnect switch to start the unit.
7. Recheck voltage while the unit is running. Power must be within range shown on the nameplate.
8. Check system for sufficient refrigerant by using the procedures listed under *System Charge*.

System Refrigerant

This section outlines procedures for:

1. Connecting gauge set for testing and charging;
2. Checking and adjusting indoor airflow;
3. Adding or removing refrigerant.

GAUGE SET

CONNECTIONS FOR TESTING AND CHARGING

- A Close manifold gauge set valves and connect the center hose to a cylinder of HFC-410A. Set for liquid phase charging.
- B Connect the manifold gauge set's low pressure side to the suction line service port.
- C Connect the manifold gauge set's high pressure side to the liquid line service port.
- D Position temperature sensor on liquid line near liquid line service port.

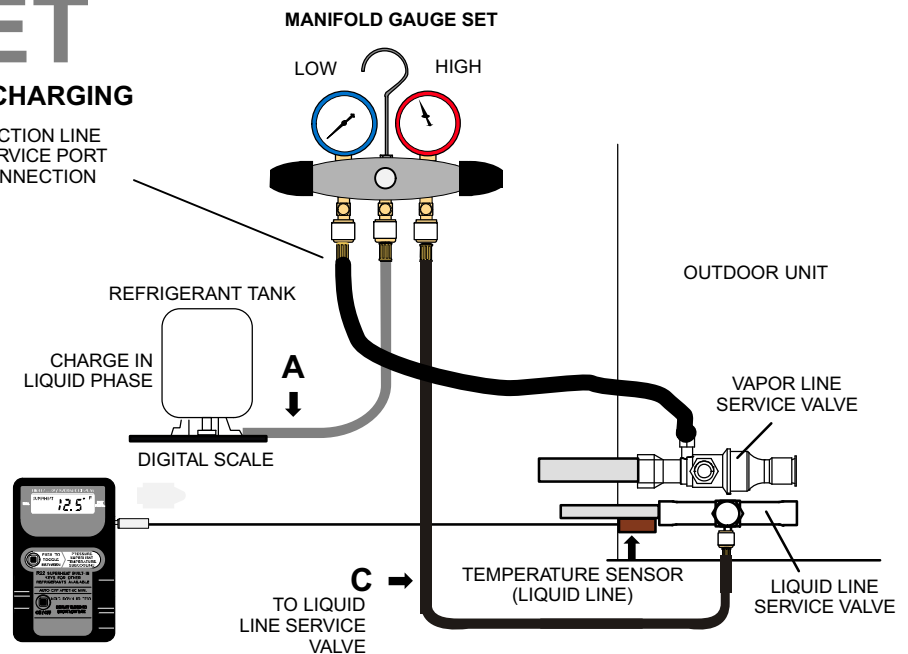

Figure 18. Gauge Set Setup and Connections

CHECKING AIR FLOW AT INDOOR COIL

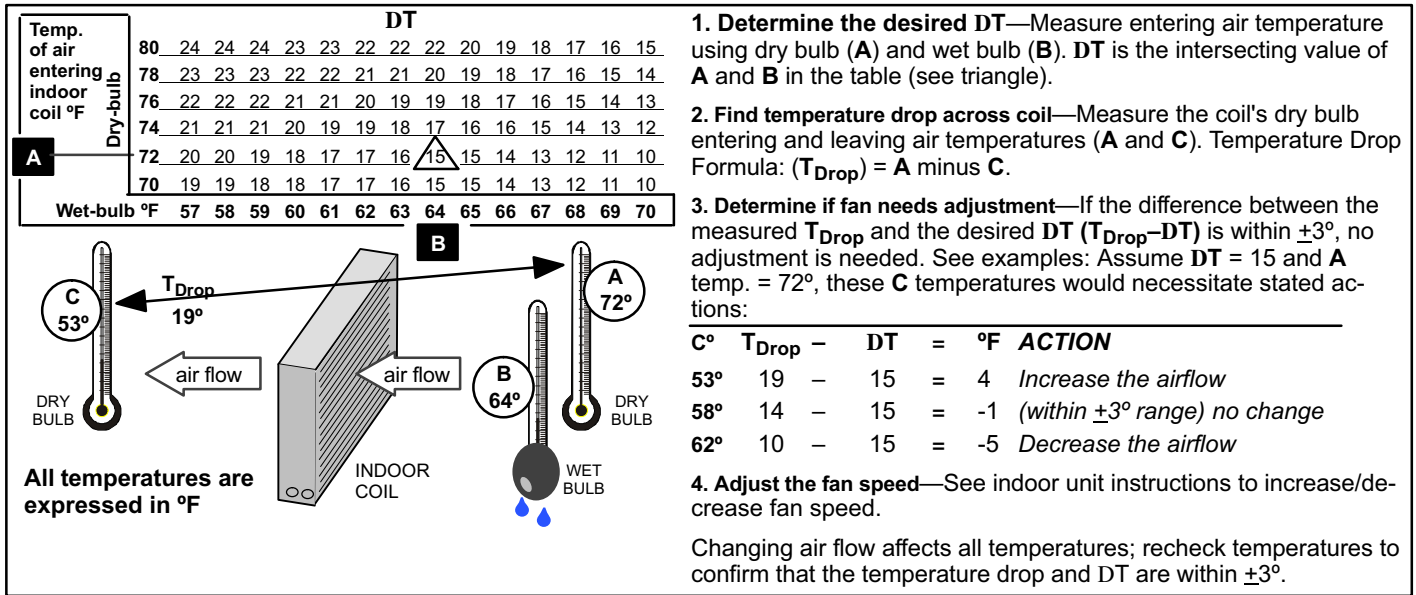

Figure 19. Checking Indoor Airflow over Evaporator Coil using Delta-T Chart

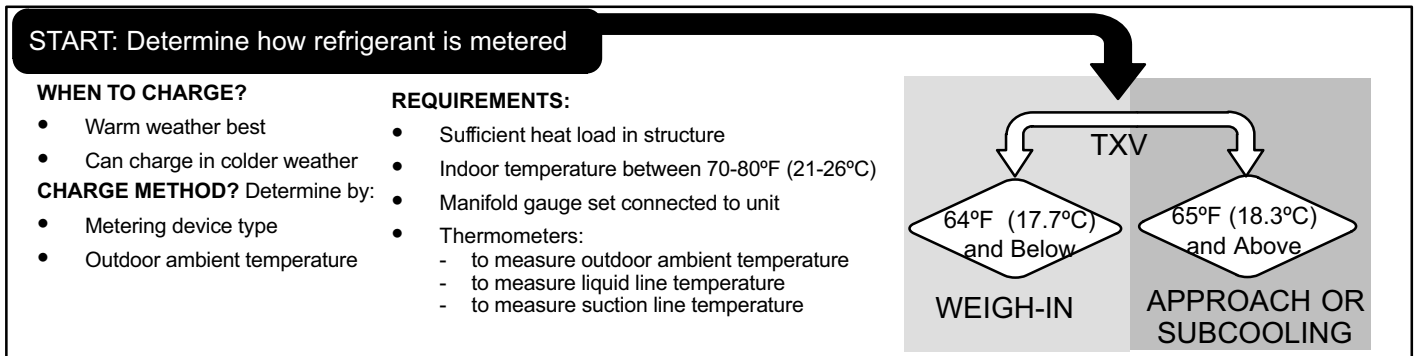

Figure 20. Determining Charge Method

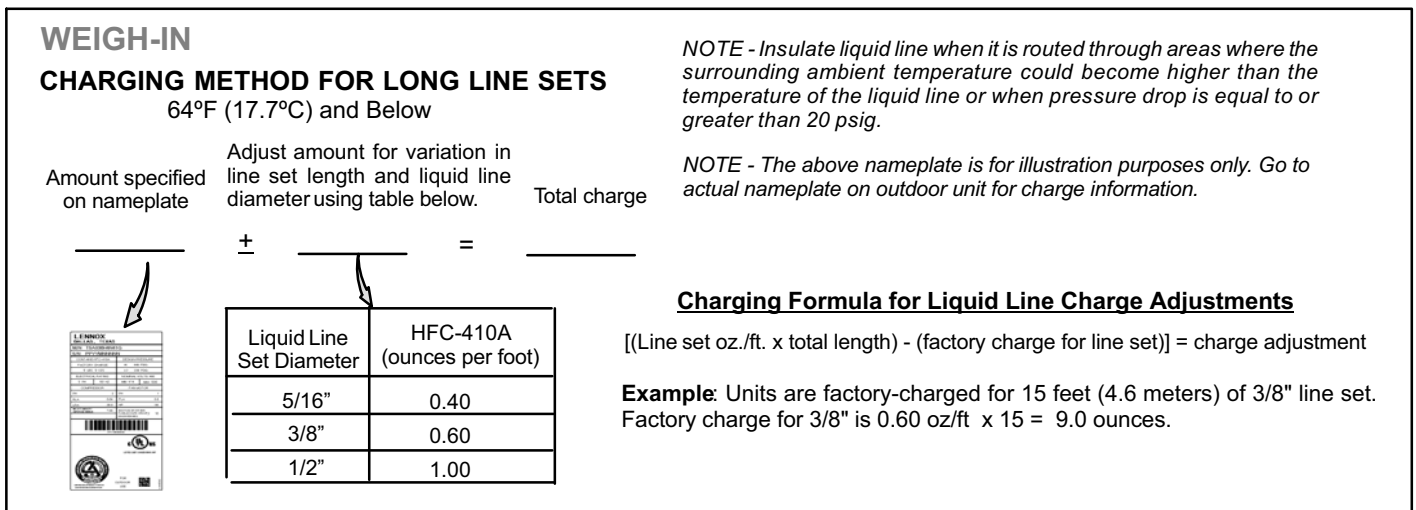

Figure 21. Using HFC-410A Weigh-In Method

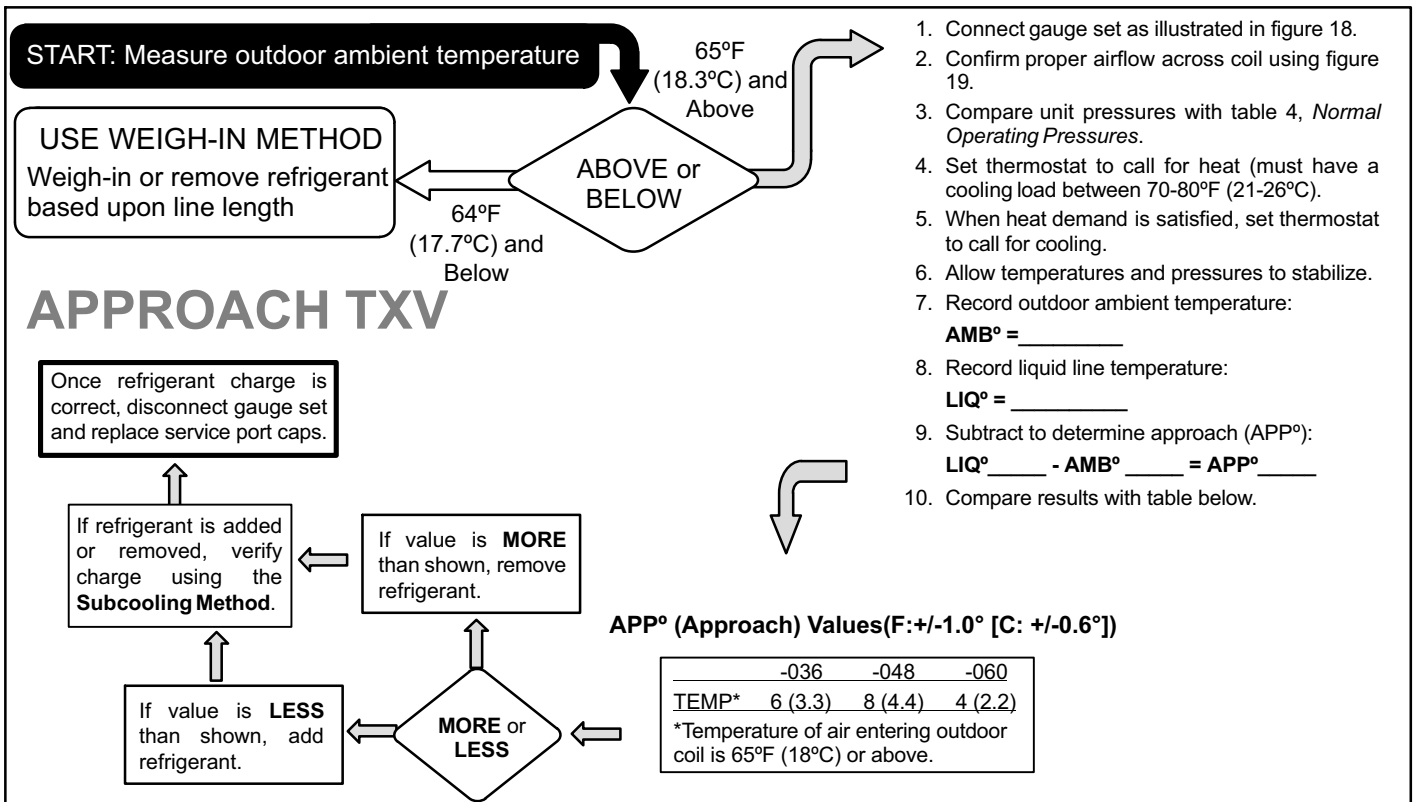

Figure 22. Using HFC-410A Approach (TXV) Charge Method

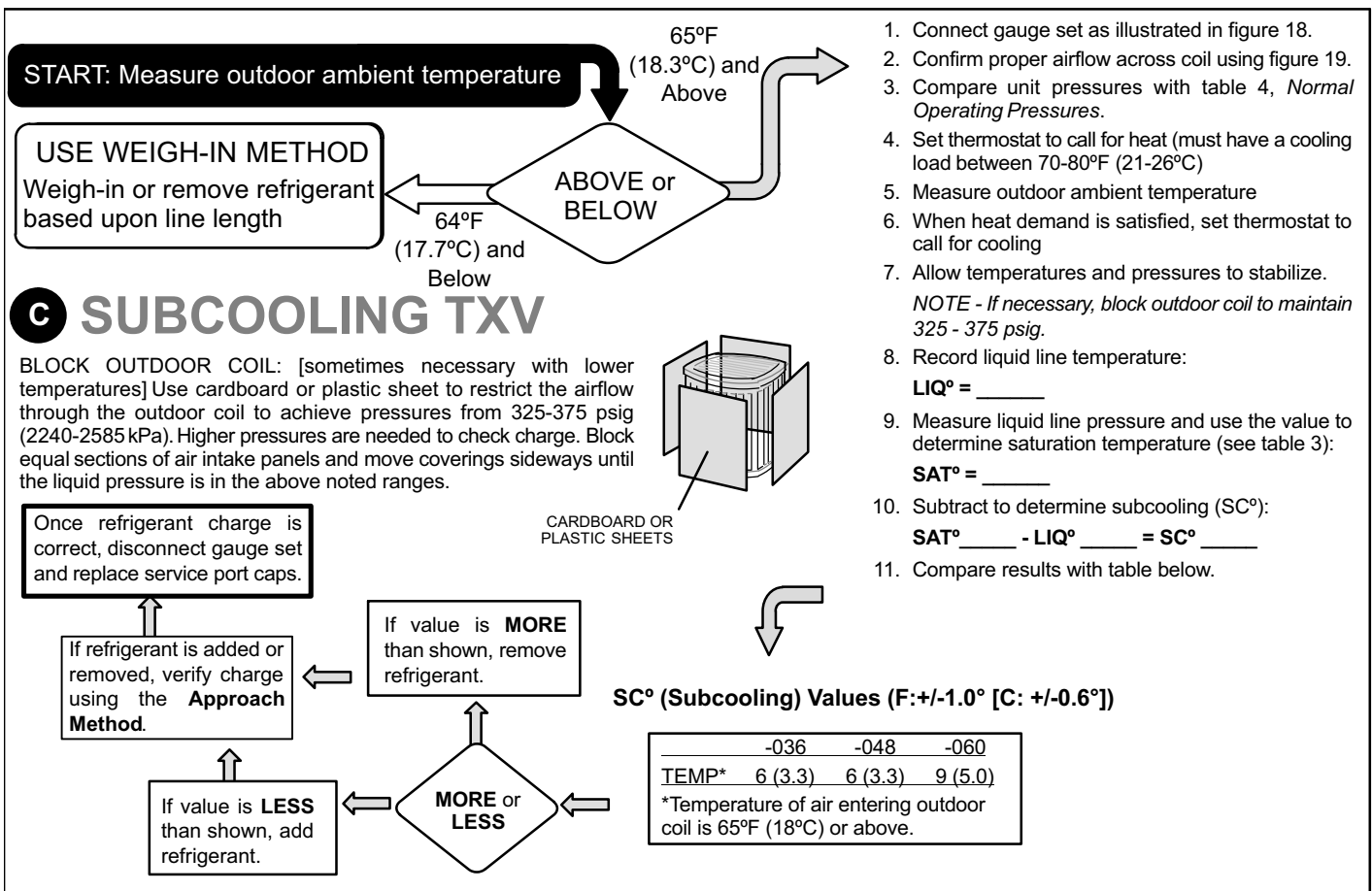

Figure 23. Using HFC-410A Subcooling (TXV) Charge Method

Table 3. HFC-410A Temperature (°F) - Pressure (Psig)

°F	Psig	°F	Psig	°F	Psig	°F	Psig	°F	Psig	°F	Psig	°F	Psig	°F	Psig
32	100.8	48	137.1	63	178.5	79	231.6	94	290.8	110	365.0	125	445.9	141	545.6
33	102.9	49	139.6	64	181.6	80	235.3	95	295.1	111	370.0	126	451.8	142	552.3
34	105.0	50	142.2	65	184.3	81	239.0	96	299.4	112	375.1	127	457.6	143	559.1
35	107.1	51	144.8	66	187.7	82	242.7	97	303.8	113	380.2	128	463.5	144	565.9
36	109.2	52	147.4	67	190.9	83	246.5	98	308.2	114	385.4	129	469.5	145	572.8
37	111.4	53	150.1	68	194.1	84	250.3	99	312.7	115	390.7	130	475.6	146	579.8
38	113.6	54	152.8	69	197.3	85	254.1	100	317.2	116	396.0	131	481.6	147	586.8
39	115.8	55	155.5	70	200.6	86	258.0	101	321.8	117	401.3	132	487.8	148	593.8
40	118.0	56	158.2	71	203.9	87	262.0	102	326.4	118	406.7	133	494.0	149	601.0
41	120.3	57	161.0	72	207.2	88	266.0	103	331.0	119	412.2	134	500.2	150	608.1
42	122.6	58	163.9	73	210.6	89	270.0	104	335.7	120	417.7	135	506.5	151	615.4
43	125.0	59	166.7	74	214.0	90	274.1	105	340.5	121	423.2	136	512.9	152	622.7
44	127.3	60	169.6	75	217.4	91	278.2	106	345.3	122	428.8	137	519.3	153	630.1
45	129.7	61	172.6	76	220.9	92	282.3	107	350.1	123	434.5	138	525.8	154	637.5
46	132.2	62	175.4	77	224.4	93	286.5	108	355.0	124	440.2	139	532.4	155	645.0
47	134.6			78	228.0			109	360.0			140	539.0		

Table 4. Normal Operating Pressures (Liquid +10 and Suction +5 psig)

⚠ IMPORTANT	Use this table to perform maintenance checks; it is not a procedure for charging the system. Minor variations in these pressures may be due to differences in installations. Significant deviations could mean that the system is not properly charged or that a problem exists with some component in the system.
--------------------	--

Model	SSB036H4S4		SSB048H4S4		SSB060H4S4	
°F (°C)*	Liquid	Suction	Liquid	Suction	Liquid	Suction
First Stage (Low Capacity)						
65 (18)	217	141	229	140	229	134
75 (24)	251	143	263	143	264	138
85 (29)	292	146	304	146	305	140
95 (35)	337	147	350	148	349	142
105 (41)	387	150	400	150	402	147
115 (46)	440	154	453	155	455	149
Second Stage (High Capacity)						
65 (18)	230	137	234	135	244	129
75 (24)	265	140	269	137	282	131
85 (29)	307	141	312	140	324	133
95 (35)	354	144	359	141	371	136
105 (41)	405	146	409	143	422	139
115 (46)	460	149	465	146	474	143

*Temperature of air entering outdoor coil.
 **(Liquid ±10 psig; Vapor ±5 psig) Typical pressures; indoor unit match up, indoor air quality equipment, and indoor load will cause the pressures to vary.

System Operation

SECOND-STAGE OPERATION

If the demand defrost control (A108) receives a call for second-stage compressor operation Y2 in heating or cooling mode and the first-stage compressor output is active, the second-stage compressor solenoid output will be energized.

If first-stage compressor output is active in heating mode and the outdoor ambient temperature is below the selected compressor lock-in temperature, the second-stage compressor solenoid output will be energized without the Y2 input. If the jumper is not connected to one of the temperature selection pins on **P3** (40, 45, 50, 55°F), the default lock-in temperature of 40°F (4.5°C) will be used.

⚠ IMPORTANT
Some scroll compressor have internal vacuum protector that will unload scrolls when suction pressure goes below 20 psig. A hissing sound will be heard when the compressor is running unloaded. Protector will reset when low pressure in system is raised above 40 psig. DO NOT REPLACE COMPRESSOR.

UNIT COMPONENTS

High Pressure Switch (S4)

This unit now employs a automatic pressure switch located on the liquid line of the compressor. The pressure switch (SPST, auto-reset, normally closed) removes power from the compressor when liquid pressure rises above factory setting (opens at 590 ± 15 psig and closes at 418 ± 15 psig).

Low Pressure Switch (S87)

SSB*H4 units are also equipped with a low pressure switch that is located in the vapor line of the compressor. The switch (SPST, auto-reset, normally closed) removes power from the compressor when vapor line pressure drops below factory setting at 40 ± 5 psi.

Crankcase Heater Relay (K191) (G Voltage Units Only)

All 460 volt SSB units require the S40 thermostat to be wired in series with the 24 volt coil of the K191 relay. The contacts of the K191 control operation of crankcase heater HR1. When ambient temperature drops below 50° F, K191 contacts close energizing HR1. When the ambient temperature rises to 70° F the contacts open de-energizing HR1.

Crankcase Heater (HR1) and Crankcase Thermostat (S40)

The reference models are equipped with a 70 watt, belly band type crankcase heater. HR1 prevents liquid from accumulating in the compressor. HR1 is controlled by a thermostat located on the liquid line. When liquid line temperature drops below 50° F the thermostat closes energizing HR1. The thermostat will open, de-energizing HR1 once liquid line temperature reaches 70° F.

Internal Solenoid (L34)

The internal unloader solenoid controls the two-stage operation of the compressor by shifting a slide ring mechanism to open two by-pass ports in the first compression pocket of the scrolls in the compressor. The internal solenoid is activated by a 24 volt direct current solenoid coil. The coil power requires 20VAC. The internal wires from the solenoid in the compressor are routed to a 2 pin fusite connection on the side of the compressor shell. The external electrical connection is made to the compressor with a molded plug assembly. This plug contains a full wave rectifier that converts 24 volt AC into 24 volt DC power to power the unloader solenoid. Refer to unit diagram for internal circuitry view of plug).

Liquid Line Bi-Flow Filter Drier

The unit is equipped with a large-capacity biflow filter drier which keeps the system clean and dry. If replacement is necessary, order another of like design and capacity. The replacement filter drier must be suitable for use with HFC-410A refrigerant.

Maintenance

DEALER

Maintenance and service must be performed by a qualified installer or service agency. At the beginning of each cooling season, the system should be checked as follows:

Outdoor Unit

1. Clean and inspect the outdoor coil. The coil may be flushed with a water hose. Ensure the power is turned off before you clean the coil.
2. Outdoor fan motor is prelubricated and sealed. No further lubrication is needed.
3. Visually inspect connecting lines and coils for evidence of oil leaks.
4. Check wiring for loose connections.
5. Check for correct voltage at the unit (with the unit operating).
6. Check amp-draw outdoor fan motor.

UNIT NAMEPLATE: _____ ACTUAL: _____

NOTE - If owner reports insufficient cooling, the unit should be gauged and refrigerant charge checked.

Outdoor Coil

It may be necessary to flush the outdoor coil more frequently if it is exposed to substances which are corrosive or which block airflow across the coil (e.g., pet urine, cottonwood seeds, fertilizers, fluids that may contain high levels of corrosive chemicals such as salts)

- Outdoor Coil — The outdoor coil may be flushed with a water hose.
- Outdoor Coil (Sea Coast) — Moist air in ocean locations can carry salt, which is corrosive to most metal. Units that are located near the ocean require frequent inspections and maintenance. These inspections will determine the necessary need to wash the unit including the outdoor coil. Consult your installing contractor for proper intervals/procedures for your geographic area or service contract.

INDOOR UNIT

1. Clean or change filters.
2. Adjust blower speed for cooling. Measure the pressure drop over the coil to determine the correct blower CFM. Refer to the unit information service manual for pressure drop tables and procedure.
3. Check blower drive belt for wear and proper tension.
4. Check all wiring for loose connections
5. Check for correct voltage at unit (blower operating).
6. Check amp-draw on blower motor.

UNIT NAMEPLATE: _____ ACTUAL: _____

INDOOR COIL

1. Clean coil, if necessary.
2. Check connecting lines and coils for signs of oil leaks.
3. Check condensate line and clean, if necessary.

OWNER

Cleaning of the outdoor unit's coil should be performed by a trained service technician. Contact your dealer and set up a schedule (preferably twice a year, but at least once a year) to inspect and service your outdoor unit. The following maintenance may be performed by the homeowner.

IMPORTANT

Sprinklers and soaker hoses should not be installed where they could cause prolonged exposure to the outdoor unit by treated water. Prolonged exposure of the unit to treated water (i.e., sprinkler systems, soakers, waste water, etc.) will corrode the surface of steel and aluminum parts and diminish performance and longevity of the unit.

Outdoor Coil

The outdoor unit must be properly maintained to ensure its proper operation.

- Please contact your dealer to schedule proper inspection and maintenance for your equipment.
- Make sure no obstructions restrict airflow to the outdoor unit.
- Grass clippings, leaves, or shrubs crowding the unit can cause the unit to work harder and use more energy.
- Keep shrubbery trimmed away from the unit and periodically check for debris which collects around the unit.

Cleaning of the outdoor unit's coil should be performed by a trained service technician. Contact your dealer and set up a schedule (preferably twice a year, but at least once a year) to inspect and service your outdoor unit.

Routine Maintenance

In order to ensure peak performance, your system must be properly maintained. Clogged filters and blocked airflow prevent your unit from operating at its most efficient level.

1. **Air Filter** — Ask your Lennox dealer to show you where your indoor unit's filter is located. It will be either at the indoor unit (installed internal or external to the cabinet) or behind a return air grille in the wall or ceiling. Check the filter monthly and clean or replace it as needed.

Checklists

Use the following checklist to verify part-load and full-load capacity operation of two-stage modulation compressors.

TOOLS REQUIRED

- Refrigeration gauge set
- Digital volt/amp meter
- Electronic temperature thermometer
- On-off toggle switch

2. **Disposable Filter** — Disposable filters should be replaced with a filter of the same type and size.

NOTE - If you are unsure about the filter required for your system, call your Lennox dealer for assistance.

3. **Reusable Filter** — Many indoor units are equipped with reusable foam filters. Clean foam filters with a mild soap and water solution; rinse thoroughly; allow filter to dry completely before returning it to the unit or grille.

NOTE - The filter and all access panels must be in place any time the unit is in operation.

4. **Indoor Unit** — The indoor unit's evaporator coil is equipped with a drain pan to collect condensate formed as your system removes humidity from the inside air. Have your dealer show you the location of the drain line and how to check for obstructions. (This would also apply to an auxiliary drain, if installed.)

Thermostat Operation

See the thermostat homeowner manual for instructions on how to operate your thermostat.

Preservice Check

If your system fails to operate, check the following before calling for service:

- Verify room thermostat settings are correct.
- Verify that all electrical disconnect switches are ON.
- Check for any blown fuses or tripped circuit breakers.
- Verify unit access panels are in place.
- Verify air filter is clean.
- If service is needed, locate and write down the unit model number and have it handy before calling.

Accessories

For update-to-date information, see any of the following publications:

- Lennox SSB*H4 Product Specification bulletin
- Lennox Product Catalog
- Lennox Price Book

IMPORTANT

This performance check is **ONLY** valid on systems that have clean indoor and outdoor coils, proper airflow over coils, and correct system refrigerant charge. All components in the system must be functioning properly to correctly perform compressor operational check. (Accurate measurements are critical to this test as indoor system loading and outdoor ambient can affect variations between low and high capacity readings).

Two-Stage Modulation Compressors Field Operational Checklist

Unit Readings	Y1 - First-Stage	Expected results during Y2 demand (Toggle switch On)	Y2 - Second-Stage
COMPRESSOR			
Voltage		Same	
Amperage		Higher	
OUTDOOR UNIT FAN MOTOR			
Amperage		Same or Higher	
TEMPERATURE			
Ambient		Same	
Outdoor Coil Discharge Air		Higher	
Compressor Discharge Line		Higher	
Indoor Return Air		Same	
Indoor Coil Discharge Air		Lower	
PRESSURES			
Suction (Vapor)		Lower	
Liquid		Higher	

Start-Up and Performance Checklist

Job Name _____	Job no. _____	Date _____
Job Location _____	City _____	State _____
Installer _____	City _____	State _____
Unit Model No. _____	Serial No. _____	Service Technician _____
Nameplate Voltage _____		
Rated Load Ampacity _____	Compressor _____	Outdoor Fan _____
Maximum Fuse or Circuit Breaker _____		
Electrical Connections Tight? <input type="checkbox"/>	Indoor Filter clean? <input type="checkbox"/>	Supply Voltage (Unit Off) _____
Indoor Blower RPM _____	S.P. Drop Over Indoor (Dry) _____	Outdoor Coil Entering Air Temp. _____
Discharge Pressure _____	Suction Pressure _____	Refrigerant Charge Checked? <input type="checkbox"/>
Refrigerant Lines: - Leak Checked? <input type="checkbox"/>	Properly Insulated? <input type="checkbox"/>	Outdoor Fan Checked? <input type="checkbox"/>
Service Valves: --- Fully Opened? <input type="checkbox"/>	Caps Tight? <input type="checkbox"/>	Thermostat
Voltage With Compressor Operating _____	Calibrated? <input type="checkbox"/> Properly Set? <input type="checkbox"/> Level? <input type="checkbox"/>	