

High Efficiency LDT024 through 060

LDT024, 036, 048, and 060 are high efficiency packaged units equipped with variable speed direct drive blowers, a two-speed compressor, and a variable speed outdoor fan.

LDT024 units are available in 65,000 Btuh (19 kW) heating inputs. LDT036 are available in 65,000 to 108,000 Btuh (19 to 31 kW). LDT048 and 060 units are available in 65,000 to 150,000 Btuh (19 to 43.9 kW) heating inputs. LDT072 units are available in 65,000 to 150,000 Btuh (19 to 43.9 kW) heating inputs. Gas heat sections are designed with aluminized (stainless optional) steel tube heat exchangers. Cooling capacities range from 2 to 5 tons (7 to 17.5kW).

Information contained in this manual is intended for use by qualified service technicians only. All specifications are subject to change. Procedures outlined in this manual are presented as a recommendation only and do not supersede or replace local or state codes.

If the unit must be lifted for service, rig unit by attaching four cables to the holes located in the unit base rail (two holes at each corner). Refer to the installation instructions for the proper rigging technique.

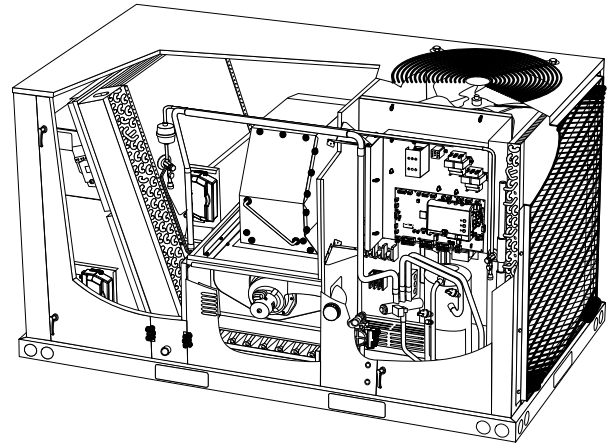

⚠ WARNING

Improper installation, adjustment, alteration, service or maintenance can cause property damage, personal injury or loss of life. Installation and service must be performed by a licensed professional installer (or equivalent), service agency or the gas supplier.

⚠ IMPORTANT

The Clean Air Act of 1990 bans the intentional venting of refrigerant (CFC's and HCFC's) as of July 1, 1992. Approved methods of recovery, recycling or reclaiming must be followed. Fines and/or incarceration may be levied for non-compliance.

⚠ WARNING



Electric shock hazard. Can cause injury or death. Before attempting to perform any service or maintenance, turn the electrical power to unit OFF at disconnect switch(es). Unit may have multiple power supplies.

⚠ WARNING

To prevent serious injury or death:

- 1- Lock-out/tag-out before performing maintenance.
- 2- If system power is required (e.g., smoke detector maintenance), disable power to blower, remove fan belt where applicable, and ensure all controllers and thermostats are set to the "OFF" position before performing maintenance.
- 3- Always keep hands, hair, clothing, jewelry, tools, etc., away from moving parts.

⚠ CAUTION

As with any mechanical equipment, contact with sharp sheet metal edges can result in personal injury. Take care while handling this equipment and wear gloves and protective clothing.

Table of Contents

Options	Page 2
Specifications	Page 6
High Altitude	Page 6
Blower Data	Page 8
Electrical Data	Page 14
I Unit Components	Page 18
II Placement and Installation	Page 33
III Start Up Operation	Page 33
IV Charging	Page 34
V System Service Checks	Page 36
VI Maintenance	Page 38
VII Accessories	Page 40
VIII Diagrams	Page 47

OPTIONS / ACCESSORIES

Item	Catalog Number	Unit Model Number				
		024	036	048	060	
COOLING SYSTEM						
Condensate Drain Trap	PVC	22H54	OX	OX	OX	OX
	Copper	76W27	OX	OX	OX	OX
Drain Pan Overflow Switch		21Z07	OX	OX	OX	OX
HEATING SYSTEM						
Bottom Gas Piping Kit		19W50	OX	OX	OX	OX
Combustion Air Intake Extensions		19W51	X	X	X	X
Gas Heat (Low NOx) Input	Standard Two-Stage- 53/65 kBtuh input	Factory	O	O	O	O
	Medium Two-Stage - 81/108 kBtuh input	Factory	O	O	O	O
	High Two-Stage - 113/150 kBtuh input	Factory			O	O
Low Temperature Vestibule Heater	208/230V-1 or 3ph	21Z17	X	X	X	X
	460V-3ph	21Z18		X	X	X
	575V-3ph	21Z19		X	X	X
LPG/Propane Conversion Kits	For two-stage standard models	21Z24	X	X	X	X
	For two-stage medium and high models	21Z23	X	X	X	X
Stainless Steel Heat Exchanger		Factory	O	O	O	O
Vertical Vent Extension		31W62	X	X	X	X
BLOWER - SUPPLY AIR						
Motors - Standard Static (All voltages)	Direct Drive ECM Blower - 0.50 hp	Factory	O	O		
	1.0 hp	Factory			O	O
Motors - High Static (3 phase only)	DirectPlus™ Direct Drive ECM Blower System with MSAV® - 1.5 hp	Factory			O	O
CABINET						
Combination Coil/Hail Guards		13T03	OX	OX	OX	OX
Corrosion Protection		Factory	O	O	O	O
CONTROLS						
Blower Proving Switch		21Z10	OX	OX	OX	OX
Commercial Controls	CPC Einstein Integration	Factory	O	O	O	O
	LonTalk® Module	54W27	OX	OX	OX	OX
	Novar® LSE	Factory	O	O	O	O
Dirty Filter Switch		53W66	OX	OX	OX	OX
Fresh Air Tempering		21Z08	OX	OX	OX	OX
Smoke Detector - Supply or Return (Power board and one sensor)		21Z11	OX	OX	OX	OX
Smoke Detector - Supply and Return (Power board and two sensors)		21Z12	OX	OX	OX	OX

NOTE - Catalog numbers shown are for ordering field installed accessories.

OX - Configure To Order (Factory Installed) or Field Installed

O = Configure To Order (Factory Installed)

X = Field Installed

OPTIONS / ACCESSORIES

Item	Catalog Number	Unit Model Number				
		024	036	048	060	
ELECTRICAL						
Voltage	208/230V - 1 phase	Factory	O	O	O	O
60 Hz	208/230V - 3 phase	Factory		O	O	O
	460V - 3 phase	Factory		O	O	O
	575V - 3 phase	Factory		O	O	O
HACR Circuit Breakers		Factory	O	O	O	O
¹ Short-Circuit Current Rating (SCCR) of 100kA (includes Phase/Voltage Detection)		Factory	O	O	O	O
Disconnect Switch	80 amp	22A25	OX	OX	OX	OX
GFI Service Outlets	15 amp non-powered, field-wired (208/230V, 460V only)	74M70	OX	OX	OX	OX
	15 amp factory-wired and powered (208/230V, 460V only)	Factory	O	O	O	O
	² 20 amp non-powered, field-wired (208/230V, 460V, 575V)	67E01	X	X	X	X
	² 20 amp non-powered, field-wired (575V)	Factory		O	O	O
Weatherproof Cover for GFI		10C89	X	X	X	X
Phase/Voltage Detection - 3 Phase Models Only		Factory		O	O	O
ECONOMIZER						
High Performance Economizer With Outdoor Air Hood (Sensible Control) (Approved for California Title 24 Building Standards / AMCA Class 1A Certified)						
High Performance Economizer - Includes Barometric Relief Dampers and Combination Hood		20H48	OX	OX	OX	OX
High Performance Economizer - No Exhaust Option		Factory	O	O	O	O
Economizer Accessories						
Horizontal Economizer Conversion Kit		17W45	X	X	X	X
Economizer Controls (Not for Title 24)						
Differential Enthalpy	Order 2	21Z09	OX	OX	OX	OX
Sensible Control	Sensor is Furnished	Factory	O	O	O	O
Outdoor Air CFM Control		13J76	X	X	X	X
Single Enthalpy		21Z09	OX	OX	OX	OX
Global Control	Sensor Field Provided	Factory	O	O	O	O
Building Pressure Control		13J77	X	X	X	X
POWER EXHAUST FAN						
Standard Static	208/230V-1 or 3ph	21Z13	OX	OX	OX	OX
<i>NOTE - Factory or Field installed Power Exhaust Fan requires "Barometric Relief Dampers for Power Exhaust Kit" for field installation. See below.</i>	460V-3ph	21Z14		OX	OX	OX
	575V-3ph	21Z15		OX	OX	OX
BAROMETRIC RELIEF						
³ Barometric Relief Dampers for Power Exhaust Kit		21Z21	X	X	X	X
⁴ Horizontal Barometric Relief Dampers With Exhaust Hood		19F01	X	X	X	X
OUTDOOR AIR						
Outdoor Air Dampers With Outdoor Air Hood						
Motorized		15D17	OX	OX	OX	OX
Manual		15D18	X	X	X	X

¹ Disconnect Switch is furnished and factory installed with High SCCR option.

² Canada requires a minimum 20 amp circuit. Select 20 amp, non-powered, field wired GFI.

³ Required when Economizer is factory installed with factory installed Power Exhaust Fan option.

⁴ Required when Economizer is configured for horizontal airflow.

NOTE - Catalog numbers shown are for ordering field installed accessories.

OX = Configure To Order (Factory Installed) or Field Installed

O = Configure To Order (Factory Installed)

X = Field Installed

OPTIONS / ACCESSORIES

Item	Catalog Number	Unit Model Number				
		024	036	048	060	
INDOOR AIR QUALITY						
Air Filters						
Healthy Climate® High Efficiency Air Filters 20 x 20 x 2 in.	MERV 8 (Order 4)	54W21	OX	OX	OX	OX
	MERV 13 (Order 4)	52W39	OX	OX	OX	OX
	MERV 16 (Order 4)	21U40	OX	OX	OX	OX
Replaceable Media Filter With Metal Mesh Frame (includes non-pleated filter media)	20 x 20 x 2 in. (Order 4)	44N60	X	X	X	X
Indoor Air Quality (CO₂) Sensors						
Sensor - Wall-mount, off-white plastic cover with LCD display		77N39	X	X	X	X
Sensor - Wall-mount, off-white plastic cover, no display		87N53	X	X	X	X
Sensor - Black plastic case with LCD display, rated for plenum mounting		87N52	X	X	X	X
Sensor - Wall-mount, black plastic case, no display, rated for plenum mounting		87N54	X	X	X	X
CO ₂ Sensor Duct Mounting Kit - for downflow applications		85L43	X	X	X	X
Aspiration Box - for duct mounting non-plenum rated CO ₂ sensors (77N39 or 87N53)		90N43	X	X	X	X
Needlepoint Bipolar Ionization (NPBI)						
Needlepoint Bipolar Ionization (NPBI) Kit		22U14	X	X	X	X
UVC Germicidal Lamps						
¹ Healthy Climate® UVC Light Kit (110/230V-1ph)		21A92	X	X	X	X
Step-Down Transformers	460V primary, 230V secondary	10H20		X	X	X
	575V primary, 230V secondary	10H21		X	X	X
ROOF CURBS						
Hybrid Roof Curbs, Downflow						
8 in. height		11F50	X	X	X	X
14 in. height		11F51	X	X	X	X
18 in. height		11F52	X	X	X	X
24 in. height		11F53	X	X	X	X
Adjustable Pitched Curb						
14 in. height		43W27	X	X	X	X
Transition Curb						
Matches Enlight™ 024-060 Units to existing L Series® Curbs		31B05	X	X	X	X
CEILING DIFFUSERS						
Step-Down - Order one	RTD11-95S	13K61	X	X	X	X
Flush - Order one	FD11-95S	13K56	X	X	X	X
Transitions (Supply and Return) - Order one	T1TRAN20N-1	17W54	X	X	X	X

¹ Lamps operate on 110-230V single-phase power supply. Step-down transformer may be ordered separately for 460V and 575V units. Alternately, 110V power supply may be used to directly power the UVC ballast(s).

NOTE - Catalog numbers shown are for ordering field installed accessories.

OX - Configure To Order (Factory Installed) or Field Installed

O = Configure To Order (Factory Installed)

X = Field Installed

SPECIFICATIONS		UNIT				
General Data		2 Ton	3 Ton	4 Ton	5 Ton	
Nominal Tonnage						
Model Number		LDT024H4E	LDT036H4E	LDT048H4E	LDT060H4E	
Efficiency Type		High	High	High	High	
Blower Type		MSAV® ECM Direct Drive	MSAV® ECM Direct Drive	MSAV® ECM Direct Drive	MSAV® ECM Direct Drive	
Cooling Performance	Gross Cooling Capacity (Btuh)	25,000	37,000	46,800	58,000	
	¹ Net Cooling Capacity (Btuh) 3ph	---	35,000	44,500	55,000	
	¹ AHRI Rated Air Flow (cfm-high/low) 3ph	---	1400/935	1400/1100	1800/1300	
	¹ SEER (Btuh/Watt) 3ph	---	16.1	16.1	16.1	
	¹ EER (Btuh/Watt) 3ph	---	12.3	12.8	12.2	
	Total Unit Power (kW) 3ph	---	2.8	3.5	4.5	
	¹ Net Cooling Capacity (Btuh) 1ph	23,600	35,000	44,500	55,000	
	¹ AHRI Rated Air Flow (cfm-high/low) 1ph	1050	1400/935	1400/1100	1800/1300	
	¹ SEER2 (Btuh/Watt) 1ph	15.4	15.2	15.6	15.2	
	¹ EER2 (Btuh/Watt) 1ph	11.4	11.4	12.0	11.4	
	Total Unit Power (kW) 1ph	2.1	3.1	3.7	4.8	
	Heating Performance	¹ Total High Heating Capacity - Btuh	23,000	35,000	44,000	55,000
		¹ AHRI Rated Air Flow (cfm) 3ph	1050	1400	1400	1900
		¹ HSPF (Region IV) - 3ph	---	8.5	8.5	8.5
COP		---	3.8	3.9	3.7	
Total Unit Power (kW)		1.9	2.9	3.6	4.3	
¹ HSPF2 (Region IV) - 1ph		7.3	7.2	7.2	7.2	
¹ Total Low Heating Capacity - Btuh		17,000	19,000	26,000	30,000	
COP		---	2.3	2.4	2.3	
Total Unit Power (kW)		2.4	2.6	3.3	3.8	
² Sound Rating Number (SRN) (dBA)		75	75	82	82	
Refrigerant	Type	R-410A	R-410A	R-410A	R-410A	
	Charge Furnished	17 lbs. 14 oz.	18 lbs. 12 oz.	14 lbs. 0 oz.	17 lbs. 1 oz.	
Gas Heating Options Available		See page 5				
Compressor Type (one per unit)		Two-Stage Scroll	Two-Stage Scroll	Two-Stage Scroll	Two-Stage Scroll	
Outdoor Coil	Net face area (total) - sq. ft.	19.3	19.3	19.3	19.3	
	Tube diameter - in.	3/8	3/8	3/8	3/8	
	Number of rows	2	2	2	3	
	Fins per inch	20	20	20	20	
Outdoor Coil Fans	Motor - (No.) horsepower	(1) 1/3 (ECM)	(1) 1/3 (ECM)	(1) 1/3 (ECM)	(1) 1/3 (ECM)	
	Motor rpm	730	850/575	850/700	945/725	
	Total Motor watts	130	70 - 240	140 - 240	140 - 310	
	Diameter - (No.) in. and no. of blades	(1) 24	(1) 24	(1) 24	(1) 24	
	Total air volume - cfm	3500	4060/2740	4060/3330	4400/3550	
Indoor Coil	Net face area (total) - sq. ft.	9.7	9.7	9.7	9.7	
	Tube diameter - in.	3/8	3/8	3/8	3/8	
	Number of rows	3	3	3	4	
	Fins per inch	14	14	14	14	
	Drain connection (Number) and size - in.	(1) 1 NPT	(1) 1 NPT	(1) 1 NPT	(1) 1 NPT	
	Expansion device type	Balanced Port Thermostatic Expansion Valve,removable element head				
Indoor Blower	Standard	Blower Type Direct Drive ECM				
	Static	Blade type Forward Curved				
	(All Voltages)	Nominal motor HP	0.50	0.50	1	1
		Blower wheel D x W - in.	(1) 10 X 10	(1) 10 X 10	(1) 11 X 10	(1) 11 X 10
	High	Blower Type DirectPlus™ Direct Drive ECM				
	Static	Blade type Backward Curved				
	(3ph Only)	Nominal motor HP	---	1.5	1.5	1.5
	Blower wheel D x W - in.	---	(1) 14 X 5	(1) 14 X 5	(1) 14 X 5	
Filters	Type of filter	MERV 4, Disposable				
	Number and size	(4) 20 x 20 x 2				
Electrical characteristics		208/230V - 60 Hz - 1 phase	208/230V - 60 Hz - 1 phase 208/230V, 460V, or 575V - 60 Hz - 3 phase			

NOTE - Net capacity includes evaporator blower motor heat deduction. Gross capacity does not include evaporator blower motor heat deduction.

¹ AHRI Certified to AHRI Standard 210/240 (2-5 ton):

Cooling Ratings - 95°F outdoor air temperature and 80°F db/67°F wb entering indoor coil air.

High Temperature Heating Ratings - 47°F db/43°F wb outdoor air temperature and 70°F entering indoor coil air.

Low Temperature Heating Ratings - 17°F db/15°F wb outdoor air temperature and 70°F entering indoor coil air.

SPECIFICATIONS

LOW NOX GAS HEAT

Model No.		024, 036, 048, 060	036, 048, 060	024, 036, 048, 060	048, 060
Heat Input Type		Standard (2 Stage)		Medium (2 Stage)	High (2 Stage)
Input Btuh	1st Stage	53,000		81,000	113,000
	2nd Stage	65,000		108,000	150,000
Output Btuh	1st Stage	43,000		66,000	92,000
	2nd Stage	52,000		87,000	121,000
Temperature Rise Range - °F	1st stage	5-35		25 - 55	30 - 60
	2nd Stage	35-65 (0.5 and 1 hp)	15-45 (1.5 hp)	30 - 70	45 - 75
Minimum air volume - cfm		1075	1075	1150	1500
¹ AFUE (Single Phase)		81%		81%	81%
² Thermal Efficiency (Three Phase)		81%		81%	81%
Gas Supply Connections		1/2 in. NPT			
Recommended Gas Supply Pressure - Nat. / LPG		7 in. w.g. / 11 in. w.g.			
Gas Supply Pressure Range	Min./Max. (Natural)	4.5 - 10.5 in. w.g.			
	Min./Max. (LPG)	10.8 - 13.5 in. w.g.			

¹ Annual Fuel Utilization Efficiency based on U.S. DOE test procedures and FTC labeling regulations.

² Thermal Efficiency at full input.

HIGH ALTITUDE DERATE

NOTE - Units may be installed at altitudes up to 2000 ft. above sea level without any modifications. At altitudes above 2000 ft. units must be derated to match information in the table shown. At altitudes above 4500 ft. unit must be derated 2% for each 1000 ft. above sea level.
NOTE - This is the only permissible derate for these units.

Heat Input Type	Altitude Feet	Gas Manifold Pressure in. w.g.		Input Rate (Btuh)
		Natural Gas	LPG/ Propane	
Standard (2 stage)	2001 - 4500	3.0/1.7	9.0/5.1	60,000 / 49,000
Medium (2 stage)	2001 - 4500	3.0/1.7	9.0/5.1	100,000 / 75,000
High (2 stage)	2001 - 4500	3.0/1.7	9.0/5.1	139,000 / 104,000

BLOWER DATA

0.5 HP | 3 ROW (024, 036)

BLOWER TABLE INCLUDES RESISTANCE FOR BASE UNIT ONLY WITH DRY INDOOR COIL AND AIR FILTERS IN PLACE.

FOR ALL UNITS ADD:

- 1 - Any factory installed options air resistance (heat section, economizer, etc.).
- 2 - Any field installed accessories air resistance (duct resistance, diffuser, etc.).

Minimum Air Volume Required For Different Gas Heat Sizes:

Standard Heat - 1075 cfm; Medium Heat - 1150 cfm; High Heat - 1500 cfm

See page 14 for wet coil and options/accessory air resistance data.

DOWNFLOW

External Static Press. in. w.g.	Percentage of Total Motor Torque																										
	20%			30%			40%			50%			60%			70%			80%			90%			100%		
	Cfm	Watts	RPM	Cfm	Watts	RPM	Cfm	Watts	RPM	Cfm	Watts	RPM	Cfm	Watts	RPM	Cfm	Watts	RPM	Cfm	Watts	RPM	Cfm	Watts	RPM	Cfm	Watts	RPM
0	819	47	403	1006	79	463	1192	111	523	1335	152	573	1477	193	622	1580	236	661	1682	279	699	1812	353	753	1876	400	783
0.1	723	48	485	919	82	539	1114	116	593	1264	159	637	1414	202	681	1522	246	715	1629	290	749	1767	365	797	1835	414	824
0.2	636	51	565	840	88	613	1044	124	660	1201	169	699	1357	213	738	1470	258	769	1582	303	799	1726	380	841	1797	429	865
0.3	557	57	641	769	96	683	981	134	725	1144	180	760	1306	226	794	1423	273	821	1540	319	848	1689	397	885	1761	446	906
0.4	485	65	713	704	106	750	923	146	787	1091	194	818	1259	241	848	1380	289	872	1500	336	895	1653	415	929	1725	463	948
0.5	418	73	783	644	116	815	870	158	846	1043	207	873	1215	256	900	1339	305	921	1462	353	942	1618	433	973	1689	481	991
0.6	355	82	849	587	127	876	819	171	903	996	222	927	1173	272	950	1299	321	969	1425	370	987	1582	451	1016	1651	499	1034
0.7	---	---	---	---	---	---	769	184	957	950	236	978	1131	287	998	1259	337	1015	1387	387	1032	1544	468	1058	1610	516	1077
0.8	---	---	---	---	---	---	720	195	1008	904	248	1026	1088	301	1044	1218	352	1060	1347	403	1075	1503	484	1101	1565	531	1121
0.9	---	---	---	---	---	---	670	206	1057	857	260	1073	1043	314	1088	1173	366	1102	1303	417	1116	1458	498	1142	---	---	---
1.0	---	---	---	---	---	---	617	214	1102	806	269	1116	994	324	1130	1125	376	1144	1255	428	1157	1406	510	1184	---	---	---
1.1	---	---	---	---	---	---	561	219	1145	751	276	1157	941	332	1169	1071	384	1183	1200	436	1196	1347	518	1225	---	---	---
1.2	---	---	---	---	---	---	500	221	1185	691	278	1196	881	335	1207	1010	388	1221	1139	441	1234	1280	522	1265	---	---	---
1.3	---	---	---	---	---	---	---	---	---	---	---	---	814	335	1242	942	388	1256	1069	441	1270	---	---	---	---	---	---
1.4	---	---	---	---	---	---	---	---	---	---	---	---	738	330	1276	864	384	1291	989	437	1305	---	---	---	---	---	---

HORIZONTAL

External Static Press. in. w.g.	Percentage of Total Motor Torque																										
	20%			30%			40%			50%			60%			70%			80%			90%			100%		
	Cfm	Watts	RPM	Cfm	Watts	RPM	Cfm	Watts	RPM	Cfm	Watts	RPM	Cfm	Watts	RPM	Cfm	Watts	RPM	Cfm	Watts	RPM	Cfm	Watts	RPM	Cfm	Watts	RPM
0	794	45	388	970	76	454	1146	107	519	1281	149	575	1416	191	630	1522	110	678	1627	293	726	1715	351	768	1802	408	810
0.1	709	44	460	895	78	519	1080	111	577	1223	155	627	1366	199	677	1477	251	721	1588	303	764	1681	362	804	1773	420	843
0.2	630	46	531	855	82	583	1019	117	634	1169	163	679	1318	208	723	1435	262	763	1552	315	803	1648	375	841	1743	434	878
0.3	556	51	602	759	88	646	961	125	690	1117	172	730	1273	219	769	1395	274	805	1516	328	841	1615	388	877	1714	448	912
0.4	486	58	671	696	97	709	906	135	746	1068	184	781	1230	232	815	1356	288	848	1481	343	880	1582	403	914	1683	463	948
0.5	420	66	740	637	107	771	854	147	802	1021	196	831	1188	245	860	1317	301	890	1446	357	919	1549	418	951	1652	478	983
0.6	---	---	---	---	---	---	804	159	856	946	209	881	1147	259	905	1279	316	932	1410	372	958	1514	432	989	1618	492	1019
0.7	---	---	---	---	---	---	756	172	910	932	223	930	1107	273	949	1241	330	973	1374	386	996	1478	446	1026	1582	506	1055
0.8	---	---	---	---	---	---	709	185	962	888	236	978	1066	287	993	1201	344	1014	1336	400	1034	1440	460	1063	1544	519	1091
0.9	---	---	---	---	---	---	663	197	1013	844	249	1025	1025	300	1036	1161	357	1054	1296	413	1072	1399	472	1100	1502	530	1127
1.0	---	---	---	---	---	---	---	---	---	---	---	---	982	313	1078	1118	369	1094	1254	424	1109	1355	482	1136	1456	540	1163
1.1	---	---	---	---	---	---	---	---	---	---	---	---	938	323	1119	1073	379	1133	1208	434	1146	1307	491	1172	1406	548	1198
1.2	---	---	---	---	---	---	---	---	---	---	---	---	892	332	1158	1026	387	1170	1159	441	1182	1255	497	1208	1351	553	1233
1.3	---	---	---	---	---	---	---	---	---	---	---	---	843	340	1197	975	393	1207	1106	446	1216	1198	501	1242	1290	555	1268
1.4	---	---	---	---	---	---	---	---	---	---	---	---	790	344	1234	920	396	1242	1049	448	1250	1137	501	1276	1224	553	1302

BLOWER DATA

1.0 HP | 3 ROW (048)

BLOWER TABLE INCLUDES RESISTANCE FOR BASE UNIT ONLY WITH DRY INDOOR COIL AND AIR FILTERS IN PLACE.

FOR ALL UNITS ADD:

1 - Any factory installed options air resistance (heat section, economizer, etc.).

2 - Any field installed accessories air resistance (duct resistance, diffuser, etc.).

Minimum Air Volume Required For Different Gas Heat Sizes:

Standard Heat - 1075 cfm; Medium Heat - 1150 cfm; High Heat - 1500 cfm

See page 14 for wet coil and options/accessory air resistance data.

DOWNFLOW

External Static Press. in. w.g.	Percentage of Total Motor Torque																										
	20%		30%		40%		50%		60%		70%		80%		90%		100%										
	Cfm	RPM	Cfm	RPM	Cfm	RPM	Cfm	RPM	Cfm	RPM	Cfm	RPM	Cfm	RPM	Cfm	RPM	Cfm	RPM	Cfm	RPM	Cfm	RPM					
0	1115	124	488	1344	200	572	1573	276	655	1747	377	724	1920	477	792	2041	581	844	2161	684	896	2304	852	964	2354	936	992
0.1	1012	101	536	1253	181	614	1493	261	691	1677	366	755	1860	471	819	1990	578	868	2119	685	916	2277	860	980	2339	951	1006
0.2	926	88	584	1177	172	656	1427	256	728	1619	365	788	1811	473	848	1949	583	894	2086	693	939	2256	873	999	2328	969	1024
0.3	854	86	634	1113	173	701	1372	260	767	1572	371	823	1772	482	878	1916	595	921	2059	707	963	2240	891	1019	2319	991	1043
0.4	794	91	684	1061	181	746	1328	270	807	1535	383	859	1741	496	910	1890	611	950	2038	725	989	2226	913	1042	2311	1014	1065
0.5	745	104	734	1019	195	791	1292	286	847	1504	401	895	1715	515	942	1868	631	979	2020	747	1016	2214	936	1066	2301	1039	1089
0.6	704	122	785	983	215	837	1262	307	888	1478	423	932	1693	538	976	1849	654	1011	2004	770	1045	2201	960	1092	2288	1063	1114
0.7	671	145	836	954	238	883	1237	331	929	1456	447	969	1674	562	1009	1831	678	1041	1988	794	1073	2185	983	1118	2270	1085	1140
0.8	643	171	886	929	264	928	1215	357	969	1435	472	1006	1655	587	1043	1813	703	1073	1970	818	1103	2164	1005	1145	2246	1104	1168
0.9	619	199	935	907	291	973	1194	383	1010	1415	498	1043	1635	612	1076	1792	726	1104	1948	840	1132	2138	1024	1173	2212	1119	1196
1.0	596	228	983	884	319	1016	1172	410	1049	1392	523	1079	1612	635	1109	1766	747	1135	1920	859	1161	2104	1038	1200	---	---	---
1.1	---	---	---	---	---	---	1148	434	1087	1366	545	1115	1583	655	1142	1734	765	1166	1885	874	1189	2060	1047	1227	---	---	---
1.2	---	---	---	---	---	---	1120	456	1124	1334	564	1149	1548	671	1173	1695	777	1195	1841	883	1217	2004	1050	1254	---	---	---
1.3	---	---	---	---	---	---	1085	474	1159	1295	578	1181	1505	681	1202	1646	784	1223	1786	886	1244	1935	1044	1280	---	---	---
1.4	---	---	---	---	---	---	1043	486	1192	1247	586	1211	1451	685	1230	1585	783	1250	1718	881	1269	1851	1029	1305	---	---	---

HORIZONTAL

External Static Press. in. w.g.	Percentage of Total Motor Torque																										
	20%		30%		40%		50%		60%		70%		80%		90%		100%										
	Cfm	RPM	Cfm	RPM	Cfm	RPM	Cfm	RPM	Cfm	RPM	Cfm	RPM	Cfm	RPM	Cfm	RPM	Cfm	RPM	Cfm	RPM	Cfm	RPM	Cfm	RPM	Cfm	RPM	Cfm
0	1087	111	493	1304	184	579	1520	257	665	1689	368	738	1857	478	810	1972	588	864	2087	698	918	2196	844	975	2283	925	1000
0.1	1021	104	537	1246	180	618	1470	255	699	1646	368	768	1821	480	837	1941	592	888	2061	704	938	2179	852	992	2255	926	1017
0.2	961	102	582	1193	181	658	1425	259	734	1607	373	799	1789	487	864	1914	601	912	2039	714	960	2163	864	1012	2231	932	1034
0.3	906	106	628	1145	186	699	1384	266	769	1572	382	831	1759	498	892	1889	613	938	2018	728	984	2149	879	1033	2209	941	1053
0.4	855	113	674	1101	196	740	1347	278	806	1540	396	864	1732	513	921	1866	629	965	1999	744	1008	2134	896	1054	---	---	---
0.5	808	125	720	1060	209	781	1312	293	842	1509	412	896	1706	530	950	1843	646	992	1980	762	1033	2119	915	1077	---	---	---
0.6	764	139	766	1022	225	823	1279	310	879	1481	430	930	1682	549	980	1821	666	1019	1960	782	1058	2102	935	1101	---	---	---
0.7	722	155	812	985	242	864	1247	328	916	1452	449	964	1657	569	1011	1799	686	1048	1940	803	1084	2084	955	1125	---	---	---
0.8	682	172	858	949	260	906	1216	348	953	1424	469	997	1632	589	1041	1776	706	1076	1919	823	1111	2063	974	1150	---	---	---
0.9	643	191	903	914	279	946	1185	367	989	1396	489	1030	1606	610	1071	1751	727	1104	1895	843	1137	2039	992	1175	---	---	---
1.0	---	---	---	---	---	---	1153	386	1024	1366	508	1062	1579	629	1100	1724	745	1132	1869	861	1163	2011	1008	1201	---	---	---
1.1	---	---	---	---	---	---	1120	404	1059	1334	525	1095	1548	646	1130	1694	761	1160	1839	876	1189	1979	1021	1226	---	---	---
1.2	---	---	---	---	---	---	1085	420	1093	1300	541	1126	1515	661	1158	1660	775	1186	1805	889	1214	1941	1031	1250	---	---	---
1.3	---	---	---	---	---	---	1047	433	1126	1263	553	1156	1478	672	1186	1622	785	1213	1766	898	1239	1897	1037	1275	---	---	---
1.4	---	---	---	---	---	---	1005	442	1158	1221	561	1185	1436	680	1212	1579	792	1238	1721	903	1263	1847	1037	1298	---	---	---

BLOWER DATA

1.0 HP | 4 ROW (060)

BLOWER TABLE INCLUDES RESISTANCE FOR BASE UNIT ONLY WITH DRY INDOOR COIL AND AIR FILTERS IN PLACE.

FOR ALL UNITS ADD:

1 - Any factory installed options air resistance (heat section, economizer, etc.).

2 - Any field installed accessories air resistance (duct resistance, diffuser, etc.).

Minimum Air Volume Required For Different Gas Heat Sizes:

Standard Heat - 1075 cfm; Medium Heat - 1150 cfm; High Heat - 1500 cfm

See page 14 for wet coil and options/accessory air resistance data.

DOWNFLOW

External Static Press. in. w.g.	Percentage of Total Motor Torque																										
	20%		30%		40%		50%		60%		70%		80%		90%		100%										
	Cfm	RPM	Cfm	RPM	Cfm	RPM	Cfm	RPM	Cfm	RPM	Cfm	RPM	Cfm	RPM	Cfm	RPM	Cfm	RPM	Cfm	RPM							
0	1101	120	494	1328	196	578	1555	272	662	1728	374	731	1901	475	800	852	2145	684	903	2292	854	970	2348	942	998		
0.1	1002	99	541	1241	180	620	1479	260	698	1662	366	763	1845	471	827	1976	579	876	2106	687	924	2268	865	987	2334	958	1013
0.2	918	88	589	1167	173	663	1416	257	736	1608	366	796	1800	475	856	1938	586	902	2076	697	947	2249	880	1006	2324	978	1031
0.3	848	86	638	1106	174	706	1364	261	774	1564	373	830	1763	485	886	1907	599	929	2051	712	972	2234	899	1028	2316	1000	1052
0.4	790	92	688	1056	183	751	1321	273	814	1527	387	866	1733	501	918	1882	617	958	2031	732	998	2221	921	1051	2307	1024	1074
0.5	742	105	738	1015	197	796	1287	289	854	1498	405	902	1709	520	950	1862	637	988	2014	754	1025	2208	944	1076	2296	1048	1099
0.6	703	124	788	981	217	841	1258	310	894	1473	427	939	1688	543	984	1843	660	1019	1998	777	1053	2194	968	1101	2281	1071	1124
0.7	670	146	838	952	240	887	1233	334	935	1451	451	976	1669	568	1017	1826	685	1050	1982	801	1082	2177	991	1128	2260	1092	1151
0.8	642	172	888	927	266	932	1211	360	975	1431	477	1013	1650	593	1051	1807	709	1081	1963	825	1111	2155	1012	1155	2233	1109	1178
0.9	618	200	937	904	294	976	1190	387	1015	1410	502	1050	1629	617	1084	1785	732	1112	1940	846	1140	2127	1029	1182	2209	1182	1233
1.0	595	229	985	882	321	1020	1168	413	1054	1387	526	1086	1605	639	1117	1758	752	1143	1911	864	1169	2090	1042	1209	2182	1233	1288
1.1	571	257	1034	859	349	1068	1137	437	1092	1360	548	1120	1576	659	1148	1725	769	1173	1874	878	1197	2043	1049	1236	2162	1233	1342
1.2	548	285	1084	836	377	1115	1115	458	1129	1328	566	1154	1540	674	1179	1685	780	1202	1829	886	1225	1985	1049	1262	2132	1233	1401
1.3	525	313	1131	815	405	1163	1080	475	1163	1288	579	1186	1496	683	1208	1634	785	1230	1772	887	1251	1913	1042	1288	2102	1233	1460
1.4	502	341	1178	794	433	1196	1037	487	1196	1239	587	1216	1441	686	1236	1572	783	1256	1703	880	1275	1826	1024	1312	2072	1233	1519

HORIZONTAL

External Static Press. in. w.g.	Percentage of Total Motor Torque																										
	20%		30%		40%		50%		60%		70%		80%		90%		100%										
	Cfm	RPM	Cfm	RPM	Cfm	RPM	Cfm	RPM	Cfm	RPM	Cfm	RPM	Cfm	RPM	Cfm	RPM	Cfm	RPM	Cfm	RPM	Cfm	RPM	Cfm	RPM	Cfm	RPM	
0	1077	113	502	1282	175	585	1486	237	668	1670	363	746	1854	489	823	1993	623	884	2131	757	944	2216	882	995	2268	926	1009
0.1	1016	109	546	1227	172	624	1437	234	701	1626	361	775	1814	488	848	1956	623	906	2098	757	964	2194	887	1011	2242	928	1026
0.2	962	111	591	1177	174	663	1392	236	735	1585	364	805	1777	492	874	1923	627	930	2069	762	985	2175	895	1029	2218	935	1044
0.3	913	118	636	1133	181	703	1352	244	770	1548	372	836	1744	500	902	1893	636	955	2042	772	1007	2157	907	1048	2196	945	1063
0.4	868	130	682	1092	193	744	1315	256	806	1515	384	868	1714	512	930	1866	648	980	2018	784	1030	2139	922	1069	2169	945	1063
0.5	827	146	728	1054	209	785	1281	271	842	1484	399	901	1687	526	959	1841	663	1007	1995	799	1054	2121	938	1090	2149	945	1063
0.6	789	165	775	1019	227	827	1249	288	879	1455	416	934	1660	543	988	1816	679	1034	1972	815	1079	2102	955	1113	2129	945	1063
0.7	752	185	821	986	247	869	1219	308	916	1427	435	967	1634	562	1018	1792	698	1061	1949	833	1104	2081	972	1136	2102	945	1063
0.8	718	208	867	954	268	910	1189	328	953	1399	455	1000	1608	581	1047	1767	716	1088	1925	851	1129	2058	989	1160	2072	945	1063
0.9	684	231	913	922	290	951	1160	349	989	1371	475	1033	1581	600	1077	1741	734	1116	1900	868	1154	2031	1004	1185	2042	945	1063
1.0	651	259	960	897	318	1000	1129	369	1025	1341	494	1066	1553	618	1106	1713	751	1143	1872	884	1179	2001	1017	1209	2012	945	1063
1.1	618	287	1007	874	346	1048	1097	388	1060	1310	511	1098	1522	634	1135	1682	766	1170	1841	898	1204	1966	1028	1233	2002	945	1063
1.2	585	315	1054	859	374	1096	1063	405	1095	1276	527	1129	1488	648	1163	1647	779	1196	1806	909	1228	1925	1034	1257	2002	945	1063
1.3	552	343	1101	840	402	1145	1026	420	1128	1239	540	1159	1451	659	1190	1609	788	1221	1767	917	1252	1879	1036	1281	2002	945	1063
1.4	519	371	1148	821	430	1194	985	431	1160	1197	548	1188	1409	665	1216	1566	793	1245	1723	920	1274	1825	1033	1304	2002	945	1063

1.5 HP | 3 ROW (036, 048)

BLOWER DATA
BLOWER TABLE INCLUDES RESISTANCE FOR BASE UNIT ONLY WITH DRY INDOOR COIL AND AIR FILTERS IN PLACE.

FOR ALL UNITS ADD:
 1 - Any factory installed options air resistance (heat section, economizer, etc.).
 2 - Any field installed accessories air resistance (duct resistance, diffuser, etc.).

Minimum Air Volume Required For Different Gas Heat Sizes:
 Standard Heat - 1075 cfm; Medium Heat - 1150 cfm; High Heat - 1500 cfm

See page 14 for wet coil and options/accessory air resistance data.

DOWNFLOW

Total Air cfm	Total Static Pressure - in. w.g.																										
	0.1		0.2		0.3		0.4		0.5		0.6		0.7		0.8		0.9		1.0		1.1		1.2		1.3		
	RPM	Watts	RPM	Watts	RPM	Watts	RPM	Watts	RPM	Watts	RPM	Watts	RPM	Watts	RPM	Watts	RPM	Watts	RPM	Watts	RPM	Watts	RPM	Watts	RPM	Watts	RPM
400	718	19	803	41	878	60	1080	92	1149	127	1226	129	1307	126	1386	124	1574	197	1630	220	1681	250	1731	279	1779	307	
600	845	50	929	72	1008	92	1080	111	1149	127	1226	129	1307	126	1386	124	1574	197	1630	220	1681	250	1731	279	1779	307	
800	971	79	1057	101	1138	123	1214	143	1286	160	1362	168	1439	173	1510	181	1697	263	1747	293	1796	324	1844	353	1890	379	
1000	1136	113	1215	135	1293	157	1367	177	1438	196	1510	209	1579	222	1642	239	1834	332	1878	368	1923	400	1970	428	2015	454	
1200	1335	151	1406	172	1476	193	1544	213	1611	232	1675	250	1735	272	1788	299	1978	405	2019	439	2063	469	2108	496	2152	522	
1400	1560	177	1617	204	1675	231	1732	257	1788	283	1841	310	1891	339	1936	371	2080	461	2169	513	2213	541	2256	570	2297	601	
1600	1742	245	1792	278	1842	311	1892	344	1940	376	1988	406	2035	434	2080	461	2244	539	2287	568	2328	600	2369	634	2408	708	
1800	1922	330	1970	363	2017	395	2064	426	2110	457	2155	485	2200	512	2244	539	2413	640	2452	681	2490	723	2527	766	2564	851	
2000	2112	405	2158	438	2202	471	2246	503	2289	536	2331	568	2373	602	2413	640	2582	784	2619	832	2654	878	2690	923	2724	1007	
2200	2305	493	2347	531	2389	569	2429	608	2469	648	2508	691	2546	737	2582	784	2757	939	2791	986	2825	1031	2858	1075	2891	1158	
2400	2499	617	2539	660	2578	704	2615	748	2652	794	2688	841	2722	890	2757	939	2936	1099	2968	1143	3000	1186	3031	1228	3062	1311	
2600	2697	773	2733	818	2769	864	2803	911	2837	957	2871	1005	2903	1052	2936	1099	3118	1259	3147	1300	3177	1341	3206	1382	1423	1463	
2800	2896	944	2929	990	2962	1036	2993	1082	3025	1128	3056	1173	3087	1216	3118	1259	3300	1416	3327	1456	3355	1495	3383	1536	1576	1615	
3000	3093	1115	3124	1160	3154	1205	3184	1249	3214	1293	3243	1335	3272	1376	3300	1416	3327	1456	3355	1495	3383	1536	3410	1576	1615	1615	

Total Static Pressure - in. w.g.

Total Air cfm	Total Static Pressure - in. w.g.													
	1.4		1.5		1.6		1.7		1.8		1.9		2.0	
	RPM	Watts	RPM	Watts	RPM	Watts	RPM	Watts	RPM	Watts	RPM	Watts	RPM	Watts
800	1826	333	---	---	---	---	---	---	---	---	---	---	---	
1000	1935	403	1979	424	2021	444	2064	464	2106	485	2149	509	2191	533
1200	2058	476	2100	498	2142	518	2184	541	2226	565	2267	592	2308	619
1400	2194	548	2235	574	2275	601	2316	629	2356	658	2395	689	2433	720
1600	2337	632	2377	665	2415	698	2453	733	2490	768	2527	803	2563	839
1800	2484	746	2521	785	2557	824	2592	863	2627	902	2661	942	2695	981
2000	2634	894	2668	935	2701	977	2735	1018	2768	1058	2802	1099	2834	1139
2200	2790	1049	2823	1090	2855	1130	2887	1170	2919	1210	2952	1250	2984	1289
2400	2954	1200	2986	1240	3017	1280	3048	1320	3080	1360	3111	1399	3142	1437
2600	3123	1351	3153	1391	3184	1431	3215	1470	3245	1509	3276	1548	3306	1586
2800	3294	1502	3323	1542	3352	1580	3382	1619	3412	1658	3442	1696	3472	1734
3000	3464	1653	3492	1691	3520	1729	3549	1767	3578	1805	3608	1844	3638	1882

BLOWER DATA

1.5 HP | 3 ROW (036, 048)

BLOWER TABLE INCLUDES RESISTANCE FOR BASE UNIT ONLY WITH DRY INDOOR COIL AND AIR FILTERS IN PLACE.

FOR ALL UNITS ADD:

1 - Any factory installed options air resistance (heat section, economizer, etc.).

2 - Any field installed accessories air resistance (duct resistance, diffuser, etc.).

Minimum Air Volume Required For Different Gas Heat Sizes:

Standard Heat - 1075 cfm; Medium Heat - 1150 cfm; High Heat - 1500 cfm

See page 14 for wet coil and options/accessory air resistance data.

HORIZONTAL

Total Air cfm	Total Static Pressure - in. w.g.																										
	0.1		0.2		0.3		0.4		0.5		0.6		0.7		0.8		0.9		1.0		1.1		1.2		1.3		
	RPM	Watts	RPM	Watts	RPM	Watts	RPM	Watts	RPM	Watts	RPM	Watts	RPM	Watts	RPM	Watts	RPM	Watts	RPM	Watts	RPM	Watts	RPM	Watts	RPM	Watts	
400	708	16	793	37	872	53	957	71	1042	87	1221	103	1406	119	1585	135	1770	151	1955	167	2140	183	2325	199	2510	215	2695
600	835	46	918	65	1000	82	1077	95	1149	107	1221	109	1365	148	1434	154	1497	163	1555	179	1607	200	1656	226	1704	254	1752
800	981	75	1064	92	1144	109	1221	124	1294	139	1365	148	1434	154	1582	207	1638	227	1689	252	1737	279	1783	308	1829	335	1873
1000	1166	105	1241	124	1315	141	1387	159	1454	176	1520	191	1582	207	1739	271	1787	299	1832	330	1876	361	1920	391	1964	419	2007
1200	1374	142	1440	162	1506	182	1569	203	1630	224	1687	246	1739	271	1899	351	1942	382	1984	412	2026	442	2068	469	2110	496	2153
1400	1591	183	1647	209	1701	235	1755	263	1806	291	1854	320	1899	351	2059	444	2102	470	2144	494	2185	519	2227	545	2268	572	2309
1600	1778	258	1827	290	1876	323	1923	355	1970	386	2015	416	2059	444	2219	531	2279	557	2319	584	2359	613	2397	645	2435	679	2471
1800	1973	352	2018	383	2063	415	2107	445	2151	476	2194	504	2237	531	2385	596	2461	666	2496	705	2530	745	2564	786	2598	826	2631
2000	2182	437	2224	468	2265	499	2306	531	2346	563	2385	596	2424	630	2461	666	2496	705	2530	745	2564	786	2598	826	2631	866	2664
2200	2388	540	2426	576	2464	613	2500	651	2536	691	2571	731	2605	774	2637	819	2668	863	2698	907	2732	949	2764	990	2795	1029	2826
2400	2589	679	2624	719	2658	761	2691	803	2724	846	2756	890	2786	935	2816	980	2846	1025	2876	1068	2907	1109	2937	1149	2967	1188	3000
2600	2787	845	2819	887	2850	930	2881	973	2911	1017	2941	1060	2970	1104	2999	1147	3028	1189	3057	1230	3087	1270	3117	1310	3147	1350	3180
2800	2983	1021	3013	1063	3042	1106	3070	1149	3099	1191	3127	1230	3156	1270	3180	1310	3204	1350	3228	1390	3252	1430	3276	1470	3300	1510	3324

Total Static Pressure - in. w.g.

Total Air cfm	Total Static Pressure - in. w.g.													
	1.4		1.5		1.6		1.7		1.8		1.9		2.0	
	RPM	Watts	RPM	Watts	RPM	Watts	RPM	Watts	RPM	Watts	RPM	Watts	RPM	Watts
800	708	16	793	37	872	53	957	71	1042	87	1221	103	1406	
1000	835	46	918	65	1000	82	1077	95	1149	107	1221	109	1365	
1200	981	75	1064	92	1144	109	1221	124	1294	139	1365	148	1434	
1400	1166	105	1241	124	1315	141	1387	159	1454	176	1520	191	1582	
1600	1374	142	1440	162	1506	182	1569	203	1630	224	1687	246	1739	
1800	1591	183	1647	209	1701	235	1755	263	1806	291	1854	320	1899	
2000	1778	258	1827	290	1876	323	1923	355	1970	386	2015	416	2059	
2200	1973	352	2018	383	2063	415	2107	445	2151	476	2194	504	2237	
2400	2182	437	2224	468	2265	499	2306	531	2346	563	2385	596	2424	
2600	2388	540	2426	576	2464	613	2500	651	2536	691	2571	731	2605	
2800	2589	679	2624	719	2658	761	2691	803	2724	846	2756	890	2786	

BLOWER DATA **1.5 HP | 4 ROW (060)**

BLOWER TABLE INCLUDES RESISTANCE FOR BASE UNIT ONLY WITH DRY INDOOR COIL AND AIR FILTERS IN PLACE.

FOR ALL UNITS ADD:

- 1 - Any factory installed options air resistance (heat section, economizer, etc.).
- 2 - Any field installed accessories air resistance (duct resistance, diffuser, etc.).

Minimum Air Volume Required For Different Gas Heat Sizes:

Standard Heat - 1075 cfm; Medium Heat - 1150 cfm; High Heat - 1500 cfm

See page 14 for wet coil and options/accessory air resistance data.

DOWNFLOW

Total Air cfm	Total Static Pressure - in. w.g.																													
	0.1		0.2		0.3		0.4		0.5		0.6		0.7		0.8		0.9		1.0		1.1		1.2		1.3					
	RPM	Watts	RPM	Watts	RPM	Watts	RPM	Watts	RPM	Watts	RPM	Watts	RPM	Watts	RPM	Watts	RPM	Watts	RPM	Watts	RPM	Watts	RPM	Watts	RPM	Watts				
400	720	20	805	41	880	60	1033	73	1083	93	1145	103	1220	112	1229	128	1310	126	1389	125	1514	183	1578	198	1684	252	1734	281	1783	309
600	849	51	933	73	1011	93	1083	112	1152	128	1229	130	1367	170	1443	175	1586	224	1648	242	1795	302	1841	336	1930	405	1976	433	2021	458
800	978	81	1064	103	1145	124	1220	144	1291	162	1367	170	1443	179	1517	211	1586	224	1648	242	1795	302	1841	336	1930	405	1976	433	2021	458
1000	1147	116	1225	138	1302	159	1376	179	1446	198	1517	211	1586	224	1648	242	1795	302	1841	336	1930	405	1976	433	2021	458	1976	433	2021	458
1200	1347	154	1418	175	1487	196	1555	216	1620	235	1684	253	1743	275	1795	302	1841	336	1930	405	1976	433	2021	458	1976	433	2021	458	1976	433
1400	1571	182	1629	209	1696	236	1742	262	1798	288	1850	315	1899	346	1943	380	1984	417	2025	453	2068	485	2113	512	2156	537	2156	537	2156	537
1600	1753	252	1803	286	1853	318	1902	351	1951	383	1998	415	2043	447	2087	478	2130	508	2173	539	2216	568	2259	595	2302	621	2302	621	2302	621
1800	1935	339	1983	371	2030	403	2076	434	2122	465	2167	495	2210	524	2253	554	2295	586	2337	618	2378	650	2418	682	2458	714	2458	714	2458	714
2000	2127	415	2172	448	2217	481	2260	513	2303	546	2345	579	2385	614	2425	653	2464	693	2503	734	2541	774	2578	814	2614	855	2614	855	2614	855
2200	2321	507	2363	545	2404	583	2444	623	2484	664	2522	707	2560	753	2596	801	2632	848	2667	895	2703	939	2737	981	2770	1023	2770	1023	2770	1023
2400	2516	635	2556	679	2594	723	2631	767	2668	813	2703	861	2737	909	2772	958	2805	1005	2839	1050	2872	1093	2905	1135	2936	1176	2936	1176	2936	1176
2600	2715	796	2751	841	2786	887	2820	933	2854	980	2887	1027	2919	1074	2952	1120	2983	1164	3015	1207	3046	1249	3077	1290	3107	1330	3107	1330	3107	1330
2800	2915	970	2947	1016	2979	1062	3011	1107	3042	1152	3073	1197	3104	1240	3134	1282	3164	1323	3193	1364	3222	1404	3251	1445	3280	1485	3280	1485	3280	1485
3000	3112	1142	3142	1187	3172	1232	3202	1276	3232	1319	3261	1361	3289	1401	3317	1441	3344	1480	3371	1520	3399	1560	3426	1600	3453	1638	3453	1638	3453	1638

Total Static Pressure - in. w.g.

Total Air cfm	Total Static Pressure - in. w.g.													
	1.4		1.5		1.6		1.7		1.8		1.9		2.0	
	RPM	Watts	RPM	Watts	RPM	Watts	RPM	Watts	RPM	Watts	RPM	Watts	RPM	Watts
800	1830	335	---	---	---	---	---	---	---	---	---	---	---	
1000	1940	405	1983	426	2026	446	2068	466	2111	488	2154	512	2196	536
1200	2064	480	2106	501	2148	522	2190	544	2232	569	2273	595	2314	623
1400	2199	560	2241	584	2282	608	2323	634	2363	664	2402	694	2440	726
1600	2344	647	2384	675	2424	706	2462	740	2498	776	2535	811	2571	848
1800	2497	749	2533	788	2568	829	2602	872	2636	914	2671	953	2705	992
2000	2648	898	2681	941	2714	986	2746	1030	2779	1072	2812	1112	2845	1152
2200	2803	1064	2835	1105	2867	1145	2899	1186	2931	1225	2964	1265	2995	1303
2400	2968	1217	2999	1258	3031	1298	3062	1337	3093	1377	3124	1415	3156	1454
2600	3138	1371	3168	1411	3199	1450	3229	1489	3260	1528	3290	1566	3321	1604
2800	3309	1524	3338	1563	3368	1602	3398	1640	3428	1678	3458	1717	3488	1755
3000	3481	1677	3508	1715	3537	1752	3566	1790	3595	1828	3625	1866	3655	1904

BLOWER DATA

FACTORY INSTALLED OPTIONS/FIELD INSTALLED ACCESSORY AIR RESISTANCE - in. w.g.

Air Volume cfm	Wet Indoor Coil		Gas Heating		Economizer	Filters		
	024, 036, 048	060	Medium Heat	High Heat		MERV 8	MERV 13	MERV 16
800	0.01	---	0.02	0.02	0.04	0.04	0.05	0.04
1000	0.02	0.02	0.02	0.02	0.04	0.04	0.07	0.05
1200	0.03	0.04	0.02	0.02	0.04	0.04	0.07	0.05
1400	0.04	0.05	0.02	0.03	0.04	0.04	0.07	0.06
1600	0.05	0.07	0.03	0.04	0.04	0.04	0.07	0.08
1800	0.06	0.08	0.04	0.05	0.05	0.04	0.07	0.09
2000	0.08	0.10	0.04	0.06	0.05	0.05	0.08	0.10
2200	---	0.11	0.04	0.07	0.05	0.05	0.08	0.11
2400	---	0.13	0.05	0.08	0.05	0.05	0.08	0.12

POWER EXHAUST FAN PERFORMANCE

Return Air System Static Pressure in. w.g.	Air Volume Exhausted cfm
0.00	2000
0.05	1990
0.10	1924
0.15	1810
0.20	1664
0.25	1507
0.30	1350
0.35	1210

CEILING DIFFUSERS AIR RESISTANCE (in. w.g.)

Air Volume - cfm	RTD11-95S Step-Down Diffuser			FD11-95S Flush Diffuser
	2 Ends Open	1 Side & 2 Ends Open	All Ends & Sides Open	
1800	0.13	0.11	0.09	0.09
2000	0.15	0.13	0.11	0.10
2200	0.18	0.15	0.12	0.12
2400	0.21	0.18	0.15	0.14
2600	0.24	0.21	0.18	0.17
2800	0.27	0.24	0.21	0.20
3000	0.32	0.29	0.25	0.25

CEILING DIFFUSER AIR THROW DATA

Air Volume - cfm	¹ Effective Throw - ft.	
	RTD11-95S	FD11-95S
2600	24 - 29	19 - 24
2800	25 - 30	20 - 28
3000	27 - 33	21 - 29

¹ Effective throw based on terminal velocities of 75 ft. per minute.

ELECTRICAL DATA**2 TON**

Model No.		LDT024H4	
¹ Voltage - 60Hz		208/230V - 1 Ph	
Compressor	Rated Load Amps	15.3	
	Locked Rotor Amps	83	
Outdoor Fan Motor	Full Load Amps	2.8	
Power Exhaust (1) 0.33 HP	Full Load Amps	2.4	
Service Outlet 115V GFI (amps)		15	
Indoor Blower Motor	Horsepower	0.5	
	Full Load Amps	4.3	
² Maximum Overcurrent Protection	Unit Only	40	
	With (1) 0.33 HP Power Exhaust	40	
³ Minimum Circuit Ampacity	Unit Only	27	
	With (1) 0.33 HP Power Exhaust	29	

NOTE - All units have a minimum Short Circuit Current Rating (SCCR) of 5000 amps.

¹ Extremes of operating range are plus and minus 10% of line voltage.² HACR type breaker or fuse.³ Refer to National or Canadian Electrical Code manual to determine wire, fuse and disconnect size requirements.**ELECTRICAL DATA****3 TON**

Model No.		LDT036H4							
¹ Voltage - 60Hz		208/230V - 1 Ph		208/230V - 3 Ph		460V - 3 Ph		575V - 3 Ph	
Compressor	Rated Load Amps	15.3		11.6		5.7		4	
	Locked Rotor Amps	83		73		38		25.6	
Outdoor Fan Motor	Full Load Amps	2.8		2.8		1.4		1.1	
Power Exhaust (1) 0.33 HP	Full Load Amps	2.4		2.4		1.3		1	
Service Outlet 115V GFI (amps)		15		15		15		20	
Indoor Blower Motor	Horsepower	0.5		0.5	1.5	0.5	1.5	0.5	1.5
	Full Load Amps	4.3		4.3	4.4	2.2	2.3	1.7	2.3
² Maximum Overcurrent Protection	Unit Only	40		30	30	15	15	15	15
	With (1) 0.33 HP Power Exhaust	40		35	35	15	15	15	15
³ Minimum Circuit Ampacity	Unit Only	27		22	22	11	11	8	9
	With (1) 0.33 HP Power Exhaust	29		24	25	13	13	9	10

NOTE - All units have a minimum Short Circuit Current Rating (SCCR) of 5000 amps.

¹ Extremes of operating range are plus and minus 10% of line voltage.² HACR type breaker or fuse.³ Refer to National or Canadian Electrical Code manual to determine wire, fuse and disconnect size requirements.

ELECTRICAL DATA**4 TON**

Model No.		LDT048H4							
¹ Voltage - 60Hz		208/230V - 1 Ph	208/230V - 3 Ph		460V - 3 Ph		575V - 3 Ph		
Compressor	Rated Load Amps	21.2	14		6.4		4.6		
	Locked Rotor Amps	104	83.1		41		33		
Outdoor Fan Motor	Full Load Amps	2.8	2.8		1.4		1.1		
Power Exhaust (1) 0.33 HP	Full Load Amps	2.4	2.4		1.3		1		
Service Outlet 115V GFI (amps)		15	15		15		20		
Indoor Blower Motor	Horsepower	1	1	1.5	1	1.5	1	1.5	
	Full Load Amps	7.4	7.4	4.4	3.7	2.3	3	2.3	
² Maximum Overcurrent Protection	Unit Only	50	40	35	15	15	15	15	
	With (1) 0.33 HP Power Exhaust	60	40	40	20	15	15	15	
³ Minimum Circuit Ampacity	Unit Only	37	28	25	14	12	10	10	
	With (1) 0.33 HP Power Exhaust	40	31	28	15	14	11	11	

NOTE - All units have a minimum Short Circuit Current Rating (SCCR) of 5000 amps.

¹ Extremes of operating range are plus and minus 10% of line voltage.² HACR type breaker or fuse.³ Refer to National or Canadian Electrical Code manual to determine wire, fuse and disconnect size requirements.**ELECTRICAL DATA****5 TON**

Model No.		LDT060H4							
¹ Voltage - 60Hz		208/230V - 1 Ph	208/230V - 3 Ph		460V - 3 Ph		575V - 3 Ph		
Compressor	Rated Load Amps	27.1	16.5		7.2		5.5		
	Locked Rotor Amps	152.9	110		52		38.9		
Outdoor Fan Motor	Full Load Amps	2.8	2.8		1.4		1.1		
Power Exhaust (1) 0.33 HP	Full Load Amps	2.4	2.4		1.3		1		
Service Outlet 115V GFI (amps)		15	15		15		20		
Indoor Blower Motor	Horsepower	1	1	1.5	1	1.5	1	1.5	
	Full Load Amps	7.4	7.4	4.4	3.7	2.3	3	2.3	
² Maximum Overcurrent Protection	Unit Only	70	45	40	20	15	15	15	
	With (1) 0.33 HP Power Exhaust	70	45	45	20	20	15	15	
³ Minimum Circuit Ampacity	Unit Only	45	31	28	15	13	11	11	
	With (1) 0.33 HP Power Exhaust	47	34	31	16	15	12	12	

NOTE - All units have a minimum Short Circuit Current Rating (SCCR) of 5000 amps.

¹ Extremes of operating range are plus and minus 10% of line voltage.² HACR type breaker or fuse.³ Refer to National or Canadian Electrical Code manual to determine wire, fuse and disconnect size requirements.

LDT PARTS ARRANGEMENT

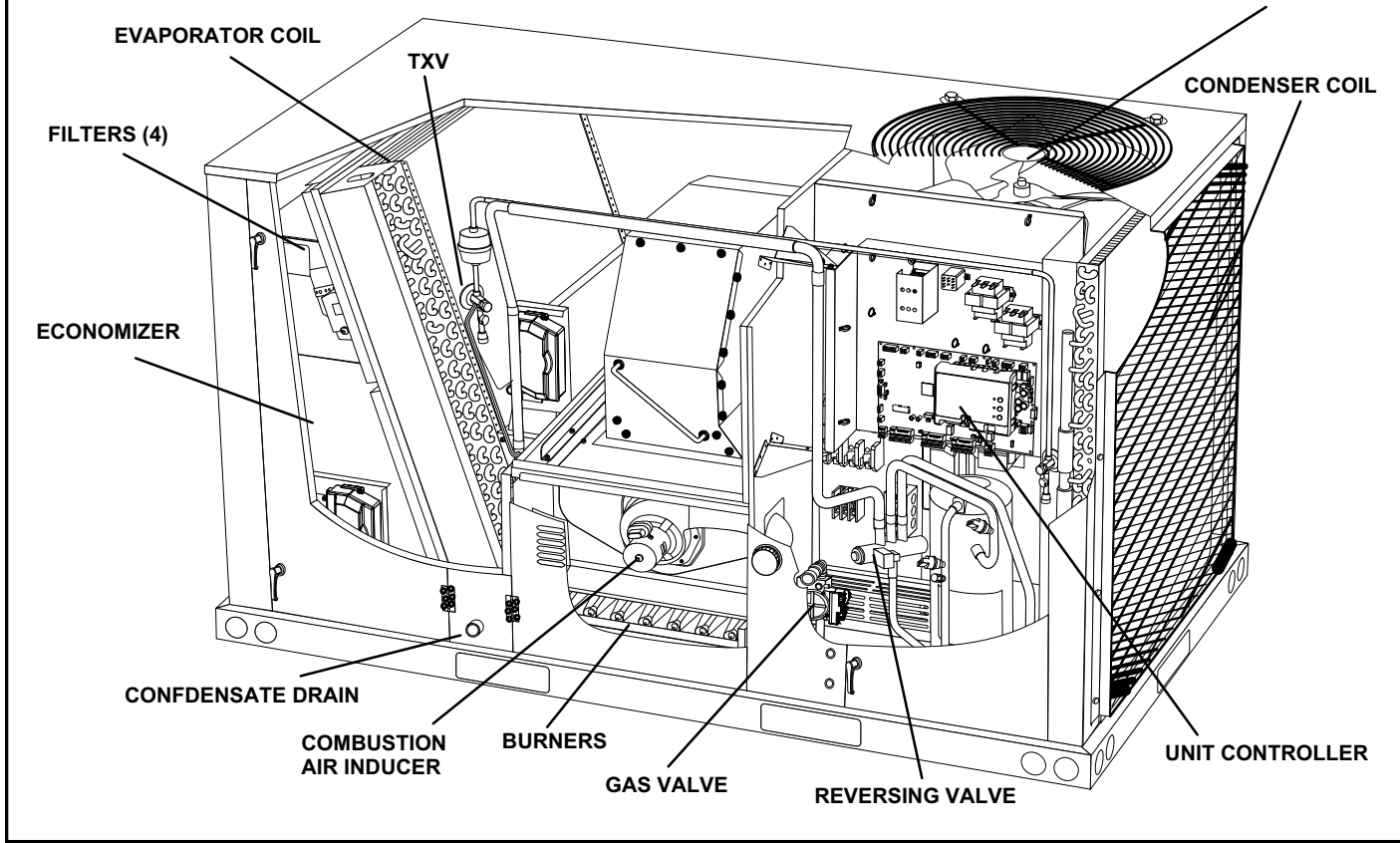

FIGURE 1

LDT HINGED CONTROL PANEL

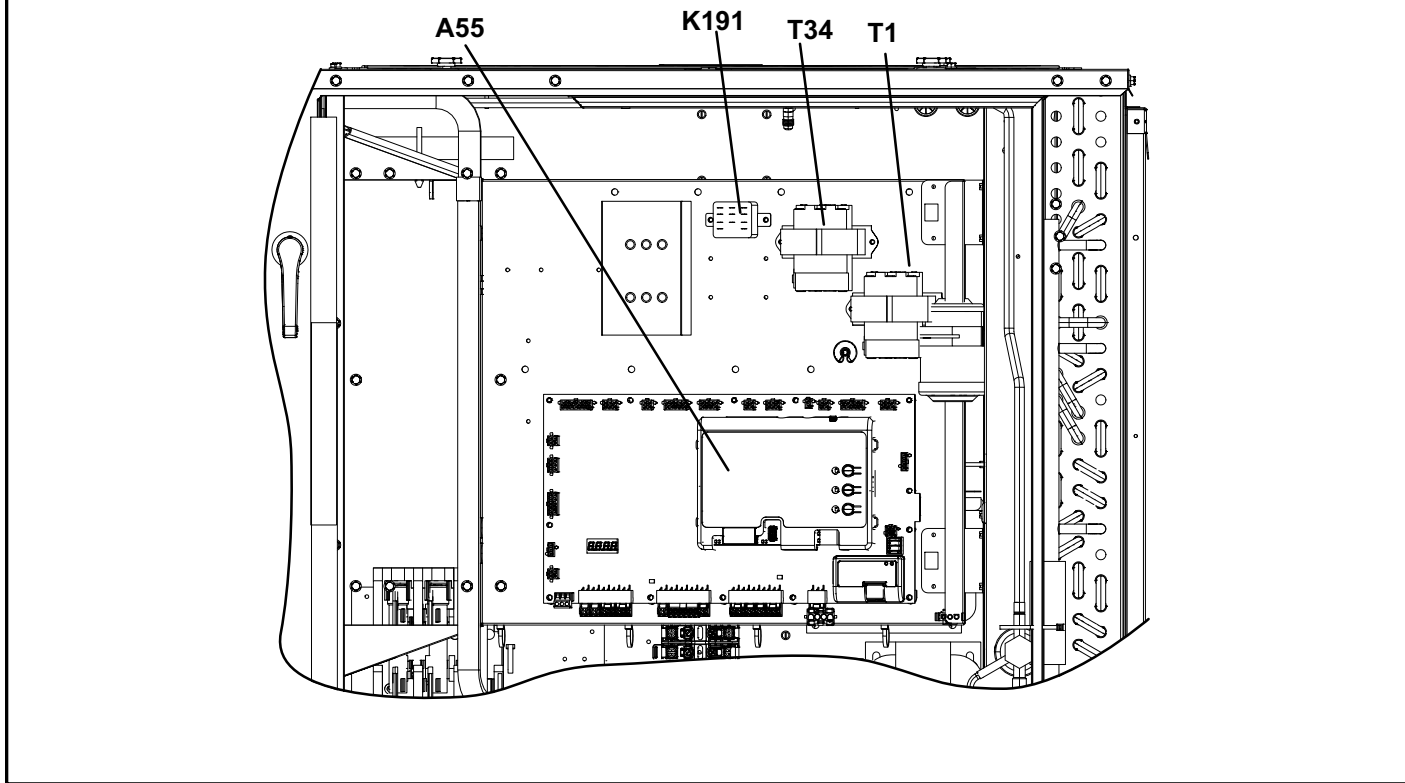

FIGURE 2

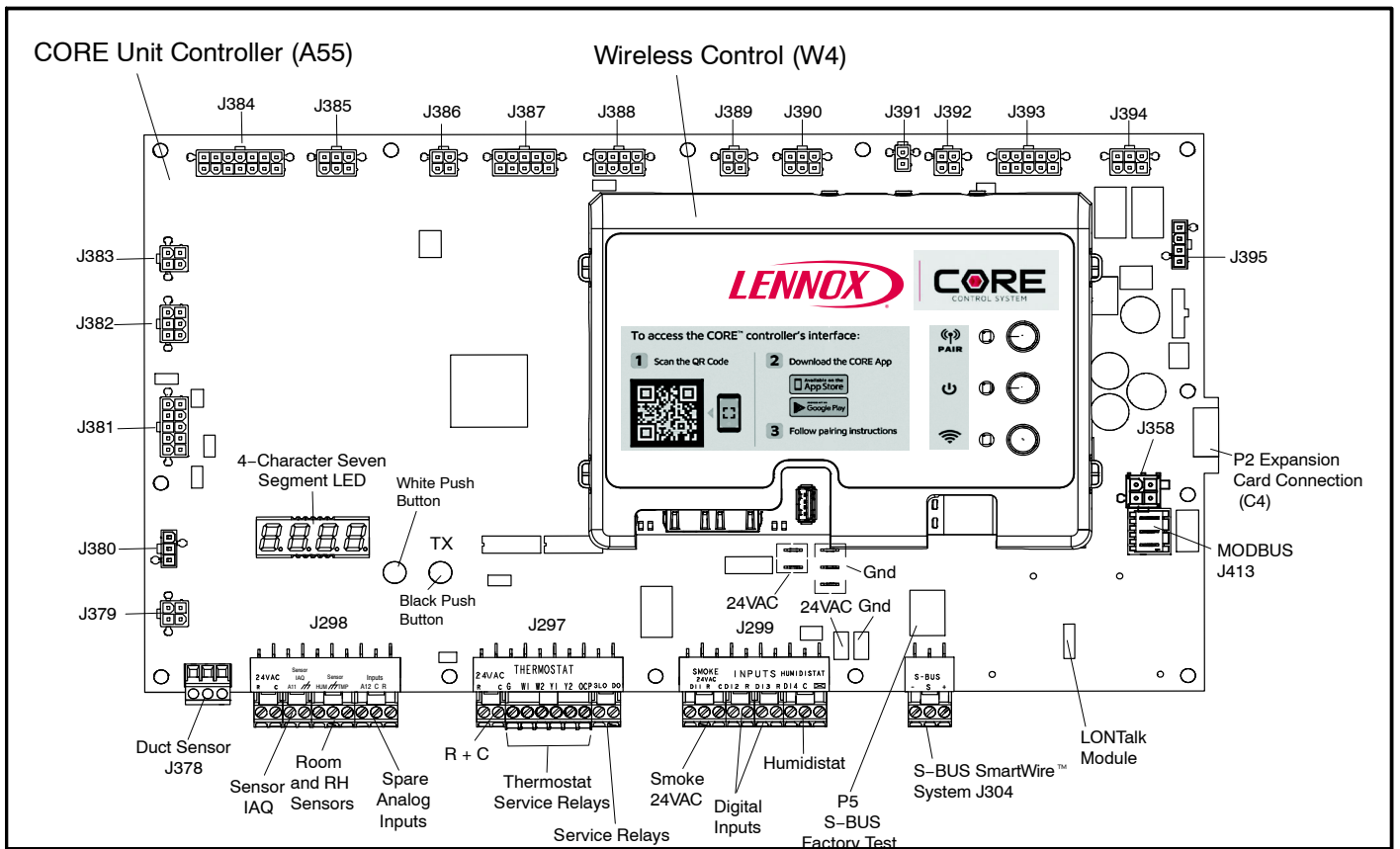

FIGURE 3

I-UNIT COMPONENTS

⚠ CAUTION

Electrostatic discharge can affect electronic components. Take precautions to neutralize electrostatic charge by touching your hand and tools to metal prior to handling the control.

All 2 through 5 ton (7 through 17.5 kW) units are configured to order units (CTO). The LDT unit components are shown in figure 1. All units come standard with hinged unit panels. All L1, L2, and L3 wiring is color coded; L1 is red, L2 is yellow, and L3 is blue.

A-Control Box Components

LDT control box components are shown in figure 2. The control box is located in the upper right portion of the compressor compartment.

1-Control Transformers T1/T43

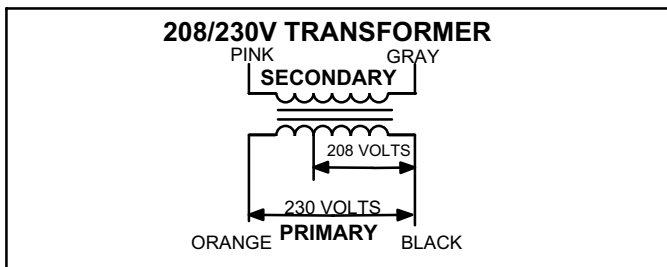

FIGURE 4

All use a single line voltage to 24VAC transformer mounted on the hinged control panel. Transformer supplies power to control circuits in the unit. The transformer is rated at 70VA and is protected by a 3.5 amp circuit (CB8). The 208/230 voltage transformers use two primary voltage taps as shown in figure 4, while the 460 (G) voltage transformer use a single primary voltage tap. T43 is used for units with hot gas reheat for additional 24VAC.

2-Transformer T4 (J voltage)

All J volt units are equipped with a line voltage to 460V 3-phase transformer to power the indoor blower motor. T4 is mounted in the back panel of the compressor section above T5.

3-Transformer T5 (G and J voltage)

All units use transformer T5 mounted in the back panel in the compressor section. T5 is a line voltage to 230V transformer to power the combustion air inducer, outdoor fan motor, and optional UVC light ballast. It is connected to line voltage and is powered at all times.

4-Unit Controller A55 (Figure 3)

The Unit Controller provides all unit control functions, unit status information, unit diagnostics, programmable parameters, and USB verification and profile sharing. The unit controller can only be interfaced with via the CORE Service mobile app. Refer to the Unit controller instructions provided for additional details on pairing and app functions

Attention!

Use this QR code to download the mobile service app. Follow the prompts to pair the app with the unit control system and configure the unit. Refer to the “Download Mobile App” section in this manual and the Setup Guide provided with this unit. The QR code is also available in the unit control area.



The app can be downloaded from the appropriate iOS or Android store. Look for the following



The Unit Controller uses input from a zone/room sensor cooling, a thermostat, or a third-party controller to operate the unit. Zone/room sensor, thermostat, and third-party controller wires are connected to J297 on the Unit Controller.

Many default Unit Controller settings are adjustable. Refer to the unit installation instruction or the Unit Controller manual provided with the unit.

The Unit Controller is configured to identify optional kits and accessories for proper function. Each character in the configuration ID represents a different option. Refer to the unit installation instruction or the Unit Controller manual provided with the unit.

5-Compressor Contactor K1

The Unit Controller closes n.o. K1 contacts to provide power to the inverter control board (A192). The contactor does not energize the compressor in the same manner as a traditional cooling system. Three phase units use three pole double break contactors with a 24 volt coil.

6-Crankcase Heater Relay K191

All units use relay K191 to control crankcase heater HR1.

7-Power Exhaust Relay K65 (PED units)

Power exhaust relay K65 is a N.O. DPDT relay with a 24VAC coil. K65 is used in all LDT units equipped with the optional power exhaust dampers. K65 is energized by the economizer control panel (A56), after the economizer dampers reach 50% open (adjustable in ECTO). When K65 closes, the exhaust fan B10 is energized.

B-Cooling Components

All units use a single cooling circuit consisting of a two-speed compressor, fin/tube condenser coil and evaporator coil. See figure 5. All units use one draw-through type condenser fan and a single direct drive blower. The blower draws air across the evaporator during unit operation.

Cooling may be supplemented by a factory- or field-installed economizer. The evaporator coil is slab type and uses a thermostatic expansion valve as the primary refrigerant metering device. The evaporator is also equipped with enhanced fins and rifled tubing. The compressor is protected by a high pressure switch (S4) on the discharge line, a high temperature limit switch (S5) on the compressor, and a low pressure switch (S87) on the suction line. See figure 5.

1-High Pressure Switch S4

The high pressure switch is an auto-reset SPST N.C. switch which opens on a pressure rise.

S4 is located in the compressor discharge line and wired to the A55 Unit Controller.

When discharge pressure rises to 640 ± 10 psig (4412 ± 69 kPa) (indicating a problem in the system) the switch opens and the compressor inverter is de-energized (the economizer can continue to operate). The switch automatically resets at 475 ± 10 psig.

2-Low Pressure Switch S87

The compressor circuit is protected by a loss of charge switch located on the suction line. Switch opens at 40 psig ± 5 psig (276 ± 34 kPa) and automatically resets at 90 psig ± 5 psig (621 kPa \pm kPa).

3-High Temperature Limit Switch S5

The variable speed compressor is equipped with a compressor-mounted normally closed temperature switch that prevents compressor damage due to overheating caused by internal friction. The switch is located on top of the compressor casing. This switch senses the compressor casing temperature and opens at 239 - 257°F to shut-off compressor operation. The auto-reset switch closes when the compressor casing temperature falls to 151 - 187°F , and the compressor is re-energized. This switch is a single-pole, single-throw (SPST) bi-metallic switch and is wired to the A55 Unit Controller.

4- Reversing Valve

A refrigerant reversing valve with a 24 volt solenoid coil is used to reverse refrigerant flow during unit operation in all LDT units. The reversing valve is connected in the vapor line of the refrigerant circuit. The reversing valve coil is energized during cooling demand and during defrost.

Reversing valve L1 is controlled by the A55 Control board in response to cooling demand or by defrost.

PLUMBING AND COMPRESSOR PROTECTION COMPONENTS

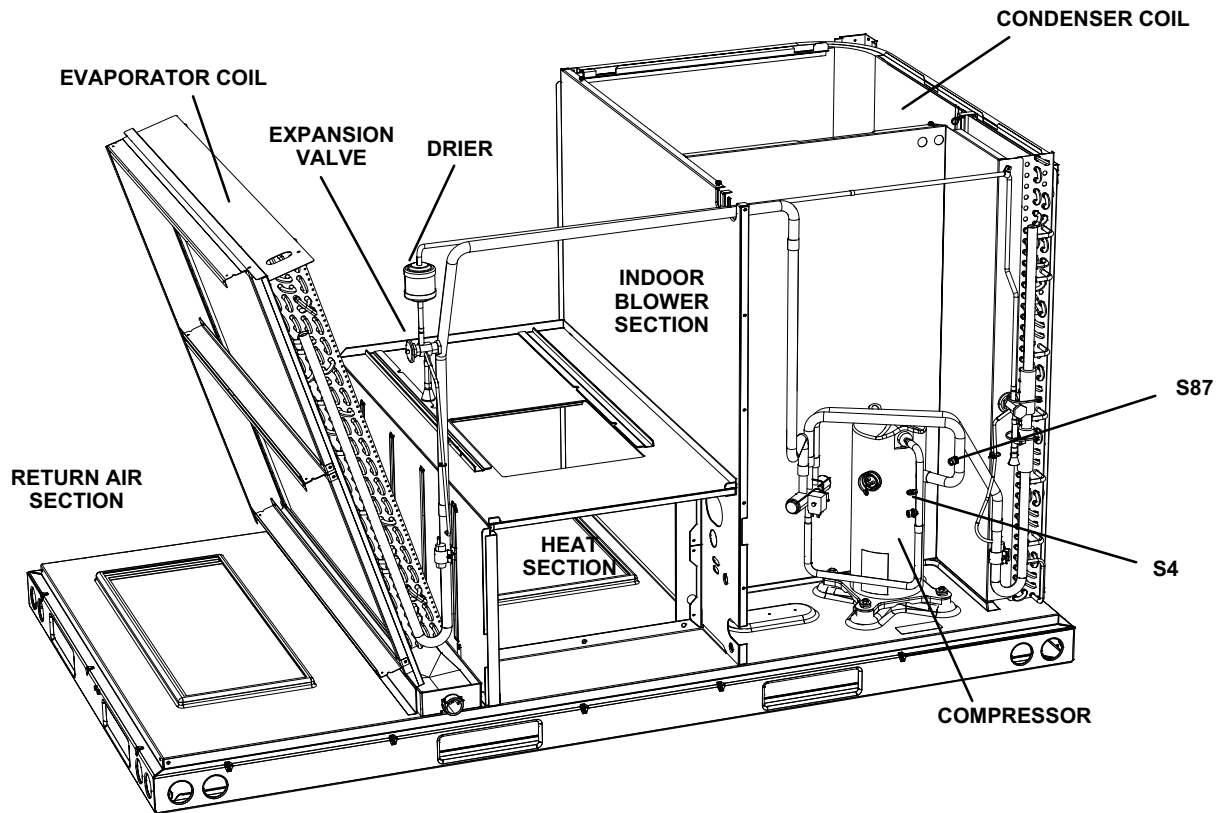

FIGURE 5

5-Thermistors

Units are equipped with two factory-installed thermistors (RT46 and RT48) located on different points on the refrigerant circuit.

The thermistors provide the Unit Controller with constant temperature readings of two specific locations on the refrigeration circuit. These temperatures are used as feedback in certain modes of unit operation. In addition, the Unit Controller uses these temperatures to initiate alarms such as loss of condenser or evaporator airflow and loss of charge.

Each thermistor must be specifically placed for proper unit operation and to initiate valid alarms. See table 1 for proper locations.

A-Freezesat

Thermistor RT46 monitors the temperature on the return bend of the indoor coil. If the temperature is measured below $32^{\circ}\text{F} \pm 3^{\circ}\text{F}$ ($0^{\circ}\text{C} \pm 1.7^{\circ}\text{C}$) for more than 3 minutes, the M4 control board will display a alarm, and will shut down compressor operation until coil warms sufficiently to melt any accumulated frost. At $58^{\circ}\text{F} \pm 4^{\circ}\text{F}$ ($14.4^{\circ}\text{C} \pm 2.2^{\circ}\text{C}$), the M4 control board will energize compressor. If compressor is frequently turning off due to coil icing, check the airflow, filters, and unit charge before allowing unit back in operation. Make sure to eliminate conditions which promote indoor coil ice buildup

TABLE 1
THERMISTOR LOCATION

Unit	Sensor Yellow	Figure
024, 036, 048 Indoor Coil	RT46	6
024, 036 Outdoor Coil	RT48	7
048 Outdoor Coil	RT48	8
060 Indoor Coil	RT46	9
060 Outdoor Coil	RT48	10

B-Low Ambient Operation

When Outdoor Air Temperature (OAT) drops below 62°F (16.6°C) while in cooling operation, the Unit will modulate OD fan in order to maintain coil temperature observed on RT48. Once OAT exceeds 65°F (18.3°C), unit will resume normal operation. The intermittent fan operation results in higher evaporating temperature allowing the system to operate without icing the evaporator coil and losing capacity.

C-Defrost Control

The defrost control ensures that the heat pump outdoor coil does not ice excessively during the heating mode. The defrost control uses input from the coil and ambient sensor to uses demand defrost cycles from the M4 board. If system fails to do calibration or obtain readings for demand defrost, it will run timed defrost at customer setting. If electric heat is installed, it is energized during defrost cycle.

LHT/LDT024, 036, 048
INDOOR COIL
RT46

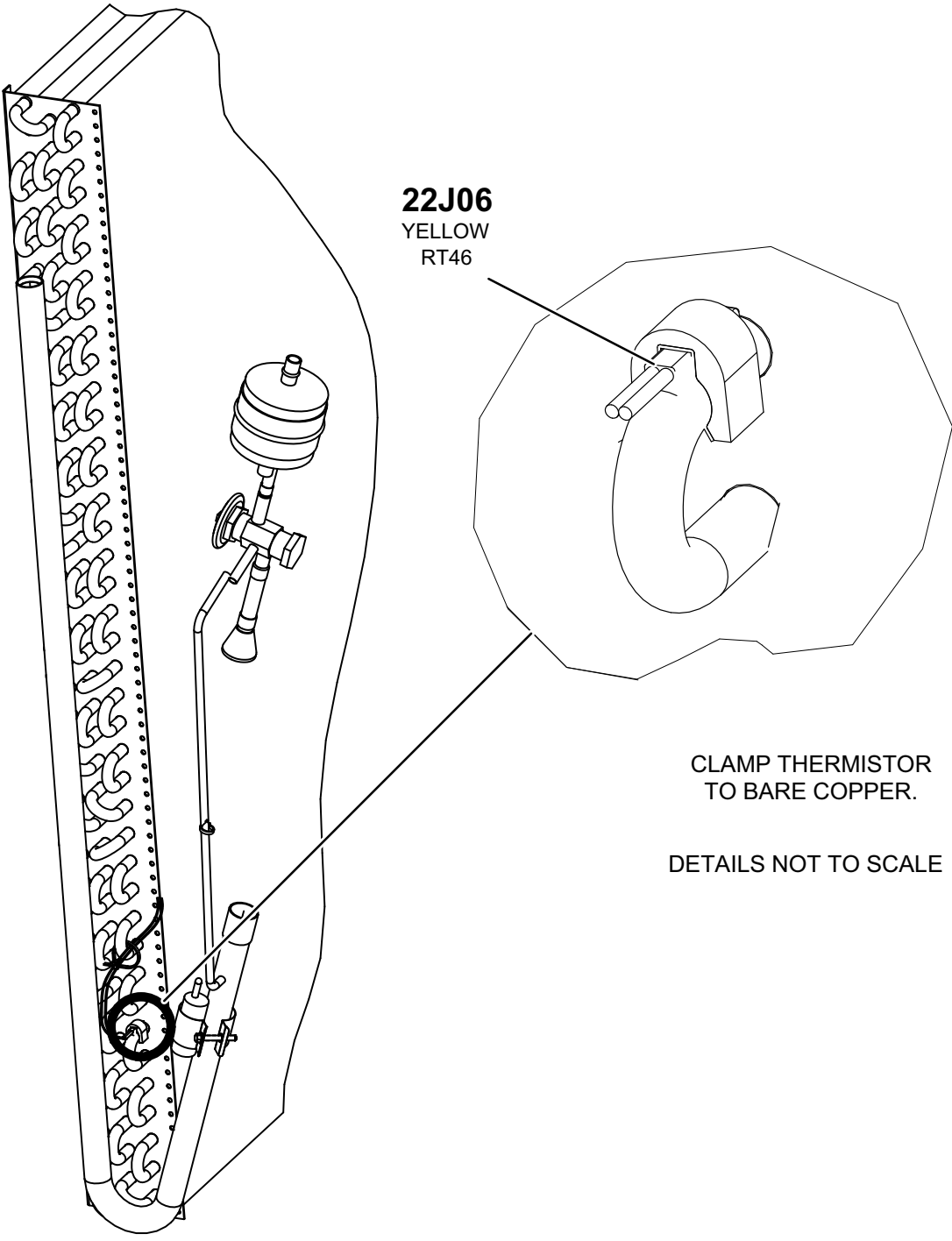

FIGURE 6

LHT/LDT024, 036
OUTDOOR COIL
RT48

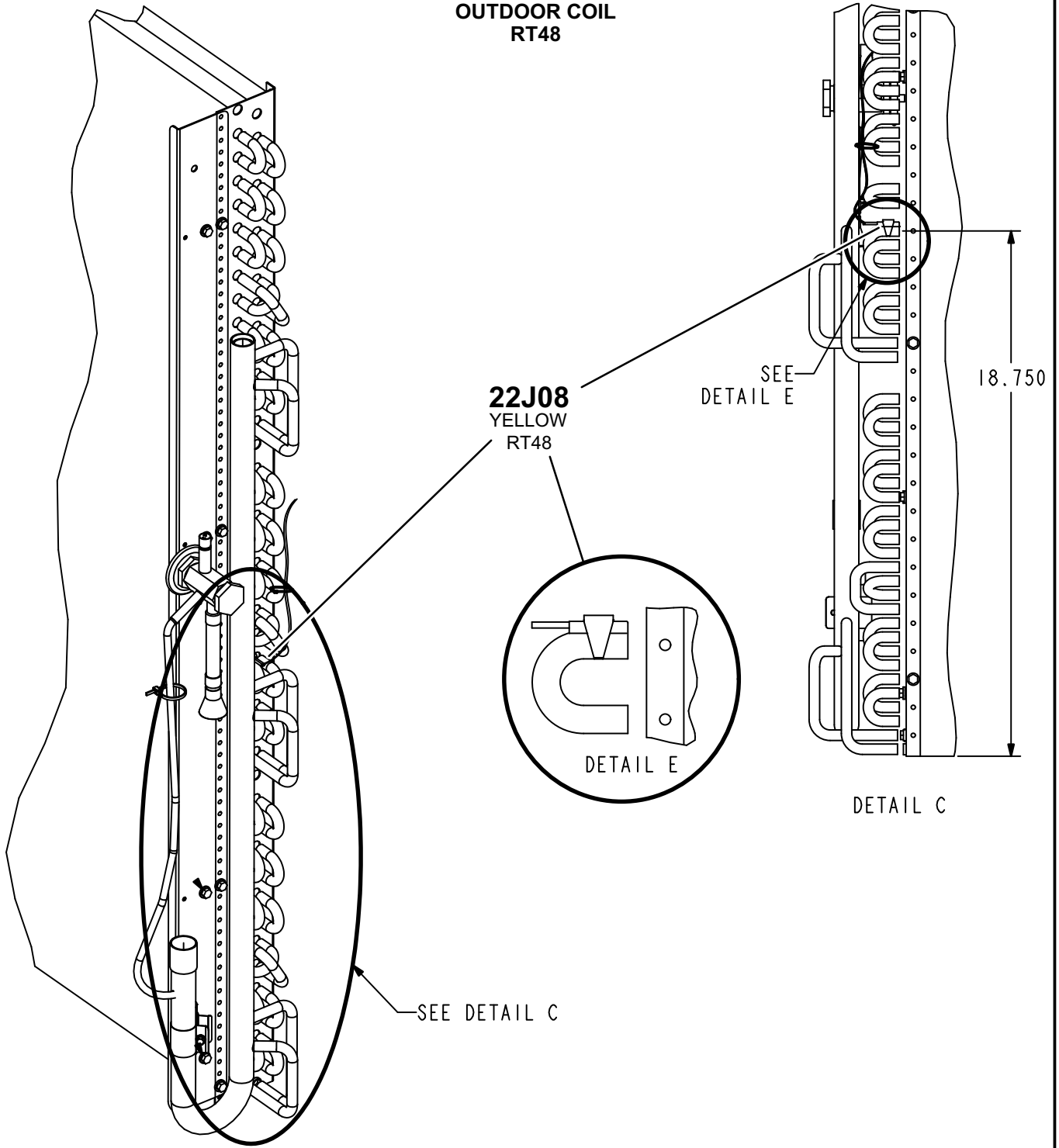
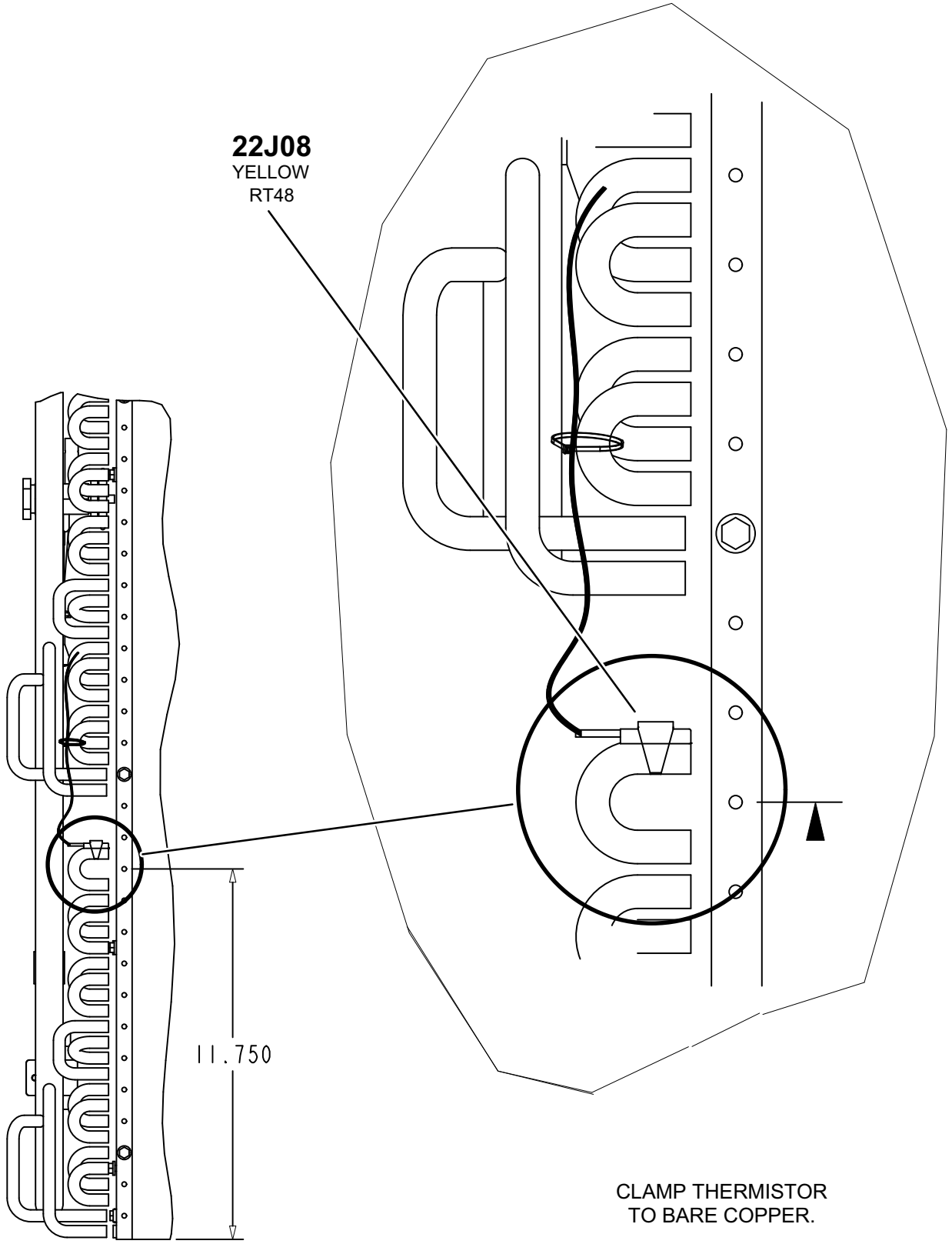

FIGURE 7

CLAMP THERMISTOR

LHT/LDT048
OUTDOOR COIL
RT48



22J08
YELLOW
RT48

11.750

CLAMP THERMISTOR
TO BARE COPPER.

DETAILS NOT TO SCALE

FIGURE 8

LHT/LDT060
INDOOR COIL
RT46

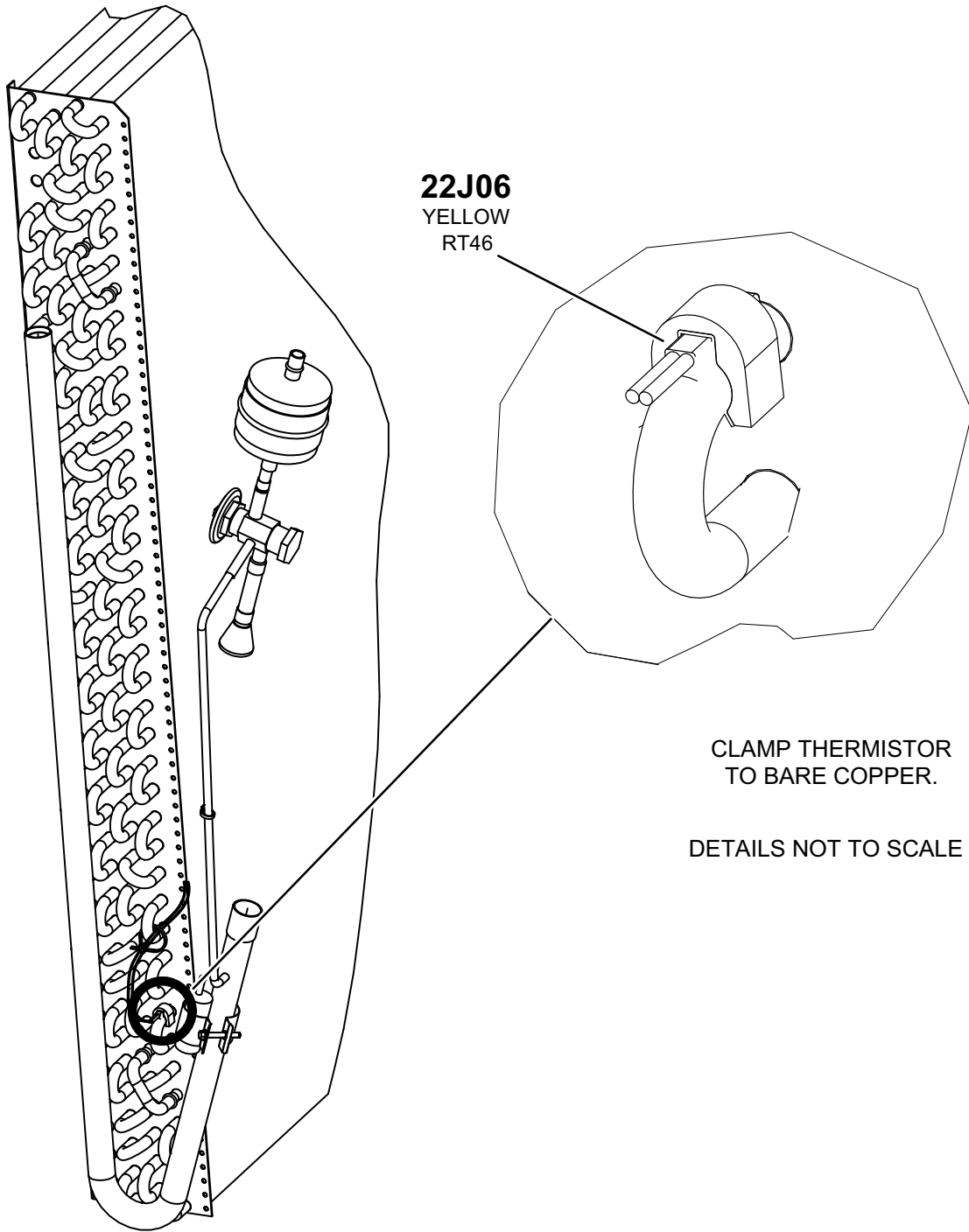
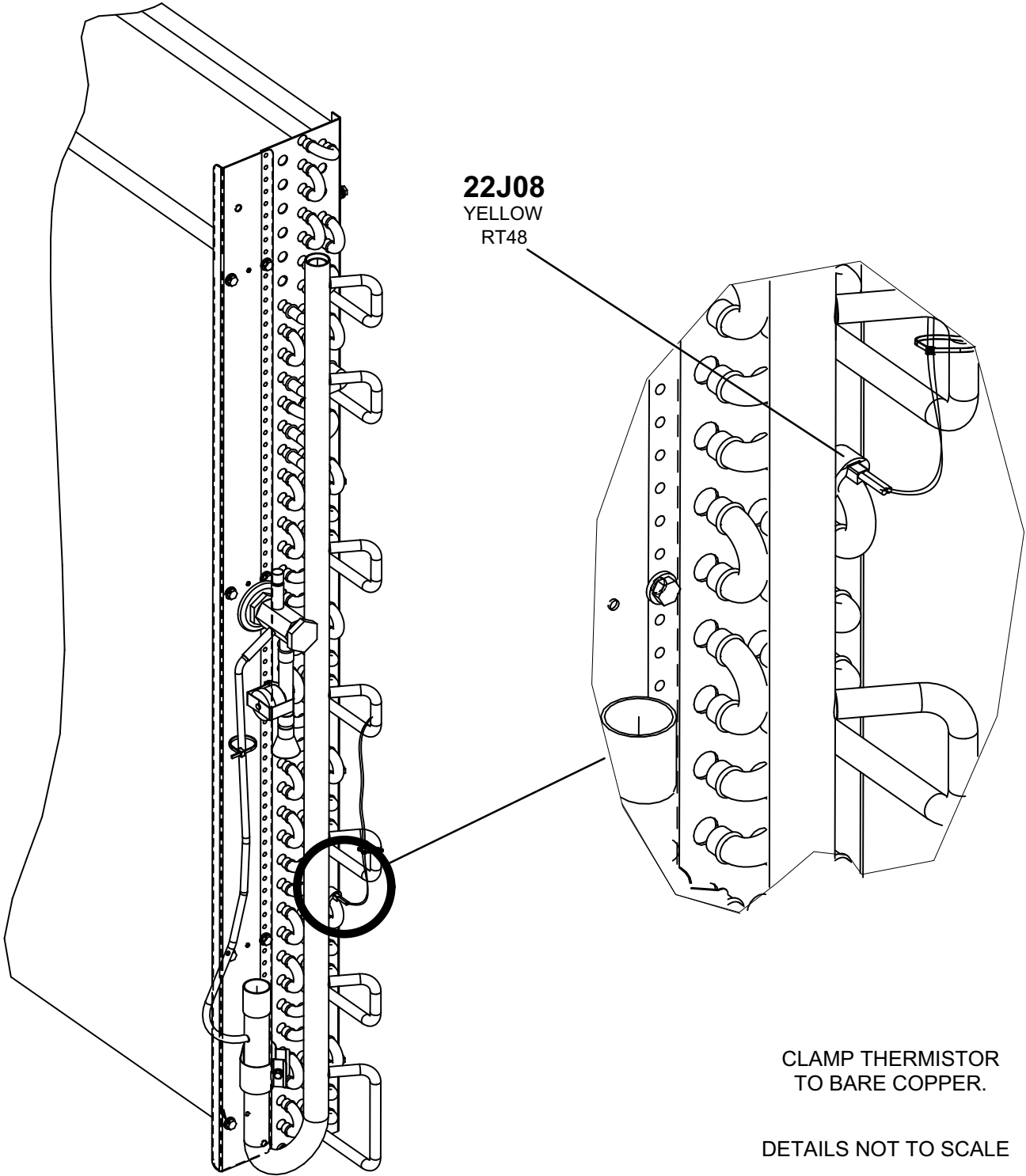

FIGURE 9

LHT/LDT060
OUTDOOR COIL
RT48

22J08
YELLOW
RT48



CLAMP THERMISTOR
TO BARE COPPER.

DETAILS NOT TO SCALE

FIGURE 10

⚠ WARNING

Electrical shock hazard. Compressor must be grounded. Do not operate without protective cover over terminals. Disconnect power before removing protective cover. Discharge capacitors before servicing unit. Failure to follow these precautions could cause electrical shock resulting in injury or death.

6-Two-Speed Compressor B1

All units use one two-speed scroll compressor. See "SPECIFICATIONS" and "ELECTRICAL DATA" (table of contents) or compressor nameplate for compressor specifications.

7-Compressor Crankcase Heater (HR1)

Crankcase heater must be energized at all times to prevent compressor damage due to refrigerant migration. Energize crankcase heater 24 hours before unit start-up by setting thermostat so that there is no cooling demand (to prevent compressor from cycling) and apply power to unit.

C-GAS HEAT COMPONENTS

LDT units are available with two stages of gas heat. See SPECIFICATION - GAS HEAT

1-Ignition Control A3

The ignition control provides three main functions: gas valve control, ignition, and flame sensing. The control has a red LED to show control status (table 2).

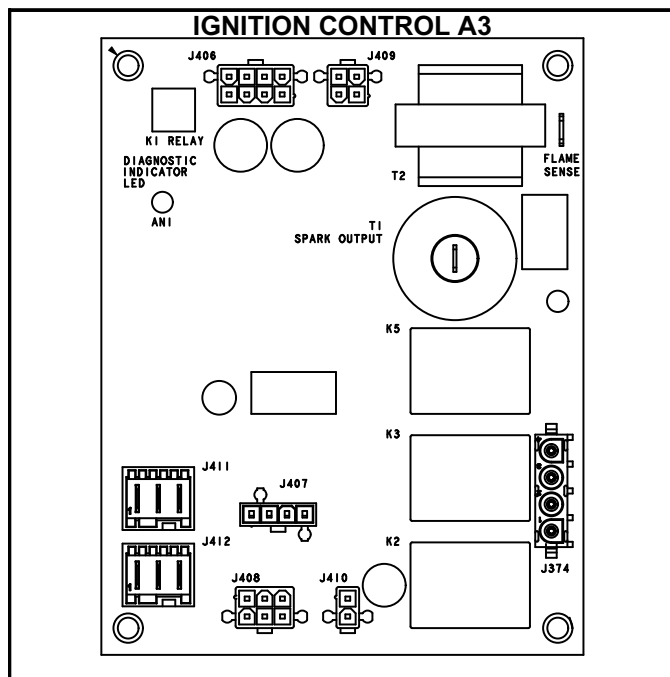

FIGURE 11

TABLE 2

LED Flashes	Indicates
Steady Off	No power or control hardware fault.
Steady On	Power applied. Control OK.
3 Flashes	Ignition lockout from too many trials.
4 Flashes	Ignition lockout from too many flame losses within single call for heat.
5 Flashes	Control hardware fault detected.

Flame rectification sensing is used on all LDT units. Loss of flame during a heating cycle is indicated by an absence of flame signal (0 microamps). If this happens, the control will immediately restart the ignition sequence and then lock out if ignition is not gained after the third trial. See System Service Checks section for flame current measurement.

The control shuts off gas flow immediately in the event of a power failure. Upon restoration of gas and power, the control will restart the ignition sequence and continue until flame is established or system locks out.

⚠ WARNING



Shock hazard. Spark related components contain high voltage which can cause personal injury or death. Disconnect power before servicing. Control is not field repairable. Unsafe operation will result. If control is inoperable, simply replace the entire control.

Operation

On a heating demand, the ignition control checks for a closed limit switch. Once this check is complete and conditions are correct, the ignition control then allows 30 seconds for the combustion air inducer to vent exhaust gases from the burners. When the combustion air inducer is purging the exhaust gases, the combustion air prove switch closes proving that the combustion air inducer is operating before allowing the ignition control to energize. When the combustion air prove switch is closed and the delay is over, the ignition control activates the gas valve(s), the spark electrode and the flame sensing electrode. At the start of the ignition sequence, the adjustable 40 second (default) indoor blower delay period begins. Sparking stops immediately after flame is sensed or at the end of the 8 second trial for ignition. If flame is not sensed, A3 or A12 will wait 5 minutes before attempting ignition again. If the third trial fails, A3 or A12 will lock-out for one hour. The A55 counts this as a **first** strike. After the first lock-out hour elapses, A3 or A12 will attempt ignition three more times. If flame is still not sensed, A3 or A12 will lock-out for the second hour. A55 counts this as the **second** strike. After the second lockout

hour, A3 or A12 will attempt ignition three more times. If ignition fails, A55 considers this the **third** strike and will lock-out unit operation. Service relay contacts close and alarm 59 or 69 is displayed. The unit will remain in lock-out until:

1-A55 is reset

or

2-The alarm condition is cleared **AND** the alarm status is read through the SBUS command.

Once the flame is sensed, the ignition control then proceeds to “steady state” mode where all inputs are monitored to ensure the limit switch, roll-out switch and prove switch are closed as well as flame is present. When the heat call is satisfied the gas valve and combustion air inducer are de-energized. An adjustable 120-second (default) blower off delay begins.

2-Primary High Temperature Limits S10

S10 is a SPST N.C. high temperature primary limit for gas heat. Limits are located on the vestibule panel for units with an ECM Blower (figure 13) or in the control box next to the discharge air sensor (figure 12)

Limits are wired to the A3 ignition control. N.C. contacts open to de-energize the ignition control when excessive temperature is reached in the blower compartment.

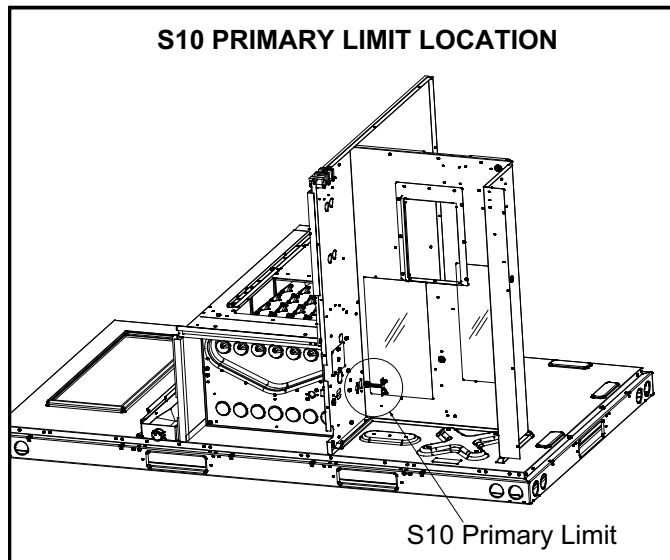

FIGURE 12

3-Heat Exchanger Figure 13

The LDT units use aluminized steel inshot burners with tubular aluminized (stainless is optional) steel heat exchangers and redundant gas valve. Burners in all units use a burner venturi to mix gas and air for proper combustion. Combustion takes place at each tube entrance. As hot combustion gases are drawn upward through each tube by the combustion air inducer, exhaust gases are drawn out the top and fresh air/gas mixture is drawn in at the bottom. Heat is transferred to the air stream from all surfaces of the heat exchanger tubes. The supply air blower forces air across the tubes to extract the heat of combustion. The shape of the tubes ensures maximum heat exchange.

The gas valves on two stage units accomplish staging by allowing more or less gas to the burners as called for by heating demand.

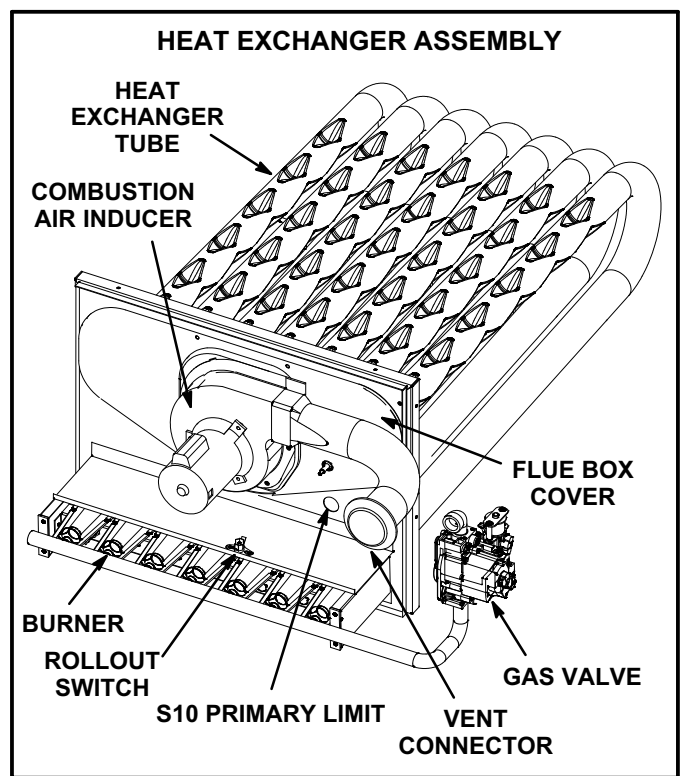

FIGURE 13

4-Burner Box Assembly Figure 14

The burner assembly consists of a spark electrode, flame sensing electrode and gas valve. Ignition board A3 and A12 control all functions of the assembly.

Burners

All units use inshot burners. Burners are factory set and do not require adjustment. A peep hole with cover is furnished in the heating access panel for flame viewing. Always operate the unit with the access panel in place.

Burners can be removed individually for service on older units. On newer units, burners are connected and the entire assembly can be removed. Burner maintenance and service is detailed in the SERVICE CHECKS section of this manual. See figure 15 for number of burners.

Orifice

Each burner uses an orifice which is matched to the burner input. The orifice is threaded into the burner manifold. The burner is supported by the orifice and will easily slide off for service once the mounting screws are removed from the burners.

NOTE - Do not use thread sealing compound on the orifices. Using thread sealing compound may plug the orifices.

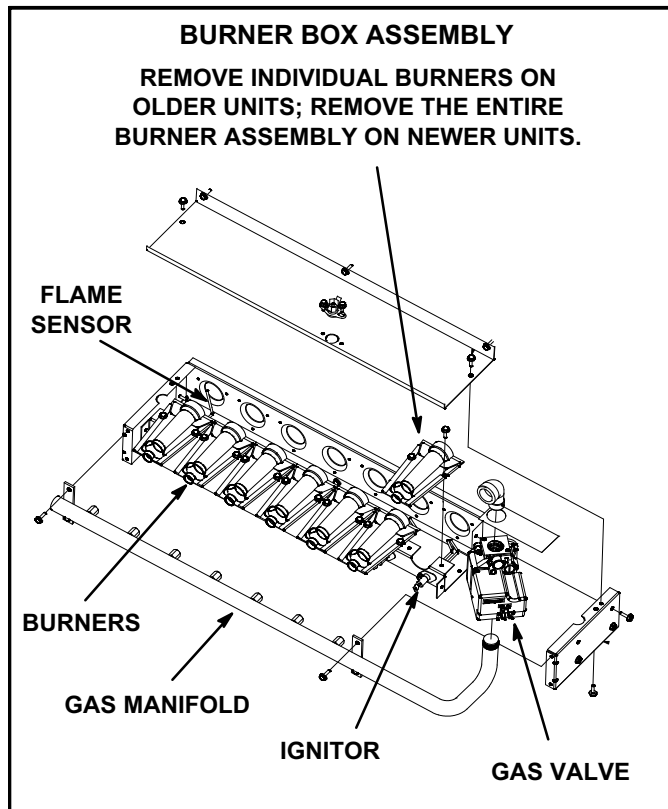

FIGURE 14

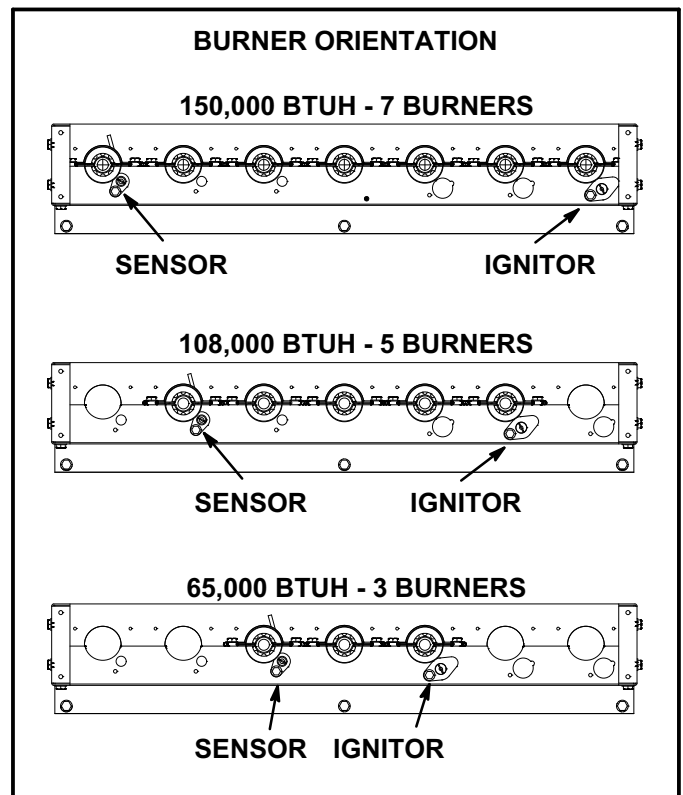

FIGURE 15

5-Flame Roll-out Limit Switch S47

The flame roll-out limit switch is a SPST N.C. high temperature limit located just above the burner air intake opening in the burner enclosures. The switch is wired to the A3 ignition controller. When the limit switch senses flame roll-out (indicating a blockage in the combustion air passages), the flame roll-out limit trips, and the Unit Controller immediately closes the gas valve.

Limit is factory preset to open at $340^{\circ}\text{F} \pm 16^{\circ}\text{F}$ on a temperature rise on all units. All flame roll-out limits are manual reset.

6-Combustion Air Prove Switch S18

Prove switch S18 is a SPST N.O. switch located to the right of the induced draft assembly. See figure 16. S18 monitors combustion air inducer operation. Switch S18 is wired to A3 ignition controller which checks its status upon a call for heating. The switch closes at *negative* $0.10''\text{W.C.} + 0.05''$ ($24.8\text{ Pa} + 12.4\text{ Pa}$) on pressure fall. This negative pressure fall and switch actuation allows the ignition sequence to continue (proves, by closing, that the combustion air inducer is operating before allowing the gas valve to open.) The combustion air prove switch is factory set and not adjustable.

7-Combustion Air Motor Capacitor C3

The combustion air inducer motors in all LDT units require run capacitors. Capacitor C3 is connected to combustion air inducer B6. Ratings will be on side of capacitor or combustion air motor nameplate.

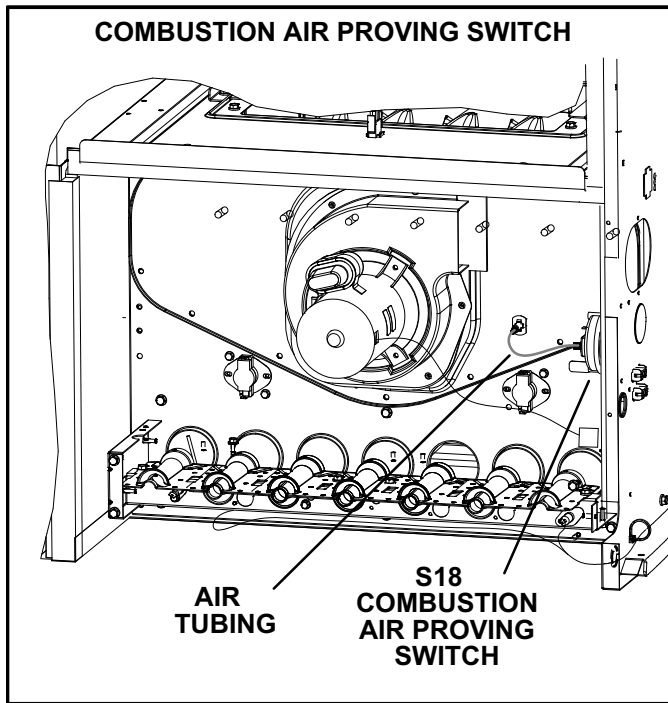

FIGURE 16

8-Combustion Air Inducer B6

Combustion air inducers provide air to the corresponding burners while clearing the combustion chamber of exhaust gases. The inducer begins operating immediately upon receiving a thermostat demand and is de-energized when thermostat demand is satisfied.

The inducer uses a 208/230V single-phase PSC motor and a 5.24 in. x .96in. blower wheel. All motors operate at 3300RPM and are equipped with auto-reset overload protection. Two-speed units have reduced RPM for low speed. Inducers are supplied by various manufacturers. Ratings may vary by manufacturer. Specific inducer electrical ratings can be found on the unit rating plate.

The ignition control board energizes an internal relay to route power to the combustion air blower motor. A3 then allows 30 to seconds for the combustion air inducer to vent exhaust gases from the burners. When the combustion air inducer is purging the exhaust gases, the combustion air prove switch closes, proving that the combustion air inducer is operating before allowing the ignition sequence to continue. When the combustion air prove switch is closed and the delay is over, the A3 ignition control activates the appropriate stage operator of the gas valve, the spark and the flame sensing electrode. Sparking stops immediately after flame is sensed or at the end of the eight second trial for ignition.

On two-stage natural gas units, the inducer will operate on low speed for first stage heat (W1) and ramp up to high speed for second stage heat (W2).

All combustion air inducer motors are sealed and cannot be oiled. The inducer cannot be adjusted but can be removed from the heat section for cleaning.

9-Gas Valves GV1

Units are equipped with a two-stage gas valve. When a heating demand is present, the valve is energized in low fire by the ignition control at the same time as the spark electrode.

If the heating demand increases, the high fire signal is provided by the ignition controller. Both the low fire and high fire signals are required for the gas valve to operate in high fire.

A shut-off knob/switch is provided on the valve for manual shut-off. The shut-off knob/switch will immediately close both stages without delay.

Both low fire and high fire (if applicable) valve outputs are adjustable. Figure 20 shows gas valve components. Table 3 shows factory gas valve operating manifold pressures.

TABLE 3

Operating Manifold Pressure			
Natural		L.P.	
Low	High	Low	High
2.0 ± 0.3" W.C.	3.5 ± 0.3" W.C.	5.9" ± 0.3" W.C.	10.5" ± 0.5" W.C.

The gas manifold pressure should be adjusted when the unit is installed at altitudes higher than 2000 feet. See HIGH ALTITUDE table in SPECIFICATIONS - GAS HEAT

10-Spark Electrode (Ignitor) Figure 17

An electrode assembly is used for ignition spark. The electrode is inserted through holes in the burner support. See figure 15. The electrode tip protrudes into the flame envelope of the adjacent burner. The electrode assembly is fastened to burner supports and can be removed for service without removing any part of the burners.

During ignition, spark travels through the spark electrode (figure 17) and ignites the appropriate burner depending on the heating stage. Flame travels from burner to burner until all are lit.

The spark electrode is connected to the ignition control by a 8 mm silicone-insulated stranded high voltage wire. The wire uses 1/4" (6.35 mm) female quick connect on both ends of the wire.

NOTE - If electrode wire must be replaced, wire and suppression must be same type cable.

The spark electrode assembly can be removed for inspection by removing the screw securing the electrode assembly and sliding it out of unit.

For proper unit operation, electrodes must be positioned and gapped correctly.

Spark gap may be checked with appropriately sized twist drills or feeler gauges. Disconnect power to the unit and remove electrode assembly. The gap should be between 0.125" ± 0.015" (3.2 mm ± .4 mm). See figure 17.

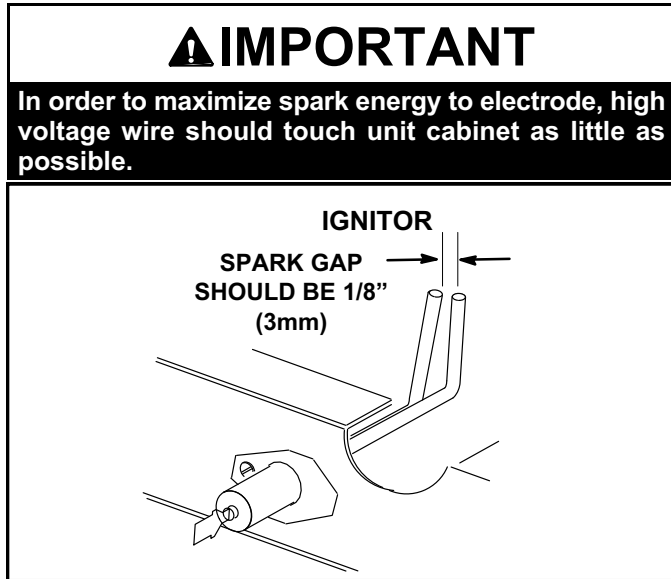

FIGURE 17

11-Flame Sensor Figure 18

The flame sensor is mounted through a hole in the burner support and the tip protrudes into the flame envelope of the appropriate burner. See figure 15 for location. The sensor assembly is fastened to burner supports and can be removed for service without removing any part of the burners.

When flame is sensed by the flame sensor (indicated by microamp signal through the flame) sparking stops immediately or after the eight second trial for ignition. During operation, flame is sensed by current passed along the ground electrode (located on the spark electrode), through the flame and into the sensing electrode. The ignition control allows the gas valve to stay open as long as a flame signal (current passed through the flame) is sensed.

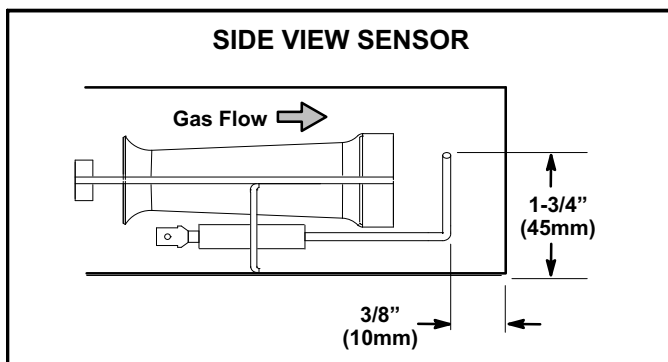

FIGURE 18

D-BLOWER COMPARTMENT

Units are equipped with a variable speed, direct drive blower. The installer is able to enter the design-specified supply air CFM into the Unit Controller for optimal efficiency. The Unit Controller calibrates the supply air volume which eliminates the need to manually take duct static measurements.

1-Indoor Blower Motor B3

All direct drive blower motors are electronically commutated, brushless, DC motors. CFM adjustments are made by changing Unit Controller parameters via the service app. Motors are equipped with sealed ball bearings. All motor specifications are listed in the SPECIFICATIONS (table of contents) in the front of this manual. Motors come with pre-mounted aluminum impellers.

⚠ IMPORTANT

Three phase scroll compressors must be phased sequentially for correct compressor and blower rotation. Follow "COOLING START-UP" section of installation instructions to ensure proper compressor and blower operation.

A-Blower Operation

Refer to the Unit Controller Setup Guide to energize blower. Use the mobile service app menu; see *RTU MENU>COMPONENT TEST>BLOWER>START TEST*

⚠ WARNING

- 1-Make sure that unit is installed in accordance with the installation instructions and applicable codes.
- 2-Inspect all electrical wiring, both field- and factory-installed, for loose connections. Tighten as required.
- 3-Check to ensure that refrigerant lines do not rub against the cabinet or against other refrigerant lines.
- 4-Check voltage at disconnect switch. Voltage must be within range listed on nameplate. If not, consult power company and have voltage condition corrected before starting unit.
- 5-Make sure filters are new and in place before start-up.

Direct-drive motor may not immediately stop when power is interrupted to the Unit Controller. Disconnect unit power before opening the blower compartment. The Controller's digital inputs must be used to shut down the blower. See Unit Controller manual for operation sequences.

B-Determining Unit CFM

- 1- The following measurements must be made with air filters in place.
- 2- With all access panels in place, measure static pressure external to unit (from supply to return). Blower performance data is based on static pressure readings taken in locations shown in figure 19.

Note - Static pressure readings can vary if not taken where shown.

- 3- Measure the indoor blower wheel RPM.
- 4- Referring to the Blower Data tables, use static pressure and RPM readings to determine unit CFM. Use the Accessory Air Resistance tables when installing units with any of the options or accessories listed. Refer to table 4 for minimum airflow when electric heat is installed.
- 5- From the mobile service app, use TEST & BALANCE > BLOWER menu to modify the following blower parameters:
 - HEATING HIGH CFM
This is the percentage of torque for blower heating speed.
 - HEATING LOW CFM
This is the percentage of torque for blower heating low speed on single phase gas heating units only.
 - COOLING HIGH CFM
This is the percentage of torque for blower cooling high speed. For 024 units, this is the only cooling speed.
 - COOLING LOW CFM
This is the percentage of torque for blower cooling low

speed (036, 048, and 060 units only) and vent speed for standard static blowers (all units).

•VENTILATION CFM

This is the percentage of torque for high static blower ventilation speed.

**TABLE 4
ELECTRIC HEAT MINIMUM AIRFLOW**

kW	CFM	
	Direct Drive	Direct Drive (Impeller-Style)
5	600	NA
7.5	600	1200
10	600	NA
15	1100	1500
22.5	1600	2000

C-Adjusting Unit CFM

The supply CFM can be adjusted by changing Unit Controller settings. Refer to table 5 for menu paths and default settings. Record any CFM changes on the parameter settings label located on the inside of the compressor access panel.

IMPORTANT - The default value for Cooling Low CFM is lower than a traditional single- or two-speed blower. If operating the unit with a 2- or 3-stage controller (2- or 3-stage thermostat, DDC controller, etc.), it is recommended to increase the Cooling Low CFM default value to a suitable level for part load cooling (typically 60% of full load CFM).

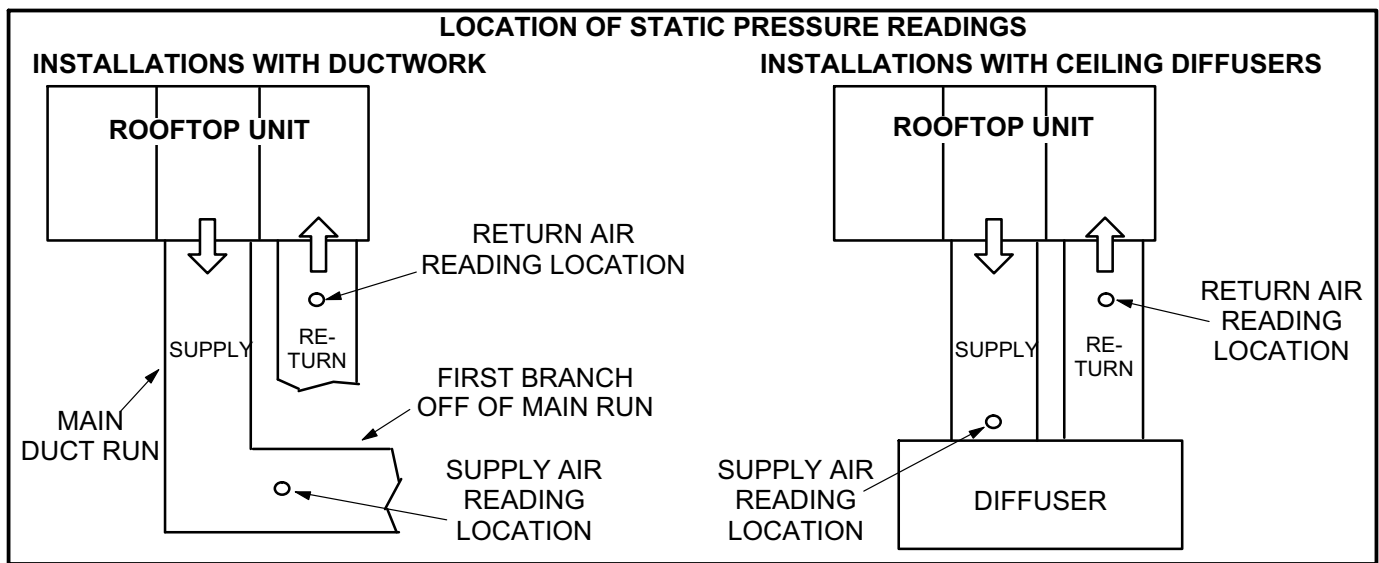

FIGURE 19

**TABLE 5
DIRECT DRIVE PARAMETER SETTINGS - 581102-01**

024-072 Parameter Settings		
Parameter	Field Setting	Description
Note: Any changes to Smoke CFM setting must be adjusted before the other CFM settings. Use SETTINGS > RTU OPTIONS > EDIT PARAMETERS = 12 for EBM, 6 for ECM		
BLOWER SMOKE CFM	%	Percentage of torque for blower smoke speed.
SETUP > TEST & BALANCE > BLOWER		
BLOWER HEATING HIGH CFM	%	Percentage of torque for blower heating high speed.
BLOWER HEATING LOW CFM	%	Percentage of torque for blower heating low speed (P volt gas heat only).
BLOWER COOLING HIGH CFM	%	Percentage of torque for blower cooling high speed.
BLOWER COOLING LOW CFM	%	Percentage of torque for blower cooling low speed and vent speed for standard static blowers.
BLOWER VENTILATION CFM	%	Percentage of torque for high static blower ventilation speed.
SETUP > TEST & BALANCE > DAMPER		
BLOWER HIGH CFM DAMPER POS %	%	Minimum damper position for high speed blower operation. Default 0%.
BLOWER LOW CFM DAMPER POS %	%	Minimum damper position for low speed blower operation. Default 0%.
POWER EXHAUST DAMPER POS %	%	Minimum damper position for low power exhaust operation. Default 50%.
SETTINGS > RTU OPTIONS > EDIT PARAMETERS = 216		
POWER EXHAUST DEADBAND %	%	Deadband % for power exhaust operation. Default 10%.
SETTINGS > RTU OPTIONS > EDIT PARAMETERS = 10 (Applies to Thermostat Mode ONLY)		
FREE COOLING STAGE-UP DELAY	sec	Number of seconds to hold blower at low speed before switching to blower at high speed. Default 300 seconds.

Installer: Record any parameter changes under "Field Setting" column. Settings need to be recorded by installer for use when Unit Controller is replaced or reprogrammed.

II-PLACEMENT AND INSTALLATION

Make sure the unit is installed in accordance with the installation instructions and all applicable codes. See accessories section for conditions requiring use of the optional roof mounting frame (T1CURB-AN or C1CURB-AN).

III-START UP - OPERATION

A-Preliminary and Seasonal Checks

- 1- Make sure the unit is installed in accordance with the installation instructions and applicable codes.
- 2- Inspect all electrical wiring, both field and factory installed for loose connections. Tighten as required. Refer to unit diagram located on inside of unit compressor access panel.
- 3- Check to ensure that refrigerant lines are in good condition and do not rub against the cabinet or other refrigerant lines.
- 4- Check voltage at the disconnect switch. Voltage must be within the range listed on the nameplate. If not, consult the power company and have the voltage corrected before starting the unit.
- 5- Recheck voltage and amp draw with unit running. If voltage is not within range listed on unit nameplate, stop unit and consult power company. Refer to unit nameplate for maximum rated load amps.

B-Heating Start up

Heat Pump Mode

In heat pump heating, 024 units will automatically stage-up for outdoor temperatures below 40°F (for increased performance and efficiency). No external demand is required, this operation is completely automatic. At temperatures above 40°F, compressor will automatically stage-down to maintain operational efficiency.

Note - L1 reversing valve is de-energized in the heating mode.

- 1- Set thermostat or temperature control device to initiate a first-stage heating demand.
- 2- Outdoor Temperature **ABOVE** Balance Point Setpoint (35°F default):
A first-stage heating demand (W1) will energize compressor **heat pump heating**, the outdoor fan, and the blower.
A second-stage heating demand (W2) will de-energize compressor heat pump heating through K27. **High gas heat** will be energized.
- 3- Outdoor Temperature **BELOW** Balance Point Setpoint (35°F default):
A first-stage heating demand (W1) will energize **low gas heat** and the blower motor.
A second-stage heating demand (W2) will energize **high gas heat**.

Gas Heat

FOR YOUR SAFETY READ BEFORE LIGHTING

BEFORE LIGHTING smell all around the appliance area for gas. Be sure to smell next to the floor because some gas is heavier than air and will settle on the floor.

⚠ WARNING



Electric shock hazard. Can cause injury or death. Do not use this unit if any part has been under water. Immediately call a qualified service technician to inspect the unit and to replace any part of the control system and any gas control which has been under water.

⚠ WARNING



Danger of explosion. Can cause injury or product or property damage. If overheating occurs or if gas supply fails to shut off, shut off the manual gas valve to the appliance before shutting off electrical supply.

⚠ WARNING



Electric shock hazard. Can cause injury or death. Before attempting to perform any service or maintenance, turn the electrical power to unit OFF at disconnect switch(es). Unit may have multiple power supplies.

⚠ WARNING

SMOKE POTENTIAL

The heat exchanger in this unit could be a source of smoke on initial firing. Take precautions with respect to building occupants and property. Vent initial supply air outside when possible.

The gas valve may be equipped with either a gas control lever or gas control knob. Use only your hand to push the lever or turn the gas control knob. Never use tools. If the lever will not move or the knob will not push in or turn by hand, do not try to repair it. Call a qualified service technician. Force or attempted repair may result in a fire or explosion.

⚠ WARNING



Danger of explosion. Can cause injury or death. Do not attempt to light manually. Unit has a direct spark ignition system.

This unit is equipped with an automatic spark ignition system. There is no pilot. In case of a safety shutdown, move thermostat switch to **OFF** and return the thermostat switch to **HEAT** to reset ignition control.

Placing Unit In Operation

⚠ WARNING

Danger of explosion and fire. Can cause injury or product or property damage. You must follow these instructions exactly.

Gas Valve Operation (figure 20)

- 1- Set thermostat to lowest setting.
 - 2- Turn off all electrical power to appliance.
 - 3- This appliance is equipped with an ignition device(s) which automatically lights the burner. Do **not** try to light the burner by hand.
 - 4- Open or remove the heat section access panel.
 - 5- Move gas valve switch(es) to **OFF**. See figure 20.
 - 6- Wait five (5) minutes to clear out any gas. If you then smell gas, **STOP!** Immediately call your gas supplier from a neighbor's phone. Follow the gas supplier's instructions. If you do not smell gas, go to the next step.
 - 7- Move gas valve switch(es) to **ON**. See figure 20.
 - 8- Close or replace the control access panel.
 - 9- Turn on all electrical power to appliance.
 - 10- Set thermostat to desired setting.
- NOTE - When unit is initially started, steps 1 through 9 may need to be repeated to purge air from gas line.*
- 11- The ignition sequence will start.
 - 12- If the furnace does not light the first time (gas line not fully purged), it will attempt up to two more ignitions before locking out.
 - 13- If lockout occurs, repeat steps 1 through 10.
 - 14- If the appliance will not operate, follow the instructions "Turning Off Gas to Appliance" and call your service technician or gas supplier.

Turning Off Gas to Unit

- 1- If using an electromechanical thermostat, set to the lowest setting.
- 2- Before performing any service, turn off all electrical power to the appliance.
- 3- Open or remove the control access panel.
- 4- Move gas valve switch(es) to **OFF**.
- 5- Close or replace the control access panel.

⚠ WARNING

Danger of explosion. Can cause injury or death. Do not attempt to light manually. Unit has a direct spark ignition system.

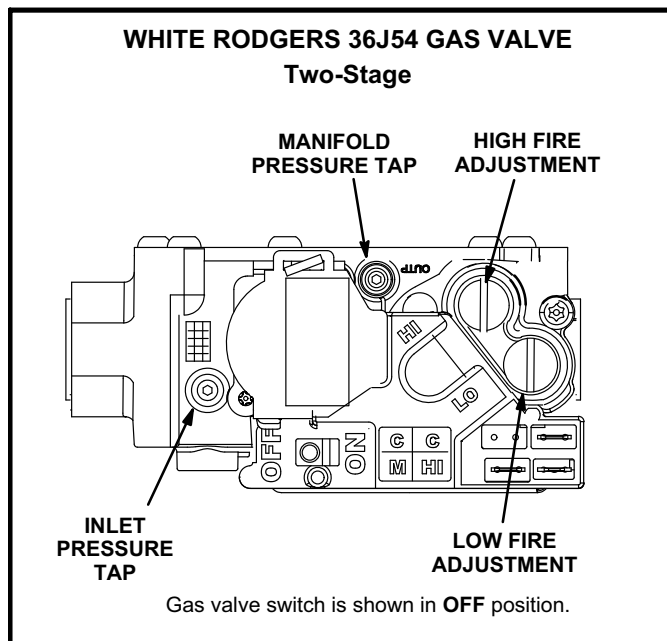

FIGURE 20

C-Cooling Start up A-Operation

- 1- Initiate full load cooling operation using the following mobile service app menu path:
RTU MENU > COMPONENT TEST > COOLING > COOLING STAGE 2
- 2- Units contain one refrigerant circuit or stage.
- 3- Unit is charged with R-410A refrigerant. See unit rating plate for correct amount of charge.
- 4- Refer to charging section method to check refrigerant charge.

D-Safety or Emergency Shutdown

Turn off power to unit. Close manual and main gas valves.

IV-CHARGING

C-Refrigerant Charge and Check - Fin/Tube Coil

WARNING-Do not exceed nameplate charge under any condition.

This unit is factory charged and should require no further adjustment. If the system requires additional refrigerant, reclaim the charge, evacuate the system, and add required nameplate charge.

*NOTE - System charging is not recommended below 60°F (15°C). In temperatures below 60°F (15°C) , the charge **must** be weighed into the system.*

If weighing facilities are not available, or to check the charge, use the following procedure:

- 1- Attach gauge manifolds and operate unit in cooling mode on **HIGH SPEED** with economizer disabled until system stabilizes (approximately five minutes). Make sure outdoor air dampers are closed.

Note - Use mobile service app menu path RTU MENU > COMPONENT TEST > COOLING > COOLING STAGE 2

- 2- Use a thermometer to accurately measure the outdoor ambient temperature.
- 3- Apply the outdoor temperature to tables 6 through 9 to determine normal operating pressures. Pressures are listed for sea level applications at 80°F dry bulb and 67°F wet bulb return air.
- 4- Compare the normal operating pressures to the pressures obtained from the gauges. Minor variations in these pressures may be expected due to differences in installations. Significant differences could mean that the system is not properly charged or that a problem exists with some component in the system. **Correct any system problems before proceeding.**
- 5- If discharge pressure is high, remove refrigerant from the system. If discharge pressure is low, add refrigerant to the system.
 - Add or remove charge in increments.
 - Allow the system to stabilize each time refrigerant is added or removed.

- 6- Use one of the following charge verification methods along with the normal operating pressures to confirm readings.

Charge Verification - Approach Method - AHRI Testing

- 1- Using the same thermometer, compare liquid temperature to outdoor ambient temperature.
Approach Temperature = Liquid temperature (at condenser outlet) minus ambient temperature.
- 2- Approach temperature should be 3.8°F + 1 (2.1°C + 0.5). An approach temperature greater than this value indicates an under-charge. An approach temperature less than this value indicates an overcharge.
- 3- The approach method is not valid for grossly over or undercharged systems. Use table 10 as a guide for typical operating pressures.

**TABLE 6 581065-01
024 NORMAL OPERATING PRESSURES**

Outdoor Coil Entering Air Temp	Discharge ±10 psig	Suction ± 5 psig
65° F	242	145
75° F	281	145
85° F	325	148
95° F	377	149
105° F	415	150
115° F	472	151

**TABLE 7 581066-01
036 NORMAL OPERATING PRESSURES**

Outdoor Coil Entering Air Temp	Discharge ±10 psig	Suction ± 5 psig
65° F	259	144
75° F	301	147
85° F	347	149
95° F	390	152
105° F	448	155
115° F	511	157

**TABLE 8 581067-01
048 NORMAL OPERATING PRESSURES**

Outdoor Coil Entering Air Temp	Discharge ±10 psig	Suction ± 5 psig
65° F	247	129
75° F	284	134
85° F	328	137
95° F	375	140
105° F	425	143
115° F	480	144

**TABLE 9 581068-01
060 NORMAL OPERATING PRESSURES**

Outdoor Coil Entering Air Temp	Discharge ±10 psig	Suction ± 5 psig
65° F	259	139
75° F	299	140
85° F	343	141
95° F	391	143
105° F	444	146
115° F	506	148

**TABLE 10
SUBCOOLING TEMPERATURE**

Unit	Liquid Saturated Temp. Minus Liquid Temperature
024	7.4°F ± 1 (4.1°C ± 0.5)
036	7.6°F ± 1 (4.2°C ± 0.5)
048	5.7°F ± 1 (3.2°C ± 0.5)
060	6.8°F ± 1 (3.8°C ± 0.5)

V- SYSTEMS SERVICE CHECKS

A-Heating System Service Checks

All LDT units are C.S.A. design certified without modification.

Before checking piping, check with gas company or authorities having jurisdiction for local code requirements. Refer to the LDT Installation instruction for more information.

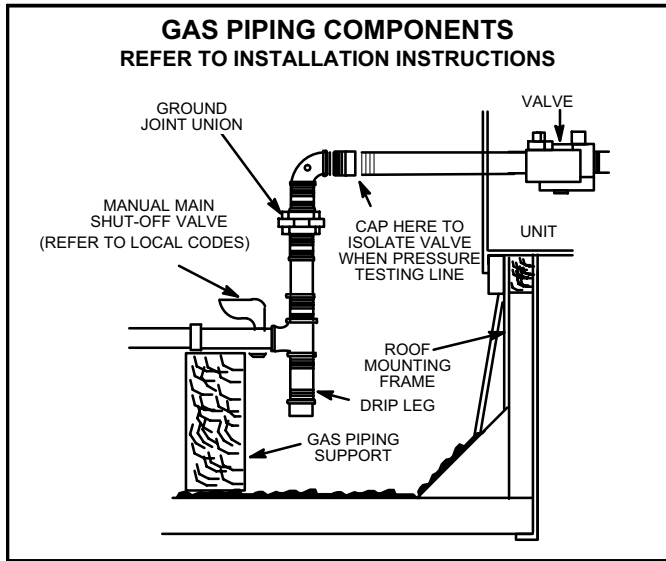

FIGURE 21

1-Gas Piping

Gas supply piping must not allow more than 0.5"W.C. (124.3 Pa) drop in pressure between the gas meter and the unit. Supply gas pipe must not be smaller than the unit gas connection. Refer to installation instructions for details.

2-Testing Gas Piping

NOTE-In case shutdown is required, turn off the main manual shut-off valve and disconnect the main power to the unit. These controls should be properly labeled by the installer.

When pressure testing gas lines, the gas valve must be disconnected and isolated. **Gas valves can be damaged if subjected to more than 0.5 psig [14"W.C. (3481 Pa)].** See figure 22.

When checking piping connection for gas leaks, use the preferred means. Common kitchen detergents can cause harmful corrosion on various metals used in gas piping. The use of specialty Gas Leak Detector is strongly recommended.

Do not use matches, candles, flame or any other source of ignition to check for gas leaks.

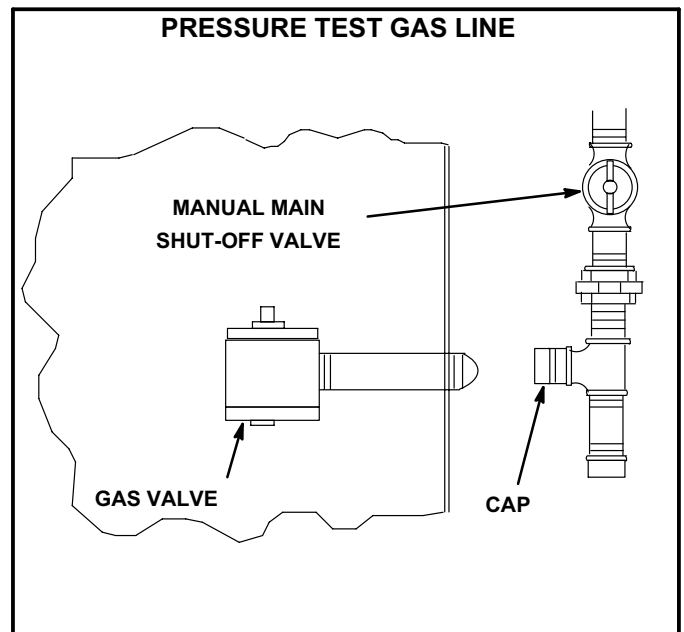

FIGURE 22

3-Testing Gas Supply Pressure

When testing gas supply pressure, connect test gauge to the inlet pressure tap located on unit gas valve GV1. Test supply gas pressure with unit firing at maximum rate (both stages energized). Make sure the reading falls within the range of the following values. Low pressure may result in erratic operation or "under fire." High pressure can result in permanent damage to the gas valve or "over fire." For natural gas units, operating pressure at the unit gas connection must be between 4.5"W.C. and 10.5"W.C. For L.P. gas units, operating pressure at the unit gas connection must be between 10.5"W.C. and 13.0"W.C.

On multiple unit installations, each unit should be checked separately while operating at maximum rate, beginning with the one closest to the supply gas main and progressing to the one furthest from the main. Multiple units should also be tested with and without the other units operating. Supply pressure must fall within the range listed in the previous paragraph.

4-Check and Adjust Manifold Pressure

After line pressure has been checked and adjusted, check manifold pressure. Move test gauge to the outlet pressure tap located on unit gas valve GV1. See figure 20 for location of pressure tap on the gas valve.

The manifold pressure is factory set and should not require adjustment. See table 3. If manifold pressure is incorrect and no other source of improper manifold pressure can be found, the valve must be replaced. See figure 20 for location of gas valve (manifold pressure) adjustment screw.

All gas valves are factory regulated. The gas valve should completely and immediately cycle off in the event of gas or power failure. The manual shut-off knob/switch can be used to immediately shut off gas supply.

⚠ CAUTION

For safety, connect a shut-off valve between the manometer and the gas tap to permit shut off of gas pressure to the manometer.

Manifold Adjustment Procedure

- 1- Connect test gauge to the outlet pressure tap on the gas valve. Start the unit (call for second stage heat) and allow five minutes for the unit to reach steady state.
- 2- While waiting for the unit to stabilize, notice the flame. The flame should be stable without flashback and should not lift from the burner heads. Natural gas should burn basically blue with some clear streaks. L.P. gas should burn mostly blue with some clear yellow streaks.
- 3- After allowing the unit to stabilize for five minutes, record the manifold pressure and compare to the values given in table 3. On two-stage units, check low fire, make adjustments, and recheck high fire before recording values.

Combustion gases

Flue products must be analyzed and compared to the unit specifications. Problems detected during the inspection may make it necessary to temporarily shut down the furnace until the items can be repaired or replaced.

5-Proper Gas Flow

Furnace should operate at least 5 minutes before checking gas flow. Determine time in seconds for two revolutions of gas through the meter. (Two revolutions assures a more accurate time.) Divide by two and compare to time in table 11. Seconds in table 11 are based on a 1 ft.³ dial and gas value of 1000 Btu/ft³ for natural and 2500 Btu/ft³ for LP. Adjust manifold pressure on gas valve to match time needed.

NOTE - To obtain accurate reading, shut off all other gas appliances connected to meter.

TABLE 11

Unit Input Rate	Seconds for Natural	Seconds for Propane
65,000	55	138
105,000	34	86
150,000	24	60

⚠ IMPORTANT

Disconnect heating demand as soon as an accurate reading has been obtained.

6-Heat Exchanger

To Access or Remove Heat Exchanger From Unit:

- 1- Turn off gas and electric power.

- 2- Remove access panel(s) and unit center mullion.
- 3- Remove gas valve, manifold assembly and burners.
- 4- Remove combustion air inducer. Pay careful attention to the order in which gaskets and orifice are removed.
- 5- Support heat exchanger (to prevent it from falling when final screws are removed.)
- 6- Remove screws supporting heat exchanger.
- 7- To install heat exchanger, reverse procedure. Be sure to secure all wires and check plumbing and burner plate for airtight seal. Screws must be torqued to 35 in.-lbs. to ensure proper operation.

7-Flame Sensing

Flame current is an electrical current which passes from the ignition control through the sensor electrode during unit operation. The current passes from the sensor through the flame to the ground electrode (located on the flame electrode) to complete a safety circuit. The electrodes should be located so the tips are at least 1/2" (12.7 mm) inside the flame envelope. Do not bend electrodes. To measure flame current, follow the procedure on the following page:

NOTE-Electrodes are not field adjustable. Any alterations to the electrode may create a hazardous condition that can cause property or personal injury.

- 1- Disconnect power to unit.
- 2- Remove lead from sensing electrode and install a 0-50DC microamp meter in series between the sensing electrode and the sensing lead.
- 3- Reconnect power and adjust thermostat for heating demand.
- 4- When flame is established, microamp reading should be 0.5 to 1.0. Do not bend electrodes. *Drop out signal is .09 or less.*
- 5- Disconnect power to unit before disconnecting meter. Make sure sensor wire is securely reconnected before reconnecting power to unit.

NOTE-If the meter scale reads 0, the leads are reversed. Disconnect power and reconnect leads for proper polarity.

B-Cooling System Service Checks

LDT units are factory charged and require no further adjustment; however, charge should be checked periodically using the approach method. The approach method compares actual liquid temperature with the outdoor ambient temperature. See section IV- CHARGING.

NOTE-When unit is properly charged discharge line pressures should approximate those in tables 6 through 9.

VI-MAINTENANCE

The unit should be inspected once a year by a qualified service technician.

⚠ WARNING



Electric shock hazard. Can cause injury or death. Before attempting to perform any service or maintenance, turn the electrical power to unit OFF at disconnect switch(es). Unit may have multiple power supplies.

⚠ CAUTION

Label all wires prior to disconnection when servicing controls. Wiring errors can cause improper and dangerous operation. Verify proper operation after servicing.

⚠ WARNING

This product contains a chemical known to the State of California to cause cancer, birth defects, or other reproductive harm.

A-Filters

Units are equipped with temporary filters which must be replaced prior to building occupation. See figure 23. All units have 20 X 20 X 2 in. (508 X 508 X 51mm) filters. Refer to local codes or appropriate jurisdiction for approved filters.

NOTE-Filters must be U.L.C. certified or equivalent for use in Canada.

B-Lubrication

All motors are lubricated at the factory. No further lubrication is required.

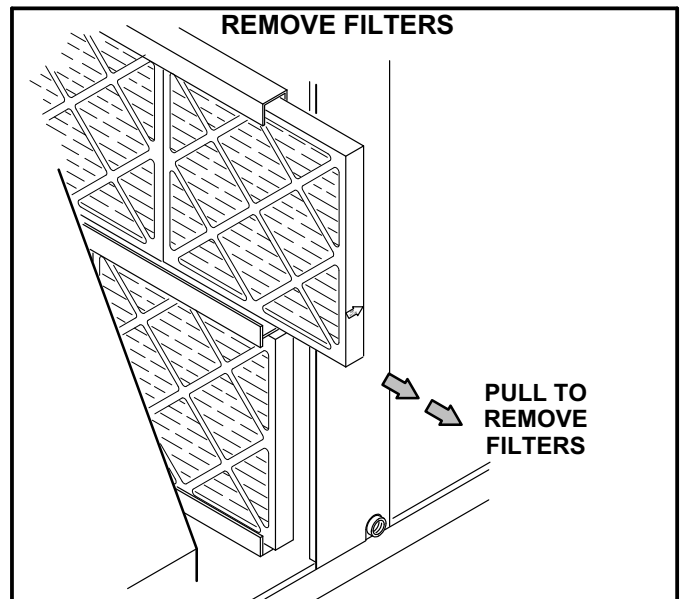

FIGURE 23

C-Burners

Periodically examine burner flames for proper appearance during the heating season. Before each heating season examine the burners for any deposits or blockage which may have occurred.

Clean burners as follows:

- 1- Turn off both electrical power and gas supply to unit.
- 2- Remove burner compartment access panel.
- 3- Remove top burner box panel.
- 4- Remove two screws securing burners to burner support and lift the burners from the orifices. See figure 14. Clean as necessary.

⚠ WARNING



Danger of explosion. Can cause injury or death. Do not overtighten main burner mounting screws. Snug tighten only.

D-Combustion Air Inducer

A combustion air proving switch checks combustion air inducer operation before allowing power to the gas controller. Gas controller will not operate if inducer is obstructed.

Under normal operating conditions, the combustion air inducer wheel should be checked and cleaned prior to the heating season. However, it should be examined periodically during the heating season to establish an ideal cleaning schedule.

Clean combustion air inducer as follows:

- 1- Shut off power supply and gas to unit.
- 2- Remove the mullion on the right side of the heat section.
- 3- Disconnect pressure switch air tubing from combustion air inducer port.
- 4- Remove and retain screws securing combustion air inducer to flue box. Remove vent connector. See figure 13.
- 5- Clean inducer wheel blades with a small brush and wipe off any dust from housing. Take care not to damage exposed fan blades. Clean accumulated dust from front of flue box cover.
- 6- Return combustion air inducer motor and vent connector to original location and secure with retained screws. It is recommended that gaskets be replaced during reassembly.
- 7- Replace mullion.
- 8- Clean combustion air inlet louvers on heat access panel using a small brush.

E-Flue Passageway and Flue Box

Remove flue box cover only when necessary for equipment repair. Clean inside of flue box cover and heat exchanger tubes with a wire brush when flue box cover has to be removed. Install a new flue box cover gasket and replace cover. Make sure edges around flue box cover are tightly sealed.

F-Evaporator Coil

Inspect and clean coil at beginning of each cooling season. Clean using mild detergent or commercial coil cleanser. Flush coil and condensate drain with water taking care not to get insulation, filters and return air ducts wet.

G-Condenser Coil

Clean condenser coil annually with detergent or commercial coil cleaner and inspect monthly during the cooling season.

Condenser coils are made of single and two formed slabs. On units with two slabs, dirt and debris may become trapped between the slabs. To clean between slabs, carefully separate coil slabs and wash them thoroughly. See figure 24. Flush coils with water following cleaning.

Note - Remove all screws and gaskets prior to cleaning procedure and replace upon completion.

H-Supply Blower Wheel

Annually inspect supply air blower wheel for accumulated dirt or dust. Turn off power before attempting to remove access panel or to clean blower wheel.

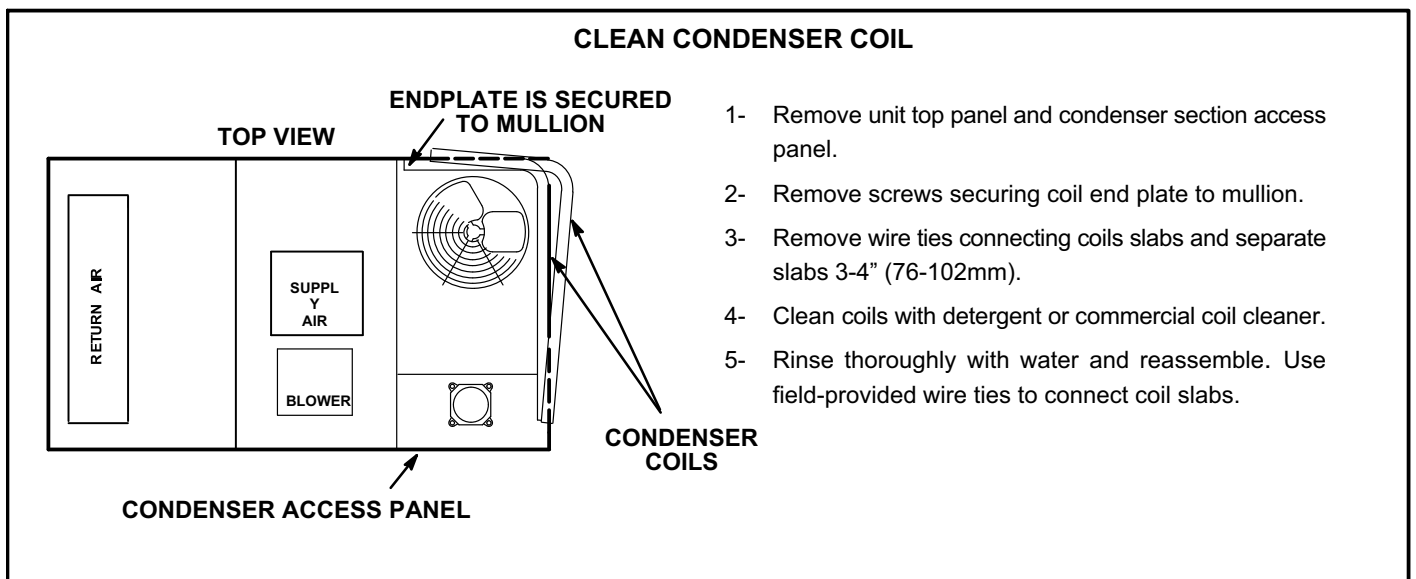

FIGURE 24

VII-ACCESSORIES

The accessories section describes the application of most of the optional accessories which can be factory- or field-installed to the LDT units.

A-C1/T1CURB

When installing the LDT units on a combustible surface for downflow discharge applications, the C1/T1CURB 8 inch, 14-inch, 18 inch or 24-inch height roof mounting frame is used. The roof mounting frames are recommended in all other applications but not required. If the LDT units are not mounted on a flat (roof) surface, they **MUST** be supported under all edges and under the middle of the unit to prevent sagging. The units **MUST** be mounted level within 1/16" per linear foot or 5mm per meter in any direction.

The assembled mounting frame is shown in figure 25. Refer to the roof mounting frame installation instructions for details of proper assembly and mounting. The roof mounting frame **MUST** be squared to the roof and level before mounting. Plenum system **MUST** be installed before the unit is set on the mounting frame. Typical roof curbing and flashing is shown in figure 26. Refer to the roof mounting frame installation instructions for proper plenum construction and attachment.

B-Transitions

Optional supply/return transitions are available for use with the LDT 2, 3, 4, and 5 ton units (refer to EHB for appropriate transition model). Transition must be installed in the C1/T1CURB mounting frame before mounting the unit to the frame. Refer to the manufacturer's instructions included with the transition for detailed installation procedures.

C-Outdoor Air Dampers Figures 27 and 28

Optional outdoor air dampers are available for use with the LDT 2, 3, 4, and 5 ton units in both manually operated (figure 27) and motorized (figure 28) options (refer to EHB for appropriate transition model). Both sets include the outdoor air hood. The manual damper is set at a fixed point to bring outside air into the building anytime the blower is operating. The motorized damper opens when the blower is operating and the thermostat is sending an occupied signal to the Unit Controller. If the thermostat signal is unoccupied, the motorized damper will not open. Washable filter supplied with the outdoor air dampers can be cleaned with water and a mild detergent. It should be sprayed with Filter Handicoater when dry prior to re-installation. Filter Handicoater is R.P. Products coating no. 418 and is available as Part No. P-8-5069.

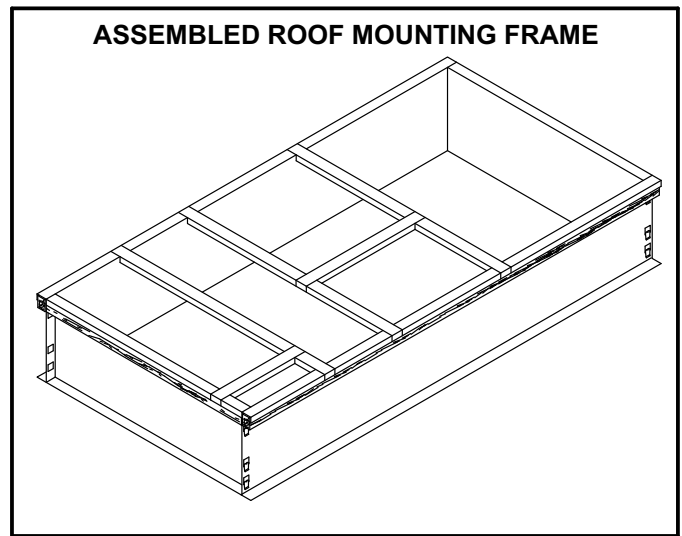

FIGURE 25

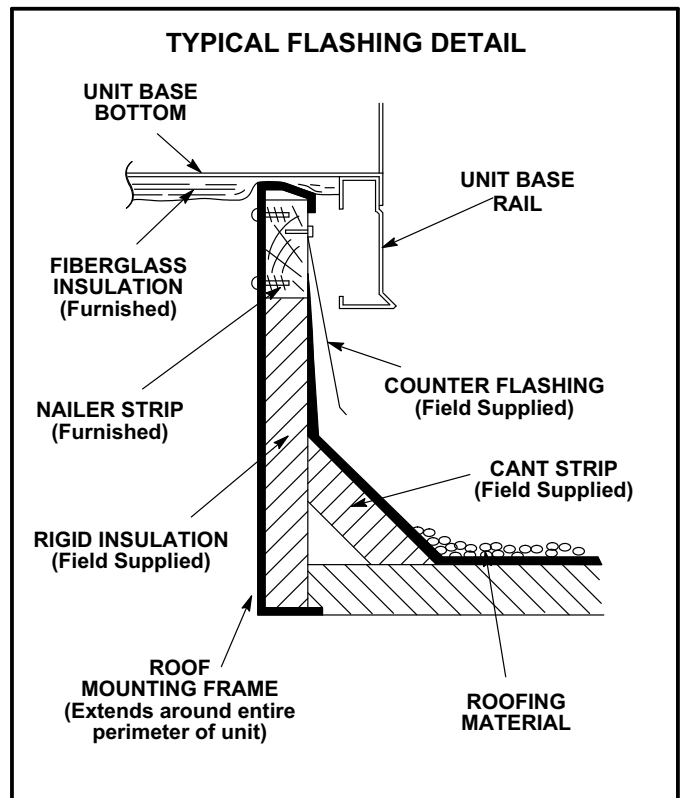

FIGURE 26

MANUAL OUTDOOR AIR DAMPER

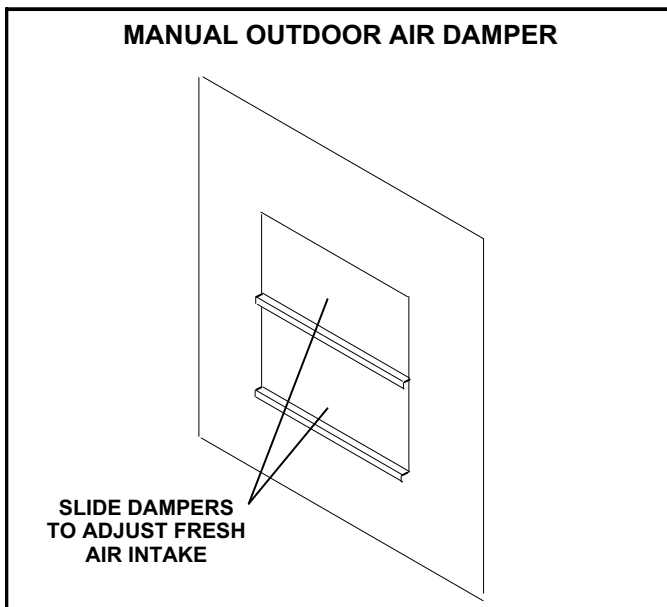

FIGURE 27

MOTORIZED OUTDOOR AIR DAMPER

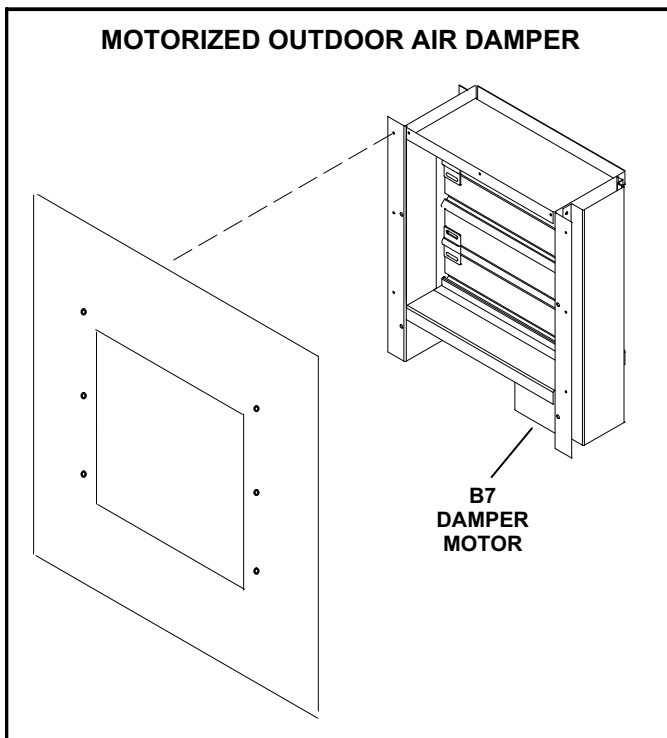

FIGURE 28

D-Supply and Return Diffusers

Optional flush mount diffuser/return FD9-65 and FD11-95 and extended mount diffuser/return RTD9-65 and RTD11-95 are available for use with all LDT units. Refer to manufacturer's instructions included with transition for detailed installation procedures.

E-Economizer (Optional Field- or Factory-Installed)

The economizer uses outdoor air for free cooling when temperature is suitable. See figure 29.

When outdoor air is suitable, the Unit Controller will modulate the economizer dampers to maintain 55°F discharge air (RT6). Refer to unit controller manual for menu paths to adjust economizer setpoints.

Sensors

Units are equipped with the following factory-installed, CEC Title 24 approved sensors:

- RT17 - Outside Air Temperature
- RT16 - Return Air Temperature
- RT6 - Discharge Air Temperature

See figure 30 for sensor location.

Optional field-provided sensors may be used instead of unit sensors to determine whether outdoor air is suitable for free cooling. Refer to table 12. TEMP OFFSET is the default mode.

Note - Network OAS signal and California Title 24 Compliance options use either TEMPERATURE OFFSET or TEMPERATURE SETPT mode.

Minimum Position

The Unit Controller will move the dampers to minimum position during the following:

- Ventilation mode (G demand only)
- Outdoor air is NOT suitable for free cooling

The damper position will vary linearly with blower speed based on the damper position settings for high and low CFM. Damper calibration must be initiated in the mobile service app to set high and low damper positions.

GED (Gravity Exhaust / Barometric Relief Dampers) Field-Installed Option

The GED is located in the economizer except in downflow applications or when a PEF (power exhaust fan) is NOT installed. In horizontal airflow applications or when a PEF is installed, the GED is located in the exhaust air hood.

Horizontal Air Discharge Economizers

The economizer is located in the unit the same as down-flow applications but note the position of the return air duct. The duct attaches to a duct transition and duct inlet on the end of the unit. An optional GED is located in the duct transition. See figure 31.

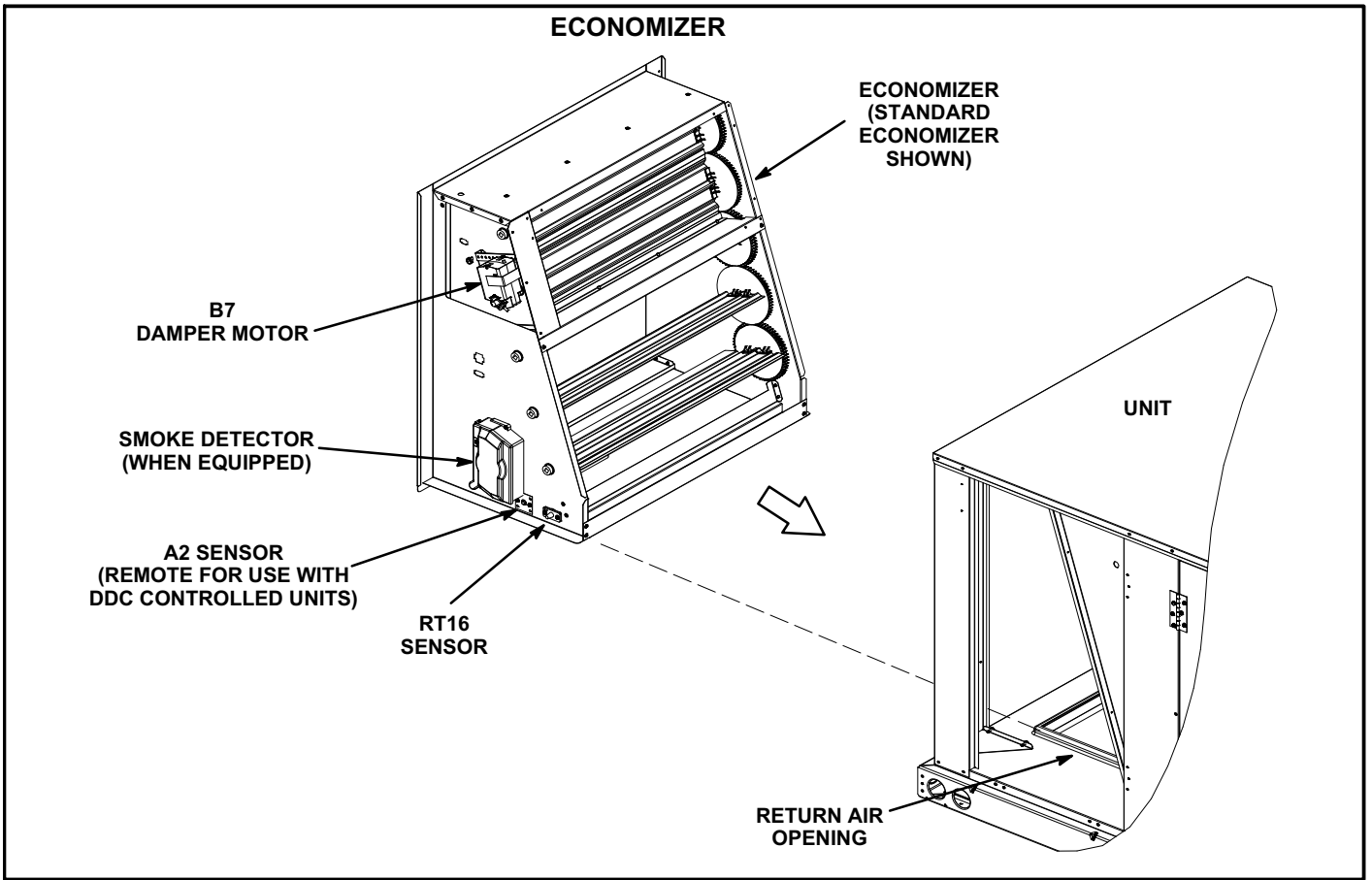

FIGURE 29

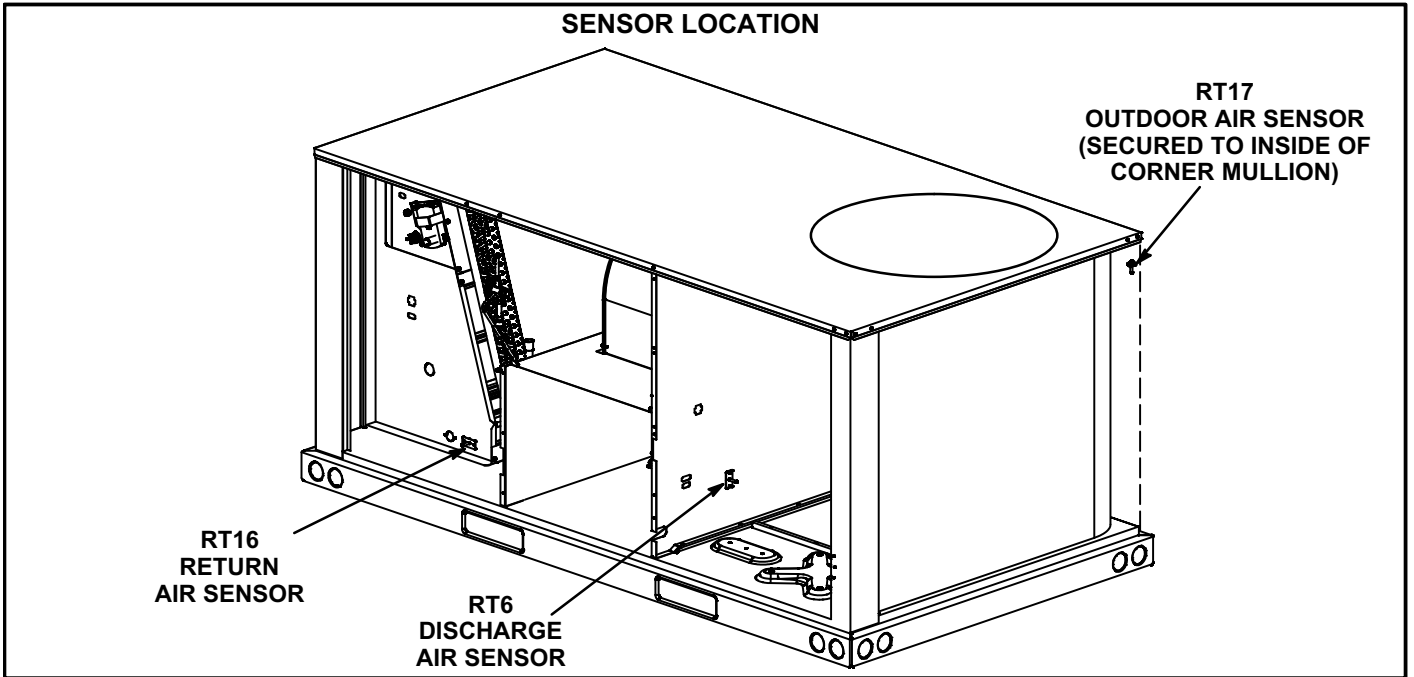

FIGURE 30

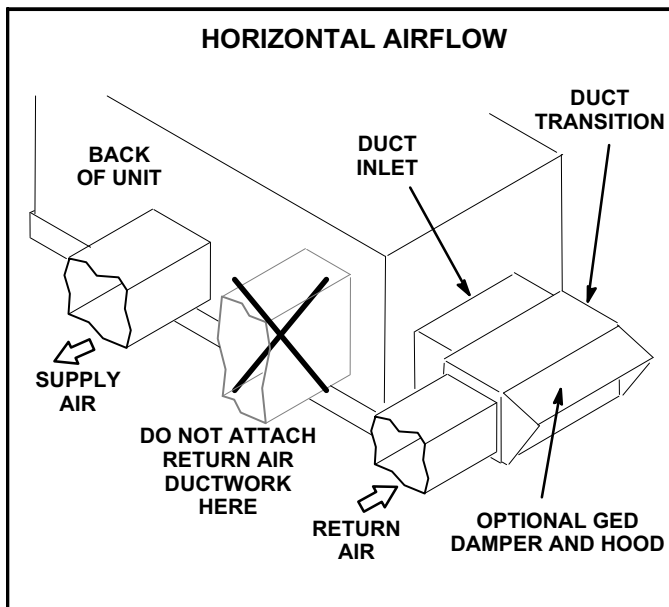

FIGURE 31

TABLE 12
ECONOMIZER MODES AND SETPOINT

Free Cooling Mode	Free Cooling Setpoint	Field-Provided Sensors	Dampers will modulate to 55°F discharge air (RT6) when outdoor air is suitable:	Permitted Inputs
TEMP	OFFSET	None Needed	Outdoor air temperature (RT17) is less than return air temperature (RT16) by at least the OFFSET value.	0-40°F
TEMP	OAT STPT	None Needed	Outdoor air temperature (RT17) is less than the OAT STPT value.	41-75°F
Remote	Remote	Energy Management System**	Either of the TEMP modes can be used when a network OAS signal is provided by an energy management or building control system, via BACnet, LonTalk, or L Connection. The network can command OAS, NOT OAS, or AUTO. AUTO returns to local control of OAS, which is the selected TEMP mode.	NA
ENTH	DIFF OFFSET	(Two) C7400	Outdoor air enthalpy* (A7) is less than return air enthalpy (A62) by at least the OFFSET value.	0mA-4mA
ENTH	ODE STPT	C7400	Outdoor air enthalpy (A7) is less than free cooling setpoint.	12-19mA
GLOBAL	GLOBAL	24VAC Input Signal	Global input is energized by (P297-9). This setting is also used for outdoor air damper applications. Global input also brings on the blower. (This mode is NOT used when OAS signal is provided via network connection. GLO is only used when a 24VAC signal is used to energize the P297-9 GLO input.)	NA

*Enthalpy includes effects of both temperature and humidity.

**Energy management systems may require additional field-provided sensors; refer to manufacturer's instructions.

Outdoor Air Damper and Economizer Operation

Note: Direct drive units feature ECM condenser fans that are staged to match the compressor's capacity..

Modulating Outdoor Air Damper:

Damper minimum positions #1 and 2 are adjusted during unit setup to provide minimum fresh air requirements at the indicated supply fan speeds per ASHRAE 62.1.

- Supply fan is off and the outdoor air damper is closed
- Supply fan is on low speed and the outdoor air damper is at minimum position 1
- Supply fan is on high speed and the outdoor air damper is at minimum position 2

¹Outdoor Air is Suitable

Note: When outdoor air is not suitable during the occupied time period, damper modulates to minimum position. When outdoor air is not suitable during the unoccupied time period, damper modulates closed.

1-Economizer With Outdoor Air Suitable

- Low Cooling Demand -
 - Compressor Off
 - Blower Low
 - Dampers Modulate
- High Cooling Demand -
 - Compressor Low (036, 048, 060 only)
 - Compressor On (024 only)
 - Blower High
 - Dampers Full Open

Note - Compressor is energized after damper has been at full open for three minutes.

Note - Free cooling is locked out when a dehumidification demand is received. The unit operates in dehumidification mode as if the outdoor air is not suitable.

2-No Economizer or Outdoor Air Not Suitable

- Low Demand -
 - Compressor Low (036, 048, 060 only)
 - Compressor On (024 only)
 - Blower Low
 - Damper Minimum Position
- High Demand -
 - Compressor High (036, 048, 060 only)
 - Compressor On (024 only)
 - Blower High
 - Damper Minimum Position

F-Power Exhaust Relay K65 (power exhaust units)

Power exhaust relay K65 is a DPDT relay with a 24VAC coil. K65 is used in all LDT units equipped with the optional power exhaust dampers. K65 is energized by the Unit Controller after the economizer dampers reach 50% open (adjustable). When K65 closes, exhaust fan B10 is energized.

G-Power Exhaust Fans

Optional power exhaust fans are available for use with the LDT 2, 3, 4, and 5 ton units to provide exhaust air pressure relief (refer to EHB for appropriate transition model). See figure 32 and installation instructions for more detail.

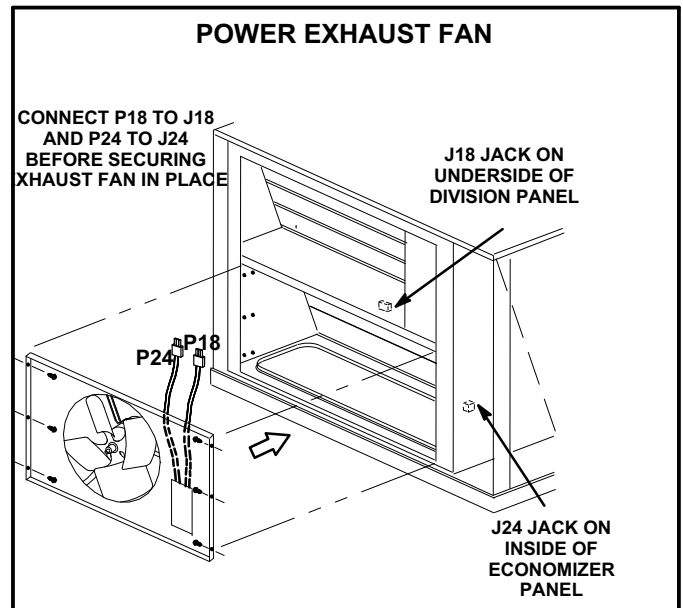

FIGURE 32

H-Optional UVC Lights

The germicidal light emits ultraviolet (UVC) energy that has been proven effective in reducing microbial life forms (viruses, bacteria, yeasts, and molds) in the air.

UVC germicidal lamps greatly reduce the growth and proliferation of mold and other bio-aerosols (bacteria and viruses) on illuminated surfaces.

Germicidal lamps are NOT intended to be used for removal of active mold growth. Existing mold growth must be appropriately removed PRIOR to installation of the germicidal lamp.

Refer closely to UVC light installation instruction warnings when servicing units.

J-Needlepoint Bipolar Ionizer (Optional)

The optional, brush-type ionizer produces positive and negative ions to clean air and reduce airborne contaminants. The ionizer was designed to be low maintenance. The device should be checked semi-annually to confirm the brushes are clean for maximum output. The ionizer is located behind on the blower deck to the left of the blower. See figure 34.

- 1- On the back side of the unit, remove the screw securing the back of the ionizer bracket. See figure 33. Retain the screw to secure the back side of the ionizer bracket.
- 2- Remove two screws securing the front side of the ionizer bracket and pull out of unit and clean brushes.
- 3- Replace ionizer in the reverse order it was removed.

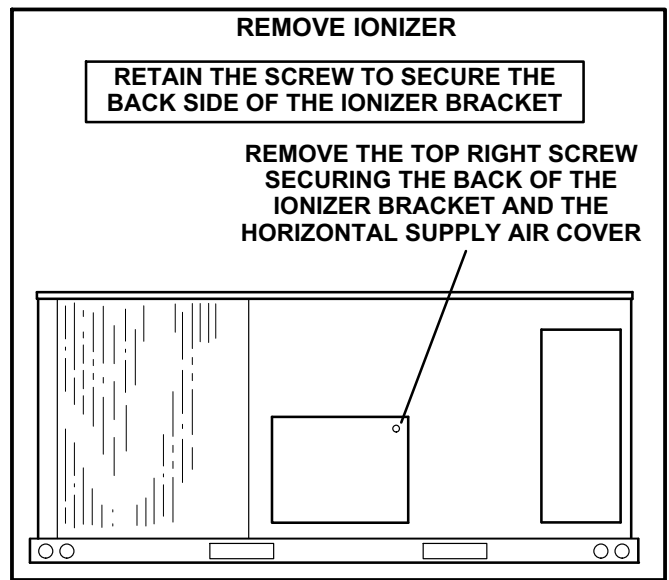

FIGURE 33

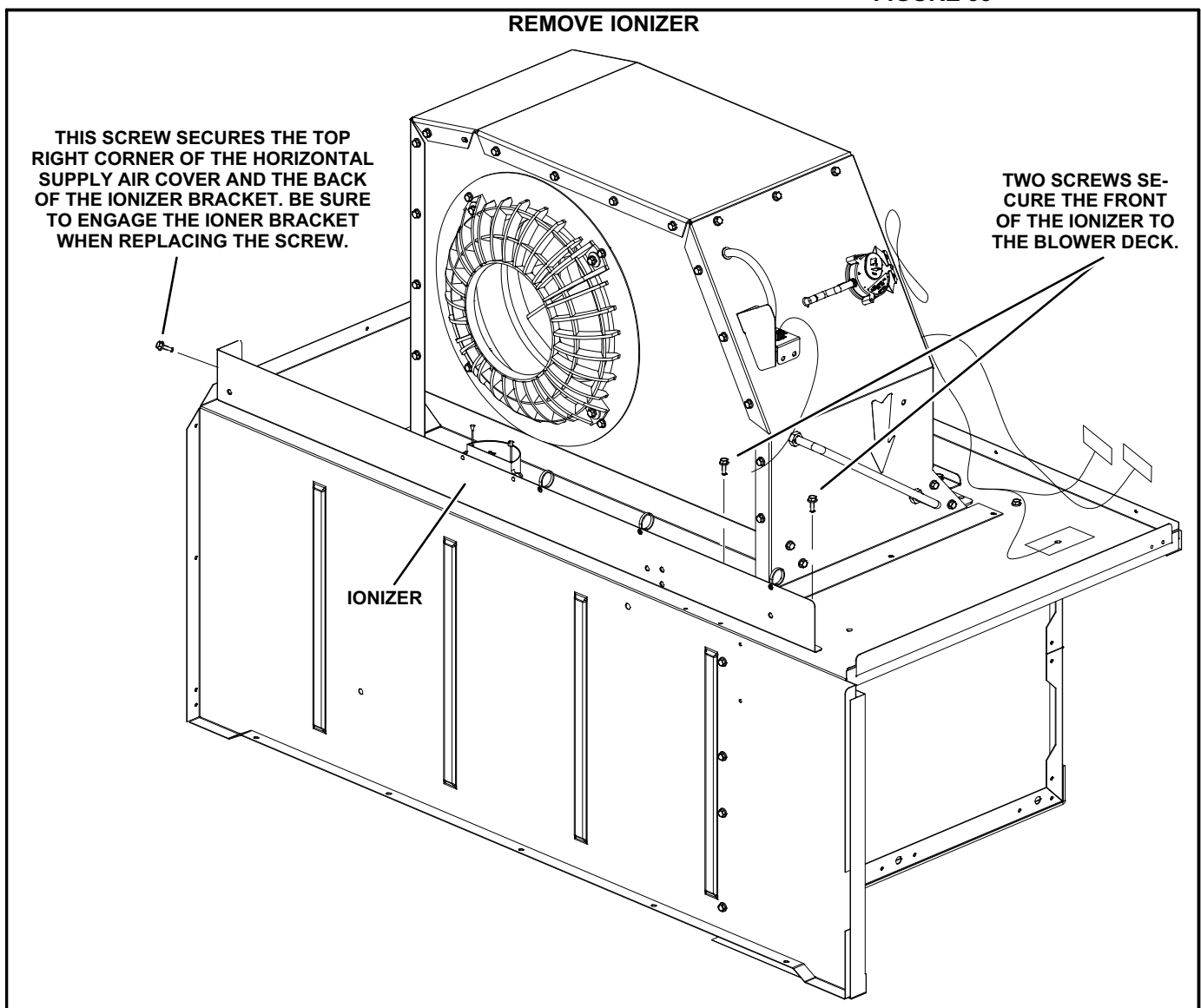

FIGURE 34

I-Optional Cold Weather Kit

An electric heater is available to automatically control the minimum temperature in the gas burner compartment. Heater is C.S.A. certified to allow cold weather operation of unit down to -60° F (-50° C).

The kit includes the following parts:

- 1- The strip heater (HR6) is located as close as possible to the gas valve. The strip heater is rated at 500 Watts
- 2- A thermostat mounting box is installed on the wall of the compressor compartment. Included in the box are the following thermostat switches:
 - a - Thermostat switch (S59) is an auto-reset SPST N.C. switch which opens on a temperature drop. The switch is wired in series with 24v power and the combustion air blower switch. When the temperature drops below -30° F (-35° C) the switch opens and the gas heat section is de-energized. The switch automatically resets when the heating compartment temperature reaches -10° F (-12° C).
 - b - Thermostat switch (S60) is an auto-reset SPST N.C. switch which opens on a temperature rise. The switch is wired in series with HR6. When the temperature rises above 20° F (-7° C) the switch opens and the electric heater is de-energized. The switch automatically resets when the heating compartment temperature reaches -10° F (23.3° C).
 - c -Thermostat switch (S61) is an auto-reset SPST N.O. switch which closes on a temperature drop. The switch is wired in series with HR6. When temperature drops below 20° F (-7° C) the switch closes and electric heater is energized. The switch automatically opens when heating compartment temperature reaches 70° F (21° C).

J-Smoke Detectors A171 and A172

Photoelectric smoke detectors are a factory- or field-installed option. The smoke detectors can be installed in the supply air duct (A172), return air section (A171), or in both the supply duct and return air section.

K-Indoor Air Quality (CO₂) Sensor A63

The indoor air quality sensor monitors CO₂ levels and reports the levels to the Unit Controller. The Unit Controller adjusts the economizer dampers according to the CO₂ levels. The sensor is mounted next to the indoor thermostat or in the return air duct. Refer to the indoor air quality sensor installation instructions for proper adjustment.

L-LP / Propane Kit

All units operated on LP/Propane require a natural to LP /propane kit. The kit for single-stage units include one LP spring, seven burner orifices, and three stickers. Two-stage kits include the same but has a prove switch used to lock out first stage on the combustion air inducer. Four-stage units require (2) two-stage kits. For more detail refer to the natural to LP gas changeover kit installation instructions.

M-Drain Pan Overflow Switch S149 (option)

The overflow switch is used to interrupt cooling operation when excessive condensate collects in the drain pan. The N.O. overflow switch is controlled by K220 and DL46 relays, located in the unit control panel. When the overflow switch closes, 24VAC power is interrupted and after a five-second delay unit compressors are de-energized. Once the condensate level drops below the set level, the switch will open. After a five-minute delay the compressor will be energized.

N-Dirty Filter Switch S27

The dirty filter switch senses static pressure increase indicating a dirty filter condition. The switch is N.O. and closes at 1" W.C. (248.6 Pa) The switch is mounted in the supply air section on the evaporator coil seal.

VIII-Wiring Diagrams and Sequence of Operation

036H / 060H G, J VOLT ECM MOTOR WITHOUT SCCR

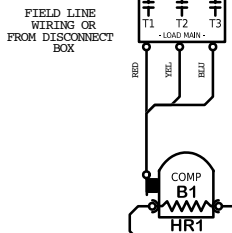
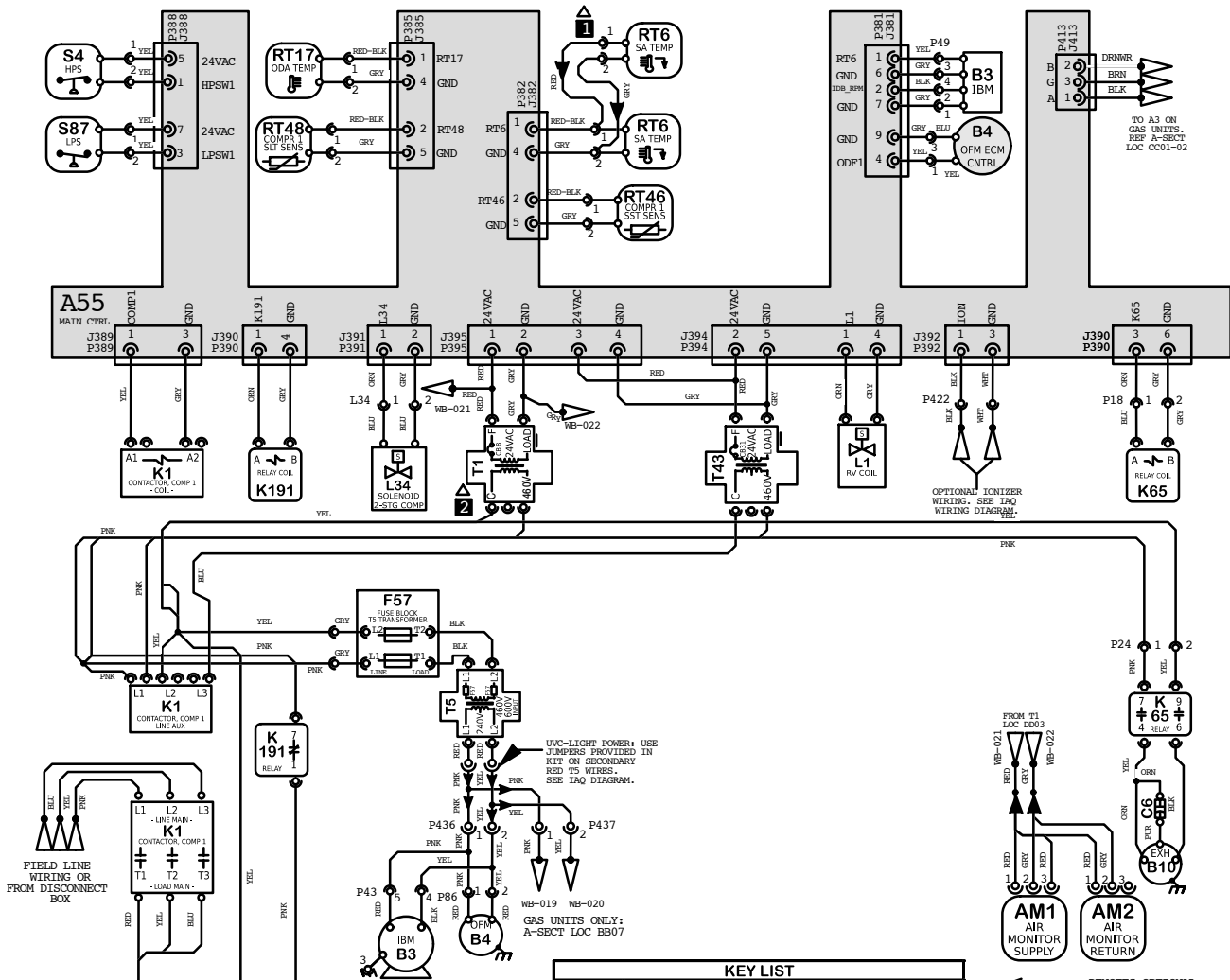

LOCATION	COMPONENT DESCRIPTION
AA01.02.03	A55 CONTROL BOARD, MAIN
HH07	AM1, AM2 AIR MONITOR, SUPPLY/RETURN, IAO-TVOC
BB08	B1 COMPRESSOR 1
GG01,CC07	B3 MOTOR, BLOWER
GG02,DD07	B4 MOTOR, OUTDOOR FAN 1
HH06	B10 MOTOR, EXHAUST FAN 1
HH05	C6 CAPACITOR, EXHAUST FAN 1
CC05	F57 FUSE, T5 TRANSFORMER PRIMARY
BB08	HR1 HEATER, COMPRESSOR 1
BB04.05.06	K1 CONTACTOR, COMPRESSOR 1
HH04.05	K65 RELAY, EXHAUST FAN 1
BB04.06	K191 RELAY, CRANKCASE HEATER 1
FF04	L1 VALVE, REVERSING 1
CC04	L34 VALVE, SOLENOID, 2 STG COMPRESSOR
EE01	RT6 SENSOR, A55 DISCHARGE (IMC)
CC01	RT17 SENSOR, OUTSIDE AIR TEMP
EE02	RT46 SENSOR, SAT. SUCT. TEMP, COMP 1
CC02	RT48 SENSOR, SAT. LIQUID TEMP, COMP 1
AA01	S4 LIMIT, HI PRESS. SWITCH, COMP 1
AA01	S87 SWITCH, LOW PRESS. COMP 1
DD04	T1 TRANSFORMER, CONTROL
DD05	T5 TRANSFORMER, MOTOR
EE04	T43 TRANSFORMER, REHEAT

NOTES	
1	RT6 REMOTE MOUNT WIRING
2	MOVE WIRES FROM 240 TO 208 TAP ON TRANSFORMER FOR 208 VOLT APPLICATIONS

← DENOTES OPTIONAL COMPONENTS AND WIRES

WARNING
DISCONNECT ALL POWER BEFORE SERVICING.
ELECTRIC SHOCK HAZARD, CAN CAUSE INJURY OR DEATH. UNIT MUST BE GROUNDED IN ACCORDANCE WITH NATIONAL AND LOCAL CODES.
FOR USE WITH COPPER CONDUCTORS ONLY, REFER TO UNIT RATING PLATE FOR MINIMUM CIRCUIT AMPACITY AND MAXIMUM OVERCURRENT PROTECTION SIZE.
IF ANY WIRE IN THIS APPLIANCE IS REPLACED, IT MUST BE REPLACED WITH WIRE OF LIKE SIZE, RATING AND INSULATION THICKNESS.

Model: LDT, LHT 036H - 060H G, J VOLT HEATPUMP - ECM BLOWER WITHOUT HIGHER SCCR
Voltage: 460V/3~60Hz (G), 575V/3~60Hz (J)
Supersedes N/A Form No 538196-01 Rev:0

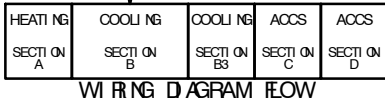

036H / 060H G, J VOLT ECM MOTOR WITH SCCR

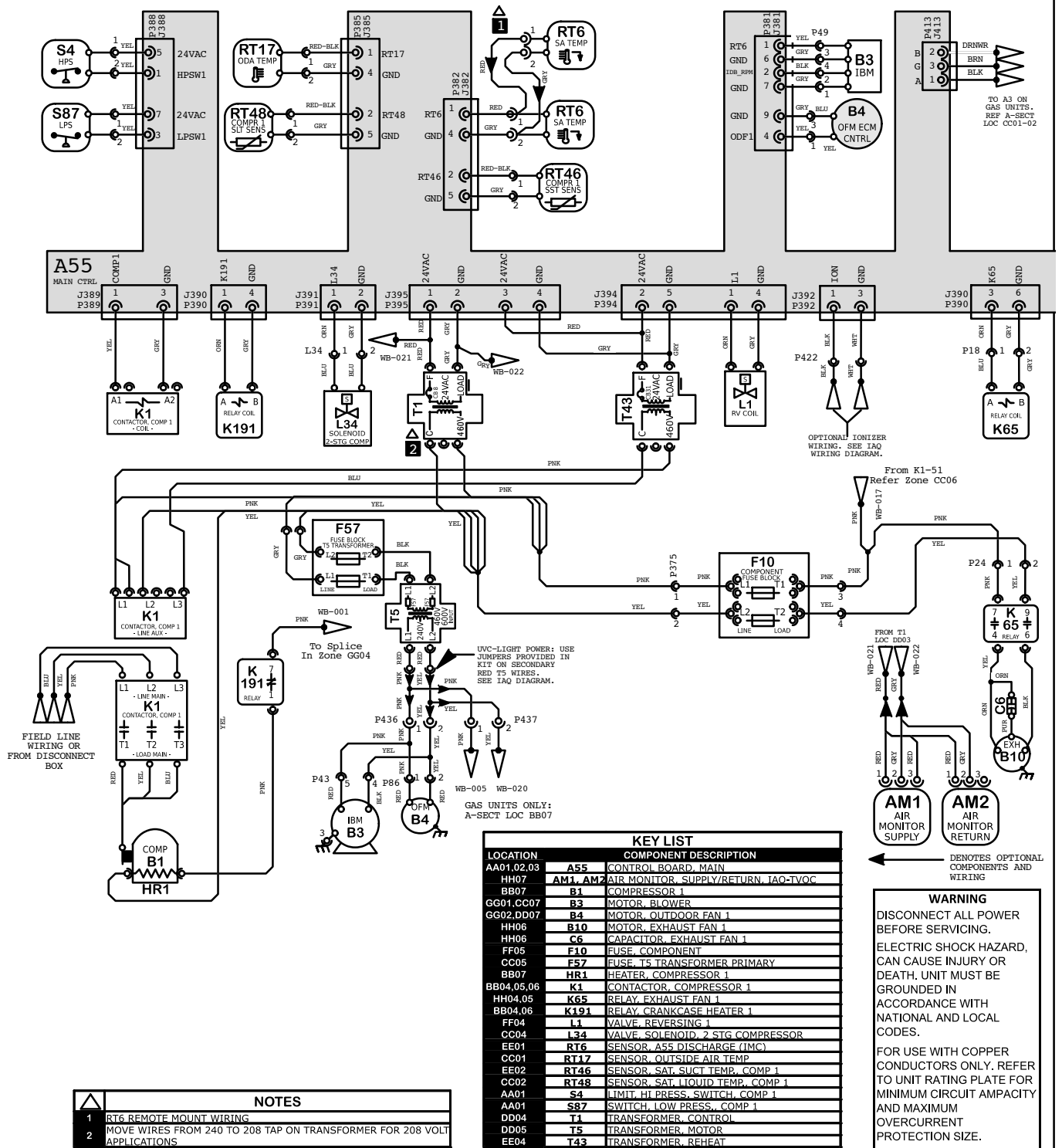

Model: LDT, LHT 036H - 060H G, J VOLT
 HEATPUMP - ECM BLOWER WITH HIGHER SCCR
 Voltage: 460V/3~/60Hz (G), 575V/3~/60Hz (J)
 Supersedes:N/A Form No:538197-01 Rev:0

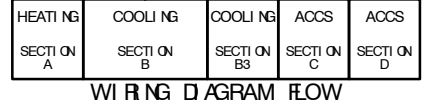

LOCATION	COMPONENT DESCRIPTION
AA01,02,03	A55 CONTROL BOARD, MAIN
HH07	AM1, AM2 AIR MONITOR, SUPPLY/RETURN, IAQ-TVOC
BB07	B1 COMPRESSOR 1
GG04,CC07	B3 MOTOR, BLOWER
GG02,DD07	B4 MOTOR, OUTDOOR FAN 1
HH06	B10 MOTOR, EXHAUST FAN 1
HH06	C6 CAPACITOR, EXHAUST FAN 1
FF05	F10 FUSE, COMPONENT
CC05	F57 FUSE, T5 TRANSFORMER PRIMARY
BB07	HR1 HEATER, COMPRESSOR 1
BB04,05,06	K1 CONTACTOR, COMPRESSOR 1
HH04,05	K65 RELAY, EXHAUST FAN 1
BB04,06	K191 RELAY, CRANKCASE HEATER 1
FF04	L1 VALVE, REVERSING 1
CC04	L34 VALVE, SOLENOID, 2 STG COMPRESSOR
EE01	RT6 SENSOR, A55 DISCHARGE (IMC)
CC01	RT17 SENSOR, OUTSIDE AIR TEMP
EE02	RT46 SENSOR, SAT. SUCT. TEMP, COMP 1
CC02	RT48 SENSOR, SAT. LIQUID TEMP, COMP 1
AA01	S4 LIMIT, HI PRESS. SWITCH, COMP 1
AA01	S87 SWITCH, LOW PRESS., COMP 1
DD04	T1 TRANSFORMER, CONTROL
DD05	T5 TRANSFORMER, MOTOR
EE04	T43 TRANSFORMER, REHEAT

NOTES	
1	RT6 REMOTE MOUNT WIRING
2	MOVE WIRES FROM 240 TO 208 TAP ON TRANSFORMER FOR 208 VOLT APPLICATIONS

WARNING

DISCONNECT ALL POWER BEFORE SERVICING. ELECTRIC SHOCK HAZARD, CAN CAUSE INJURY OR DEATH. UNIT MUST BE GROUNDED IN ACCORDANCE WITH NATIONAL AND LOCAL CODES.

FOR USE WITH COPPER CONDUCTORS ONLY. REFER TO UNIT RATING PLATE FOR MINIMUM CIRCUIT AMPACITY AND MAXIMUM OVERCURRENT PROTECTION SIZE.

IF ANY WIRE IN THIS APPLIANCE IS REPLACED, IT MUST BE REPLACED WITH WIRE OF LIKE SIZE, RATING AND INSULATION THICKNESS.

048H / 060H G VOLT EBM MOTOR WITHOUT SCCR

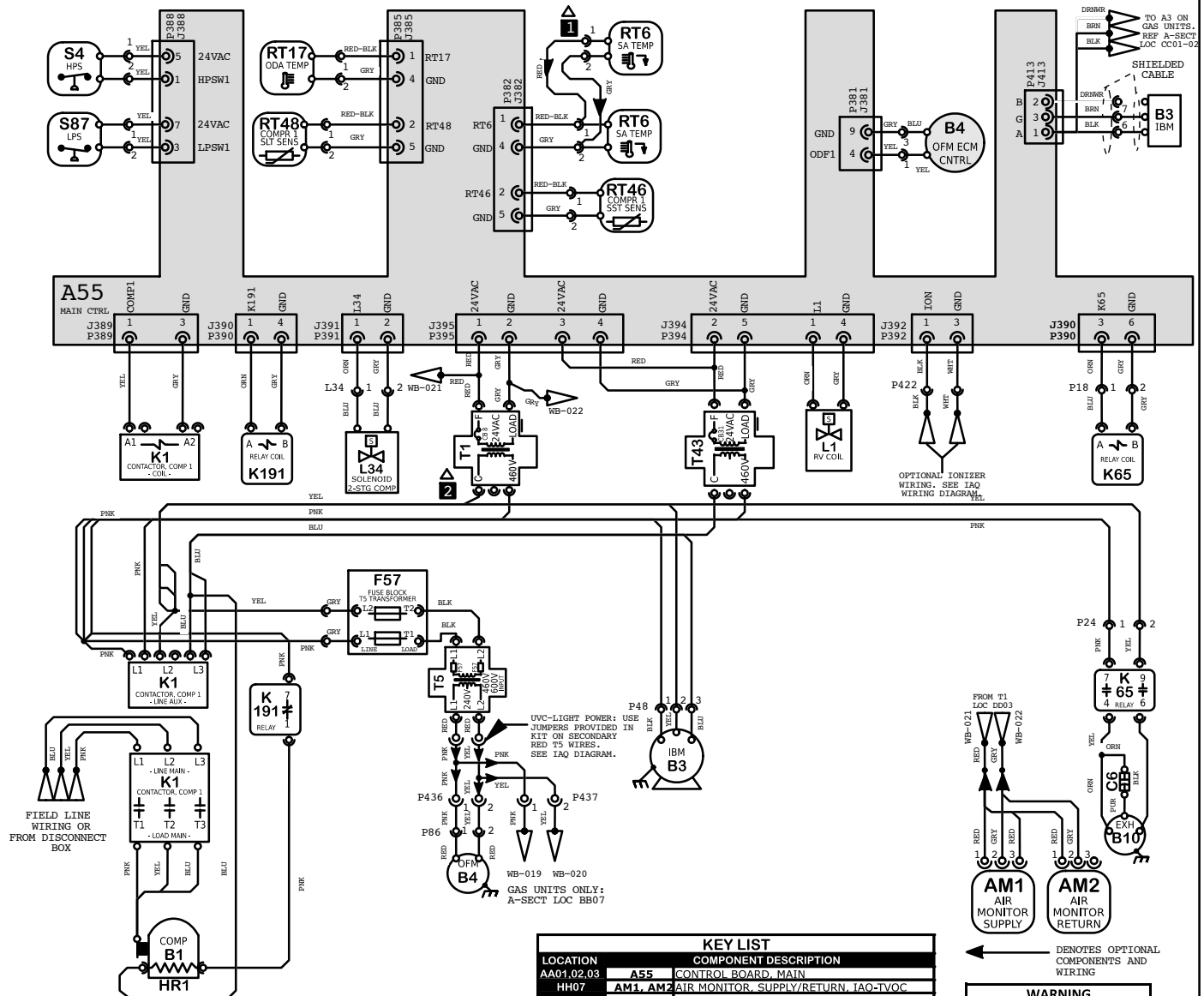

KEY LIST	
LOCATION	COMPONENT DESCRIPTION
AA01.02.03	A55 CONTROL BOARD, MAIN
HH07	AM1, AM2 AIR MONITOR, SUPPLY/RETURN, IAQ-TVOC
BB07	B1 COMPRESSOR 1
HH04.EE06	B3 MOTOR, BLOWER
GG02.DD07	B4 MOTOR, OUTDOOR FAN 1
HH06	B10 MOTOR, EXHAUST FAN 1
HH06	C6 CAPACITOR, EXHAUST FAN 1
CC05	F57 FUSE, T5 TRANSFORMER PRIMARY
BB07	HR1 HEATER, COMPRESSOR 1
BB04.05.06	K1 CONTACTOR, COMPRESSOR 1
HH04.05	K65 RELAY, EXHAUST FAN 1
BB04.06	K191 RELAY, CRANKCASE HEATER 1
FF04	L1 VALVE, REVERSING 1
CC04	L34 VALVE, SOLENOID, 2 STG COMPRESSOR
EE01	RT6 SENSOR, A55 DISCHARGE (IMC)
CC01	RT17 SENSOR, OUTSIDE AIR TEMP
EE02	RT46 SENSOR, SAT. SUCT TEMP, COMP 1
CC02	RT48 SENSOR, SAT. LIQUID TEMP, COMP 1
AA01	S4 LIMIT HI PRESS. SWITCH, COMP 1
AA01	S87 SWITCH, LOW PRESS., COMP 1
DD04	T1 TRANSFORMER, CONTROL
DD05	T5 TRANSFORMER, MOTOR
EE04	T43 TRANSFORMER, REHEAT

NOTES	
1	RT6 REMOTE MOUNT WIRING
2	MOVE WIRES FROM 240 TO 208 TAP ON TRANSFORMER FOR 208 VOLT APPLICATIONS

Model: LDT, LHT 048H - 060H G VOLT
 HEATPUMP - EBM BLOWER WITHOUT HIGHER SCCR
 Voltage: 460V/3-60Hz (G)
 Supersedes: N/A Form No: 538200-01 Rev: 0

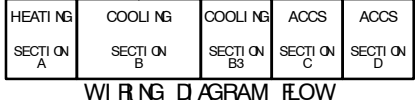

← DENOTES OPTIONAL COMPONENTS AND WIRING

WARNING
 DISCONNECT ALL POWER BEFORE SERVICING.
 ELECTRIC SHOCK HAZARD, CAN CAUSE INJURY OR DEATH. UNIT MUST BE GROUNDED IN ACCORDANCE WITH NATIONAL AND LOCAL CODES.
 FOR USE WITH COPPER CONDUCTORS ONLY. REFER TO UNIT RATING PLATE FOR MINIMUM CIRCUIT AMPACITY AND MAXIMUM OVERCURRENT PROTECTION SIZE.
 IF ANY WIRE IN THIS APPLIANCE IS REPLACED, IT MUST BE REPLACED WITH WIRE OF LIKE SIZE, RATING AND INSULATION THICKNESS.

048H / 060H G VOLT EBM MOTOR WITH SCCR

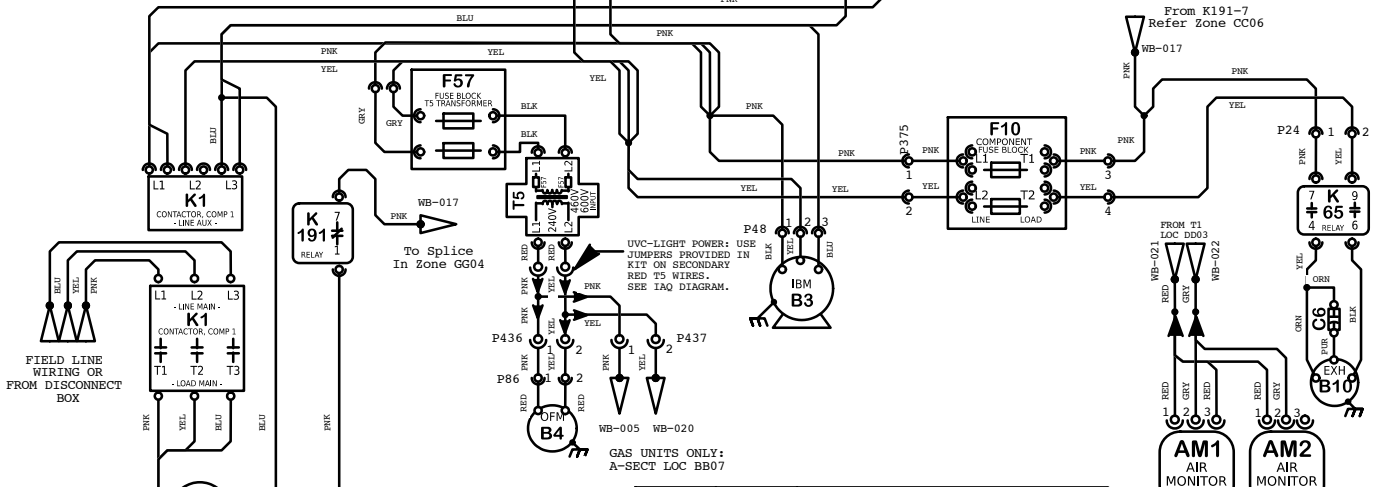
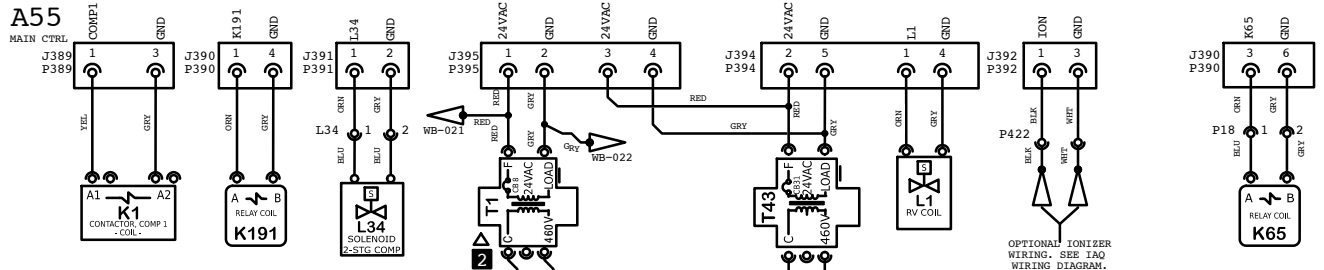
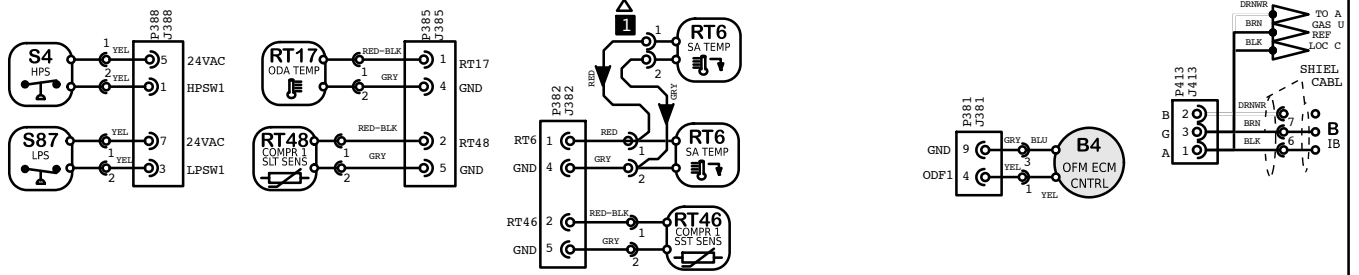

LOCATION	COMPONENT DESCRIPTION
AA01,02,03	A55 CONTROL BOARD, MAIN
HH07	AM1, AM2 AIR MONITOR, SUPPLY/RETURN, IAQ-TVOC
BB07	B1 COMPRESSOR 1
HH01,EE08	B3 MOTOR, BLOWER
GG02,DD07	B4 MOTOR, OUTDOOR FAN 1
HH06	B10 MOTOR, EXHAUST FAN 1
HH06	C6 CAPACITOR, EXHAUST FAN 1
FF05	F10 FUSE, COMPONENT
CC05	F57 FUSE, T5 TRANSFORMER PRIMARY
BB07	HR1 HEATER, COMPRESSOR 1
BB04,05,06	K1 CONTACTOR, COMPRESSOR 1
HH04,05	K65 RELAY, EXHAUST FAN 1
BB04,06	K191 RELAY, CRANKCASE HEATER 1
FF04	L34 VALVE, REVERSING 1
CC04	L34 VALVE, SOLENOID, 2 STG COMPRESSOR
EE01	RT6 SENSOR, A55 DISCHARGE (IMC)
CC01	RT17 SENSOR, OUTSIDE AIR TEMP
EE02	RT46 SENSOR, SAT. SUCT TEMP, COMP 1
CC02	RT48 SENSOR, SAT. LIQUID TEMP, COMP 1
AA01	S4 LIMIT, HI PRESS, SWITCH, COMP 1
AA01	S87 SWITCH, LOW PRESS, COMP 1
DD04	T1 TRANSFORMER, CONTROL
DD05	T5 TRANSFORMER, MOTOR
EE04	T43 TRANSFORMER, REHEAT

NOTES	
1	RT6 REMOTE MOUNT WIRING
2	MOVE WIRES FROM 240 TO 208 TAP ON TRANSFORMER FOR 208 VOLT APPLICATIONS

Model: LDT, LHT 048H - 060H G VOLT
 HEATPUMP - EBM BLOWER WITH HIGHER SCCR
 Voltage: 460V/3~/60Hz (G)
 Supersedes:N/A Form No:538201-01 Rev:0

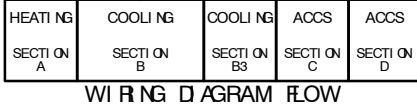

WARNING
 DISCONNECT ALL POWER BEFORE SERVICING.
 ELECTRIC SHOCK HAZARD, CAN CAUSE INJURY OR DEATH. UNIT MUST BE GROUNDED IN ACCORDANCE WITH NATIONAL AND LOCAL CODES.
 FOR USE WITH COPPER CONDUCTORS ONLY. REFER TO UNIT RATING PLATE FOR MINIMUM CIRCUIT AMPACITY AND MAXIMUM OVERCURRENT PROTECTION SIZE.
 IF ANY WIRE IN THIS APPLIANCE IS REPLACED, IT MUST BE REPLACED WITH WIRE OF LIKE SIZE, RATING AND INSULATION THICKNESS.

048H / 060H J VOLT EBM MOTOR WITHOUT SCCR

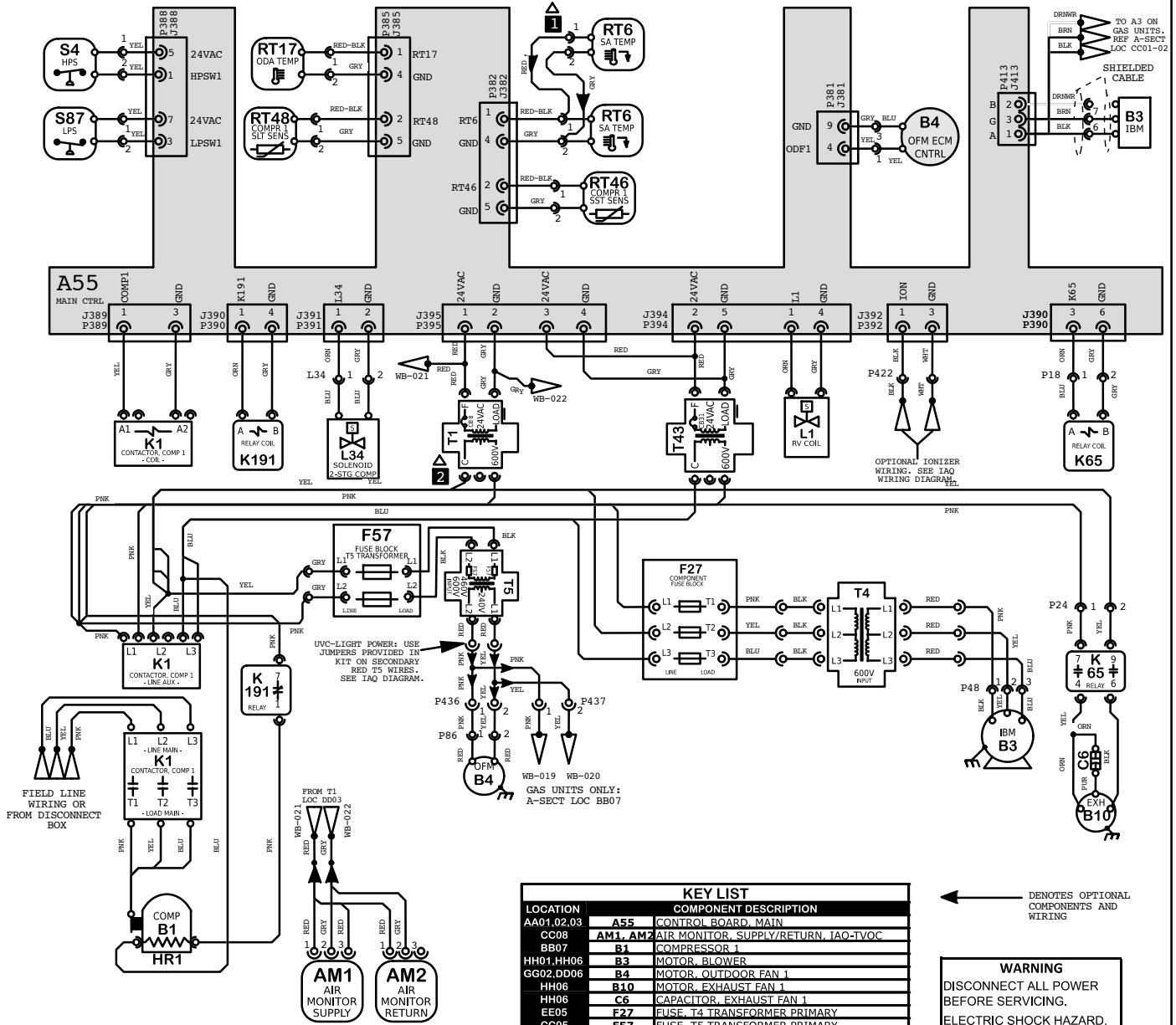

KEY LIST	
LOCATION	COMPONENT DESCRIPTION
AA01.02.03	A55 CONTROL BOARD, MAIN
CC08	AM1, AM2 AIR MONITOR, SUPPLY/RETURN, IAQ-TVOC
BB07	B1 COMPRESSOR 1
HH01, HH06	B3 MOTOR, BLOWER
GG02, DD06	B4 MOTOR, OUTDOOR FAN 1
HH06	B10 MOTOR, EXHAUST FAN 1
HH06	C6 CAPACITOR, EXHAUST FAN 1
EE05	F27 FUSE, T4 TRANSFORMER PRIMARY
CC05	F57 FUSE, T5 TRANSFORMER PRIMARY
BB07	HR1 HEATER, COMPRESSOR 1
BB04.05.06	K1 CONTACTOR, COMPRESSOR 1
HH04.05	K65 RELAY, EXHAUST FAN 1
BB04.06	K191 RELAY, CRANKCASE HEATER 1
FF04	L1 VALVE, REVERSING 1
CC04	L34 VALVE, SOLENOID, 2 STG COMPRESSOR
EE01	RT6 SENSOR, A55 DISCHARGE (IMC)
CC01	RT17 SENSOR, OUTSIDE AIR TEMP
EE02	RT46 SENSOR, SAT. SUCT. TEMP, COMP 1
CC02	RT48 SENSOR, SAT. LIQUID TEMP, COMP 1
AA01	S4 LIMIT, HI PRESS, SWITCH, COMP 1
AA01	S87 SWITCH, LOW PRESS., COMP 1
DD04	T1 TRANSFORMER, CONTROL
GG05	T4 TRANSFORMER, BLOWER
DD05	T5 TRANSFORMER, OUTDOOR FAN 1
EE04	T43 TRANSFORMER, REHEAT

NOTES	
1	RT6 REMOTE MOUNT WIRING
2	MOVE WIRES FROM 240 TO 208 TAP ON TRANSFORMER FOR 208 VOLT APPLICATIONS

Model: LDT, LHT 048H - 060H J VOLT
 HEATPUMP - EBM BLOWER WITHOUT HIGHER SCCR
 Voltage: 575V/3~/60Hz (J)
 Supersedes: N/A Form No: 538202-01 Rev: 0

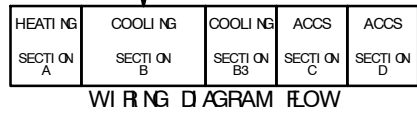

← DENOTES OPTIONAL COMPONENTS AND WIRING

WARNING
 DISCONNECT ALL POWER BEFORE SERVICING.
 ELECTRIC SHOCK HAZARD, CAN CAUSE INJURY OR DEATH. UNIT MUST BE GROUNDED IN ACCORDANCE WITH NATIONAL AND LOCAL CODES.
 FOR USE WITH COPPER CONDUCTORS ONLY. REFER TO UNIT RATING PLATE FOR MINIMUM CIRCUIT AMPACITY AND MAXIMUM OVERCURRENT PROTECTION SIZE.
 IF ANY WIRE IN THIS APPLIANCE IS REPLACED, IT MUST BE REPLACED WITH WIRE OF LIKE SIZE, RATING AND INSULATION THICKNESS.

048H / 060H J VOLT EBM MOTOR WITH SCCR

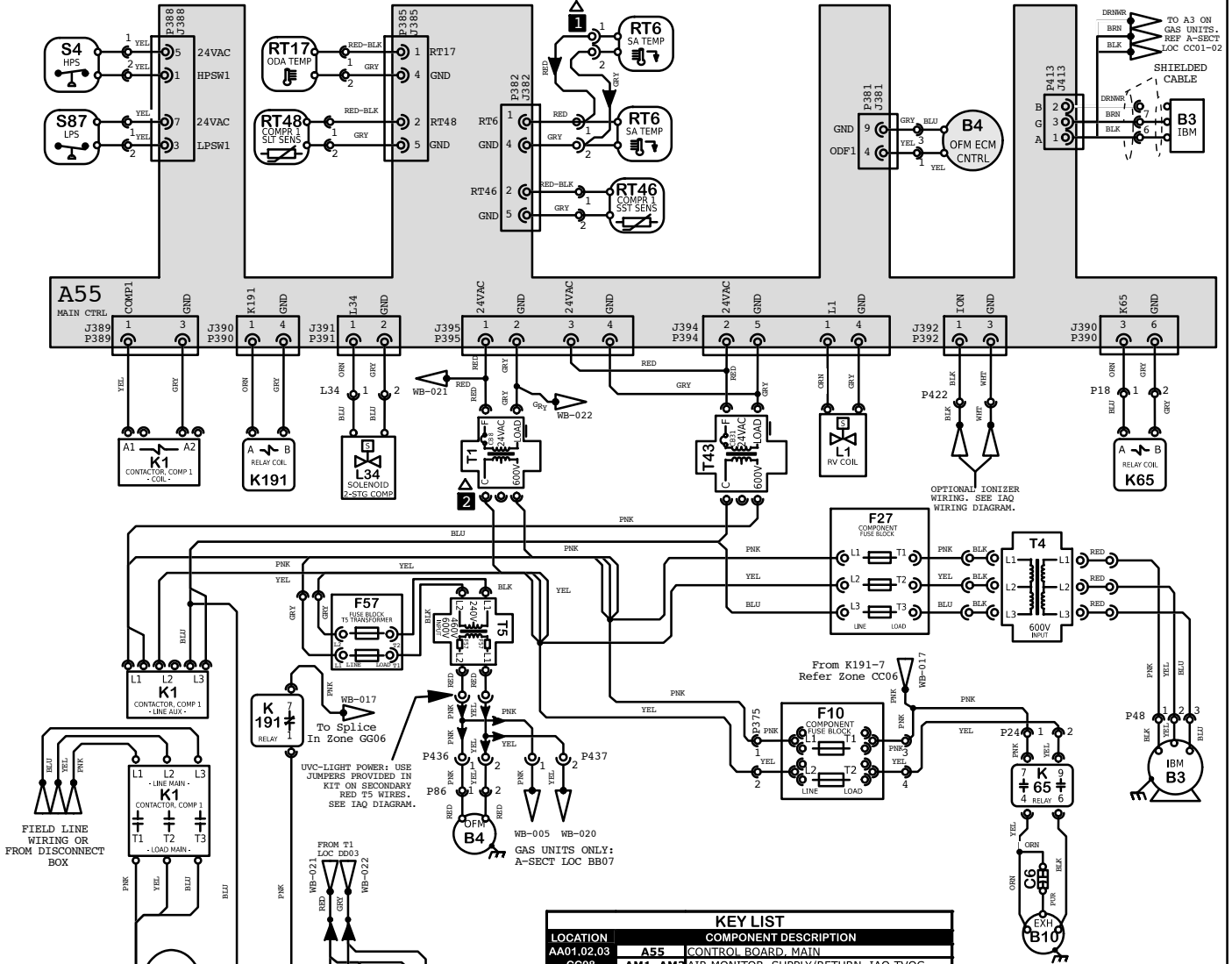

LOCATION	COMPONENT DESCRIPTION
AA01,02,03	A55 CONTROL BOARD, MAIN
CC08	AM1, AM2 AIR MONITOR, SUPPLY/RETURN, IAO-TVOC
BB07	B1 COMPRESSOR 1
HH01,HH06	B3 MOTOR, BLOWER
GG02,DD06	B4 MOTOR, OUTDOOR FAN 1
HH08	B10 MOTOR, EXHAUST FAN 1
HH08	C6 CAPACITOR, EXHAUST FAN 1
FF08	F10 FUSE, COMPONENT
CC05	F27 FUSE, T4 TRANSFORMER PRIMARY
BB08	F57 FUSE, T5 TRANSFORMER PRIMARY
BB08	HR1 HEATER, COMPRESSOR 1
BB04,05,06	K1 CONTACTOR, COMPRESSOR 1
HH04,06	K65 RELAY, EXHAUST FAN 1
BB04,06	K191 RELAY, CRANKCASE HEATER 1
FF04	L1 VALVE, REVERSING 1
CC04	L34 VALVE, SOLENOID, 2 STG COMPRESSOR
EE01	RT6 SENSOR, A55 DISCHARGE (IMC)
CC01	RT17 SENSOR, OUTSIDE AIR TEMP
EE02	RT46 SENSOR, SAT. SUCT. TEMP, COMP 1
CC02	RT48 SENSOR, SAT. LIQUID TEMP, COMP 1
AA01	S4 (LIMIT, HI PRESS. SWITCH, COMP 1
AA01	S87 SWITCH, LOW PRESS., COMP 1
DD04	T1 TRANSFORMER, CONTROL
HH05	T4 TRANSFORMER, BLOWER
DD05	T5 TRANSFORMER, OUTDOOR FAN 1
EE04	T43 TRANSFORMER, REHEAT

NOTES	
1	RT6 REMOTE MOUNT WIRING
2	MOVE WIRES FROM 240 TO 208 TAP ON TRANSFORMER FOR 208 VOLT APPLICATIONS

Model: LDT, LHT 048H - 060H J VOLT
 HEATPUMP - EBM BLOWER WITH HIGHER SCCR
 Voltage: 575V/3~/60Hz (J)
 Supersedes:N/A Form No:538203-01 Rev:0

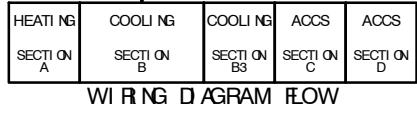

← DENOTES OPTIONAL COMPONENTS AND WIRING

WARNING
 DISCONNECT ALL POWER BEFORE SERVICING.
 ELECTRIC SHOCK HAZARD, CAN CAUSE INJURY OR DEATH. UNIT MUST BE GROUNDED IN ACCORDANCE WITH NATIONAL AND LOCAL CODES.
 FOR USE WITH COPPER CONDUCTORS ONLY, REFER TO UNIT RATING PLATE FOR MINIMUM CIRCUIT AMPACITY AND MAXIMUM OVERCURRENT PROTECTION SIZE.
 IF ANY WIRE IN THIS APPLIANCE IS REPLACED, IT MUST BE REPLACED WITH WIRE OF LIKE SIZE, RATING AND INSULATION THICKNESS.

036H / 060H P, Y VOLT ECM MOTOR WITHOUT SCCR

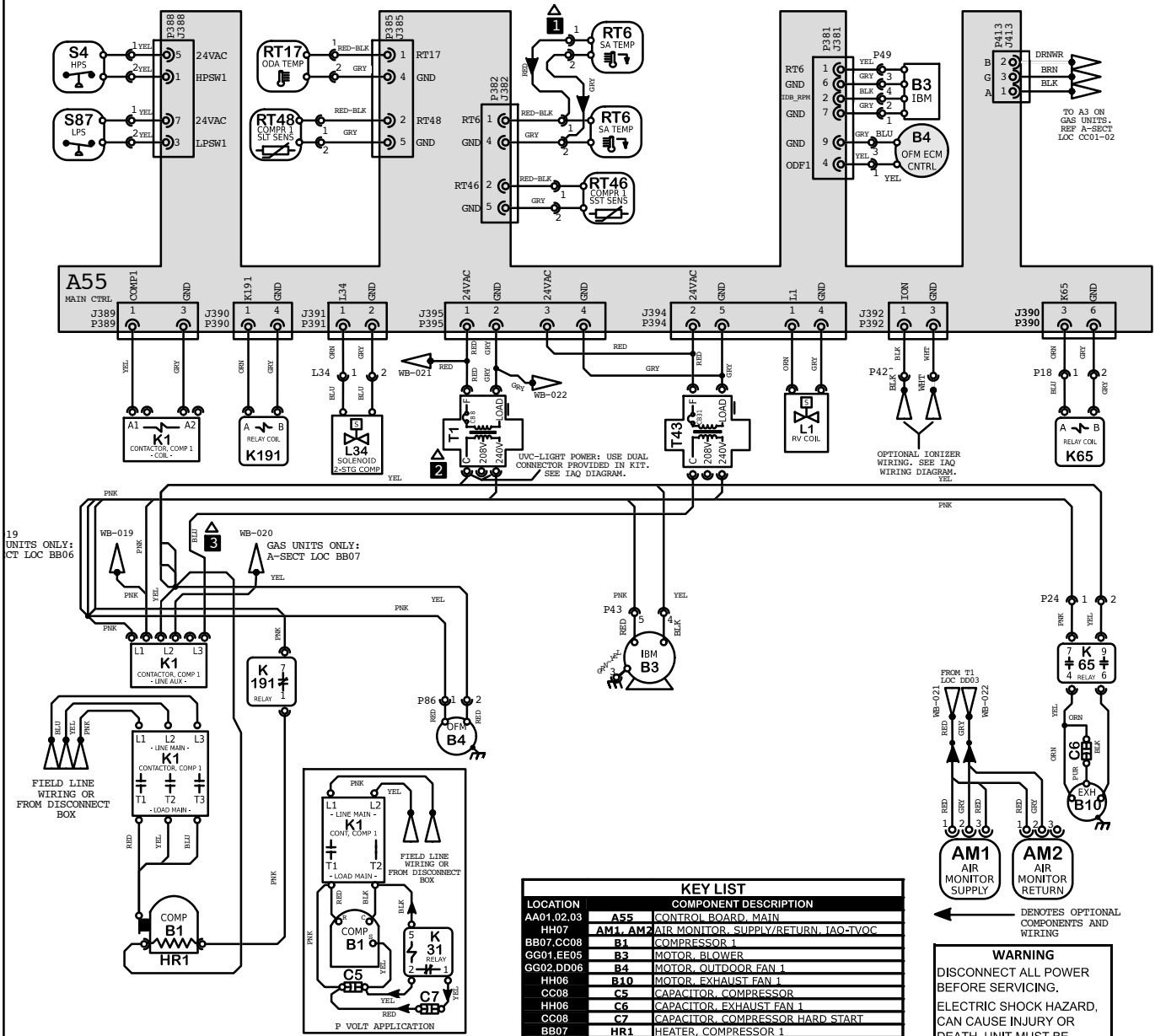

19 UNITS ONLY:
CT LOC BB06

GAS UNITS ONLY:
A-SECT LOC BB07

FIELD LINE
WIRING OR
FROM DISCONNECT
BOX

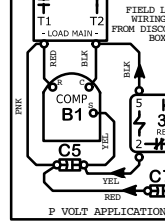

LOCATION	COMPONENT DESCRIPTION
AA01,02,03	A55 CONTROL BOARD, MAIN
HH07	AM1, AM2 AIR MONITOR, SUPPLY/RETURN, IAQ-TVOC
BB07,CC08	B1 COMPRESSOR 1
GG04,EE05	B2 MOTOR, BLOWER
GG02,DD06	B4 MOTOR, OUTDOOR FAN 1
HH06	B10 MOTOR, EXHAUST FAN 1
CC08	C5 CAPACITOR, COMPRESSOR
HH08	C6 CAPACITOR, EXHAUST FAN 1
CC08	C7 CAPACITOR, COMPRESSOR HARD START
BB07	HR1 HEATER, COMPRESSOR 1
BB04,05,06	K1 CONTACTOR, COMPRESSOR 1
DD08	K31 RELAY, HARD START KIT
HH04,05	K65 RELAY, EXHAUST FAN 1
BB04,05	K191 RELAY, CRANKCASE HEATER 1
FF04	L1 VALVE, REVERSING 1
CC04	L34 VALVE, SOLENOID, 2 STG COMPRESSOR
EE01	RT6 SENSOR, A55 DISCHARGE (IMC)
CC01	RT17 SENSOR, OUTSIDE AIR TEMP
EE02	RT46 SENSOR, SAT. SUCT. TEMP, COMP 1
CC02	RT48 SENSOR, SAT. LIQUID TEMP, COMP 1
AA01	S4 LIMIT, HI PRESS. SWITCH, COMP 1
AA01	S87 SWITCH, LOW PRESS., COMP 1
DD04	T1 TRANSFORMER, CONTROL
EE04	T43 TRANSFORMER, REHEAT

NOTES	
1	RT6 REMOTE MOUNT WIRING
2	MOVE WIRES FROM 240 TO 208 TAP ON TRANSFORMER FOR 208 VOLT APPLICATIONS
3	P-VOLT UNITS - CONNECT T43-C TO K1-L2

← DENOTES OPTIONAL COMPONENTS AND WIRING

WARNING

DISCONNECT ALL POWER BEFORE SERVICING.

ELECTRIC SHOCK HAZARD, CAN CAUSE INJURY OR DEATH. UNIT MUST BE GROUNDED IN ACCORDANCE WITH NATIONAL AND LOCAL CODES.

FOR USE WITH COPPER CONDUCTORS ONLY. REFER TO UNIT RATING PLATE FOR MINIMUM CIRCUIT AMPACITY AND MAXIMUM OVERCURRENT PROTECTION SIZE.

IF ANY WIRE IN THIS APPLIANCE IS REPLACED, IT MUST BE REPLACED WITH WIRE OF LIKE SIZE, RATING AND INSULATION THICKNESS.

Model: LDT, LHT 024H - 060H P, Y VOLT
HEATPUMP - ECM BLOWER WITHOUT HIGHER SCCR
Voltage: 208-240V/1~/60Hz(P), 208-240V/3~/60Hz
Supersedes N/A Form No:538194-01 Rev:0

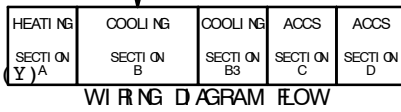

036H / 060H P, Y VOLT ECM MOTOR WITH SCCR

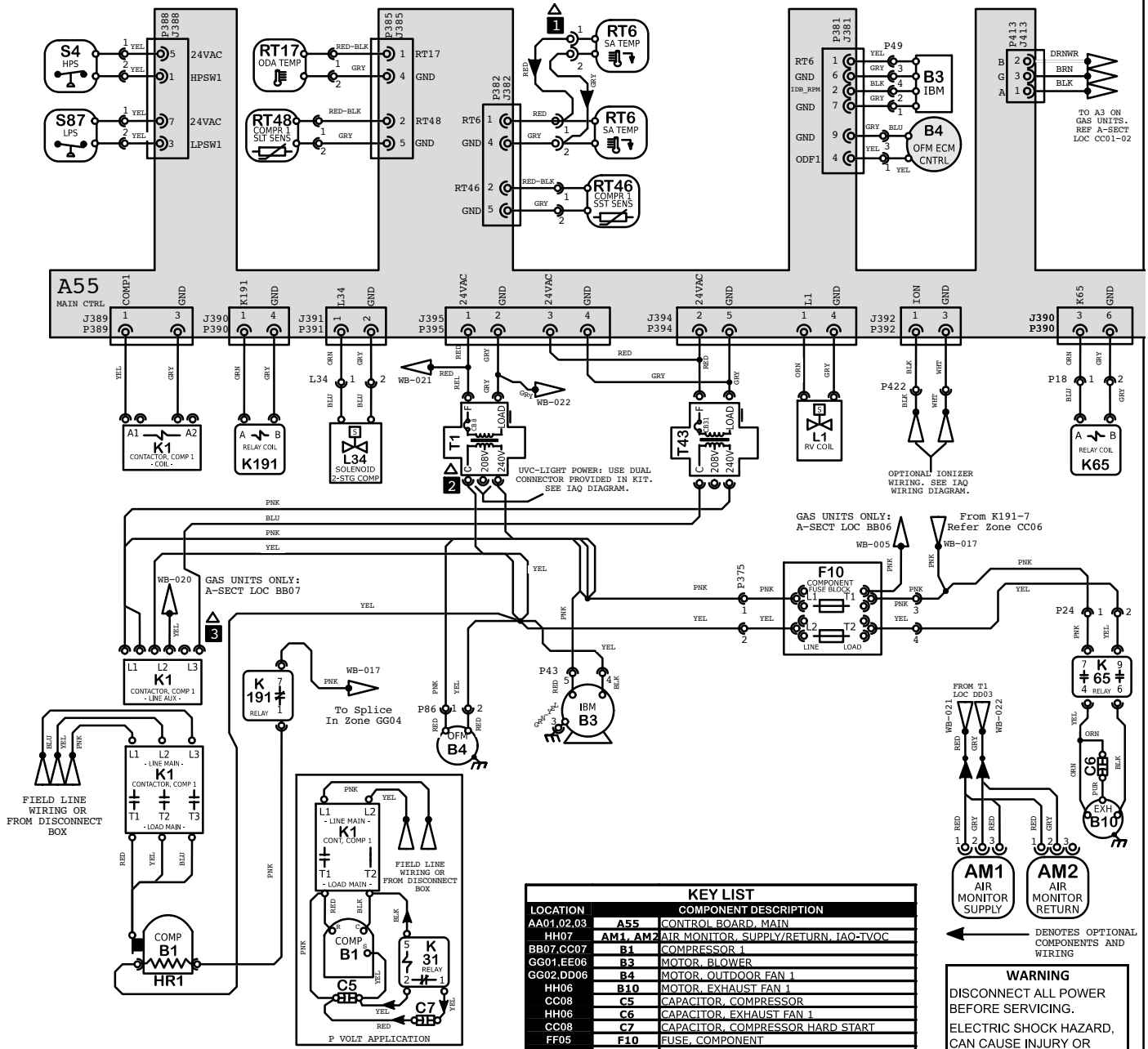

NOTES	
1	RT6 REMOTE MOUNT WIRING
2	MOVE WIRES FROM 240 TO 208 TAP ON TRANSFORMER FOR 208 VOLT APPLICATIONS
3	P-VOLT UNITS - CONNECT T43-C TO K1-L2

KEY LIST	
LOCATION	COMPONENT DESCRIPTION
AA01,02,03	A55 CONTROL BOARD, MAIN
HH07	AM1, AM2 AIR MONITOR SUPPLY/RETURN, IAO-TVOC
BB07,CC07	B1 COMPRESSOR 1
GG04,EE06	B3 MOTOR, BLOWER
GG02,DD06	B4 MOTOR, OUTDOOR FAN 1
HH06	B10 MOTOR, EXHAUST FAN 1
CC08	C5 CAPACITOR, COMPRESSOR
HH06	C6 CAPACITOR, EXHAUST FAN 1
CC08	C7 CAPACITOR, COMPRESSOR HARD START
FF05	F10 FUSE, COMPONENT
BB07	HR1 HEATER, COMPRESSOR 1
BB04,05,06	K1 CONTACTOR, COMPRESSOR 1
DD08	K31 RELAY, HARD START KIT
HH04,05	K65 RELAY, EXHAUST FAN 1
BB04,06	K191 RELAY, CRANKCASE HEATER 1
FF04	L1 VALVE, REVERSING 1
CC04	L34 VALVE, SOLENOID, 2 STG COMPRESSOR
EE01	RT6 SENSOR, A55 DISCHARGE (IMC)
CC01	RT17 SENSOR, OUTSIDE AIR TEMP
EE02	RT46 SENSOR, SAT. SUCT. TEMP., COMP 1
CC02	RT48 SENSOR, SAT. LIQUID TEMP., COMP 1
AA01	S4 LIMIT, HI PRESS., SWITCH, COMP 1
AA01	S87 SWITCH, LOW PRESS., COMP 1
DD04	T1 TRANSFORMER, CONTROL
EE04	T43 TRANSFORMER, REHEAT

Model: LDT, LHT 024H - 060H P, Y VOLT
 HEATPUMP - ECM BLOWER WITH HIGHER SCCR
 Voltage: 208-240V/1~/60Hz(P), 208-240V/3~/60Hz(Y)
 Supersedes: N/A Form No: 538195-01 Rev: 0

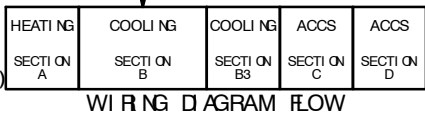

WARNING
 DISCONNECT ALL POWER BEFORE SERVICING.
 ELECTRIC SHOCK HAZARD, CAN CAUSE INJURY OR DEATH. UNIT MUST BE GROUNDED IN ACCORDANCE WITH NATIONAL AND LOCAL CODES.
 FOR USE WITH COPPER CONDUCTORS ONLY, REFER TO UNIT RATING PLATE FOR MINIMUM CIRCUIT AMPACITY AND MAXIMUM OVERCURRENT PROTECTION SIZE.
 IF ANY WIRE IN THIS APPLIANCE IS REPLACED, IT MUST BE REPLACED WITH WIRE OF LIKE SIZE, RATING AND INSULATION THICKNESS.

048H / 060H Y VOLT EMB MOTOR WITHOUT SCCR

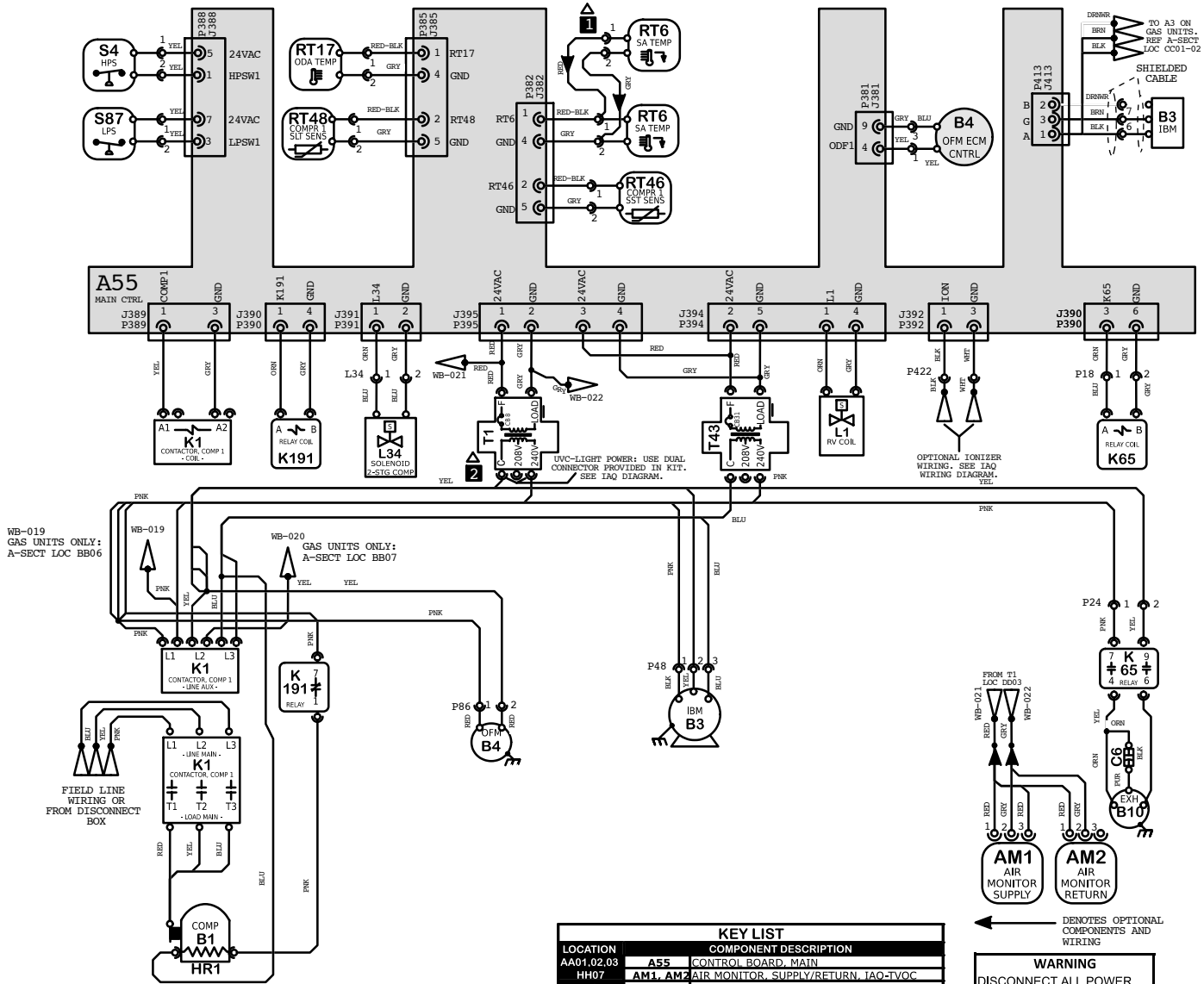

WB-019
GAS UNITS ONLY:
A-SECT LOC BB06

WB-020
GAS UNITS ONLY:
A-SECT LOC BB07

LOCATION	COMPONENT DESCRIPTION
AA01,02,03	A55 CONTROL BOARD, MAIN
HH07	AM1, AM2 AIR MONITOR, SUPPLY/RETURN, IAQ-TVOC
BB07	B1 COMPRESSOR 1
HH01,EE06	B3 MOTOR, BLOWER
GG02,DD06	B4 MOTOR, OUTDOOR FAN 1
HH06	B10 MOTOR, EXHAUST FAN 1
HH06	C6 CAPACITOR, EXHAUST FAN 1
BB07	HR1 HEATER, COMPRESSOR 1
BB04,05,06	K1 CONTACTOR, COMPRESSOR 1
HH04,05	K65 RELAY, EXHAUST FAN 1
BB04,06	K191 RELAY, CRANKCASE HEATER 1
FF04	L1 VALVE, REVERSING 1
CC04	L34 VALVE, SOLENOID, 2 STG COMPRESSOR
EE01	RT6 SENSOR, A55 DISCHARGE (IMC)
CC01	RT17 SENSOR, OUTSIDE AIR TEMP
EE02	RT46 SENSOR, SAT. SUCT. TEMP, COMP 1
CC02	RT48 SENSOR, SAT. LIQUID TEMP, COMP 1
AA01	S4 (LIMIT, HI PRESS. SWITCH, COMP 1
AA01	S87 SWITCH, LOW PRESS., COMP 1
DD04	T1 TRANSFORMER, CONTROL
EE04	T43 TRANSFORMER, REHEAT

NOTES	
1	RT6 REMOTE MOUNT WIRING
2	MOVE WIRES FROM 240 TO 208 TAP ON TRANSFORMER FOR 208 VOLT APPLICATIONS

← DENOTES OPTIONAL COMPONENTS AND WIRING

WARNING
DISCONNECT ALL POWER BEFORE SERVICING.
ELECTRIC SHOCK HAZARD, CAN CAUSE INJURY OR DEATH. UNIT MUST BE GROUNDED IN ACCORDANCE WITH NATIONAL AND LOCAL CODES.
FOR USE WITH COPPER CONDUCTORS ONLY, REFER TO UNIT RATING PLATE FOR MINIMUM CIRCUIT AMPACITY AND MAXIMUM OVERCURRENT PROTECTION SIZE.
IF ANY WIRE IN THIS APPLIANCE IS REPLACED, IT MUST BE REPLACED WITH WIRE OF LIKE SIZE, RATING AND INSULATION THICKNESS.

Model: LDT, LHT 048H - 060H Y VOLT
HEATPUMP - EBM BLOWER WITHOUT HIGHER SCCR
Voltage: 208-240V/3~/60Hz (Y)
Supersedes N/A Form No: 538198-01 Rev: 0

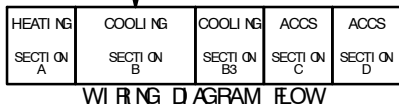

048H / 060H Y VOLT EBM MOTOR WITH SCCR

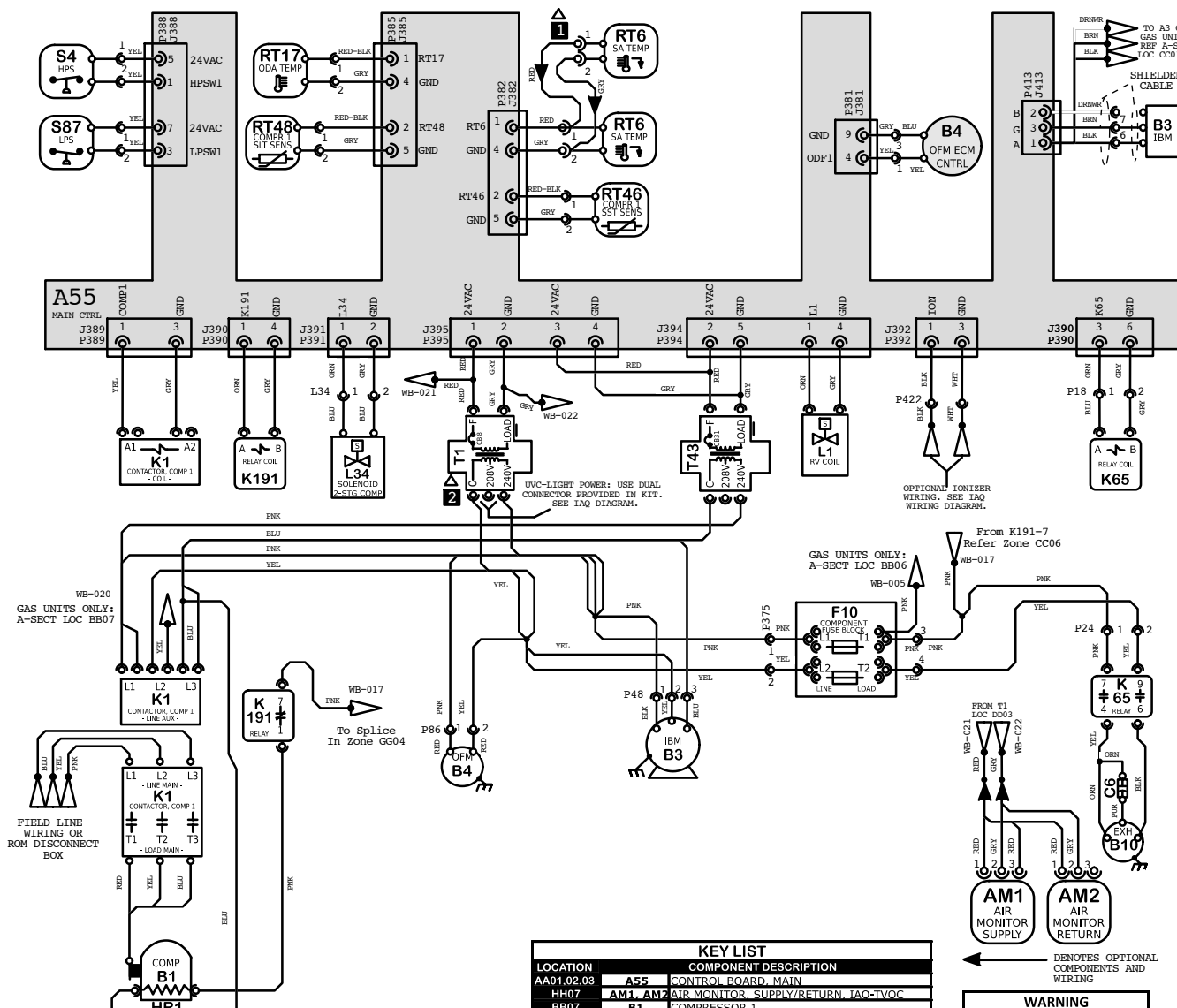

GAS UNITS ONLY:
A-SECT LOC BB07

FIELD LINE
WIRING OR
FROM DISCONNECT
BOX

UVV-LIGHT POWER: USE DUAL
CONNECTOR PROVIDED IN KIT.
SEE IAQ DIAGRAM.

OPTIONAL IONIZER
WIRING. SEE IAQ
WIRING DIAGRAM.

GAS UNITS ONLY:
A-SECT LOC BB06

From K191-7
Refer Zone CC06

NOTES	
1	RT6 REMOTE MOUNT WIRING
2	MOVE WIRES FROM 240 TO 208 TAP ON TRANSFORMER FOR 208 VOLT APPLICATIONS

KEY LIST		
LOCATION	COMPONENT	DESCRIPTION
AA01.02.03	A55	CONTROL BOARD, MAIN
HH07	AM1, AM2	AIR MONITOR, SUPPLY/RETURN, IAQ-TVOC
BB07	B1	COMPRESSOR 1
HH01.EE06	B3	MOTOR, BLOWER
GG02.DD06	B4	MOTOR, OUTDOOR FAN 1
HH06	B10	MOTOR, EXHAUST FAN 1
HH06	C6	CAPACITOR, EXHAUST FAN 1
FF05	F10	FUSE, COMPONENT
BB07	HR1	HEATER, COMPRESSOR 1
BB04.05.06	K1	CONTACTOR, COMPRESSOR 1
HH04.05	K65	RELAY, EXHAUST FAN 1
BB04.06	K191	RELAY, CRANKCASE HEATER 1
FF04	L1	VALVE, REVERSING 1
CC04	L34	VALVE, SOLENOID, 2 STG COMPRESSOR
EE01	RT6	SENSOR, A55 DISCHARGE (TMC)
CC01	RT17	SENSOR, OUTSIDE AIR TEMP
EE02	RT46	SENSOR, SAT. SUCT. TEMP., COMP 1
CC02	RT48	SENSOR, SAT. LIQUID TEMP., COMP 1
AA01	S4	LIMIT, HI PRESS., SWITCH, COMP 1
AA01	S87	SWITCH, LOW PRESS., COMP 1
DD04	T1	TRANSFORMER, CONTROL
EE04	T43	TRANSFORMER, REHEAT

Model: LDT, LHT 048H - 060H Y VOLT
HEATPUMP - EBM BLOWER WITH HIGHER SCCR
Voltage: 208-240V/3~/60Hz (Y)
Supersedes N/A Form No: 538199-01 Rev: 0

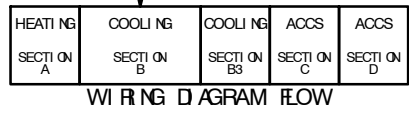

WARNING
DISCONNECT ALL POWER BEFORE SERVICING.
ELECTRIC SHOCK HAZARD, CAN CAUSE INJURY OR DEATH. UNIT MUST BE GROUNDED IN ACCORDANCE WITH NATIONAL AND LOCAL CODES.
FOR USE WITH COPPER CONDUCTORS ONLY, REFER TO UNIT RATING PLATE FOR MINIMUM CIRCUIT AMPACITY AND MAXIMUM OVERCURRENT PROTECTION SIZE.
IF ANY WIRE IN THIS APPLIANCE IS REPLACED, IT MUST BE REPLACED WITH WIRE OF LIKE SIZE, RATING AND INSULATION THICKNESS.

Cooling Sequence of Operation

Power:

- 1- Line voltage energizes transformer T1. T1 provides 24VAC power to the A55 Unit Controller. A55 provides 24VAC to the unit cooling, heating and blower controls.
- 2- Line voltage provides voltage to compressor crankcase heater relay K191-1 N.C. contacts, compressor contactor K1, blower motor B3, and outdoor fan motor B4 (on G volt units line voltage is supplied to two fuses F27, transformer T4, blower motor B3, and outdoor fan motor B4).

Blower Operation:

- 3- The A55 Unit Controller receives a demand from thermostat terminal G. A55 energizes blower motor B3 via programmed motor settings. Motor settings are field-adjustable.

First Stage Cooling

- 4- A55 Unit Controller receives Y1 and G cooling demand.
- 5- After A55 proves n.c. low pressure switch S87, n.c. SST, and n.c. high pressure switch S4, reversing valve (L1), compressor contactor K1 and Blower B3 are energized.
- 6- N.O. contacts K1-1 close energizing the compressor B1 (Low for 036, 048, -060 units and On for -024 units)
- 7- SLT prove below 62°F. A55 energized outdoor fan motor B4 to modulate. If above 65°F, outdoor fan motor B4 will be set to low speed.

Second Stage Cooling

- 8- .A55 received a Y2 and G cooling demand and energizes blower B3 on high speed.
- 9- A55 Energizes compressor solenoid L34, switching compressor to high speed (036, 048 and 060 units only)

Power Exhaust Fan Operation

- 10- A55 receives a position feedback signal from the economizer damper motor and energizes exhaust fan relay K65 with 24VAC at 50% outside air damper open (adjustable).
- 11- N.O. contact K65-1 & 2 close, energizing exhaust fan motor B10.

2-STAGE GAS HEAT FOR UNITS

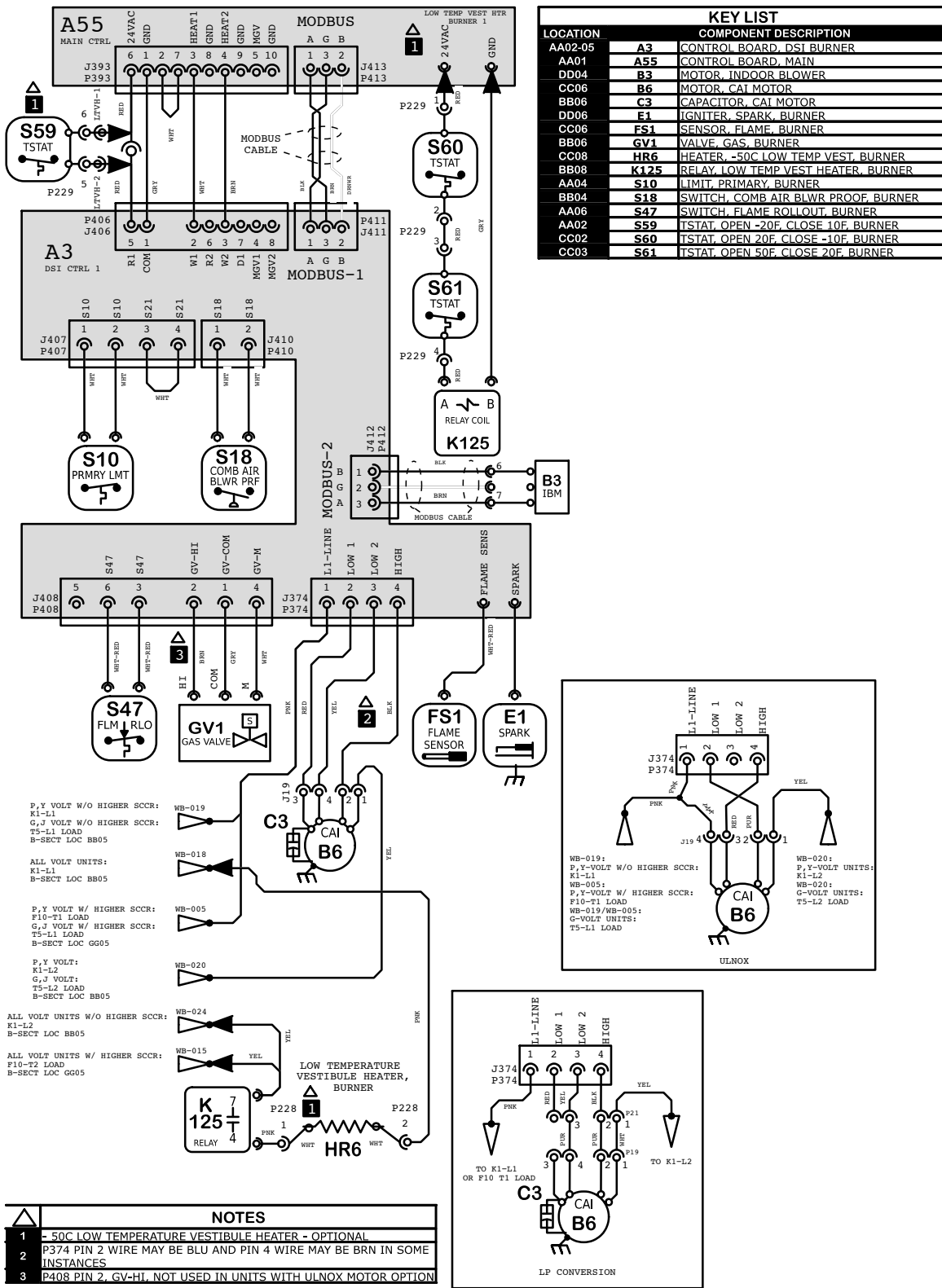

LOCATION	COMPONENT DESCRIPTION
AA02-05	A3 CONTROL BOARD, DSI BURNER
AA01	A55 CONTROL BOARD, MAIN
DD04	B3 MOTOR, INDOOR BLOWER
CC06	B6 MOTOR, CAI MOTOR
BB06	C3 CAPACITOR, CAI MOTOR
DD06	F1 IGNITER, SPARK, BURNER
CC06	FS1 SENSOR, FLAME, BURNER
BB06	GV1 VALVE, GAS, BURNER
CC08	HR6 HEATER, -50C LOW TEMP VEST, BURNER
BB08	K125 RELAY, LOW TEMP VEST HEATER, BURNER
AA04	S10 LIMIT, PRIMARY, BURNER
BB04	S18 SWITCH, COMB AIR BLWR PROOF, BURNER
AA06	S47 SWITCH, FLAME ROLLOUT, BURNER
AA02	S59 TSTAT, OPEN -20F, CLOSE 10F, BURNER
CC02	S60 TSTAT, OPEN 20F, CLOSE -10F, BURNER
CC03	S61 TSTAT, OPEN 50F, CLOSE 20F, BURNER

P, Y VOLT W/O HIGHER SCCR:
K1-L1
G, J VOLT W/O HIGHER SCCR:
TS-L1 LOAD
B-SECT LOC BB05

ALL VOLT UNITS:
K1-L1
B-SECT LOC BB05

P, Y VOLT W/ HIGHER SCCR:
F10-T1 LOAD
G, J VOLT W/ HIGHER SCCR:
TS-L1 LOAD
B-SECT LOC GG05

P, Y VOLT:
K1-L2
G, J VOLT:
TS-L2 LOAD
B-SECT LOC BB05

ALL VOLT UNITS W/O HIGHER SCCR:
K1-L2
B-SECT LOC BB05

ALL VOLT UNITS W/ HIGHER SCCR:
F10-T2 LOAD
B-SECT LOC GG05

LOW TEMPERATURE VESTIBULE HEATER, BURNER

NOTES	
1	- 50C LOW TEMPERATURE VESTIBULE HEATER - OPTIONAL
2	P374 PIN 2 WIRE MAY BE BLU AND PIN 4 WIRE MAY BE BRN IN SOME INSTANCES
3	P408 PIN 2, GV-HI, NOT USED IN UNITS WITH ULNOX MOTOR OPTION

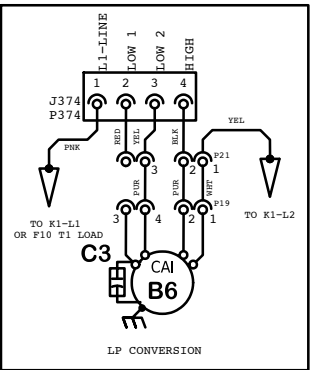
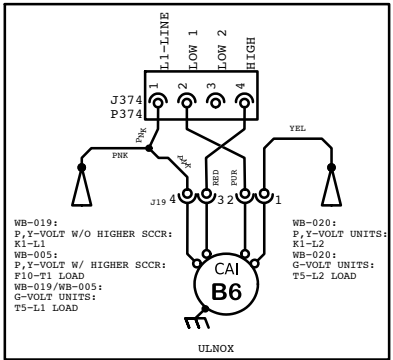

← DENOTES OPTIONAL COMPONENTS AND WIRING

Model: LGT, LDT SERIES RTU - GAS HEAT
 Input Heat Capacity 60k - 150k Btuh
 Voltage: 208-240/3/60(Y), 460/3/60(G), 575/3/60(J)
 Supersedes: N/A Form No: 538237-01 Rev: 0

© 2019

HEATING	COOLING	COOLING	ACCS	ACCS
SECTION A	SECTION B	SECTION B3	SECTION C	SECTION D
X	X	X	X	X

WIRING DIAGRAM FLOW

HEATING SEQUENCE OF OPERATION

Heating Type Determination

- 1 - The thermostat initiates W1 heating demand
- 2 - If outdoor air temperature **above** Balance Point Set Point, proceed to Heat Pump Heat. If outdoor temperature **below** Balance Point Set Point, proceed to First Stage Heat.

Blower Operation

- 3 - The A55 Unit Controller receives a demand from thermostat terminal G. A55 energizes blower motor B3 via programmed motor settings. Motor settings are field-adjustable.

Heat Pump Heat

- 1 - A55 Unit Controller receives W1 and G heating demand.
- 2 - After A55 proves n.c. low pressure switch S87, n.c. high pressure switch S4, OAT above Balance Point Set Point, compressor contactor K1, Blower, and Fan is energized.

NOTE - For 024 units in Mechanical Heating, the unit will automatically stage up for outdoor temperatures below 40°F for increased performance and efficiency. No external intervention is required, operation is automatic. At temperatures above 40°F, compressor will stage down to maintain operation efficiency.

First Stage Heat

- 1 - The thermostat initiates W1 heating demand.
- 2 - 24VAC is routed to controller A3. A3 proves N.C. primary limit S10.
- 3 - Control board A3 energizes combustion air inducer B6. After B6 has reached full speed, the combustion air blower proving switch S18 contacts close.
- 4 - After a 30 second delay A3 energizes the ignitor and gas valve GV1 on first stage.

Second Stage Heat

- 5 - With first stage heat operating, an additional heating demand from the thermostat initiates W2.
- 6 - A second stage heating demand is received by A55.
- 7 - A3 energizes HI terminal (high fire) of gas valve.
- 8 - A3 energizes combustion air inducer B6 on high speed.

End of Second Stage Heat

- 9 - Heating demand is satisfied. Terminal HI (second stage) is de-energized.
- 10 - Second stage heat is de-energized on GV1.
- 11 - Combustion air inducer B6 is now on low speed.

End of First Stage Heat

- 12 - Heating demand is satisfied. Terminal W1 (first stage) is de-energized.
- 13 - Ignition A3 is de-energized in turn de-energizing gas valve GV1 and combustion air inducer B6.

Optional Low Ambient Kit: (C.S.A. -50° C Low Ambient Kit)

- 14 - Line voltage is routed through the N.C. low ambient kit thermostats S60 and S61, to energize low ambient kit heater HR6.

ELECTRONIC OR ELECTROMECHANICAL THERMOSTAT

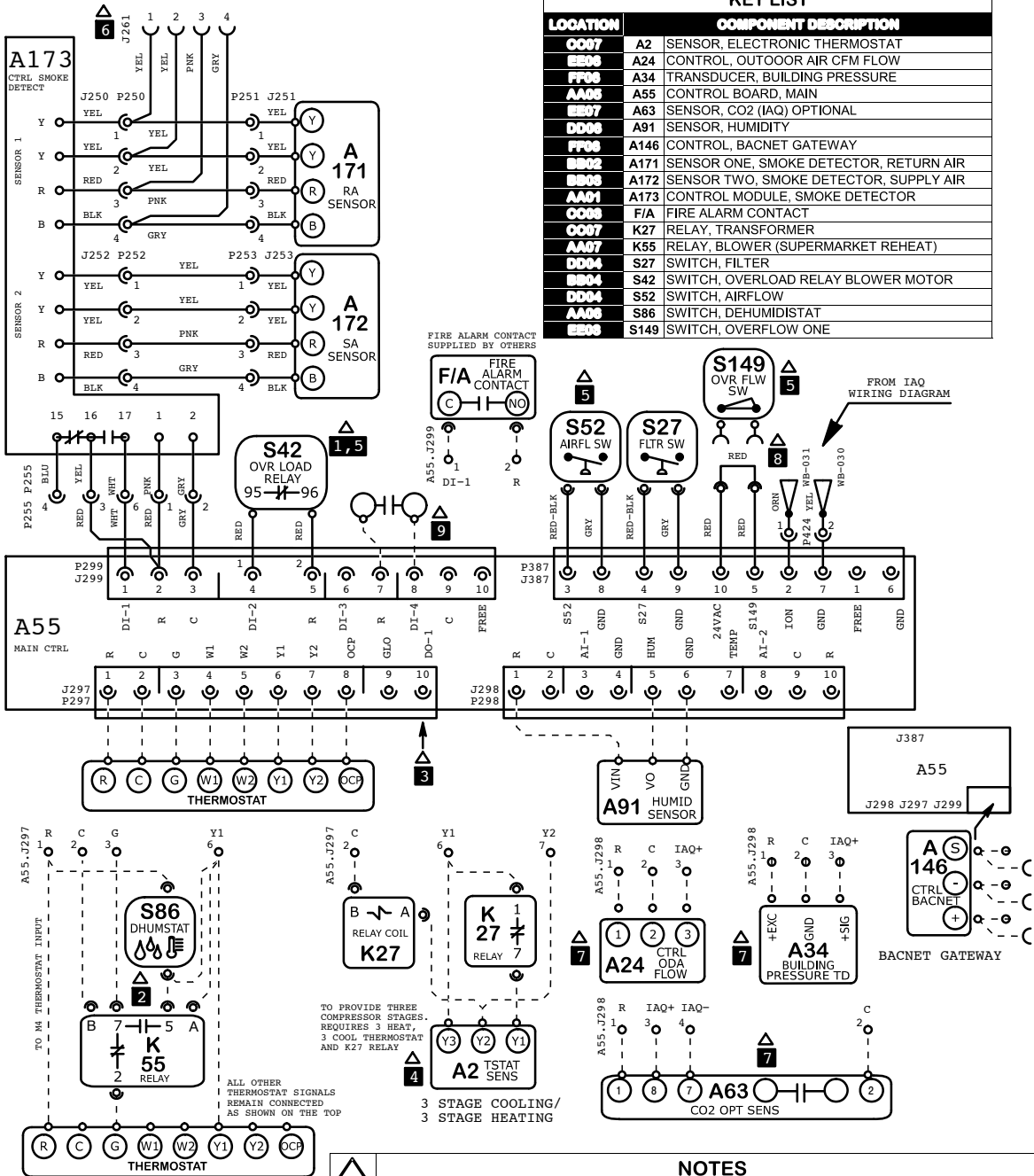

KEY LIST		
LOCATION	COMPONENT DESCRIPTION	
CO07	A2	SENSOR, ELECTRONIC THERMOSTAT
BB06	A24	CONTROL, OUTDOOR AIR CFM FLOW
FF06	A34	TRANSDUCER, BUILDING PRESSURE
AA06	A55	CONTROL BOARD, MAIN
BB07	A63	SENSOR, CO2 (IAQ) OPTIONAL
DD08	A91	SENSOR, HUMIDITY
FF08	A146	CONTROL, BACNET GATEWAY
BB02	A171	SENSOR ONE, SMOKE DETECTOR, RETURN AIR
BB08	A172	SENSOR TWO, SMOKE DETECTOR, SUPPLY AIR
AA01	A173	CONTROL MODULE, SMOKE DETECTOR
CO08	F/A	FIRE ALARM CONTACT
CO07	K27	RELAY, TRANSFORMER
AA07	K55	RELAY, BLOWER (SUPERMARKET REHEAT)
DD04	S27	SWITCH, FILTER
BB04	S42	SWITCH, OVERLOAD RELAY BLOWER MOTOR
DD04	S52	SWITCH, AIRFLOW
AA08	S86	SWITCH, DEHUMIDISTAT
BB08	S149	SWITCH, OVERFLOW ONE

NOTES	
1	FOR MOTORS WITH S42 EXTERNAL OVERLOAD LESS INVERTER, SEE INVERTER WITH BY PASS FOR S42 HOOK UP
2	USE S86 DEHUMIDISTAT AND K55 FOR OPTIONAL SUPERMARKET REHEAT SCHEME, PRODIGY PARAMETERS NEED TO BE MODIFIED UNDER THE SETTINGS MENU OR VIA UC SOFTWARE FOR SIMULTANEOUS HEATING AND COOLING
3	P297-10 (SR) IS SERVICE RELAY OUTPUT (24VAC) IF USED CONNECT TO AN INDICATOR LIGHT
4	THERMOSTAT HOOKUP FOR PROGRAMMABLE CONFIGURATION OF THE BOARD (A55)
5	PRODIGY SETTINGS MUST BE MODIFIED WHEN S42, S52, S149 ARE INSTALLED
6	CONNECT P252 OF A172 SENSOR TO J261 ON SUPPLY AIR SMOKE DETECTOR ONLY
7	FROM A63, A34 & A24, ONLY ONE CAN BE USED AT A TIME
8	REMOVE JUMPER TO INSTALL S149
9	EXTERNAL HUMIDITROL CONTACTS

TO PROVIDE SUPERMARKET REHEAT SCHEME USE S86 DEHUMIDISTAT AND K55 SUPERMARKET REHEAT

← DENOTES OPTIONAL COMPONENTS AND WIRING
 - - - - CLASS 2 FIELD WIRING

Model: LC, LG, LH, LD Series RTU
 Thermostat
 Voltage: All Voltages
 Supersedes: N/A Form No: 538078-01 Rev: 1

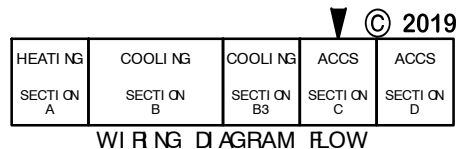

ECONOMIZER

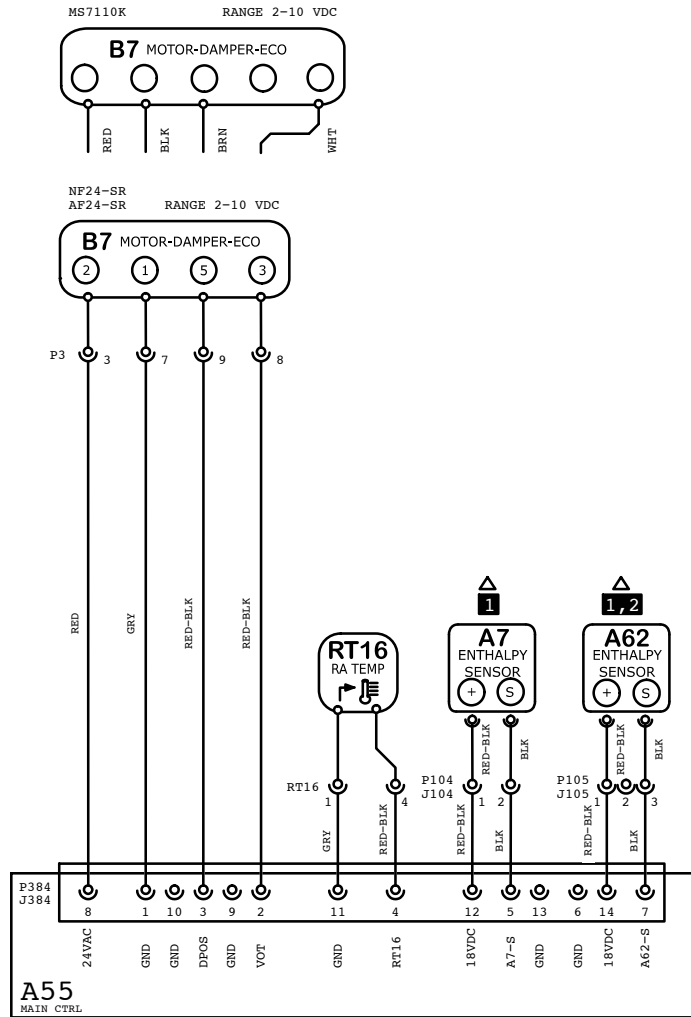

NOTES	
1	A7 AND A62 NOT USED FOR SENSIBLE TEMPERATURE CONTROL
2	FOR UNIT DIFFERENTIAL ENTHALPY CONTROL, ADD A62 RETURN AIR ENTHALPY SENSOR

KEY LIST		
LOCATION	COMPONENT DESCRIPTION	
CC06	A7	SENSOR, SOLID STATE ENTHALPY
AA06	A55	CONTROL BOARD, MAIN
DD06	A62	SENSOR, ENTHALPY INDOOR
BB02	B7	MOTOR, DAMPER ECONOMIZER
CC06	RT16	SENSOR, RETURN AIR TEMP

Model: LC, LG, LH, LD Series RTU Economizer & Motorized OAD
Voltage: All Voltages
Supersedes: N/A Form No: 538072-01 Rev: 1

© 2019
HTG SEC A CLG SEC B CLG SEC B3 ACCS SEC C ACCS SEC D
WIRING DIAGRAM FLOW

IAQ

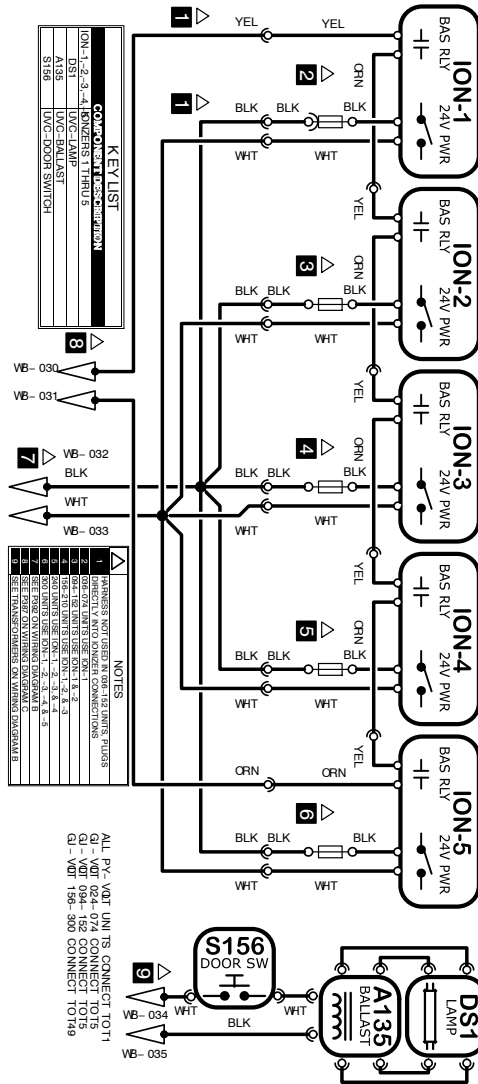

KEY LIST	
ION-1-2-3-4	IONIZERS 1 THRU 5
DS1	UVC LAMP
A135	UVC BALLAST
S156	DOOR SWITCH

NOTES	
1	WIRENESS NOT USED IN OR TO UNITS, FIELDS
2	WIRENESS NOT USED IN OR TO UNITS, FIELDS
3	WIRENESS NOT USED IN OR TO UNITS, FIELDS
4	WIRENESS NOT USED IN OR TO UNITS, FIELDS
5	WIRENESS NOT USED IN OR TO UNITS, FIELDS
6	WIRENESS NOT USED IN OR TO UNITS, FIELDS
7	WIRENESS NOT USED IN OR TO UNITS, FIELDS
8	WIRENESS NOT USED IN OR TO UNITS, FIELDS
9	WIRENESS NOT USED IN OR TO UNITS, FIELDS

ALL P.V. WDT UNIT IS CONNECT TO T1
 G1 - WDT 024 - 072 CONNECT TO T15
 G1 - WDT 024 - 072 CONNECT TO T15
 G1 - WDT 156 - 300 CONNECT TO T149

MDL: IAQ WIRING DIAGRAM
 IONIZERS & UVC
 VOLT: Y, G, J VOLT Rev: 0 538151-03
 SUPSDS: N/A NO: 538151-03



Rev: 0

POWER ENTRY NON-SCCR

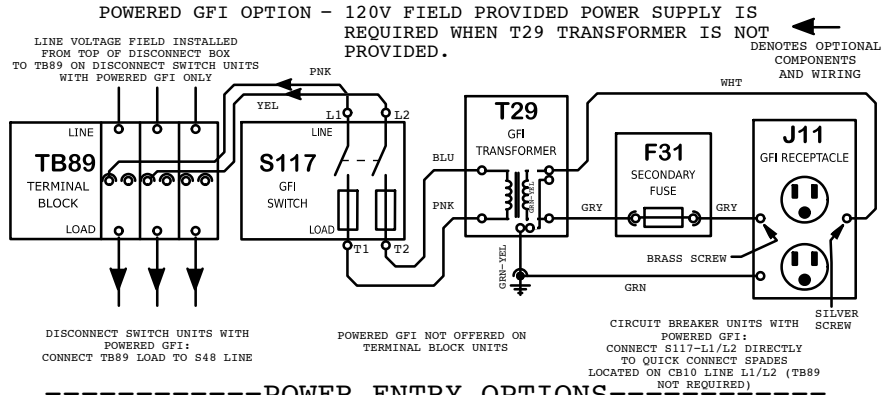

-----POWER ENTRY OPTIONS-----

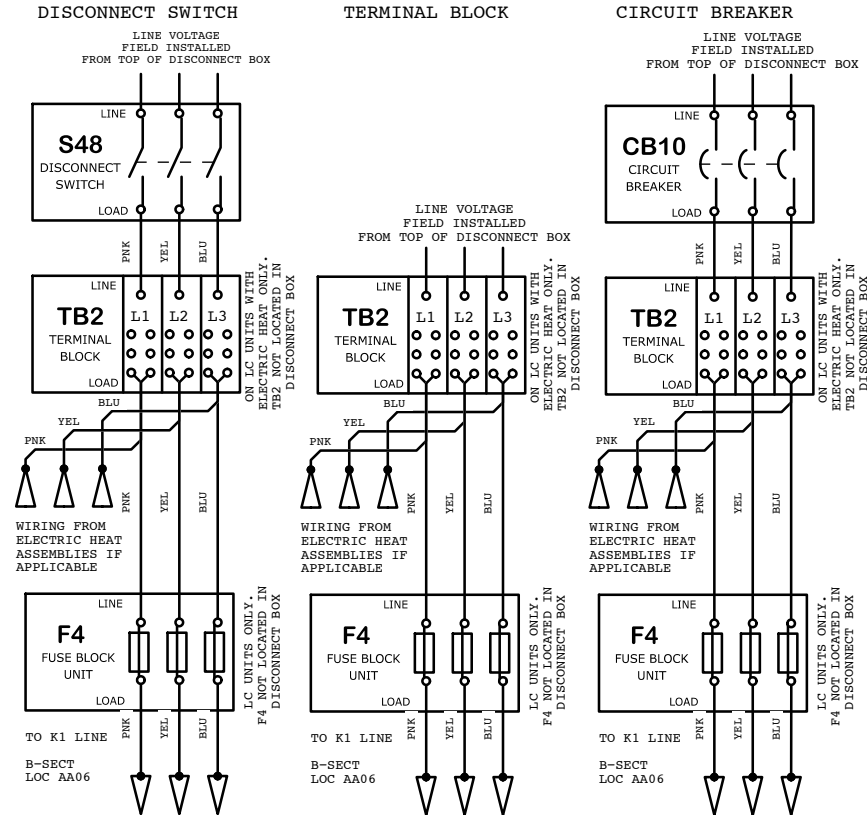

Model: LCT, LGT, LHT, LDT Series RTU
 Power Entry Options 024-074
 Voltage: All Voltages
 Supersedes: XXXXXX-XX Form No: 538234-01 Rev: 0

POWER ENTRY WITH SCCR

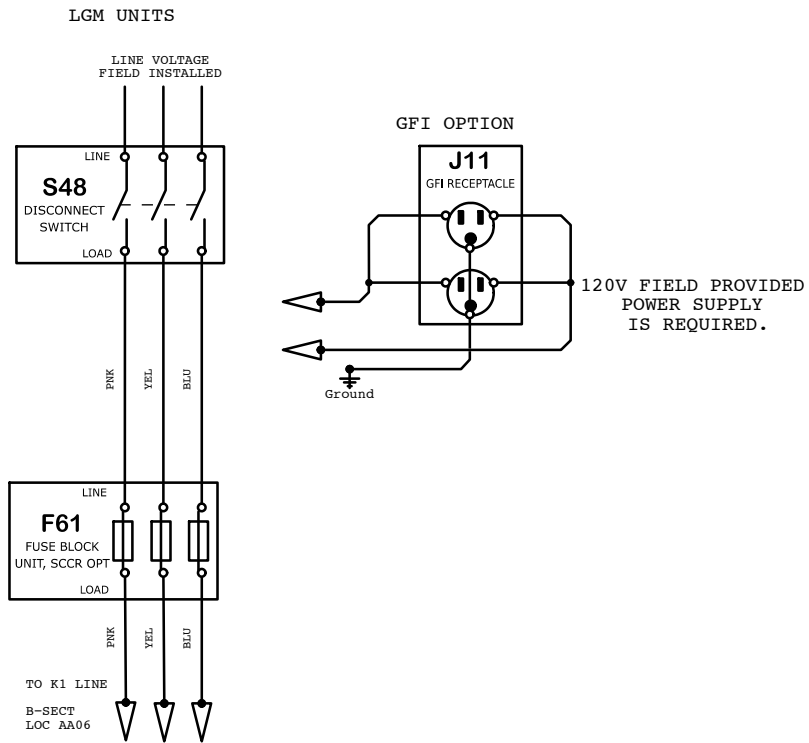

Model: LG, LD Series RTU WITH SCCR
 Power Entry Options 024 - 074
 Voltage: All Voltages
 Supersedes: N/A Form No: 538113-0 Rev: 1

