

INSTALLATION INSTRUCTIONS

⚠ WARNING

To prevent serious injury or death:

- 1- Lock-out/tag-out before performing maintenance.
- 2- If system power is required (e.g., smoke detector maintenance), disable power to blower, remove fan belt where applicable, and ensure all controllers and thermostats are set to the OFF position before performing maintenance.
- 3- Always keep hands, hair clothing, jewelry, tools, etc., away from moving parts.

Table of Contents

Dimensions	2
Parts Arrangement	4
Shipping and Packing List	5
General	5
Safety	5
Unit Support	6
Duct Connection	7
Rigging Unit for Lifting	7
Condensate Drains	7
Connect Gas Piping (Gas Units)	9
Pressure Test Gas Piping (Gas Units)	10
High Altitude Derate	11
Download Mobile Service App	11
Electrical Connections - Power Supply	12
Electrical Connections - Control Wiring	12
Blower Operation	14
Direct Drive Blower Start-Up	16
Cooling Start-Up	19

LHT/LDT078	(6.5 Ton)
LHT/LDT092	(7.5 Ton)
LHT/LDT102	(8.5 Ton)
LHT/LDT122	(10 Ton)
LHT/LDT150	(12.5 Ton)

PACKAGED UNITS

508320-01
 3/2024
 Supersedes 11/2023

⚠ WARNING

Improper installation, adjustment, alteration, service or maintenance can cause property damage, personal injury or loss of life. Installation and service must be performed by a licensed professional HVAC installer or equivalent, service agency, or the gas supplier

Cooling Start-Up	21
Heating Start-Up (LDT)	24
Heating Operation and Adjustments	26
Electric Heat Start-Up (LHT Units)	26
Cooling Operation	27
Service	28
Field-Installed Accessories	35
Unit Controller Parameter Settings	35

RETAIN THESE INSTRUCTIONS FOR FUTURE REFERENCE

Attention!

Use this QR code to download the mobile service app. Follow the prompts to pair the app with the unit control system and configure the unit. Refer to the “Download Mobile App” section in this manual and the Setup Guide provided with this unit. The QR code is also available in the unit control area.



The app can be downloaded from the appropriate iOS or Android store. Look for the following icon.



⚠ CAUTION

As with any mechanical equipment, contact with sharp sheet metal edges can result in personal injury. Take care while handling this equipment and wear gloves and protective clothing.

LHT/LDT078, 092, 102H DIMENSIONS - GAS HEAT SECTION SHOWN

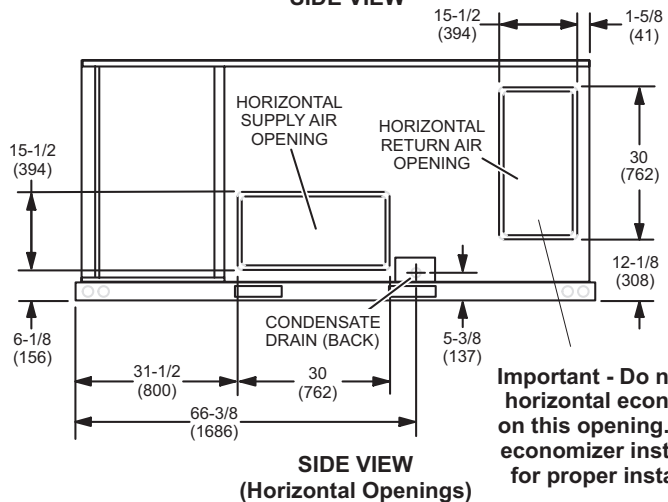
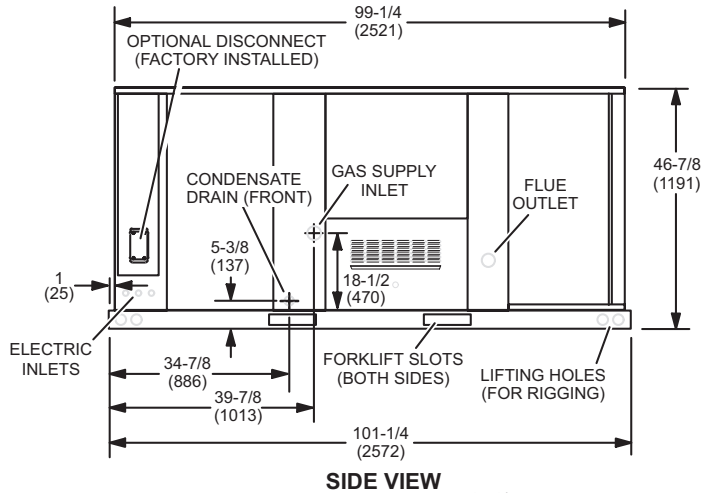
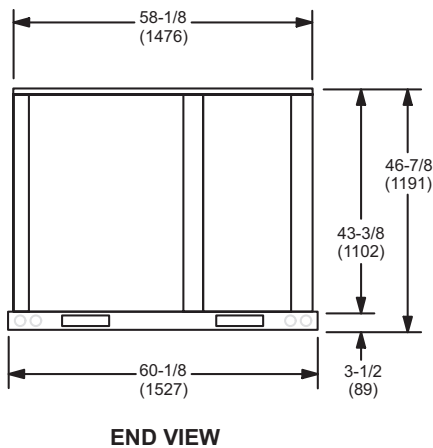
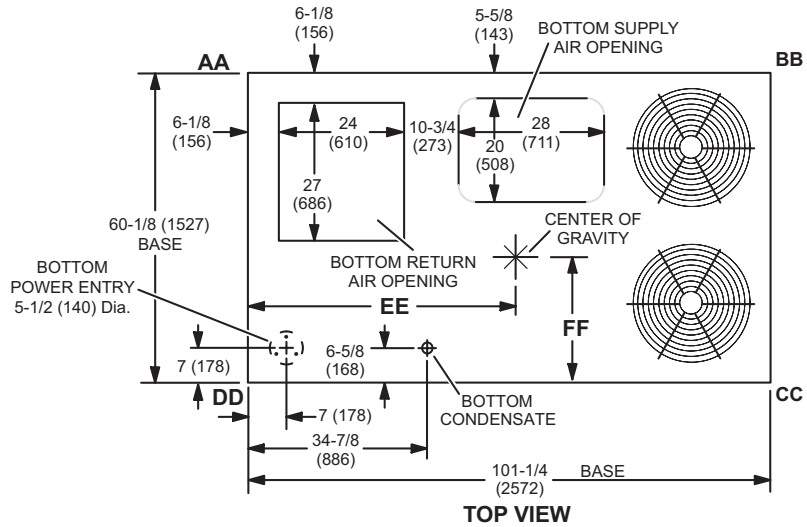

Important - Do not install horizontal economizers on this opening. Refer to economizer instructions for proper installation.

LHT/LDT122, 150H DIMENSIONS - GAS HEAT SECTION SHOWN

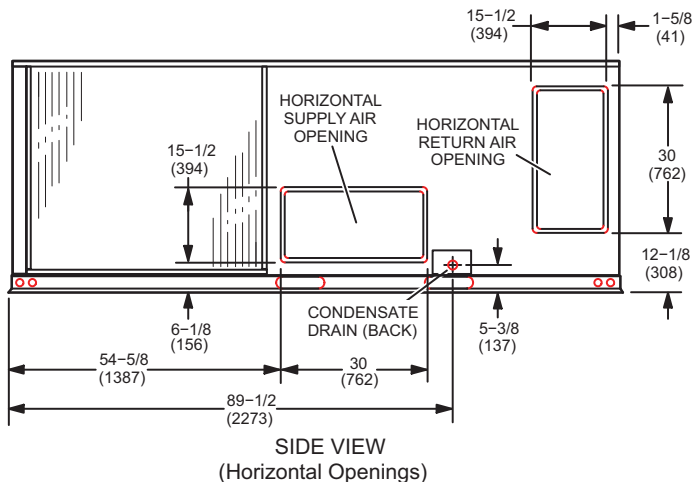
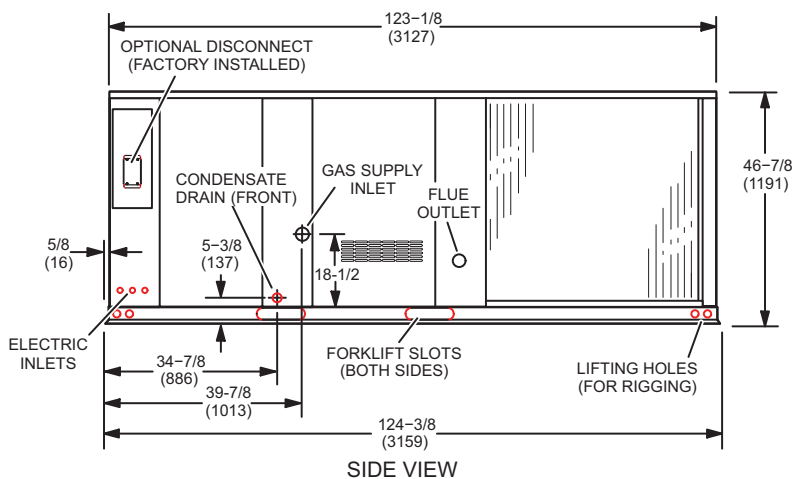
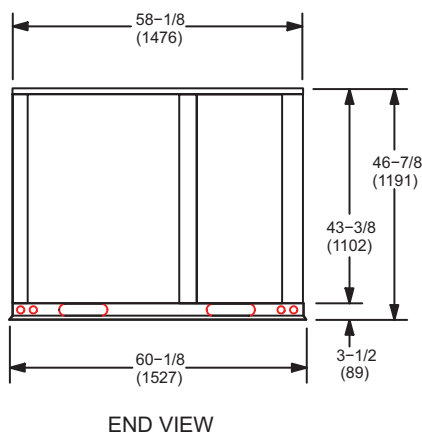
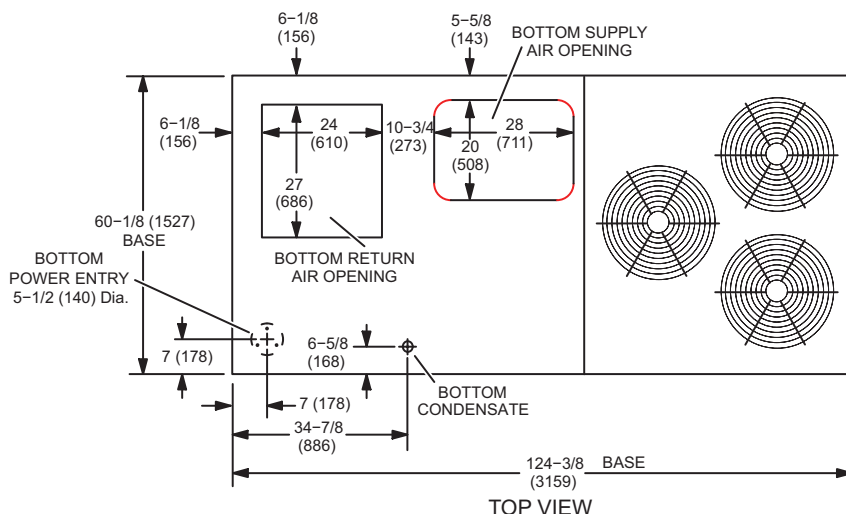

LHT078, 092, 102, 122, 150 PARTS ARRANGEMENT

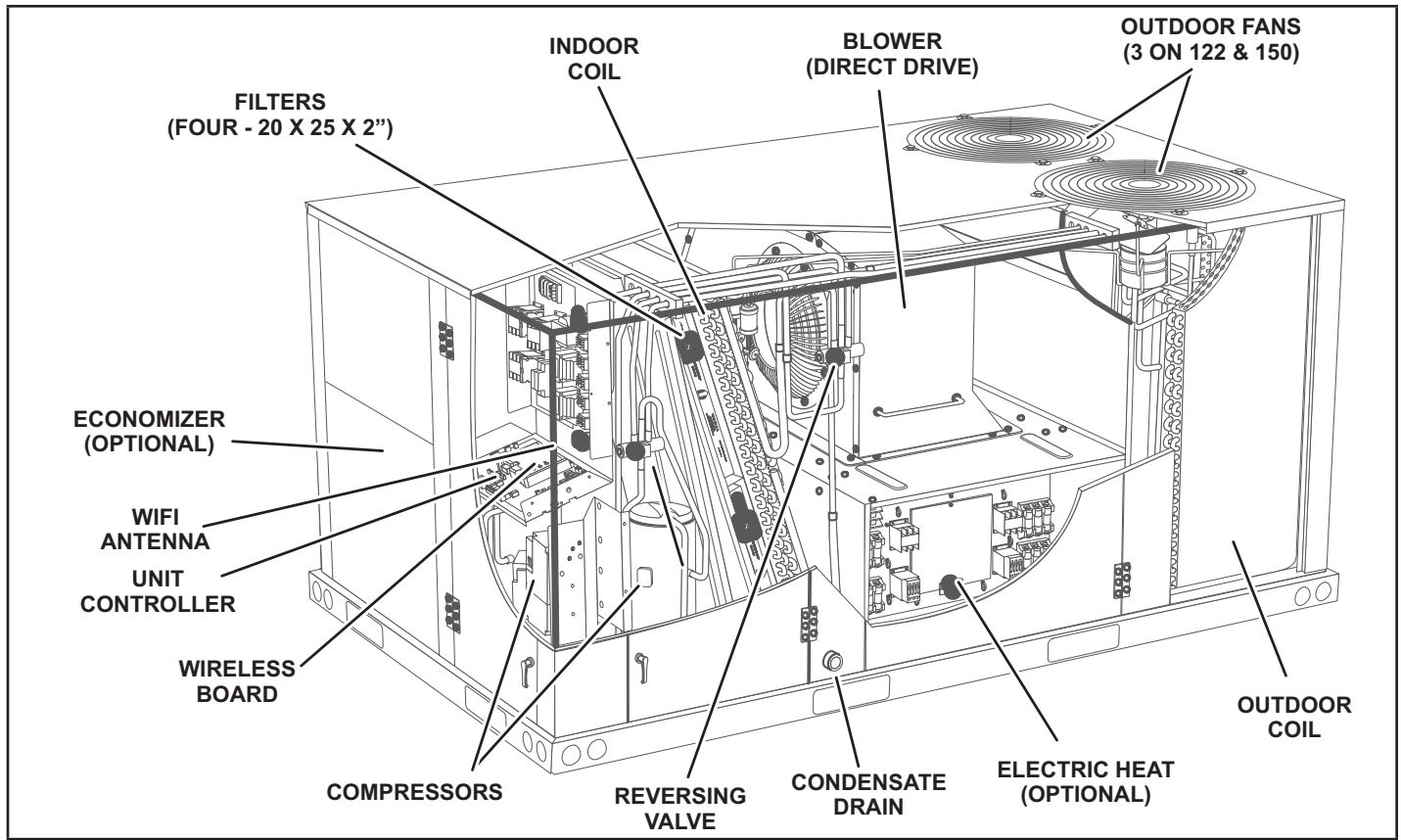

LDT078, 092, 102, 122, 150 PARTS ARRANGEMENT

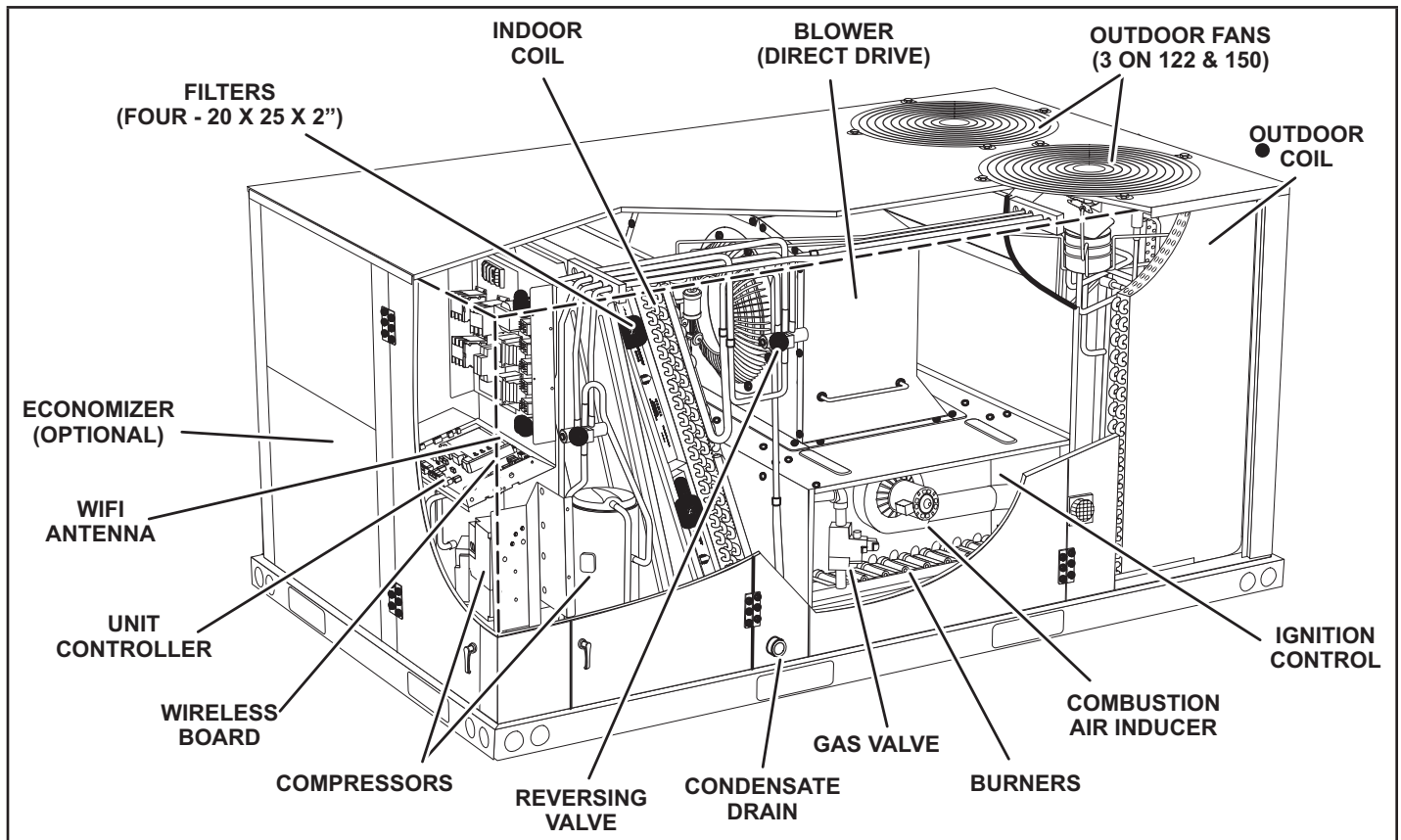

Shipping and Packing List

Package 1 of 1 contains:

- 1 - Assembled unit

Check unit for shipping damage. Receiving party should contact last carrier immediately if shipping damage is found.

General

These instructions are intended as a general guide and do not supersede local codes in any way. Authorities having jurisdiction should be consulted before installation.

The LDT078, 092, 102, 122, & 150H heat pump/gas heating (dual-fuel) packaged rooftop unit is available in 130,000, 180,000, or 240,000 Btuh heating inputs.

The LHT078, 092, 102, 122, & 150 heat pump packaged rooftop unit is the same basic design as the LDT unit except for the heating section. Optional electric heat is factory- or field-installed in LHT units.

Units are equipped with fin/tube outdoor coils.

Units are equipped with direct drive blowers. The blower will operate at lower speeds when demand is low and increase to higher speeds when demand is high. Refer to the Direct Drive Start-Up section.

The following examples show the model numbers of ten ton units with blower options.

LHT/LDT122H4E

Single Zone Staged Direct Drive

All units are available using R410A, an ozone-friendly HFC refrigerant. Refer to the Cooling Start-Up section for precautions when installing unit.

Safety

See TABLE 1 for clearances.

⚠ WARNING



Electric shock hazard and danger of explosion. Can cause injury, death or product or property damage. Turn off gas and electrical power to unit before performing any maintenance or servicing operations on the unit. Follow lighting instructions attached to unit when putting unit back into operation and after service or maintenance.

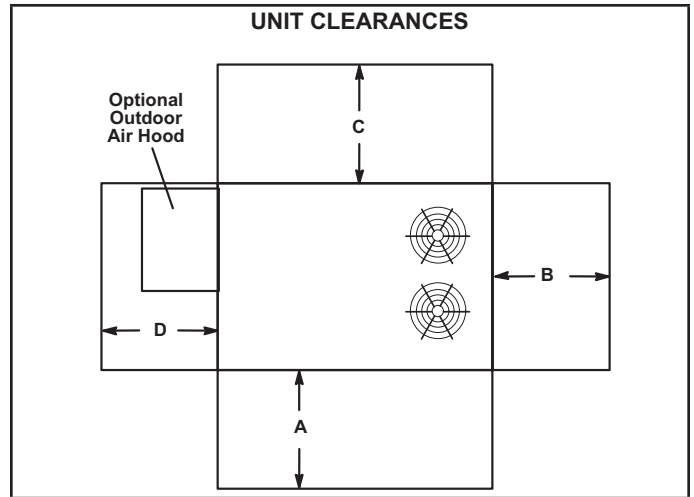

FIGURE 1

TABLE 1 UNIT CLEARANCES					
¹ Unit Clearance	A in.(mm)	B in.(mm)	C in.(mm)	D in.(mm)	Top Clearance
Service Clearance	60 (1524)	36 (914)	36 (914)	66 (1676)	Unob- structed
Clearance to Combustibles	36 (914)	1 (25)	1 (25)	1 (25)	Unob- structed
Minimum Operation Clearance	36 (914)	36 (914)	36 (914)	41 (1041)	Unob- structed

NOTE - Entire perimeter of unit base requires support when elevated above mounting surface.

¹**Service Clearance** - Required for removal of serviceable parts

Clearance to Combustibles - Required clearance to combustible material (gas units).

Minimum Operation Clearance - Required clearance for proper unit operation.

⚠ NOTICE

Roof Damage!

This system contains both refrigerant and oil. Some rubber roofing material may absorb oil, causing the rubber to swell. Bubbles in the rubber roofing material can cause leaks. Protect the roof surface to avoid exposure to refrigerant and oil during service and installation. Failure to follow this notice could result in damage to roof surface.

⚠ IMPORTANT

The Clean Air Act of 1990 bans the intentional venting of refrigerant (CFC's and HCFC's) as of July 1, 1992. Approved methods of recovery, recycling or reclaiming must be followed. Fines and/or incarceration may be levied for non-compliance.

The LHT/LDT unit is ETL/CSA certified for outdoor installations only at the clearances to combustible materials listed on unit nameplate and in FIGURE 1.

Installation of LHT/LDT heat pumps must conform with standards in National Fire Protection Association (NFPA) "Standard for Installation of Air Conditioning and Ventilating Systems NFPA No. 90A," "Standard for Installation of Residence Type Warm Air Heating and Air conditioning Systems NFPA No. 90B," local municipal building codes and manufacturer's installation instructions.

The National Electric Code (ANSI/NFPA No. 70-1984) is available from:

National Fire Protection Association 1
Batterymarch Park
PO Box 9101
Quincy, MA 02269-9101

The LDT unit is ETL/CSA certified as a heat pump with cooling and auxiliary gas heat for non-residential use only at the clearances to combustible materials as listed on the unit nameplate and in FIGURE 1.

Installation of ETL/CSA certified units must conform with current standard C273.5 "Installation Requirements for Heat Pumps" and applicable local codes. Authorities having jurisdiction should be consulted before installation.

Use of this unit as a construction heater or air conditioner is not recommended during any phase of construction. Very low return air temperatures, harmful vapors and operation of the unit with clogged or misplaced filters will damage the unit.

If this unit has been used for heating or cooling of buildings or structures under construction, the following conditions must be met or the warranty will be void:

- A room thermostat or zone air temperature sensor must control the unit. The use of fixed jumpers that will provide continuous heating or cooling is not allowed.
- A pre-filter must be installed at the entry to the return air duct.
- The return air duct must be provided and sealed to the unit.
- Return air temperature range between 55°F (13°C) and 80°F (27°C) must be maintained.
- Air filters must be replaced and pre-filters must be removed upon construction completion.
- The input rate and temperature rise must be set per the unit rating plate.
- The heat exchanger, components, duct system, air filters and indoor coil must be thoroughly cleaned following final construction clean-up.
- The unit operating conditions (including airflow, cooling operation, ignition, input rate, temperature rise and venting) must be verified according to these installation instructions.

This appliance is not to be used by persons with reduced physical, sensory or mental capabilities, or lack of experience and knowledge, unless they have been given supervision or instruction.

This appliance should not be used by children. Children should be supervised to ensure they do not play with the appliance.

Unit Support

In downflow discharge installations, install the unit on a non-combustible surface only. Unit may be installed on combustible surfaces when used in horizontal discharge applications or in downflow discharge applications when installed on an C1CURB7*B roof mounting frame.

NOTE - Securely fasten roof frame to roof per local codes.

CAUTION

To reduce the likelihood of supply / return air by pass and promote a proper seal with the RTU, duct work / duct drops / diffuser assemblies must be supported independently to the building structure.

A-Downflow Discharge Application

Roof Mounting with C1CURB7*B

- 1 - The C1CURB7*B roof mounting frame must be installed, flashed and sealed in accordance with the instructions provided with the frame.
- 2 - The C1CURB7*B roof mounting frame should be square and level to 1/16" per linear foot (5mm per linear meter) in any direction.
- 3 - Duct must be attached to the roof mounting frame and not to the unit; supply and return plenums must be installed before setting the unit.

Installer's Roof Mounting Frame

Many types of roof frames can be used to install the unit depending upon different roof structures. Items to keep in mind when using the building frame or supports are:

- 1 - The base is fully enclosed and insulated, so an enclosed frame is not required.
- 2 - The frames or supports must be constructed with non-combustible materials and should be square and level to 1/16" per linear foot (5mm per linear meter) in any direction.
- 3 - Frame or supports must be high enough to prevent any form of moisture from entering unit. Recommended minimum frame height is 14" (356mm).

- 4 - Duct must be attached to the roof mounting frame and not to the unit. Supply and return plenums must be installed before setting the unit.
- 5 - Units require support along all four sides of unit base. Supports must be constructed of steel or suitably treated wood materials.

NOTE - When installing a unit on a combustible surface for downflow discharge applications, an C1CURB7*B roof mounting frame is required.

B-Horizontal Discharge Applications

- 1 - Units installed in horizontal airflow applications must use a horizontal conversion kit K1HECK00.
- 2 - Specified installation clearances must be maintained when installing units. Refer to FIGURE 1.
- 3 - Top of support slab should be approximately 4" (102mm) above the finished grade and located so no run-off water from higher ground can collect around the unit.
- 4 - Units require support along all four sides of unit base. Supports must be constructed of steel or suitably treated wood materials.

Duct Connection

All exterior ducts, joints and openings in roof or building walls must be insulated and weather-proofed with flashing and sealing compounds in accordance with applicable codes. Any duct passing through an unconditioned space must be insulated.

⚠ CAUTION

In downflow applications, do not drill or punch holes in base of unit. Leaking in roof may occur if unit base is punctured.

Rigging Unit for Lifting

Rig unit for lifting by attaching four cables to holes in unit base rail. See FIGURE 2.

- 1 - Detach wooden base protection before rigging.

NOTE - Remove all 7 (5 brackets on units with three outdoor fans) base protection brackets before setting unit.
- 2 - Connect rigging to the unit base using both holes in each corner.
- 3 - All panels must be in place for rigging.
- 4 - Place field-provided H-style pick in place just above top edge of unit. Frame must be of adequate strength and length. (H-style pick prevents damage to unit.)

Condensate Drains

Make drain connection to the 1" N.P.T. drain coupling provided on unit.

NOTE - The drain pan is made with a glass reinforced engineered plastic capable of withstanding typical joint torque but can be damaged with excessive force. Tighten pipe nipple hand tight and turn an additional quarter turn.

A trap must be installed between drain connection and an open vent for proper condensate removal. See FIGURE 3 or FIGURE 4. It is sometimes acceptable to drain condensate onto the roof or grade; however, a tee should be fitted to the trap to direct condensate downward. The condensate line must be vented. Check local codes concerning condensate disposal. Refer to page 1 and page 2 for condensate drain location.

RIGGING

Unit	*Weight	
	Lbs.	Kg.
078-150	1514	687

*Maximum weight with all available factory-installed accessories.

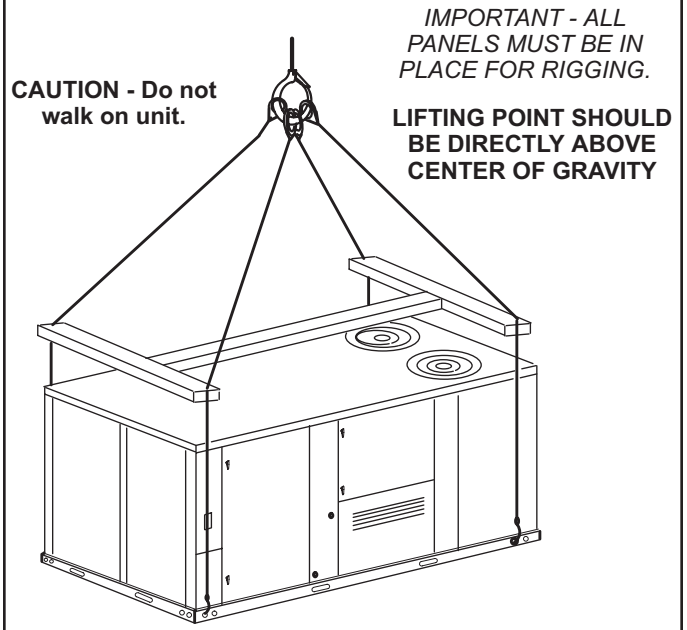

FIGURE 2

CONDENSATE SIDE DRAIN CONNECTION

CAULK AROUND CONDENSATE COUPLING

NOTE - Allow clearance to open doors when installing condensate piping.

Minimum Pitch
1" (25 mm) per
10' (3 m) of line

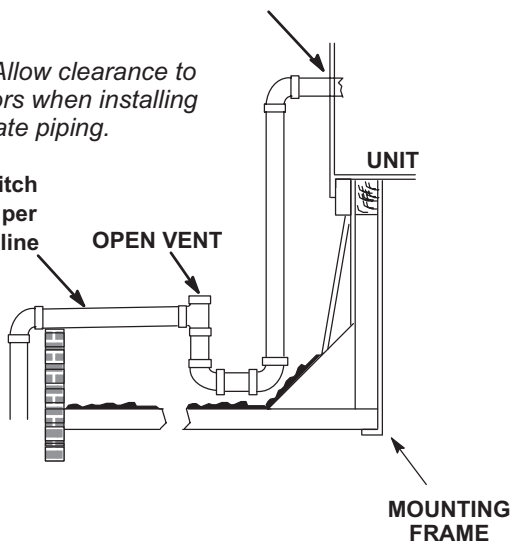

FIGURE 3

CONDENSATE BOTTOM DRAIN CONNECTION

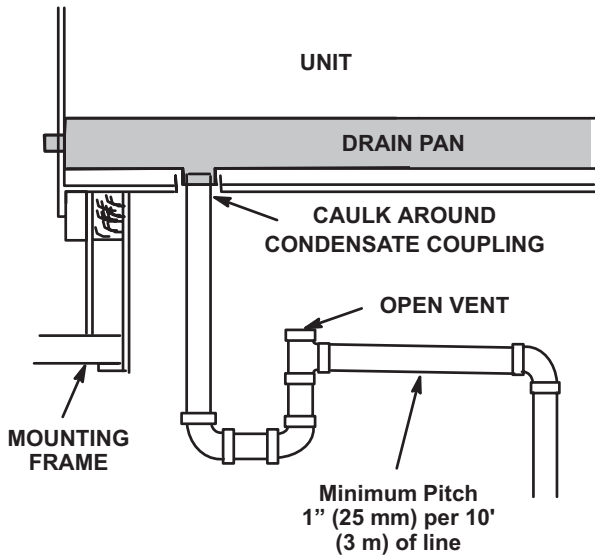

FIGURE 4

Units are shipped with the drain coupling facing the front of the unit. Condensate can be drained from the back or bottom of the unit with the following modifications. The unit can be installed in either downflow or horizontal air discharge regardless of condensate drain location.

Rear Drain Connection

1 - Open blower and heat access doors. See FIGURE 5.

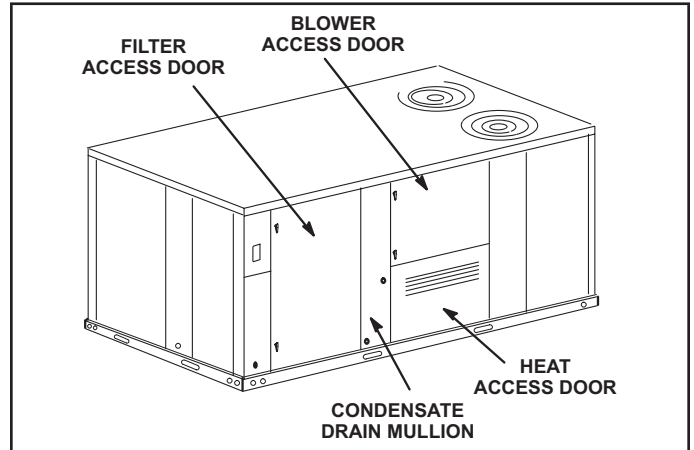

FIGURE 5

2 - Remove six screws from filter access door. Refer to FIGURE 6.

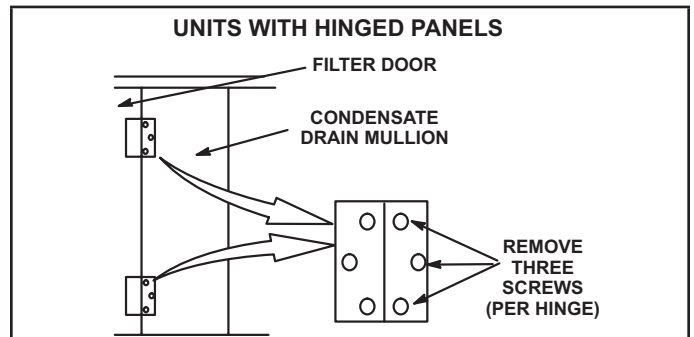

FIGURE 6

- 3 - Open filter access door hinges and carefully remove door.
- 4 - Remove eight screws holding condensate drain mullion and remove mullion.
- 5 - Lift front edge of the drain pan (to clear bottom drain plug) and slide drain pan out of unit. See FIGURE 7.

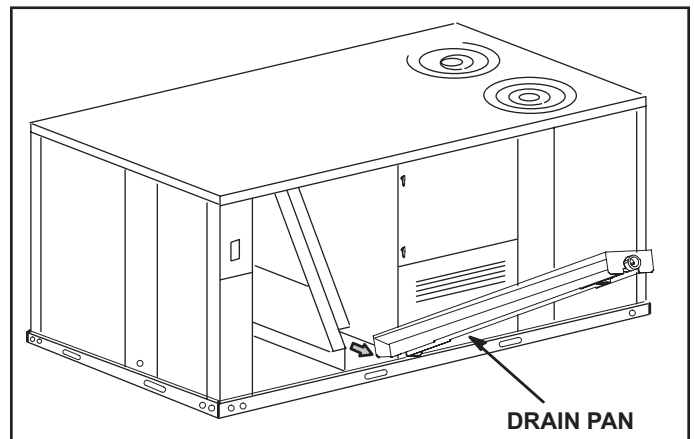

FIGURE 7

- 6 - Make sure the cap over the unit bottom drain hole is secure.
- 7 - Rotate the drain pan until the downward slope is toward the back of the unit. Slide the drain pan back into the unit. Be careful not to dislodge the cap over the bottom drain hole.
- 8 - From the back side of the unit, pull the drain pan coupling through the rear condensate opening.
- 9 - Replace the condensate drain mullion and reinstall eight screws.
- 10 - Reinstall filter door on hinges.

Bottom Drain Connection

- 1 - Open blower and heat access doors. See FIGURE 5.
- 2 - Remove six screws from filter access door. Refer to FIGURE 6.
- 3 - Open filter access door hinges and carefully remove door.
- 4 - Remove eight screws holding condensate drain mullion and remove mullion.
- 5 - Lift front edge of the drain pan (to clear bottom drain plug) and slide drain pan out of unit. See FIGURE 7.
- 6 - Turn the drain pan upside down and drill a pilot hole through the bottom of the drain pan in the center of the coupling. See FIGURE 8.

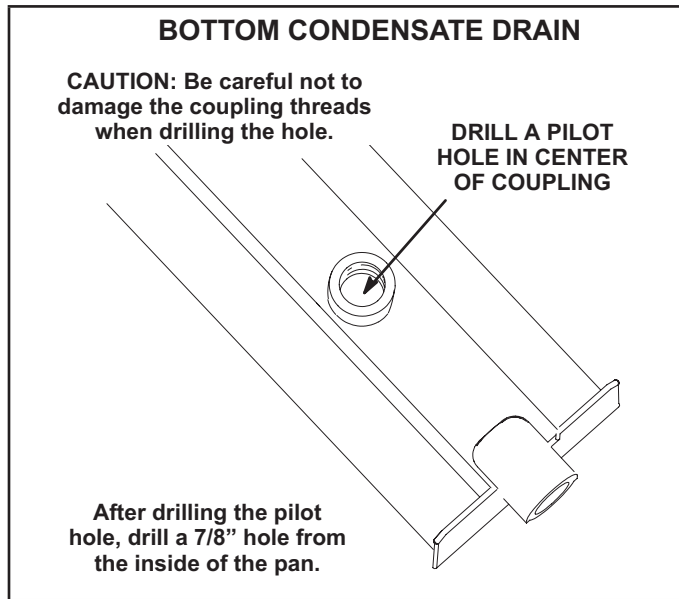

FIGURE 8

- 7 - From the inside of the pan, use a Vari-Bit® bit to enlarge the hole to 7/8". Do not damage coupling threads.
- 8 - Remove the cap over the unit bottom drain hole.
- 9 - Slide the drain pan back into the unit.
- 10 - From the back side of the unit, pull the drain pan coupling through the rear condensate opening.
- 11 - From the front side of the unit, move the drain pan until the bottom coupling settles into the unit bottom drain opening. Once in place, check to make sure the coupling is still positioned through the rear condensate drain hole.
- 12 - Use a field-provided 1" plug to seal side drain connection.
- 13 - Replace the condensate drain mullion and reinstall eight screws.
- 14 - Reinstall filter door on hinges.

Connect Gas Piping (Gas Units)

Before connecting piping, check with gas company or authorities having jurisdiction for local code requirements. When installing gas supply piping, length of run from gas meter must be considered in determining pipe size for 0.5" w.c. (.12kPa) maximum pressure drop. Do not use supply pipe smaller than unit gas connection. For natural gas units, operating pressure at the unit gas connection must be a minimum of 4.7" w.c. (1.17kPa) and a maximum of 10.5" (2.60kPa) w.c. For LP/propane gas units, operating pressure at the unit gas connection must be a minimum of 10.5" w.c. (2.61kPa) and a maximum of 13.0" w.c. (3.23kPa).

When making piping connections a drip leg should be installed on vertical pipe runs to serve as a trap for sediment or condensate. A 1/8" N.P.T. plugged tap is located on gas valve for test gauge connection. Refer to Heating Start-Up section for tap location. Install a ground joint union between the gas control manifold and the main manual shut-off valve. See FIGURE 9 for gas supply piping entering outside the unit. FIGURE 10 shows bottom gas entry piping through the curb. FIGURE 11 shows bottom gas entry piping through the unit.

Compounds used on threaded joints of gas piping shall be resistant to the action of liquefied petroleum gases.

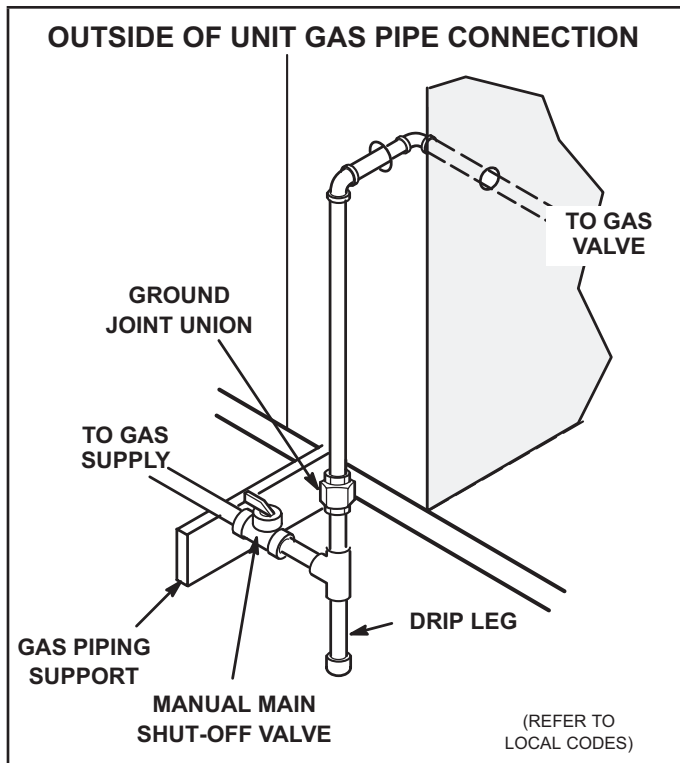

FIGURE 9

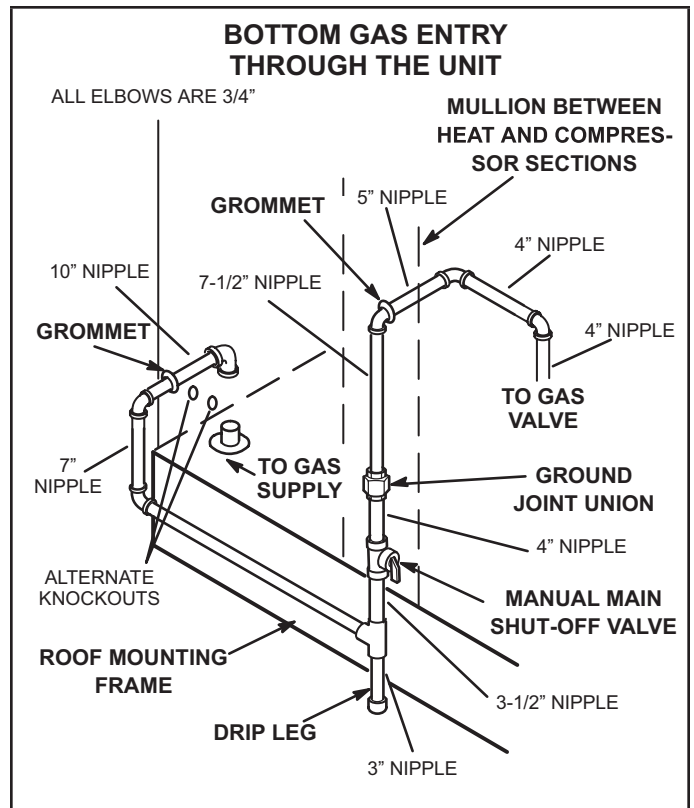

FIGURE 11

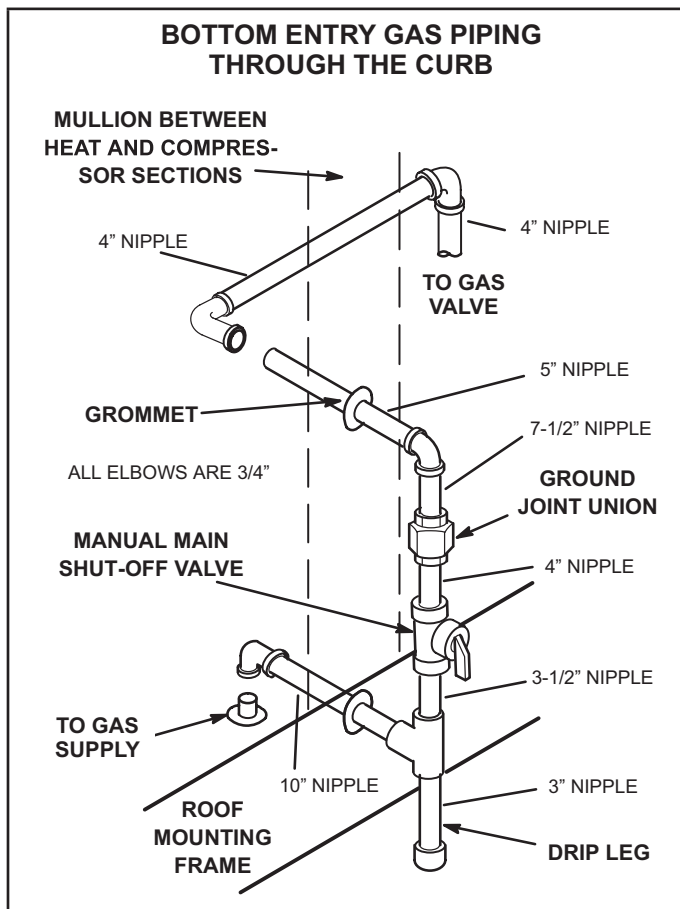

FIGURE 10

Pressure Test Gas Piping (Gas Units)

When pressure testing gas lines, the gas valve must be disconnected and isolated. Gas valves can be damaged if subjected to more than 0.5 psig (3.48kPa). See FIGURE 12.

NOTE - Codes may require that manual main shut-off valve and union (furnished by installer) be installed in gas line external to unit. Union must be of the ground joint type.

After all connections have been made, check all piping connections for gas leaks. Also check existing unit gas connections up to the gas valve; loosening may occur during installation. Use a leak detection solution or other preferred means. Do not use matches candles or other sources of ignition to check for gas leaks.

NOTE - In case emergency shut down is required, turn off the main manual shut-off valve and disconnect main power to unit. These devices should be properly labeled by the installer.

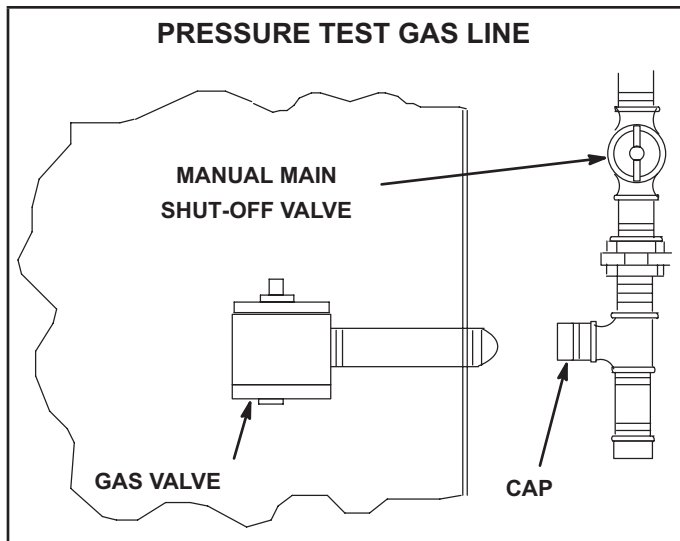

FIGURE 12

⚠ CAUTION

Some soaps used for leak detection are corrosive to certain metals. Carefully rinse piping thoroughly after leak test has been completed. Do not use matches, candles, flame or other sources of ignition to check for gas leaks.

⚠ WARNING



Danger of explosion. Can cause injury or product or property damage. Do not use matches, candles, flame or other sources of ignition to check for leaks.

High Altitude Derate

Locate the high altitude conversion sticker in the unit literature bag. Fill out the conversion sticker and affix next to the unit nameplate. High altitude kits are available for field-installation.

Refer to TABLE 2 for high altitude adjustments.

TABLE 2

Altitude Ft.*	Gas Manifold Pressure
2000-4500	See Unit Nameplate
4500 and Above	Derate 4% / 1000 Ft. above Sea Level

*Units installed at 0-2000 feet do not need to be modified

NOTE - This is the only permissible derate for these units.

Download Mobile Service App

A-Mobile Device Requirements

- Android hardware requires 2GB RAM and a 2Ghz core processor. Tablets are supported.
- Minimum Android 6.0 (Marshmallow) or higher. Recommend Android 10 and Apple products require iOS version 11 or higher.

B-New Installations

Once the app is downloaded, refer to the Setup Guide provided with this unit to pair the app to the unit control system. Follow the setup wizard prompts to configure the unit. See FIGURE 13 for the app menu overview. If a mobile device is unavailable or not pairing, refer to the Unit Controller Setup Guide for start-up instructions.

MOBILE SERVICE APP MENU OVERVIEW

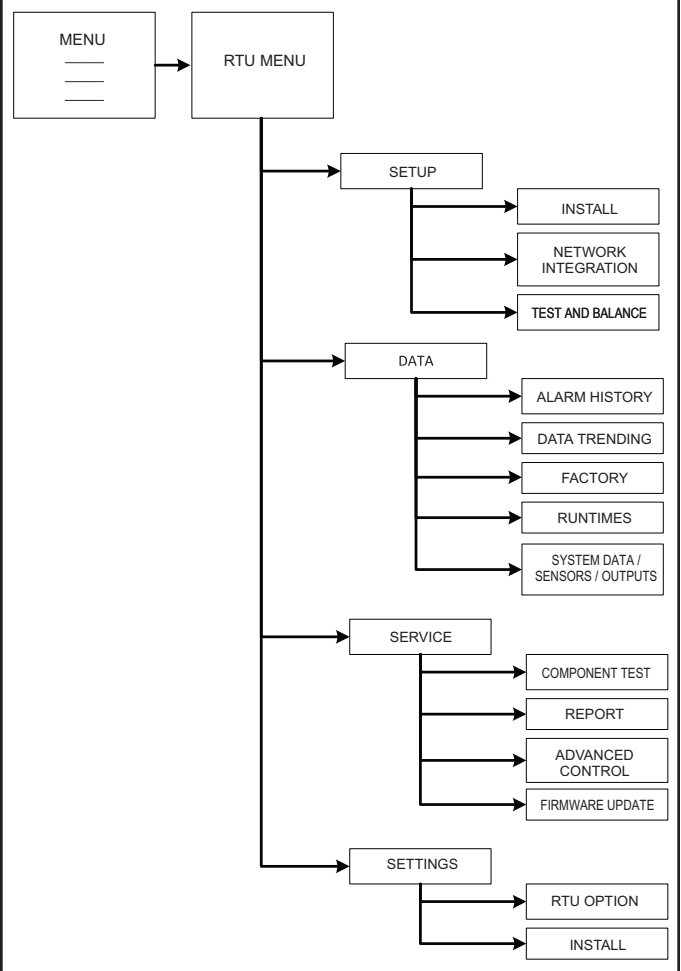

FIGURE 13

Electrical Connections - Power Supply

Route field wiring in conduit between bottom power entry disconnect. See FIGURE 14. This does not supersede local codes or authorities having jurisdiction.

Do not apply power or close disconnect switch until installation is complete. Refer to start-up directions. Refer closely to unit wiring diagram.

Refer to unit nameplate for minimum circuit ampacity and maximum fuse size.

- 1 - 230/460/575 volt units are factory wired. For **208V supply**, disconnect the orange wire (230V) at all control power transformer(s). Reconnect the red wire (208V). Tape the exposed end of the 230V orange wire.
- 2 - Route power through the bottom power entry area. On gas units or units with electric heat, connect power wiring to TB2. On cooling only units, connect power to F4. If unit contains an optional factory-installed circuit breaker or disconnect switch, connect line voltage to CB10 or S48. See unit wiring diagram.
- 3 - Connect separate 120v wiring to optional field-powered GFCI outlet. Route field wiring in conduit between bottom power entry and GFCI. See FIGURE 14. For unit-powered GFCI, no additional field wiring is required.

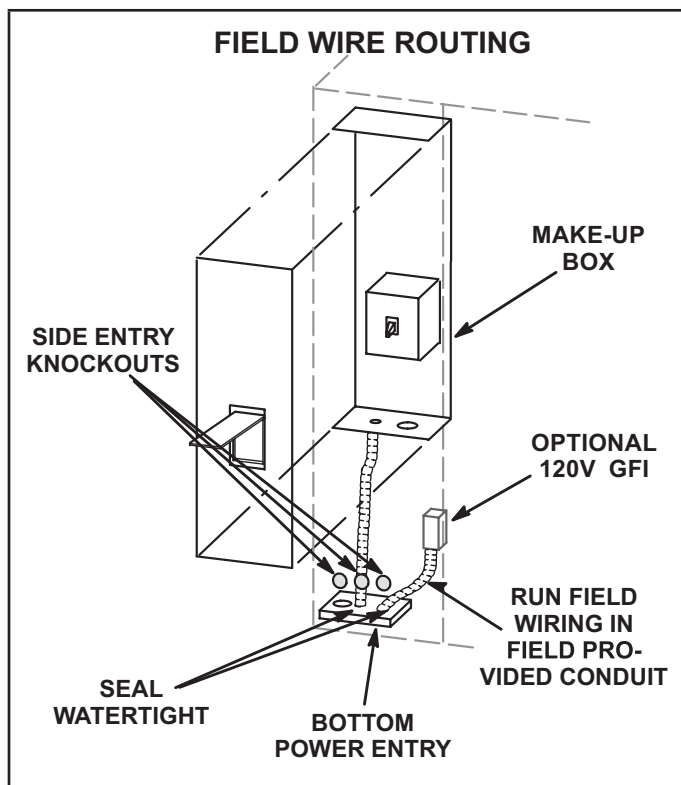

FIGURE 14

Electrical Connections - Control Wiring

NOTE - Optional wireless sensors are available for use with this unit. Refer to the instructions provided with each sensor.

⚠ CAUTION

Electrostatic discharge can affect electronic components. Take precautions during unit installation and service to protect the electronic controls. Precautions will help to avoid control exposure to electrostatic discharge by putting the unit, the control and the technician at the same electrostatic potential. Neutralize electrostatic charge by touching hands and all tools on an unpainted unit surface, such as the gas valve or blower deck, before performing any service procedure.

A-Thermostat Location

Applied to units in default thermostat control mode only. Room thermostat mounts vertically on a standard 2" X 4" handy box or on any non-conductive flat surface.

Locate thermostat approximately 5 feet (1524mm) above the floor in an area with good air circulation at average temperature. Avoid locating the room thermostat where it might be affected by:

- drafts or dead spots behind doors and in corners
- hot or cold air from ducts
- radiant heat from sun or appliances
- concealed pipes and chimneys

IMPORTANT - Unless field thermostat wires are rated for maximum unit voltage, they must be routed away from line voltage wiring.

B-Control Wiring

The Unit Controller will operate the unit from a thermostat or zone sensor based on the System Mode. The default System Mode is the thermostat mode. Refer to the Unit Controller Setup Guide to change the System Mode. Use the mobile service app menu and select Settings > Install.

Thermostat Mode

- 1 - Route thermostat cable or wires from subbase to control area above compressor (refer to unit dimensions to locate bottom and side power entry).

IMPORTANT - Unless field thermostat wires are rated for maximum unit voltage, they must be routed away from line voltage wiring. Use wire ties located near the lower left corner of the controls mounting panel to secure thermostat cable.

Use 18 AWG wire for all applications using remotely installed electro-mechanical and electronic thermostats.

- 2 - Install thermostat assembly in accordance with instructions provided with thermostat.

- 3 - Connect thermostat wiring to Unit Controller on the lower side of the controls hat section.
- 4 - Wire as shown in FIGURE 15 for electro-mechanical and electronic thermostats. If using other temperature control devices or energy management systems see instructions and wiring diagram provided by manufacturer.

IMPORTANT - Terminal connections at the Unit Controller must be made securely. Loose control wire connections may allow unit to operate but not with proper response to room demand.

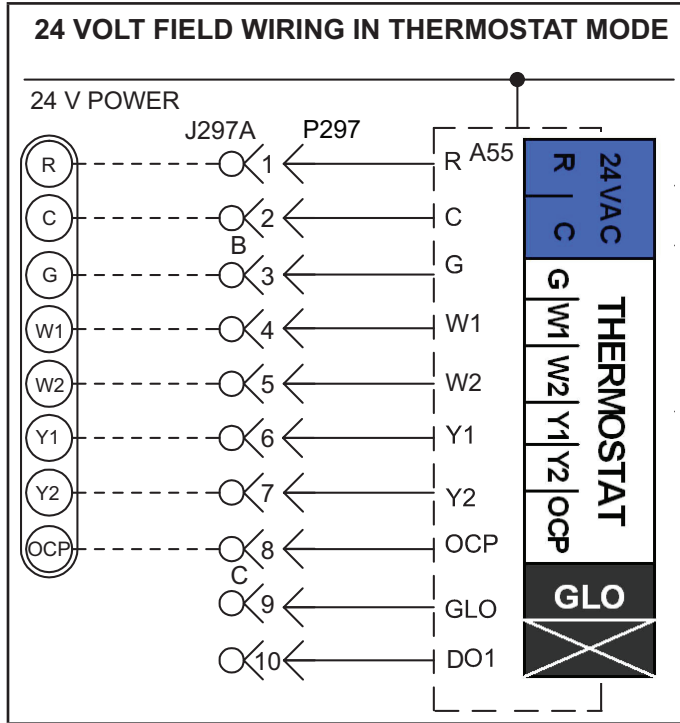

FIGURE 15

Zone Sensor Mode

The Unit Controller will operate heating and cooling based on the Unit Controller internal setpoints and the temperature from the A2 room sensor. An optional Network Control Panel (NCP) can also be used to provide setpoints. A thermostat or return air sensor can be used as a back-up mode. Make room sensor wiring connections as shown in FIGURE 16.

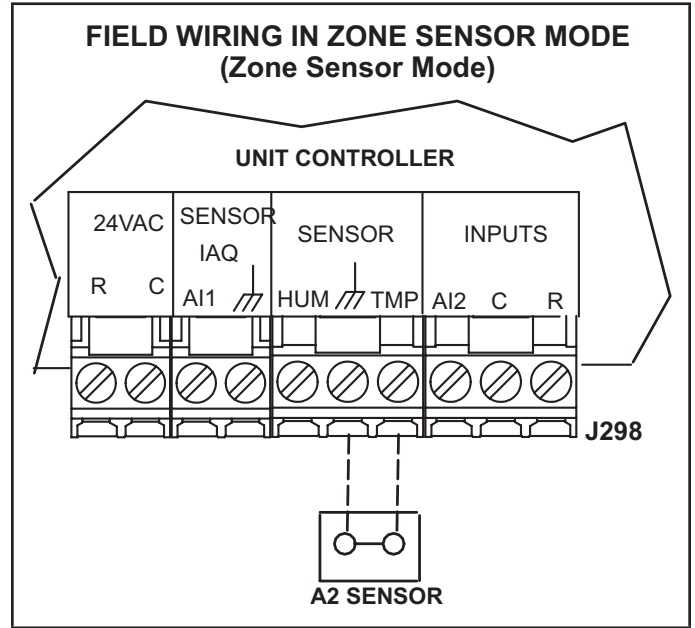

FIGURE 16

Blower Operation

Units are equipped with variable speed, direct drive blowers. The supply CFM can be adjusted by changing the percentage of motor output using the Unit Controller settings. Measure the intake air CFM and adjust the RPM% to get design-specified supply air CFM. Refer to the Direct Drive Blower Start-Up section.

IMPORTANT

Compressor two is the only component that must be checked to ensure proper phasing. Follow "COOLING START-UP" section of installation instructions to ensure proper compressor and blower operation.

The Unit Controller checks the incoming power during start-up. If the voltage or phase is incorrect, the Unit Controller will display an alarm and the unit will not start.

A-Blower Operation

Refer to the Unit Controller Setup Guide to energize blower. Use the mobile service app menu; see:

SERVICE > TEST

In both thermostat and zone control mode, the Unit Controller will stage the blower between low and high speed.

WARNING

- 1- Make sure that unit is installed in accordance with the installation instructions and applicable codes.
- 2- Inspect all electrical wiring, both field and factory-installed, for loose connections. Tighten as required.
- 3- Check to ensure that refrigerant lines do not rub against the cabinet or against other refrigerant lines.
- 4- Check voltage at disconnect switch. Voltage must be within range listed on nameplate. If not, consult power company and have voltage condition corrected before starting unit.
- 5- Make sure filters are new and in place before start-up.

Initiate blower only (G) demand at thermostat according to instructions provided with thermostat. Unit will cycle on thermostat demand. The following steps apply to applications using a typical electro-mechanical thermostat.

- 1 - Blower operation is manually set at the thermostat subbase fan switch. With fan switch in ON position, blowers will operate continuously.
- 2 - With fan switch in AUTO position, the blowers will cycle with demand. Blowers and entire unit will be off when system switch is in OFF position.

NOTE - Blower operation mode can also be initiated by the mobile service app.

Direct-drive motor may not immediately stop when power is interrupted to the Unit Controller. Disconnect unit power before opening the blower compartment. The Controller's digital inputs must be used to shut down the blower. See Unit Controller manual for operation sequences.

B-Blower Access

The blower assembly is secured to a sliding frame which allows the blower assembly to be pulled out of the unit. See FIGURE 18.

- 1 - Loosen the reusable wire tie which secures the controls and high voltage blower wiring to the blower housing. Disconnect the pressure sensor low voltage wire harness.
- 2 - Remove and retain screws on either side (and on the front for direct drive) of sliding frame. Use the metal handle to pull frame toward outside of unit.
- 3 - Slide frame back into original position when finished servicing. Reattach the blower wiring in the previous location using the wire tie. Reconnect pressure sensor low voltage wire harness.
- 4 - Replace retained screws.

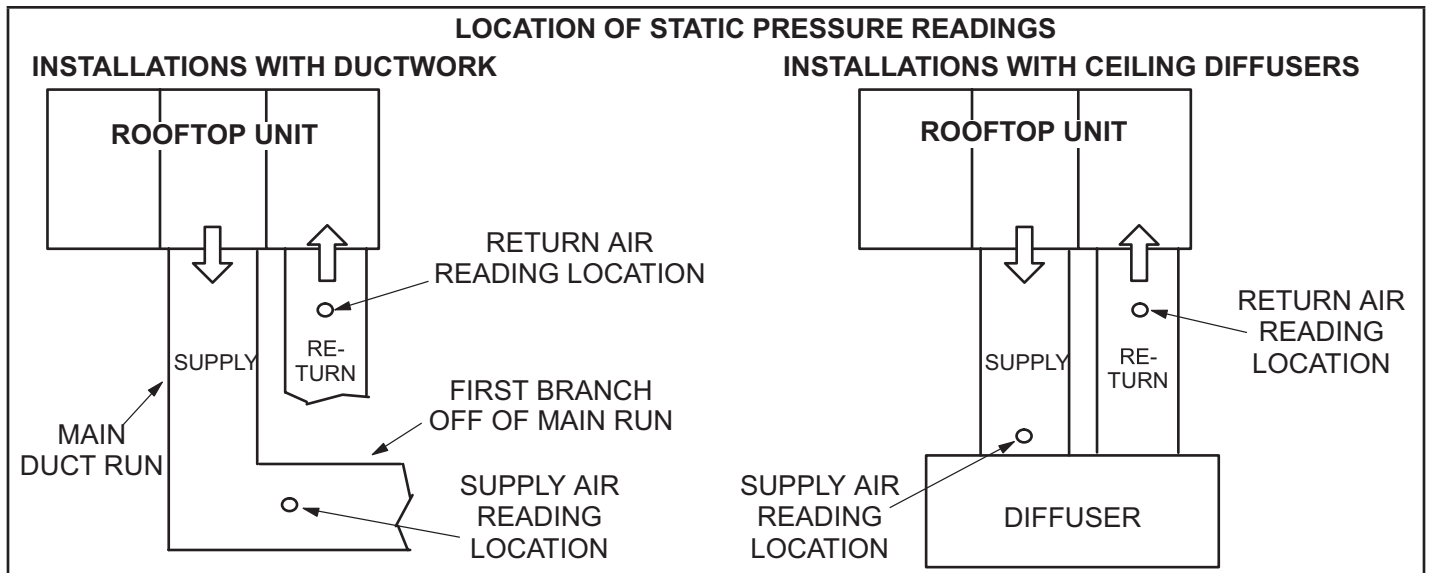

FIGURE 17

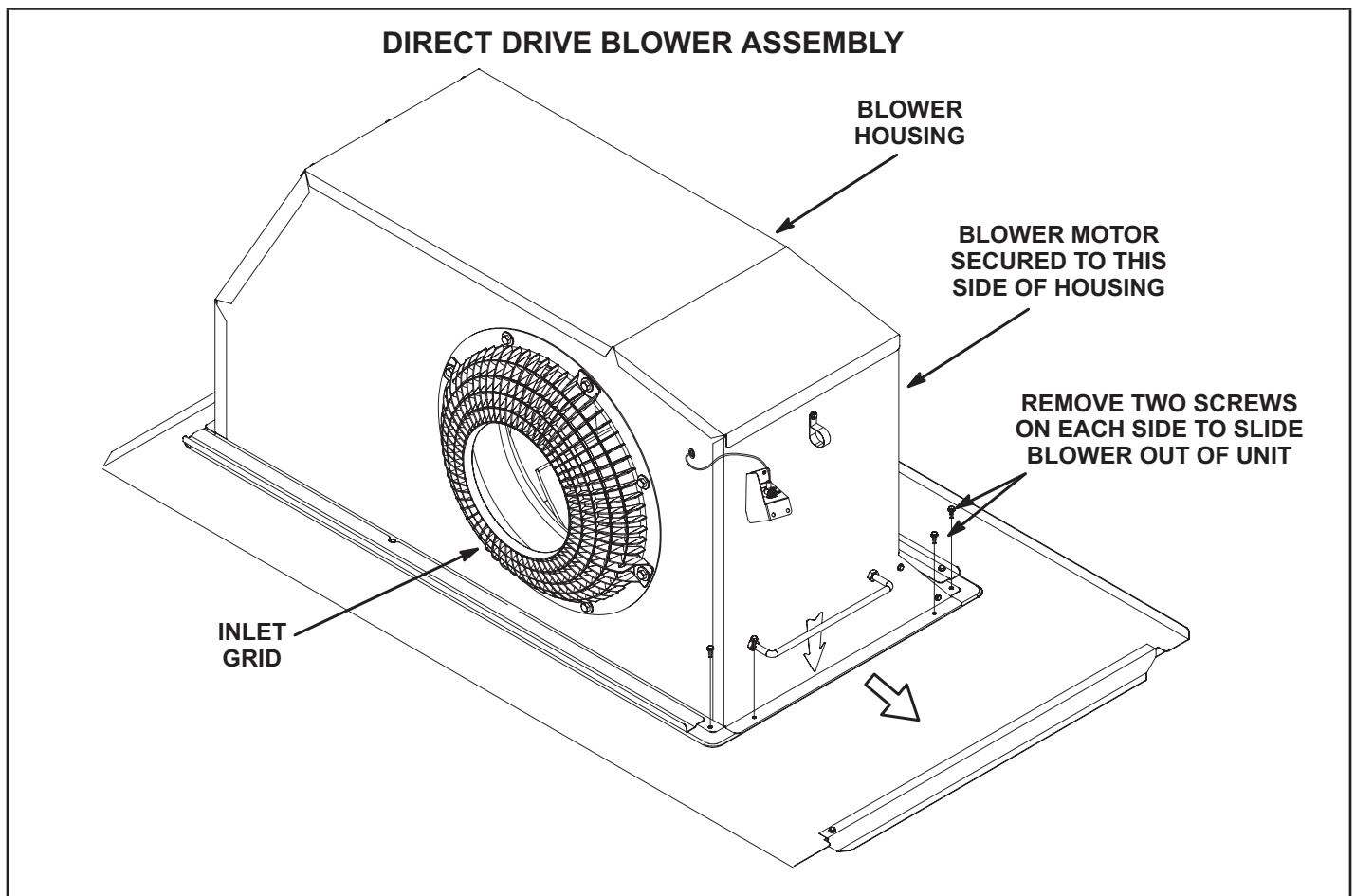

FIGURE 18

Direct Drive Blower Start-Up

The supply CFM can be adjusted by changing the percentage of motor output using the Unit Controller settings. Refer to TABLE 3 for menu paths and default settings. Record any RPM% changes on the parameter settings label located on the inside of the compressor access panel.

IMPORTANT

The BLOWER CALIBRATION process starts the in door blower at operational speeds and moves the economizer damper blades. Before starting this process, replace any access panels and close all unit doors except compressor compartment door.

Blower calibration is required only on units that are newly installed or if there is a change in the duct work or air filters after installation. Use the mobile service app to navigate to the SETUP>TEST & BALANCE>BLOWER menu. After the new CFM values are entered, select START CALIBRATION. The blower calibration status is displayed as a % complete. Upon successful completion, the mobile service app will display CALIBRATION SUCCESS and go back to the blower calibration screen.

IMPORTANT - The default value for Cooling Low CFM is lower than a traditional single- or two-speed unit. If operating the unit with a 2- or 3-stage controller (2- or 3-stage thermostat, DDC controller, etc.), it is recommended to increase the Cooling Low CFM default value to a suitable level for part load cooling (typically 60% of full load CFM).

**TABLE 3
DIRECT DRIVE PARAMETER SETTINGS - 581102-01**

Parameter	Field Setting	Description
NOTE - Any changes to Smoke CFM setting must be adjusted before the other CFM settings. Use SETTINGS > RTU OPTIONS > EDIT PARAMETERS = 12 for EBM, 6 for ECM		
BLOWER SMOKE CFM	%	Percentage of RPM for blower smoke speed.
SETUP > TEST & BALANCE > BLOWER		
BLOWER HEATING HIGH CFM	%	Percentage of RPM for blower heating high speed.
BLOWER HEATING LOW CFM	%	Percentage of RPM for blower heating low speed (P volt gas heat only).
BLOWER COOLING HIGH CFM	%	Percentage of RPM for blower cooling high speed.
BLOWER COOLING LOW CFM	%	Percentage of RPM for blower cooling low speed and vent speed for standard static blowers.
BLOWR VENTILATION CFM	%	Percentage of RPM for high static blower ventilation speed.
SETUP > TEST & BALANCE > DAMPER		
BLOWER HIGH CFM DAMPER POS %	%	Minimum damper position for high speed blower operation. Default 0%.
BLOWER LOW CFM DAMPER PS %	%	Minimum damper position for low speed blower operation. Default 0%.
POWER EXHAUST DAMPER POS %	%	Minimum damper position for low power exhaust operation. Default 50%.
SETTING > RTU OPTIONS > EDIT PARAMETERS = 216		
POWER EXHAUST DEADBAND %	%	Deadband % for power exhaust operation. Default 10%.
SETTINGS > RTU OPTIONS > EDIT PARAMETERS = 10 (Applies to Thermostat Mode ONLY)		
FREE COOLING STAGE-UP DELAY	sec	Number of seconds to hold blower at low speed before switching to blower at high speed. Default 300 seconds.

Installer - Record any parameter changes under "Field Setting" column. Settings need to be recorded by installer for use when Unit Controller is replaced or reprogrammed.

BLOWER DATA

BLOWER TABLE INCLUDES RESISTANCE FOR BASE UNIT ONLY (NO HEAT SECTION) WITH DRY INDOOR COIL AND AIR FILTERS IN PLACE.

FOR ALL UNITS ADD:

- 1- Wet indoor coil air resistance of selected unit.
- 2- Any factory installed options air resistance (heat section, Economizer, etc.)
- 3- Any field installed accessories air resistance (duct resistance, diffuser, etc.)

See page 18 for wet coil and option/accessory air resistance data.

See page 18 for minimum air volume required for use with optional electric heat.

Maximum Static Pressure With Gas Heat - 2.0 in. w.g.

Minimum Air Volume Required For Different Gas Heat Sizes:

Standard - 2150 cfm; Medium - 2250 cfm; High - 2600 cfm

Total Air Volume cfm	Total Static Pressure - in. w.g.													
	0.2		0.4		0.6		0.8		1.0		1.2		1.4	
	RPM	Watts	RPM	Watts	RPM	Watts	RPM	Watts	RPM	Watts	RPM	Watts	RPM	Watts
1750	759	223	864	298	961	359	1049	420	1128	508	1199	607	1260	704
2000	846	271	943	345	1035	410	1117	488	1189	598	1255	704	1313	804
2250	945	303	1030	391	1111	476	1184	577	1247	697	1310	806	1367	905
2500	1035	366	1109	476	1180	583	1245	688	1306	797	1368	903	1426	1008
2750	1113	476	1182	601	1248	715	1310	809	1371	902	1432	1011	1491	1129
3000	1195	596	1261	718	1324	827	1385	922	1444	1024	1503	1146	1559	1279
3250	1282	711	1346	827	1406	935	1464	1044	1521	1167	1576	1306	1629	1460
3500	1372	821	1432	940	1489	1060	1544	1192	1598	1337	1650	1494	1700	1663
3750	1461	949	1517	1081	1571	1221	1624	1373	1675	1532	1725	1700	1773	1875
4000	1549	1109	1602	1256	1653	1413	1703	1576	1753	1743	1801	1916	1847	2091
4250	1637	1298	1687	1458	1735	1625	1784	1795	1831	1966	1877	2139	1923	2310
4500	1724	1510	1772	1678	1818	1851	1864	2023	1910	2195	1955	2365	2000	2530
4750	1811	1738	1856	1910	1901	2083	1946	2254	1990	2423	2034	2587	2079	2746
5000	1897	1973	1941	2144	1985	2314	2028	2480	2071	2644	2114	2805	2158	2959
5250	1983	2205	2026	2373	2069	2538	2111	2699	2153	2860	2195	3017	---	---
5500	2070	2428	2112	2595	2153	2756	2194	2912	---	---	---	---	---	---
5750	2156	2643	2197	2809	---	---	---	---	---	---	---	---	---	---

Total Air Volume cfm	Total Static Pressure - in. w.g.											
	1.6		1.8		2.0		2.2		2.4		2.6	
	RPM	Watts	RPM	Watts	RPM	Watts	RPM	Watts	RPM	Watts	RPM	Watts
1750	1316	793	1373	875	1432	963	1491	1064	1548	1175	1604	1300
2000	1368	894	1425	982	1483	1081	1540	1196	1596	1322	1650	1458
2250	1423	1001	1480	1101	1537	1216	1593	1344	1647	1483	1700	1629
2500	1483	1117	1539	1236	1594	1368	1648	1509	1700	1657	1752	1810
2750	1547	1256	1601	1394	1654	1539	1705	1690	1756	1846	1806	2004
3000	1612	1425	1664	1577	1715	1734	1765	1893	1815	2053	1864	2213
3250	1680	1623	1729	1787	1778	1949	1828	2110	1876	2269	1925	2426
3500	1748	1835	1796	2003	1844	2165	1893	2324	1942	2479	1991	2633
3750	1819	2048	1866	2214	1914	2374	1963	2530	2012	2684	2061	2837
4000	1893	2260	1940	2423	1988	2581	2036	2737	2084	2891	2134	3044
4250	1969	2475	2016	2634	2063	2790	2111	2945	2159	3098	---	---
4500	2046	2689	2093	2844	2140	2998	2187	3153	---	---	---	---
4750	2124	2900	2170	3053	---	---	---	---	---	---	---	---
5000	2203	3111	---	---	---	---	---	---	---	---	---	---
5250	---	---	---	---	---	---	---	---	---	---	---	---
5500	---	---	---	---	---	---	---	---	---	---	---	---

BLOWER DATA

FACTORY INSTALLED OPTIONS/FIELD INSTALLED ACCESSORY AIR RESISTANCE - in. w.g.

Air Volume cfm	Wet Indoor Coil		Gas Heat Exchanger			Electric Heat (LHT)	Econo-mizer	Filters			Return Air Adaptor Plate
	092, 102	122, 150	Standard Heat	Medium Heat	High Heat			MERV 8	MERV 13	MERV 16	
1750	0.04	0.04	0.06	0.02	0.02	0.03	0.05	0.01	0.03	0.06	0.00
2000	0.05	0.05	0.07	0.05	0.06	0.03	0.06	0.01	0.03	0.08	0.00
2250	0.06	0.06	0.07	0.07	0.08	0.04	0.08	0.01	0.04	0.09	0.00
2500	0.07	0.07	0.09	0.10	0.11	0.04	0.11	0.01	0.05	0.10	0.00
2750	0.08	0.08	0.09	0.11	0.12	0.05	0.12	0.02	0.05	0.11	0.00
3000	0.10	0.09	0.11	0.12	0.13	0.06	0.13	0.02	0.06	0.12	0.02
3250	0.11	0.10	0.12	0.15	0.16	0.06	0.15	0.02	0.06	0.13	0.02
3500	0.12	0.11	0.12	0.16	0.17	0.09	0.15	0.03	0.07	0.15	0.04
3750	0.14	0.13	0.14	0.19	0.20	0.09	0.15	0.03	0.08	0.16	0.07
4000	0.15	0.14	0.14	0.21	0.22	0.09	0.19	0.04	0.08	0.17	0.09
4250	0.17	0.15	0.14	0.24	0.28	0.13	0.19	0.04	0.09	0.19	0.11
4500	0.19	0.17	0.15	0.26	0.32	0.14	0.22	0.04	0.09	0.20	0.12
4750	0.20	0.18	0.16	0.29	0.37	0.17	0.25	0.05	0.10	0.21	0.16
5000	0.22	0.20	0.16	0.34	0.43	0.20	0.29	0.06	0.10	0.23	0.18
5250	0.24	0.22	0.16	0.37	0.47	0.22	0.32	0.06	0.11	0.24	0.19
5500	0.25	0.23	0.18	0.44	0.54	0.25	0.34	0.07	0.12	0.25	0.22
5750	0.27	0.25	0.19	0.49	0.59	0.31	0.45	0.07	0.12	0.27	0.25
6000	0.29	0.27	0.20	0.54	0.64	0.33	0.52	0.08	0.13	0.28	0.27

MINIMUM AIR VOLUME REQUIRED FOR USE WITH OPTIONAL ELECTRIC HEAT

Electric Heat kW	Minimum cfm
7.5	1750
15	2250
22.5	2250
30	2750
45	2750
60	3500

Cooling Start-Up

IMPORTANT - The crankcase heater must be energized for 24 hours before attempting to start compressor. Set thermostat so there is no demand to prevent compressors from cycling. Apply power to unit.

A-Start-Up

- 1 - Initiate full load cooling operation using the following mobile service app menu path:

RTU MENU > SERVICE > COMPONENT TEST > COOLING > COOLING STAGE 3

- 2 - Refer to Cooling Operation section for cooling start-up.
- 3 - Units have two refrigerant circuits. See FIGURE 19 or FIGURE 20.
- 4 - Each refrigerant circuit is charged with R410A refrigerant. See unit rating plate for correct amount of charge.
- 5 - Refer to Refrigerant Check and Charge section for proper method to check refrigerant charge.

REFRIGERANT STAGES - TWO FANS LHT/LDT078, 092, 102H:

Two-Stage Thermostat/Control:

Y1 Demand = Outdoor Fan 1 HIGH Speed, Fan 2 OFF
Y2 Demand = Outdoor Fans 1 & 2 HIGH Speed
W1 Demand (Heat Pump Heating) =
Outdoor Fans 1 & 2 HIGH Speed

Three-Stage Thermostat/Control:

Y1 Demand = Outdoor Fan 1 LOW Speed, Fan 2 OFF
Y2 Demand = Outdoor Fans 1, 2 MEDIUM Speed
Y3 Demand = Outdoor fans 1, 2, HIGH Speed
W1 Demand (HP Heating)=
Outdoor Fans 1, 2 High Speed

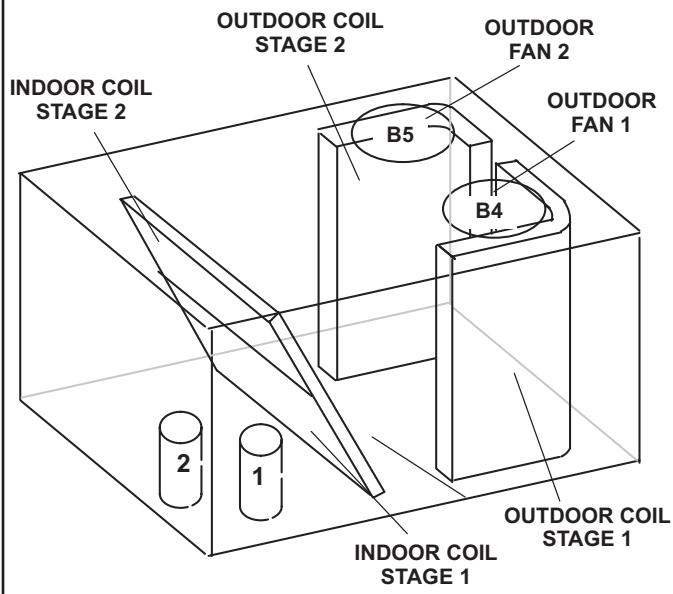

FIGURE 19

REFRIGERANT STAGES - THREE FANS LHT/LDT122, 150H:

Two-Stage Thermostat/Control:

Y1 Demand = Outdoor Fans 1, 2, & 3 MEDIUM Speed
Y2 Demand = Outdoor Fans 1, 2 & 3 HIGH Speed
W1 Demand (Heat Pump Heating) =
Outdoor Fans 1, 2, 3 HIGH Speed

Three-Stage Thermostat/Control:

Y1 Demand = Outdoor Fans 1, 2, & 3 LOW Speed
Y2 Demand = Outdoor Fans 1, 2, & 3 MEDIUM Speed
Y3 Demand = Outdoor Fans 1, 2, & 3 HIGH Speed
W1 Demand (HP Heating)=
Outdoor Fans 1, 2, & 3 HIGH Speed

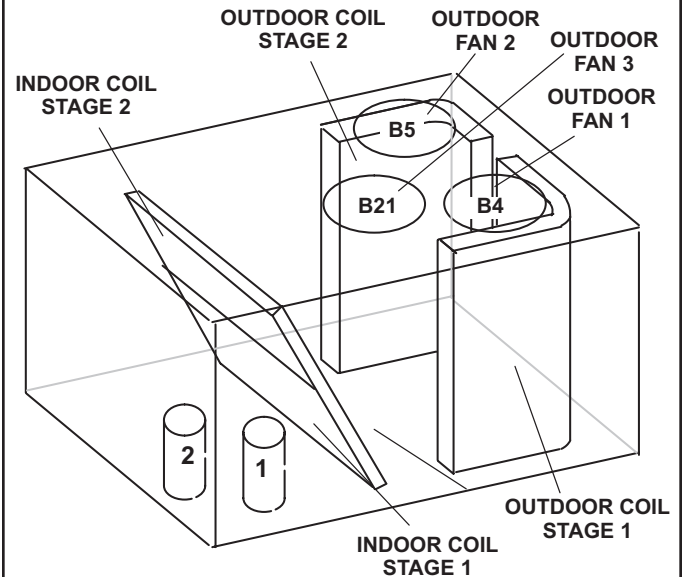

FIGURE 20

B-R410A Refrigerant

Units charged with R410A refrigerant operate at much higher pressures than R22. The expansion valve and liquid line drier provided with the unit are approved for use with R410A. Do not replace them with components designed for use with R22.

R410A refrigerant is stored in a pink cylinder.

Manifold gauge sets used with systems charged with R410A refrigerant must be capable of handling the higher system operating pressures. The gauges should be rated for use with pressures of 0-800 on the high side and a low side of 30" vacuum to 250 psi with dampened speed to 500 psi. Gauge hoses must be rated for use at up to 800 psi of pressure with a 4000 psi burst rating.

! IMPORTANT

Mineral oils are not compatible with R410A. If oil must be added, it must be a polyol ester oil.

C-Refrigerant Charge and Check - Fin/Tube

WARNING - Do not exceed nameplate charge under any condition.

This unit is factory charged and should require no further adjustment. If the system requires additional refrigerant, reclaim the charge, evacuate the system, and add required nameplate charge.

NOTE - System charging is not recommended below 60°F (15°C). In temperatures below 60°F (15°C), the charge must be weighed into the system.

If weighing facilities are not available, or to check the charge, use the following procedure:

- 1 - Attach gauge manifolds to discharge and suction lines. With the economizer disabled, operate the unit **in cooling mode at high speed** using the following mobile service app menu path:

SERVICE > COMPONENT TEST > COOLING > COOLING STAGE 3

- 2 - Check each system separately with all stages operating.
- 3 - Use a thermometer to accurately measure the outdoor ambient temperature.
- 4 - Apply the outdoor temperature to TABLE 4 through TABLE 8 to determine normal operating pressures. Pressures are listed for sea level applications at 80°F dry bulb and 67°F wet bulb return air.
- 5 - Compare the normal operating pressures to the pressures obtained from the gauges. Minor variations in these pressures may be expected due to differences in installations. Significant differences could mean that the system is not properly charged or that a problem exists with some component in the system. **Correct any system problems before proceeding.**
- 6 - If discharge pressure is high, remove refrigerant from the system. If discharge pressure is low, add refrigerant to the system.
 - Add or remove charge in increments.
 - Allow the system to stabilize each time refrigerant is added or removed.
- 7 - Use the following approach method along with the normal operating pressures to confirm readings.

**TABLE 4 581118-01
LHT/LDT078**

OD Coil Entering Air Temp	Circuit 1			Circuit 2		
	Disch. ± 10 psig	Suct. ± 5 psig	Appr. Temp ±1°F	Disch. ± 10 psig	Suct. ± 5 psig	Appr. Temp ±1°F
65°F	244	132	5	236	145	4
75°F	281	134	3	271	146	3
85°F	322	136	3	309	148	2
95°F	366	138	3	354	150	2
100°F	415	139	4	399	152	2
115°F	464	141	4	449	154	3

**TABLE 5 581119-01
LHT/LDT092**

OD Coil Entering Temp.	CIRCUIT 1			CIRCUIT 2		
	Disch. ± 10 psig	Suct. ± 5 psig	Appr. Temp±1°F	Disch. ± 10 psig	Suct. ± 5 psig	Appr. Temp±1°F
65 °F	250	139	4	253	139	8
75 °F	286	140	4	291	140	7
85 °F	326	141	4	331	141	6
95 °F	370	142	3	376	143	5
105 °F	417	144	4	426	146	7
115 °F	468	146	5	481	148	7

**TABLE 6 581120-01
LHT/LDT102**

OD Coil Entering Temp.	CIRCUIT 1			CIRCUIT 2		
	Disch. ± 10 psig	Suct. ± 5 psig	Appr. Temp±1°F	Disch. ± 10 psig	Suct. ± 5 psig	Appr. Temp±1°F
65 °F	245	139	3	258	130	3
75 °F	283	142	3	296	133	4
85 °F	321	141	3	336	133	4
95 °F	370	146	4	389	138	6
105 °F	417	148	5	435	141	7
115 °F	469	151	6	492	144	8

**TABLE 7 581121-01
LHT/LDT122**

OD Coil Entering Temp.	CIRCUIT 1			CIRCUIT 2		
	Disch. ± 10 psig	Suct. ± 5 psig	Appr. Temp±1°F	Disch. ± 10 psig	Suct. ± 5 psig	Appr. Temp±1°F
65 °F	248	126	1	256	125	2
75 °F	285	128	0	293	127	0
85 °F	326	130	0	334	129	0
95 °F	372	132	0	379	131	0
105 °F	420	135	1	426	134	0
115 °F	475	139	1	477	137	0

**TABLE 8 581122-01
LHT/LDT150**

OD Coil Entering Temp.	CIRCUIT 1			CIRCUIT 2		
	Disch. ± 10 psig	Suct. ± 5 psig	Appr. Temp±1°F	Disch. ± 10 psig	Suct. ± 5 psig	Appr. Temp±1°F
65 °F	255	125	3	252	112	3
75 °F	295	128	0	293	124	0
85 °F	337	130	0	335	130	0
95 °F	382	134	1	381	133	0
105 °F	430	136	1	427	135	1
115 °F	485	139	2	476	137	1

Charge Verification - Approach Method - AHRI Testing

- 1 - Using the same thermometer, compare liquid temperature to outdoor ambient temperature. Approach Temperature = Liquid temperature (at condenser outlet) minus ambient temperature.
- 2 - Refer to TABLES 4-8 for approach temperatures. An approach temperature greater than value shown indicates an undercharge. An approach temperature less than value shown indicates an overcharge.
- 3 - The approach method is not valid for grossly over or undercharged systems. Use TABLE 4-8 as a guide for typical operating pressures.

F-Compressor Controls

See unit wiring diagram to determine which controls are used on each unit.

- 1 - High Pressure Switch (S4, S7)

The compressor circuit is protected by a high pressure switch which opens at 640 psig + 10 psig (4413 kPa + 70 kPa) and automatically resets at 475 psig + 20 psig (3275kPa + 138 kPa).

- 2 - Low Pressure Switch (S87, S88)

The compressor circuit is protected by a loss of charge switch. Switch opens at 25 psig + 5 psig (172 + 34 kPa) and automatically resets at 40 psig + 5 psig (276 kPa + 34 kPa).

- 3 - Crankcase Heater (HR1, HR2)

Compressors have belly band compressor oil heaters which must be on 24 hours before running compressors. Energize by setting thermostat so that there is no cooling demand, to prevent compressor from cycling, and apply power to unit.

- 4 - Diagnostics Sensors (RT46-RT49)

Four thermistors are located on specific points in the refrigeration circuit. The thermistors provide constant temperature feedback to the Unit Controller to protect the compressor. Thermistors take the place of the freeze-stat and low ambient pressure switch.

Cooling Start-Up

Units are equipped with four factory-installed thermistors (RT46 - RT49) located on different points on the refrigerant circuit.

The thermistors provide the Unit Controller with constant temperature readings of four specific locations on the refrigeration circuit. These temperatures are used as feedback in certain modes of unit operation. In addition, the Unit Controller uses these temperatures to initiate alarms such as loss of outdoor or indoor coil airflow.

Each thermistor must be specifically placed for proper unit operation and to initiate valid alarms. See FIGURE 21 and FIGURE 22 for proper locations.

LHT/LDT078, 092, 102, 122, 150
INDOOR COIL
RT46, RT47

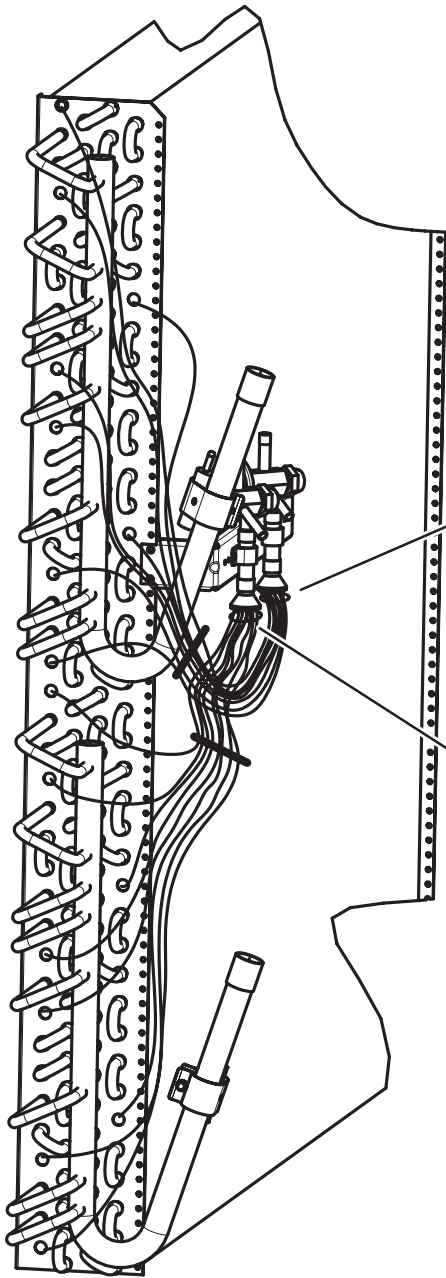

22J06
BLUE
RT47

22J06
YELLOW
RT46

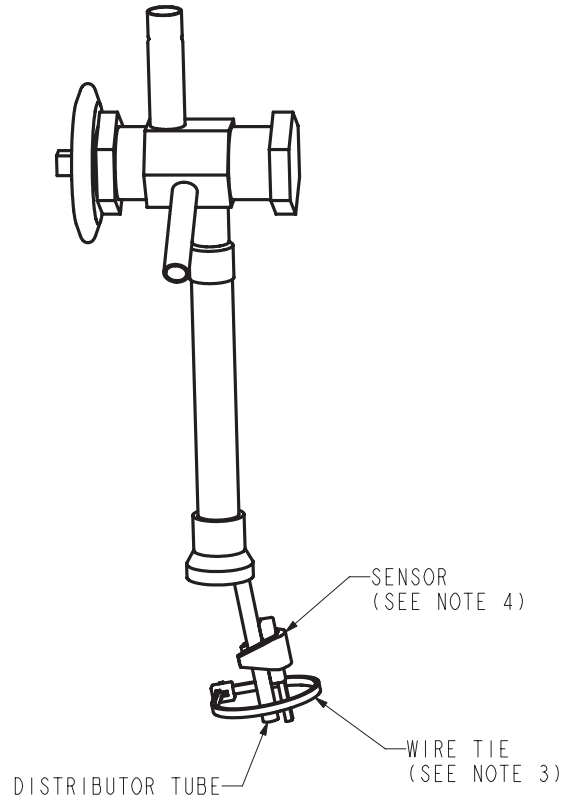

DETAILS NOT TO SCALE

FIGURE 21

LHT/LDT078, 092, 102, 122, 150
OUTDOOR COIL
RT48, RT49

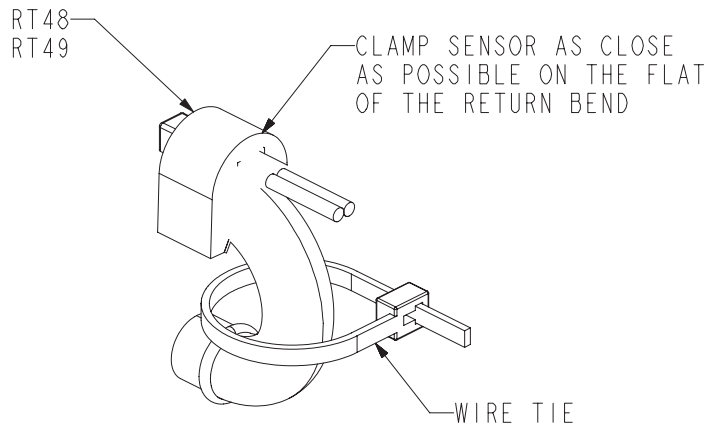

SENSOR DETAIL

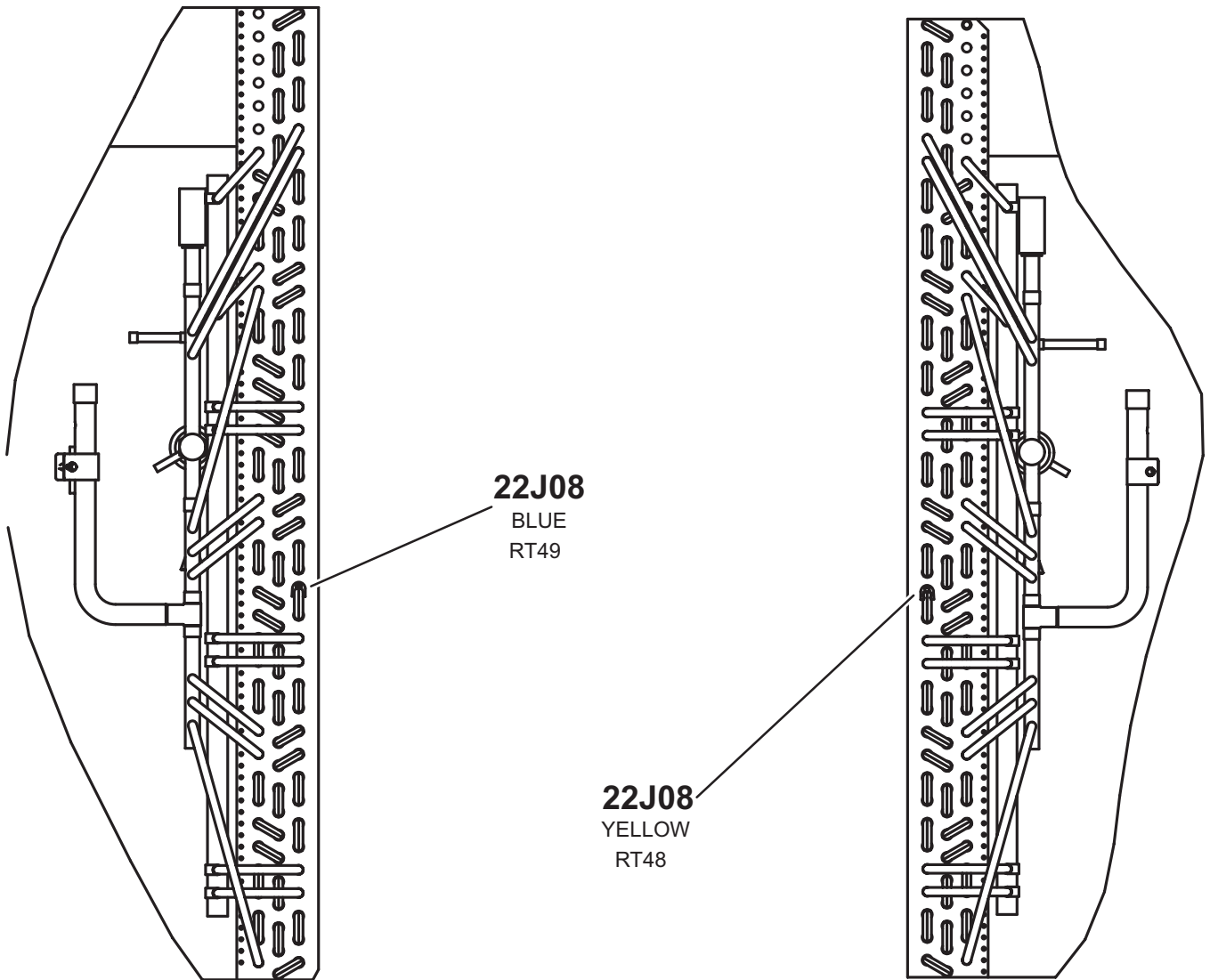

STAGE 2

DETAILS NOT TO SCALE

FIGURE 22

Heating Start-Up (LDT)

FOR YOUR SAFETY, READ BEFORE LIGHTING.

⚠ WARNING



Electric shock hazard. Can cause injury or death. Do not use this unit if any part has been under water. Immediately call a qualified service technician to inspect the unit and to replace any part of the control system and any gas control which has been under water.

⚠ WARNING



Danger of explosion. Can cause injury or product or property damage. If overheating occurs or if gas supply fails to shut off, shut off the manual gas valve to the appliance before shutting off electrical supply.

⚠ WARNING



Electric shock hazard. Can cause injury or death. Before attempting to perform any service or maintenance, turn the electrical power to unit OFF at disconnect switch(es). Unit may have multiple power supplies.

⚠ WARNING

SMOKE POTENTIAL

The heat exchanger in this unit could be a source of smoke on initial firing. Take precautions with respect to building occupants and property. Vent initial supply air outside when possible.

BEFORE LIGHTING smell all around the appliance area for gas. Be sure to smell next to the floor because some gas is heavier than air and will settle on the floor.

Use only your hand to push in or turn the gas control knob. Never use tools. If the knob will not push in or turn by hand, do not try to repair it, call a qualified service technician. Force or attempted repair may result in a fire or explosion.

⚠ WARNING



Danger of explosion. Can cause injury or death. Do not attempt to light manually. Unit has a direct spark ignition system.

This unit is equipped with an automatic spark ignition system. There is no pilot. In case of a safety shutdown, move thermostat switch to **OFF** and return the thermostat switch to **HEAT** to reset ignition control.

A-Placing Unit In Operation

⚠ WARNING



Danger of explosion and fire. Can cause injury or product or property damage. You must follow these instructions exactly.

Gas Valve Operation for Honeywell VR8205Q/VR8305Q and White Rodgers 36H54 (FIGURE 23 and FIGURE 24).

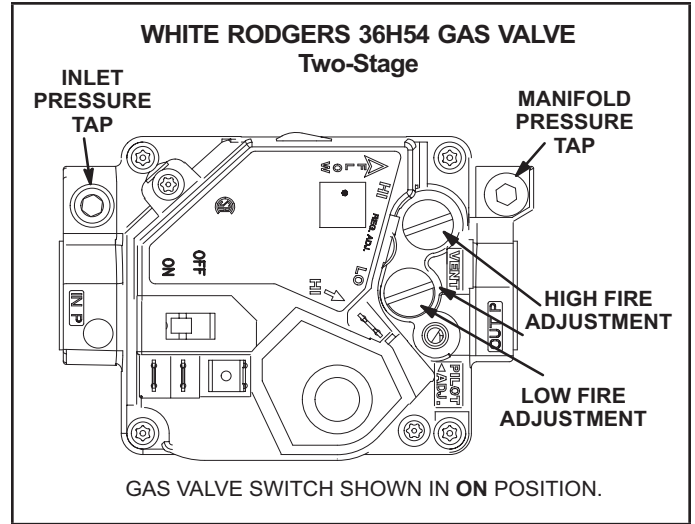

FIGURE 23

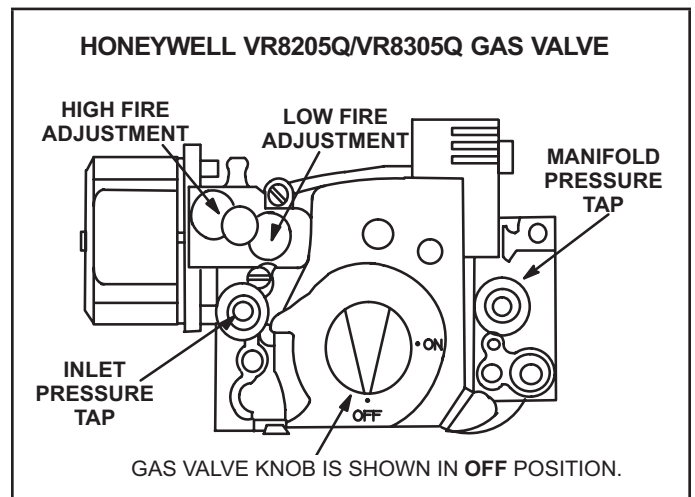

FIGURE 24

- 1 - Set balance point setpoint above the outdoor ambient temperature to disable heat pump operation.
- 2 - Set thermostat to lowest setting.
- 3 - Turn off all electrical power to appliance.

- 4 - This appliance is equipped with an ignition device which automatically lights the burner. Do not try to light the burner by hand.
- 5 - Open or remove the heat section access panel.
- 6 - Turn gas valve switch to **OFF**. See FIGURE 23. On Honeywell VR8305Q gas valves, turn the knob on the gas valve clockwise to **OFF**. Do not force. See FIGURE 24.
- 7 - Wait five (5) minutes to clear out any gas. If you then smell gas, **STOP!** Immediately call your gas supplier from a neighbor's phone. Follow the gas supplier's instructions. If you do not smell gas, go to the next step.
- 8 - Turn gas valve switch to **ON**. See FIGURE 23. On Honeywell VR8305Q gas valves, turn the knob on the gas valve counterclockwise to **ON**. Do not force. See FIGURE 24.
- 9 - Close or replace the heat section access panel.
- 10 - Turn on all electrical power to appliance.
- 11 - Set thermostat to desired setting.
- 12 - The ignition sequence will start.

- 13 - If the appliance does not light the first time (gas line not fully purged), it will attempt up to two more ignitions before locking out.
- 14 - If lockout occurs, repeat steps 1 through 10.
- 15 - If the appliance will not operate, follow the instructions "Turning Off Gas to Appliance" and call your service technician or gas supplier.

Turning Off Gas to Unit

- 1 - If using an electromechanical thermostat, set to the lowest setting.
- 2 - Before performing any service, turn off all electrical power to the appliance.
- 3 - Open or remove the heat section access panel.
- 4 - Turn gas valve switch to **OFF**. On Honeywell VR8305 gas valves, turn the knob on the gas valve clockwise to **OFF**. Do not force.
- 5 - Close or replace the heat section access panel.

 WARNING	
	Danger of explosion. Can cause injury or death. Do not attempt to light manually. Unit has a direct spark ignition system.

Heating Operation and Adjustments

(Gas Units)

A-Heating Sequence of Operation

- 1 - On a heating demand the combustion air inducer starts immediately.
- 2 - Combustion air pressure switch proves inducer operation. After a 30-second pre-purge, power is allowed to ignition control. Switch is factory set and requires no adjustment.
- 3 - Spark ignitor energizes and gas valve solenoid opens.
- 4 - Spark ignites gas, ignition sensor proves the flame and combustion continues.
- 5 - If flame is not detected after first ignition trial, ignition control will repeat steps 3 and 4 two more times before locking out the gas valve.
- 6 - For troubleshooting purposes, an ignition attempt after lock out may be re-established manually. Move thermostat to **OFF** and return thermostat switch to **HEAT** position.

B-LDT Heating Stages

TABLE 9

Outdoor Ambient Temperature	W1 Demand	W2 Demand
Above Balance Point Temperature Setting**	Compr. 1 & 2 On* Gas Heat Off	Compr. 1 & 2 Off Gas Heat High
Below Balance Point Temperature Setting**	Compr. 1 & 2 Off Gas Heat Low	Compr. 1 & 2 Off Gas Heat High

*L1 and L2 reversing valves are de-energized with a heating demand. The heat pump will heat only, not cool.

**Balance Point temperature setting can be adjusted using the following mobile service app menu path:

RTU MENU > SETTING > RTU OPTIONS > EDIT PARAMETER = 526 (HP DF BALANCE POINT)

C-Limit Controls

Limit controls are factory-set and are not adjustable. The primary limit is located on the blower deck to the right of the blower housing.

D-Heating Adjustment

Main burners are factory-set and do not require adjustment. The following manifold pressures are listed on the gas valve.

Natural Gas Units - Low Fire - 1.6" w.c. (not adjustable)

Natural Gas Units - High Fire - 3.7" w.c.

LP Gas Units - Low Fire - 5.5" w.c. (not adjustable)

LP Gas Units - High Fire - 10.5" w.c.

Electric Heat Start-Up (LHT Units)

Factory- or Field-Installed Option

A W1 demand will energize compressors 1 and 2. An increased W2 heating demand will energize electric heat. W1 will also energize electric heat during defrost to maintain discharge air temperature.

NOTE - L1 and L2 reversing valves are de-energized with a heating demand. The heat pump will heat only, not cool.

Cooling Operation

This is a summary of cooling operation. Refer to the sequence of operation provided in the Engineering Handbook or Service Manual for more detail.

A-Two-Stage Thermostat

1 - Economizer With Outdoor Air Suitable

Y1 Demand -

- Compressors Off
- Blower Cooling Low
- Dampers Modulate

Y2 Demand -

- Compressors Off
- Blower Cooling High
- Dampers Modulate

NOTE - If dampers are at maximum open for five minutes, compressors are energized and blower stays on cooling high.

Y2 Demand -

- Compressor Full Load
- Blower Cooling High Dampers
- Maximum Open

2 - No Economizer or Outdoor Air Not Suitable

Y1 Demand -

- Compressor 1 Full Load
- Blower Cooling Low
- Dampers Minimum Position

Y2 Demand -

- Compressors Both Full Load
- Blower Cooling High
- Dampers Minimum Position

B-Room Sensor

1 - Economizer With Outdoor Air Suitable

- Compressors Off
- Blower Modulates
- Dampers Modulate

NOTE - If dampers are at maximum open for five minutes, compressors are energized and the blower modulates.

2 - No Economizer or Outdoor Air Not Suitable

- Compressors 1 Full Load
- Blower High
- Dampers Minimum Position

C-Three-Stage Thermostat

1 - Economizer With Outdoor Air Suitable

Y1 Demand -

- Compressors Off
- Blower Cooling Medium
- Dampers Modulate

Y2 Demand -

- Compressors Off
- Blower Cooling High
- Dampers Modulate

NOTE - If dampers are at maximum open for five minutes, compressors are energized and blower stays on cooling high.

Y2 Demand -

- Compressor 1 Part Load
- Blower Cooling High Dampers
- Maximum Open

Y3 Demand -

- Compressor 1 Full Load
- Blower Cooling High
- Dampers Maximum Open

2 - No Economizer or Outdoor Air Not Suitable

Y1 Demand -

- Compressor 1 Part Load
- Blower Cooling Low
- Dampers Minimum Position

Y2 Demand -

- Compressor 1 Part Load, Compressor 2 On
- Blower Cooling Medium
- Dampers Minimum Position

Y3 Demand -

- Compressors Both Full Load
- Blower Cooling High
- Dampers Maximum Open

D-Defrost

Defrost is enabled when outdoor coil temperature is below 35°F. The Unit Controller will cycle in and out of defrost depending on the temperature difference between the outdoor coil and outdoor air temperature.

Defrost is also initiated when the accumulated run time with the outdoor coil temperature below 35°F reaches six hours.

NOTE - Only one refrigerant circuit will go into defrost at a time

Service

The unit should be inspected once a year by a qualified service technician.

⚠ CAUTION

Label all wires prior to disconnection when servicing controls. Wiring errors can cause improper and dangerous operation. Verify proper operation after servicing.

A-Filters

Units are equipped with four 20 X 25 X 2" filters. Filters should be checked monthly and replaced when necessary with filters of like kind and size. Take note of air flow direction marking on filter frame when reinstalling filters. See FIGURE 25.

NOTE - Filters must be U.L.C. certified or equivalent for use in Canada.

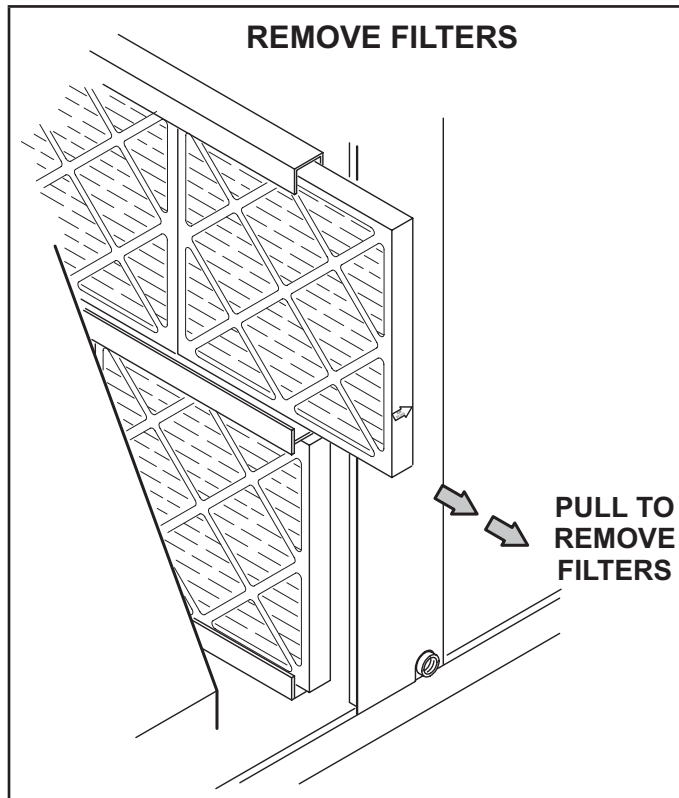

FIGURE 25

B-Lubrication

All motors are lubricated at the factory. No further lubrication is required.

C-Burners (Gas Units)

Periodically examine burner flames for proper appearance during the heating season. Before each heating season examine the burners for any deposits or blockage which may have occurred.

Clean burners as follows:

- 1 - Turn off both electrical power and gas supply to unit.
- 2 - Remove burner compartment access panel.
- 3 - Remove screws securing burner assembly to burner support and remove assembly. See FIGURE 26. Clean as necessary.

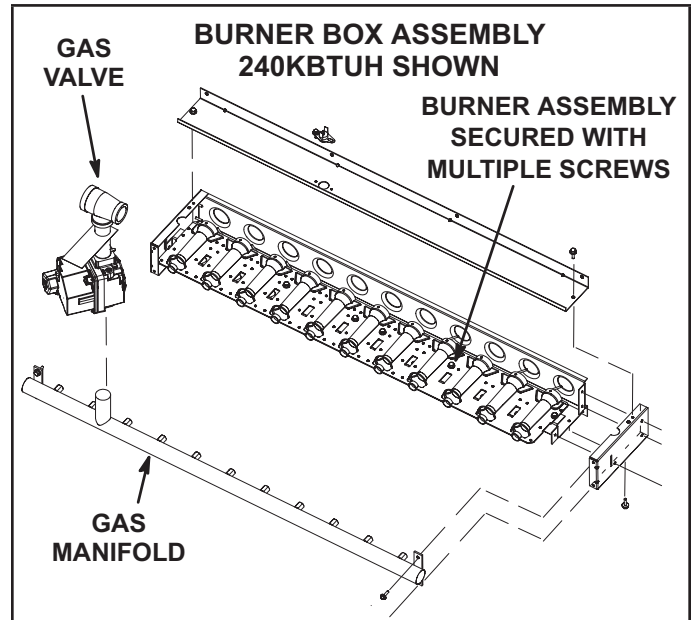

FIGURE 26

- 4 - Locate the ignitor under the left burners. Check ignitor spark gap with appropriately sized twist drills or feeler gauges. See FIGURE 27.

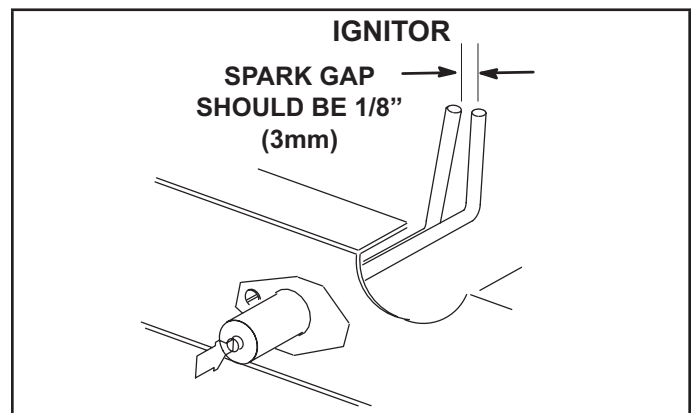

FIGURE 27

5 - Check the alignment of the ignitor and the sensor as shown in FIGURE 28 and TABLE 10.

TABLE 10

Dimension	Unit Btuh Input	Length - in. (mm)	
		Ignitor	Sensor
A	130K	7-3/4 (197)	11 (279)
B	180K	5 (127)	5-1/2 (140)
C	240K	2-1/4 (57)	2-3/4 (70)

- 6 - Replace burners and screws securing burner.
- 7 - Replace access panel.
- 8 - Restore electrical power and gas supply. Follow lighting instructions attached to unit and use inspection port in access panel to check flame.

WARNING

Danger of explosion. Can cause injury or death. Do not overtighten main burner mounting screws. Snug tighten only.

D-Combustion Air Inducer (Gas Units)

A combustion air proving switch checks combustion air inducer operation before allowing power to the gas controller. Gas controller will not operate if inducer is obstructed.

Under normal operating conditions, the combustion air inducer wheel should be checked and cleaned prior to the heating season. However, it should be examined periodically during the heating season to establish an ideal cleaning schedule. With power supply disconnected, the condition of the inducer wheel can be determined by looking through the vent opening.

Clean combustion air inducer as follows:

- 1 - Shut off power supply and gas to unit.
- 2 - Disconnect pressure switch air tubing from combustion air inducer port.
- 3 - Remove and retain screws securing combustion air inducer to flue box. Remove vent connector. See FIGURE 29.
- 4 - Clean inducer wheel blades with a small brush and wipe off any dust from housing. Clean accumulated dust from front of flue box cover.
- 5 - Return combustion air inducer motor and vent connector to original location and secure with retained screws. It is recommended that the combustion air inducer gasket be replaced during reassembly.
- 6 - Clean combustion air inlet louvers on heat access panel using a small brush.

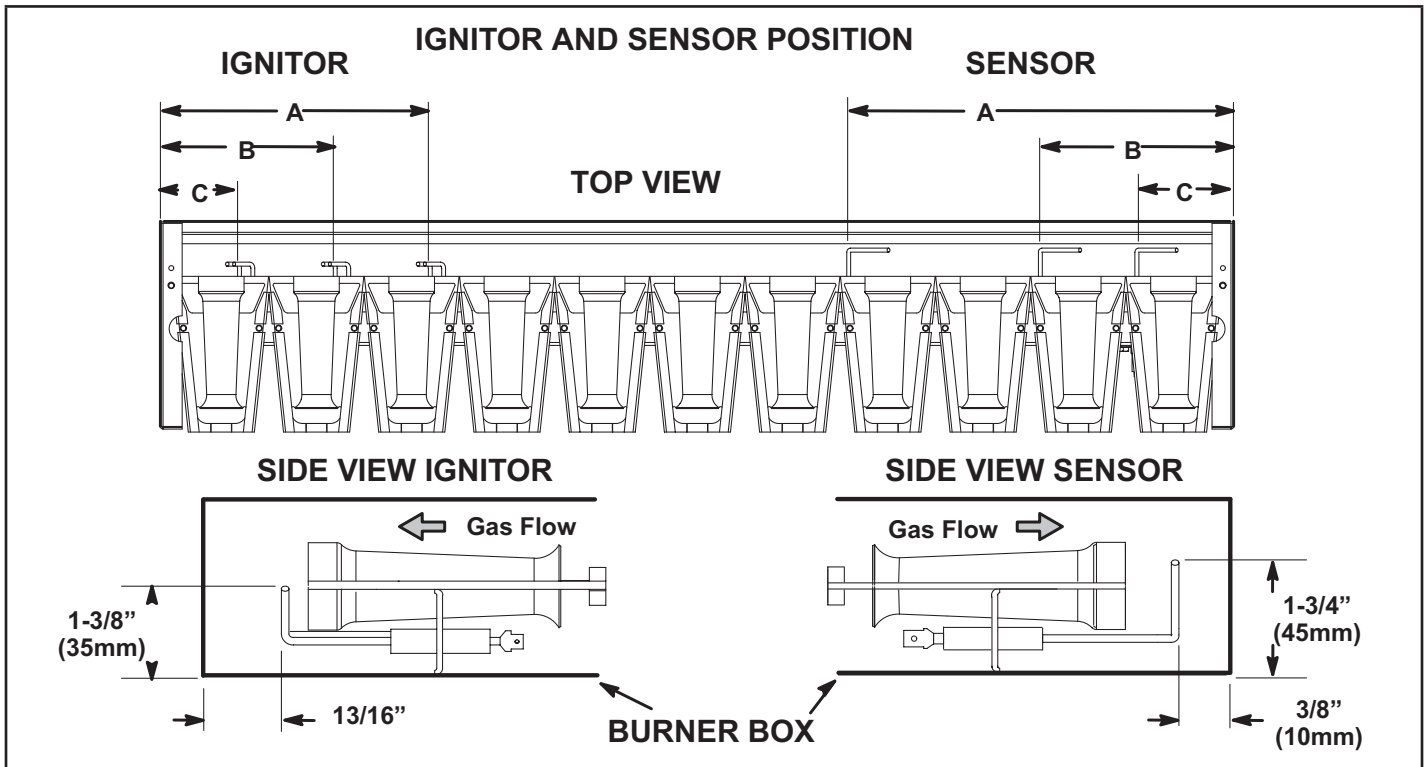

FIGURE 28

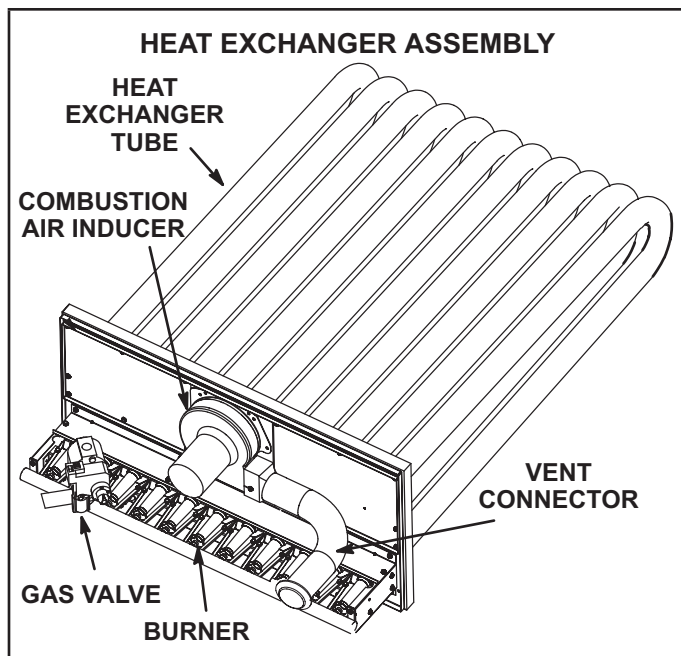

FIGURE 29

E-Flue Passageway and Flue Box (Gas Units)

- 1 - Remove combustion air inducer assembly as described in section D.
- 2 - Remove flue box cover. Clean with a wire brush as required.
- 3 - Clean tubes with a wire brush.
- 4 - Reassemble the unit. The flue box cover gasket and combustion air inducer gasket should also be replaced during reassembly.

F-Indoor Coil

Inspect and clean coil at beginning of each cooling season. Clean using mild detergent or commercial coil cleaner. Flush coil and condensate drain with water taking care not to get insulation, filters and return air ducts wet.

G-Supply Air Blower Wheel

Annually inspect supply air blower wheel for accumulated dirt or dust. Turn off power before attempting to remove access panel or to clean blower wheel.

H-Outdoor Coil

Clean outdoor coil annually with detergent or commercial coil cleaner and inspect monthly during the cooling season. Access panels are provided on front and back of outdoor section.

J-Needlepoint Bipolar Ionizer

The ionizer was designed for low maintenance. The device should be checked semi-annually to confirm the brushes are clean for maximum output. The ionizer is located on the blower deck. See FIGURE 30.

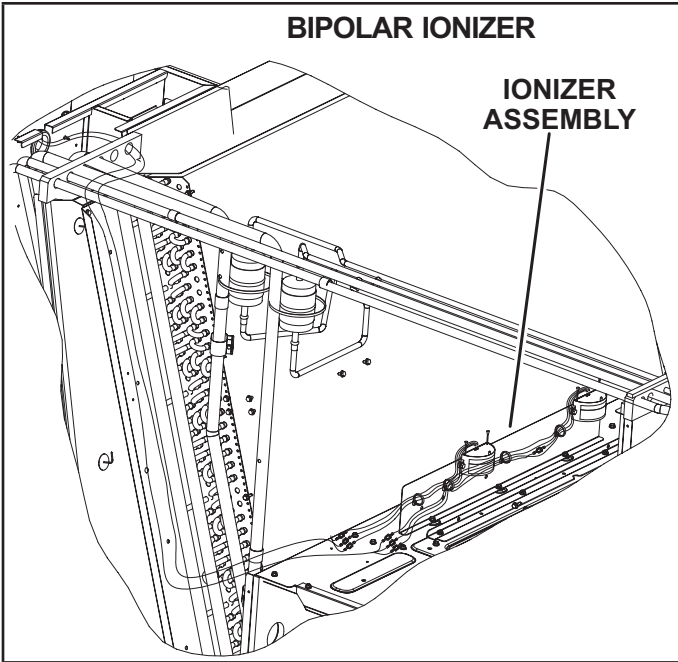

FIGURE 30

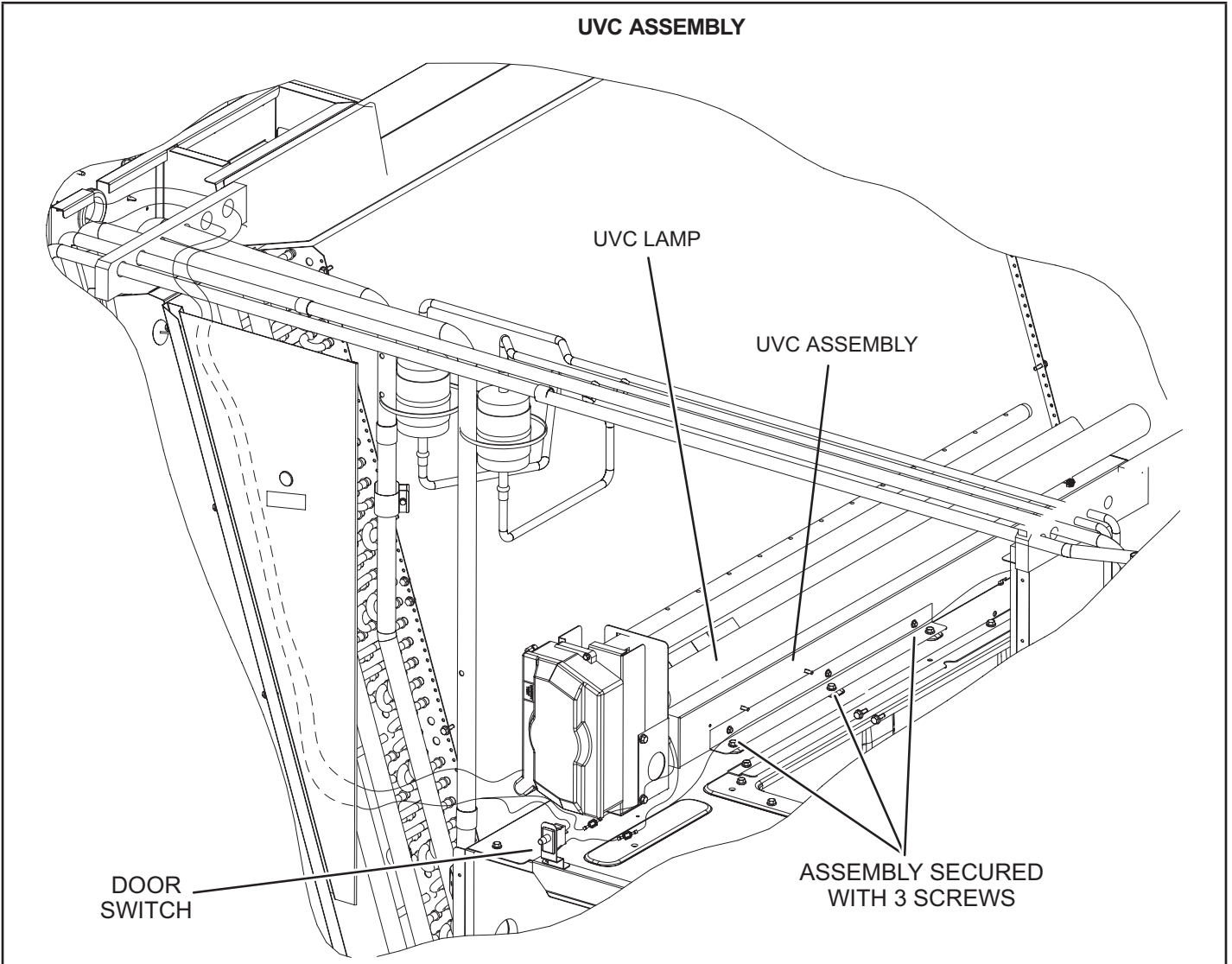

FIGURE 31

K-UVC Light

When field-installed, use only UVC Light Kit assembly 106882-01 (21A93) with this appliance.

Factory-Installed UVC Light

When the UVC light is factory installed, the lamp is shipped in a foam sleeve. The lamp is attached to the UVC light assembly on the blower deck. See FIGURE 31. Remove the lamp and install into the UVC light assembly as shown in steps 2 through 11.

Annual Lamp Replacement

⚠ WARNING

Personal Burn Hazard.

Personal injury may result from hot lamps. During replacement, allow lamp to cool for 10 minutes before removing lamp from fixture.

The lamp should be replaced every 12 months, as UVC energy production diminishes over time.

- 1 - Obtain replacement lamp 101087-01 for your germicidal light model.
- 2 - Disconnect power to the rooftop unit before servicing the UVC kit.
- 3 - Open the blower access door.
- 4 - Remove the screw in wire tie from the UVC assembly and disconnect the 4-pin connector from the lamp end.
- 5 - Remove and retain the (3) screws securing the UVC assembly. Carefully slide the complete UVC assembly out through the blower access door. See FIGURE 31.
- 6 - Allow 10 minutes before touching the lamps. Then, carefully remove the old lamp from the lamp holder clips.
- 7 - Wear cotton gloves or use a cotton cloth when handling the new lamp. Place the new lamp in the holder clips of the UVC assembly. Verify that the lamp flange at the connector end is sandwiched between the lamp holder clip and the sheet-metal end stop (see FIGURE 32).
- 8 - Carefully place the UVC assembly on the blower deck. Line up the mounting holes on the UVC assembly with the mounting holes on the blower deck. See FIGURE 31. Use the retained screws provided to attach the UVC assembly in place.
- 9 - Close the blower access door.
- 10 - Reconnect power to the rooftop unit.
- 11 - Open the filter access door and look through the view port in the triangular sheet-metal panel to verify that the UVC light is on.

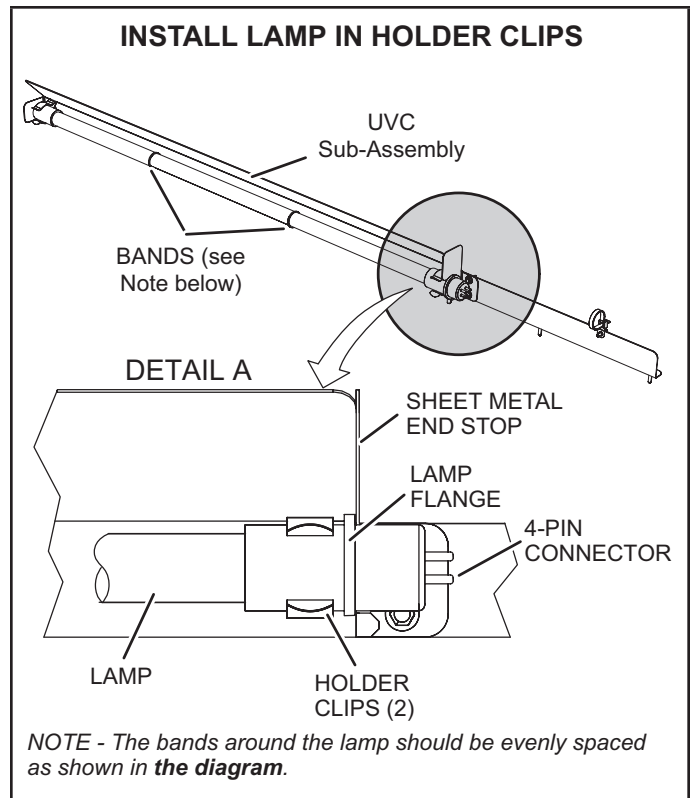

FIGURE 32

If UVC lamp does not come on:

- 1 - Check Power Wiring: Disconnect 1/4" QC (quick connects) of the UVC cable near the UVC assembly. With Power ON, use multimeter to test 110-230V at the 1/4"QC quick connects from the control panel.
- 2 - Check Lamp: Carefully remove the UVC assembly out of the rooftop unit. Use multimeter to test for continuity across each pair of pins at each end of the lamp.
- 3 - Check Lamp Installation: Make sure that lamp's pins snap properly into the lamp holder.

LED(s) not illuminated

Power status LED not lit—Check that the lamp unit is connected to the proper power source and is wired correctly.

Lamp status LED(s) not lit—

- 1 - Check that lamp 4-pin connectors are properly engaged.
- 2 - Ohm-check across the lamp pins to check for continuity of lamp filaments (see FIGURE 34).

Troubleshooting charts are provided to aid in determining the cause of any problems encountered (FIGURE 33 and FIGURE 34).

Lamp Disposal

Hg-LAMP Contains Mercury - Manage in accordance with local, state and federal disposal laws. Refer to www.lamprecycle.org or call 800-953-6669.

Proper Clean-up Technique in Case of Lamp Breakage

Wear protective gloves, eye wear and mask.

Sweep the broken glass and debris into a plastic bag, seal the bag, and dispose of properly. Contact your local waste management office for proper disposal.

Do not use a vacuum cleaner. Do not incinerate.

Maintenance

- For all maintenance, contact a qualified HVAC technician.
- Read the maintenance instructions before opening unit panels.

- Unintended use of the unit or damage to the unit housing may result in the escape of dangerous UVC radiation. UVC radiation may, even in small doses, cause harm to the eyes and skin.
- Do not operate units that are obviously damaged.
- Do not discard the triangular UVC light shield or any barriers with an ultraviolet radiation symbol.
- Do not override the door interlock switch that interrupts power to the UVC light.
- Do not operate the UVC light outside of the unit.

⚠ DANGER

Ultraviolet (UVC) Radiation hazard.

Any exposure will cause significant eye damage and may cause skin damage.

DO NOT look into UVC light source.

Access panels must be in place during appliance operation.

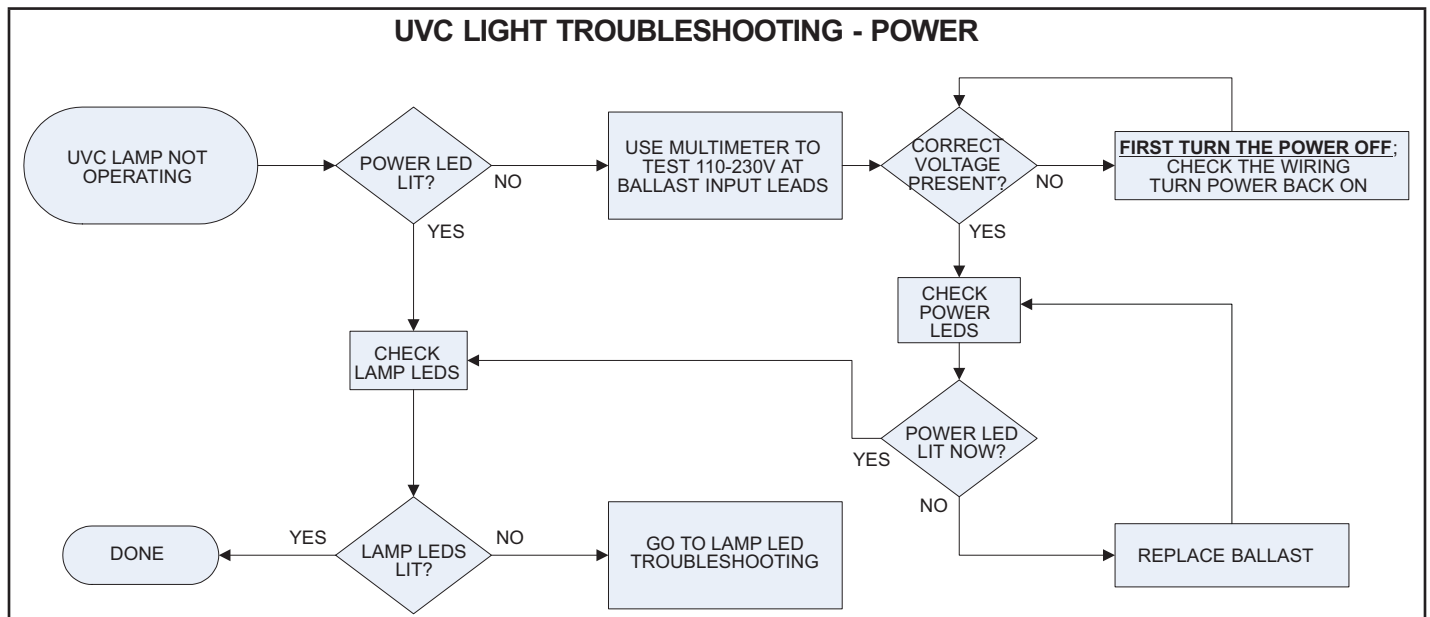

FIGURE 33

Field-Installed Accessories

When field-installing the following accessories, refer to the latest online installation instruction.

TABLE 11

Accessory	Instruction #
Economizer	507227-XX
Outdoor Air Damper	506340-XX
Electric Heat	507250-XX
Smoke Detector	506437-XX

Factory Unit Controller Settings

Use the mobile service app to adjust parameters; menu paths are shown in each table. Refer to the Unit Controller manual provided with each unit.

TABLE 12 and TABLE 13 show control options. When applicable, record field-specific information on the label located inside the compressor access panel.

When field installing optional kits and accessories, the Unit Controller must be configured to identify the option before it will function. Refer to FIGURE 35 and FIGURE 36 to determine whether the Unit Controller configuration I.D. must change. To configure the option, use RTU MENU > SETUP > INSTALL menu path. Press NEXT until CONFIGURATION ID 1 or 2 appears depending on the option installed. Change the appropriate character in the configuration I.D. For example, when an economizer is installed using a single enthalpy sensor, change configuration I.D. 1, the second character, to “S”.

**TABLE 12
581037-01**

Units With LonTalk Settings
Use menu RTU Menu > Network Integration > Network Setup Wizard > Set “LONTALK”

**TABLE 13
581038-01**

Units With BACnet Settings
RTU Menu > Network Integration > Network Setup Wizard > BACnet MS/TP > See BACnet MAC Address
BACNET MAC ADDRESS:
Units With Room Sensor, CPC/LSE Gateway Settings
RTU Menu > Network Integration > Network Setup Wizard > SBUS > Set SBUS Address
LCONN ADDRESS:

Configuration ID 1

1 2 3 4 5 6 7 8

Humiditrol [1]

Not Installed = **N**
 Humiditrol Installed = **H**
 Unconfigured = **U**

Economizer [2]

Not Installed = **N**
 Motorized Outdoor Air
 Damper Only = **M**
 Economizer - Temperature = **T**
 Economizer Global = **G**
 Economizer - Single
 Enthalpy = **S**
 Economizer - Dual Enthalpy = **D**
 Unconfigured = **U**

Power Exhaust [3]

Not Installed = **N**
 Single-Stage = **S**
 Dual-Stage = **D**
 Unconfigured = **U**

Power Exhaust Control 4]

Not Installed = **N**
 Damper Position = **A**
 A34 Pressure Sensor = **C**

[8] Outdoor Air Velocity Control

N = Not applicable (for future use)
L = Outdoor Air Control Installed with A24 Sensor set for low range.
M = Outdoor Air Control Installed with A24 Sensor set for medium range.
H = Outdoor Air Control Installed with A24 Sensor set for high range.

[7] System Blower Sub-type

N = Not Applicable.
B = VFD Belt Drive Blower (MODBUS).
H = Direct Drive Blower (MODBUS).
L = ECM Direct Drive Blower (PWM).
U = Unconfigured.
D = Direct Drive Blower.

[6] Blower Variable Frequency Drive Bypass

N = Not Installed
A = Automatic Bypass
M = Manual Bypass
U = Electronic Bypass Field Unconfigured

[5] Network Module

N = Not Installed
L = LonTalk (Lennox)

FIGURE 35

Configuration ID 2

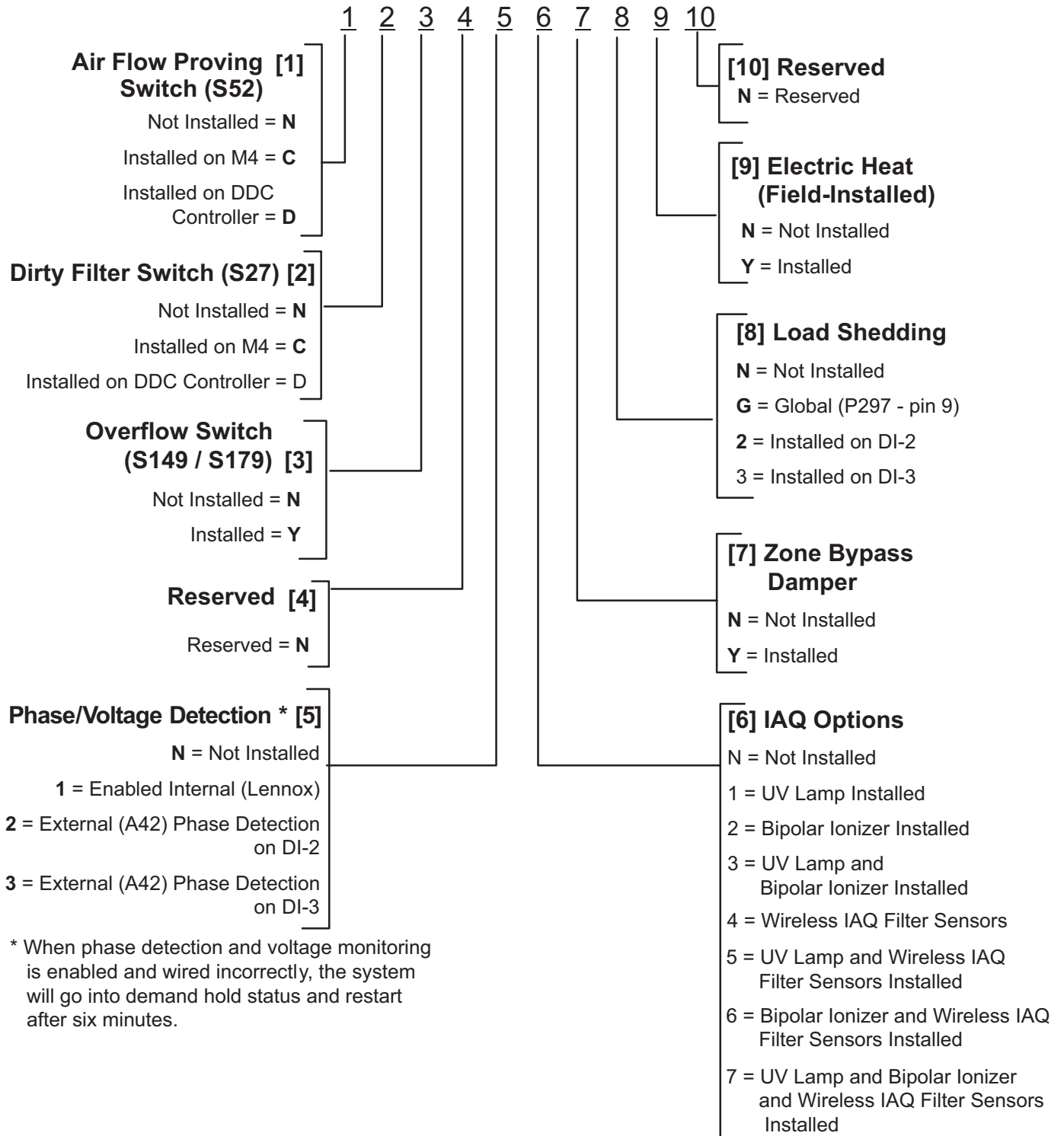

* When phase detection and voltage monitoring is enabled and wired incorrectly, the system will go into demand hold status and restart after six minutes.

FIGURE 36

START-UP REPORT

Job Name: _____
 Store No. _____ Start-Up Date: _____
 Address: _____
 City: _____ State: _____
 Start-Up Contractor: _____
 Technician: _____
 Model No.: _____
 Serial No.: _____
 RTU No.: _____ Catalog No.: _____

Inspections and Checks			
Damage?	Yes	No	R22 <input type="checkbox"/> R410A <input type="checkbox"/>
If yes, reported to: _____			
Verify factory and field-installed accessories.			
Check electrical connections. Tighten if necessary.			
Supply voltage: L1-L2 _____ L1-L3 _____ L2-L3 _____			
If unit contains a 208-230/240 volt transformer:			
Check primary transformer tap <input type="checkbox"/>			
Transformer secondary voltage: _____			

Cooling Checks												
Compressor Rotation <input type="checkbox"/> Ambient Temp. _____ Return Air Temp. _____ Supply Air Temp. _____												
	Compressor Amps			Compressor Volts			Pressures		Condenser Fan Amps			CC Heater Amps
	L1	L2	L3	L1-L2	L1-L3	L2-L3	Disch.	Suct.	L1	L2	L3	L1
1												
2												
3												
4												

Blower Checks			
Pulley/Belt Alignment <input type="checkbox"/>	Blower Rotation <input type="checkbox"/>		
Set Screws Tight <input type="checkbox"/>	Belt Tension <input type="checkbox"/>		
Nameplate Amps: _____		Volts: _____	
Motor	Amps	Volts	
	L1 _____	L1-L2 _____	
	L2 _____	L1-L3 _____	
	L3 _____	L2-L3 _____	

Heating Checks - Electric							
Return Air Temp.: _____ Supply Air Temp.: _____							
Limits Operate: <input type="checkbox"/>							
	Amps						
	L1	L2	L3		L1	L2	L3
1				10			
2				11			
3				12			
4				13			
5				14			
6				15			
7				16			
8				17			
9				18			

Heating Checks - Gas		
Fuel type: Nat. <input type="checkbox"/> LP <input type="checkbox"/> Inlet Pressure: _____ in. w.c.		
Return Air Temp.: _____ Supply Air Temp.: _____		
Altitude: _____ Primary Limits Operate: <input type="checkbox"/>		
CO ₂ %: _____		
Gas Valve	Manifold Pressure	
	Low Fire	High Fire
GV1		
GV2		

Accessory Checks	
Power Exhaust Amps	
1 _____	2 _____ None <input type="checkbox"/>
Economizer Operation	
Min. Pos. <input type="checkbox"/>	Motor travel full open/close <input type="checkbox"/>

Control Type