



\* US PATENTS 5188333, 5255887  
 CANADIAN PATENT 2073900  
 ADDITIONAL PATENTS PENDING

FEATURES:

- HEAVY GAUGE GALVANIZED STEEL CONSTRUCTION
- 2 x 3" WOOD PERIMETER NAILER
- PATENTED CLIPLOCK DESIGN FOR EASE OF ASSEMBLY
- NECESSARY HARDWARE ARE PROVIDE

ADJUSTABLE PITCH  
 \*CLIPLOCK 1000 ROOF CURB  
 TO SUIT



LGH036-072 / KGA024-072

CAT#	MODEL #	HEIGHT (inch)	HEIGHT (mm)	WEIGHT (lbs)
43W27	T1CURB20AN1-14-AP	14	355.6	113

MAXIMUM SLOPE PITCH IS 3/4" PER FOOT  
 IN ANY ONE DIRECTION.

REQUIRED DUCT SIZES

SUPPLY	18-5/8" x 20-15/32"
RETURN	11-31/32" x 31-11/32"

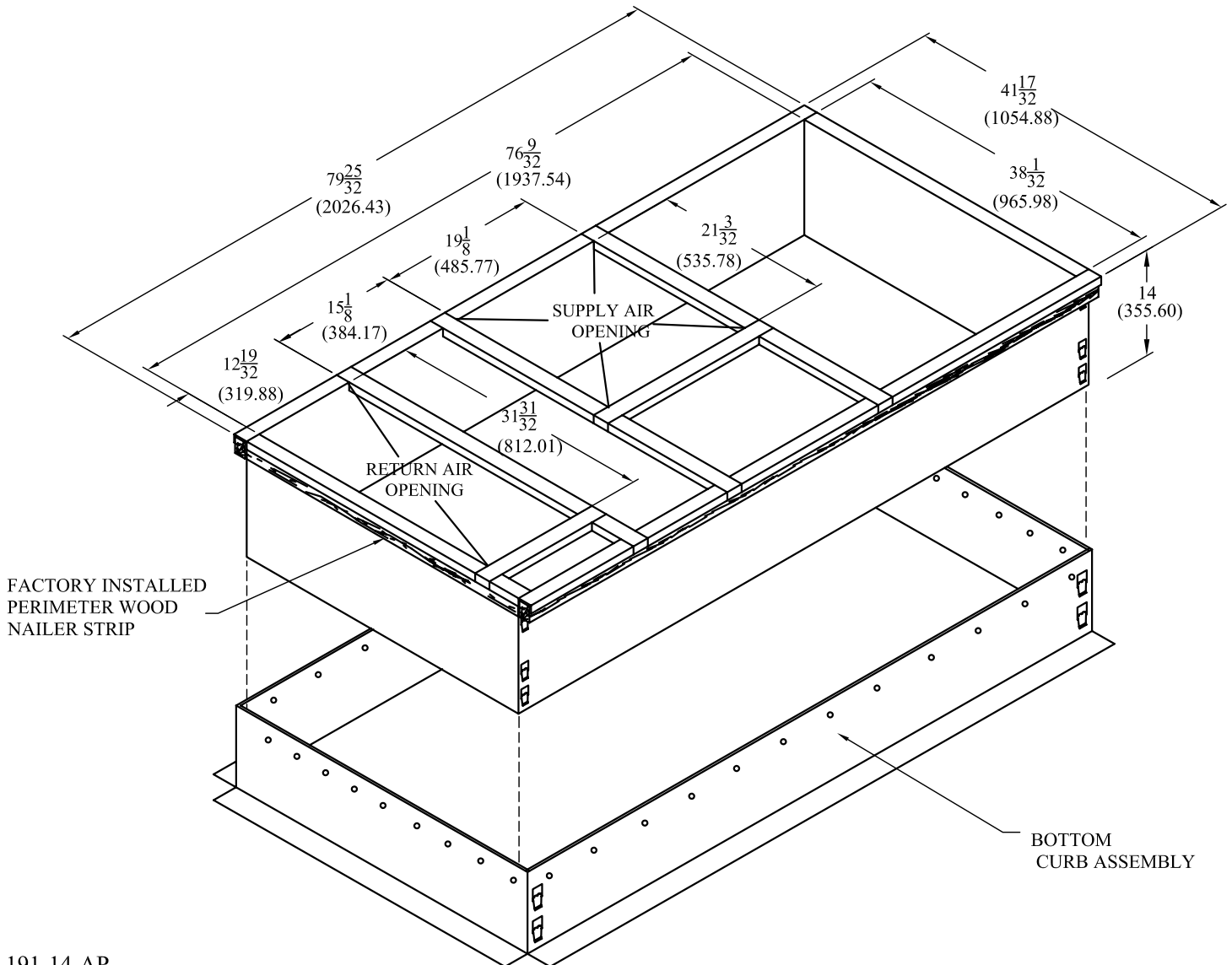

L191-14-AP  
 MAY 12, 2010

27 Leading Road Etobicoke, Ontario, Canada M9V 4B7  
 Tel: (416) 742-0598 Fax: (416) 742-4251  
 4846 Jennings Lane, Louisville, Kentucky, USA 40218  
 Tel: 1-800-932-6210 Fax: 1-800-903-7294

\* US PATENTS 5188333, 5255887  
 CANADIAN PATENT 2073900  
 ADDITIONAL PATENTS PENDING

## INSTALLATION INSTRUCTION ADJUSTABLE PITCH

### \*CLIPLOCK 1000 ROOF CURB

1. UNPACK ASSEMBLY AND VERIFY THAT ALL COMPONENTS ARE INCLUDED.
2. REFER TO PAGES 2 & 3 FOR INSTALL INSTRUCTIONS OF CLIPLOCK 1000 ROOF CURB.
3. ASSEMBLE UPPER CLIPLOCK CURB SIDE PIECES TO END PIECES.
4. ASSEMBLE LOWER CLIPLOCK SIDE PIECES TO END PIECES.
5. INSERT THE UPPER CURB ASSEMBLY INTO THE LOWER CURB ASSEMBLY.
6. TO LEVEL THE UPPER CURB ASSEMBLY, LIFT END UP SEE DETAIL FIG. 1
7. BEFORE SECURING THE TWO ASSEMBLIES TOGETHER, RE-CHECK THAT THE UPPER CURB IS LEVEL. THEN PLACE TWO SCREWS TO HOLD IT IN PLACE. SEE DETAIL FIG. 2
8. SCREW INTO PRE-PUNCHED HOLES ON THE LONG SIDES FIRST. STARTING ON ONE END AND MOVING UP TO THE OTHER END. ENSURE THAT THE TWO PIECES REMAIN PARALLEL .
9. ENSURE THAT ALL SCREW HOLES FOR ALL FOUR SIDES ARE COMPLETELY SCREWED IN.
10. SREWS PROVIDE WITH UNIT

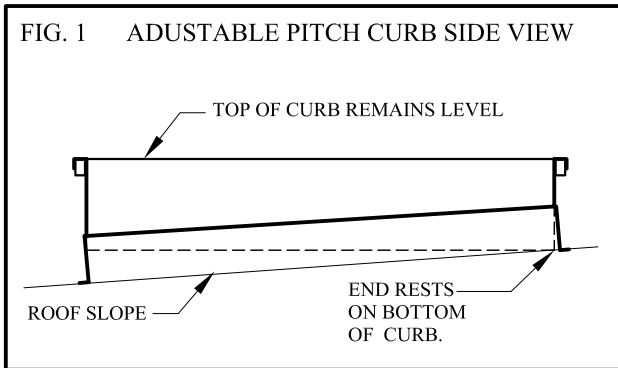

NOTE: MAXIMUM PITCH ADJUSTMENT IS 3/4" PER FOOT IN ANY ONE DIRECTION.

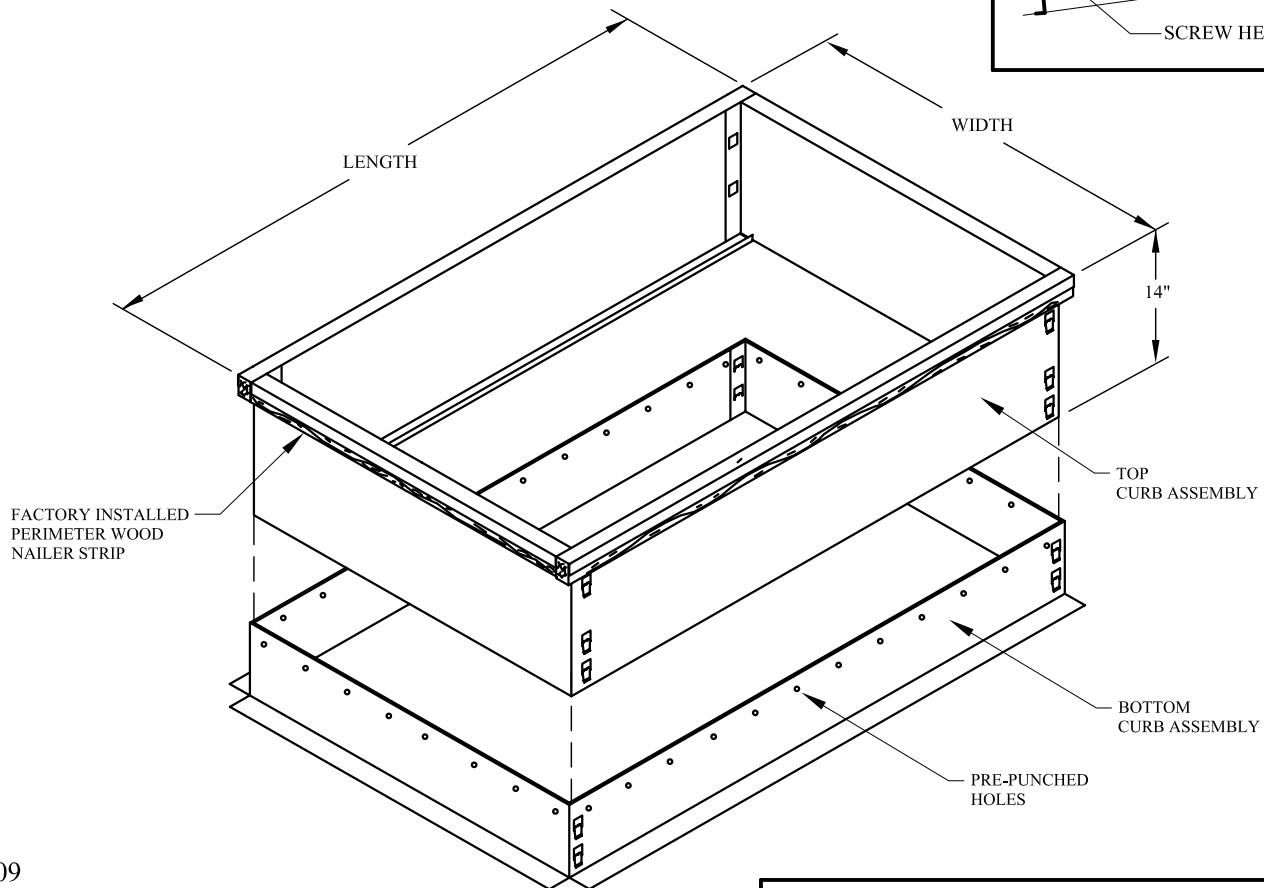
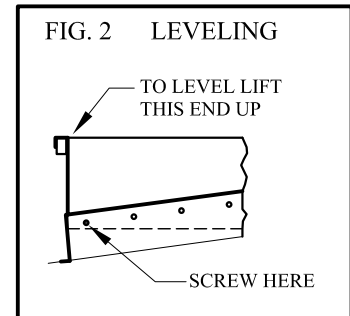

5000109  
 AUG 27 / 04

27 Leading Road Etobicoke, Ontario, Canada M9V 4B7  
 Tel: (416) 742-0598 Fax: (416) 742-4251  
 4846 Jennings Lane, Louisville, Kentucky, USA 40218  
 Tel: 1-800-932-6210 Fax: 1-800-903-7294

# INSTALLATION INSTRUCTION

## \*CLIPLOCK 1000 ROOF CURB

### CURB VERIFICATION

PRIOR TO FRAME FINAL ASSEMBLY AND INSTALLATION, VERIFY THAT ALL THE DIMENSIONS AND MODEL NUMBER DESIGNATIONS MATCH THOSE SHOWN ON THE ENCLOSED DRAWING. NOTIFY THE FACTORY OF ANY DISCREPANCIES. THE MANUFACTURER WILL NOT ASSUME ANY LIABILITIES OR COSTS AS THE RESULT OF ANY OF THE PROCEDURES LISTED IN THIS INSTRUCTION NOT BEING FOLLOWED AS DIRECTED.

\* US PATENTS 5188333, 5255887  
CANADIAN PATENT 2073900  
ADDITIONAL PATENTS PENDING

### FRAME ASSEMBLY

- STEP #1 TAKE ONE END PIECE (LOCKING TABS) AND ONE SIDE PIECE (SLOTS), STAND BOTH PIECES VERTICALLY ON FLOOR OR ROOF.
- STEP #2 RAISE SLIGHTLY THE CORNER OF THE END PIECE (LOCKING TABS) AND MATE WITH SIDE PIECE (SLOTS), ENSURING THAT LOWER LOCKING TAB WITH LEADING EDGE IS THROUGH SLOT OPENING. REFER TO FIG.#1.
- STEP #3 PUSH DOWN ON TOP EDGE OF END PIECE. ENSURE THAT ALL 3 OF THE LOCKING TABS ARE FEEDING INTO EACH CORRESPONDING SLOT. ONCE BOTH PIECES ARE FLUSH THE PROCESS IS COMPLETE. REFER TO FIG.#2.
- STEP #4 DRIVE ONE SPIKE PROVIDED INTO WOOD NAILER STRIPS AT EACH CORNER. REFER TO FIG.#3.

### INSTALL DUCT SUPPORT

#### SUPPLY / RETURN TRANSITION KIT

NOTE: IF SUPPLY / RETURN TRANSITION KITS ARE TO BE INSTALLED IN THE FUTURE, RELOCATE DUCT SUPPORTS AS PER INFORMATION PROVIDED IN SUPPLY / RETURN TRANSITION KIT.

PLACE DUCT SUPPORT CHANNELS IN THE LOCATIONS NOTED ON THE ENCLOSED DRAWING, THESE CHANNELS ARE PROVIDED WITH PRE PUNCHED HOLES TO ASSIST IN THE FASTENING PROCESS, HOWEVER IT WILL BE NECESSARY TO FIELD MEASURE THE FINAL LOCATION OF ALL CHANNELS (AS PER THE ENCLOSED DRAWING) PRIOR TO FASTENING IN PLACE WITH SCREWS PROVIDED. CONTACT THE FACTORY IF ANY DISCREPANCIES ARE APPARENT PRIOR TO THE MANUFACTURE OF THE DUCT OR INSTALLATION OF THE UNIT.

CAUTION:  
DUCT SUPPORT CHANNELS ARE MANUFACTURED TO SUPPORT THE WEIGHT OF DUCT DROPS ONLY, DO NOT WALK ON THESE AS THIS WILL CAUSE THE CHANNELS TO SAG AND CAUSE OPERATIONAL PROBLEMS WITH THE EQUIPMENT.

### FRAME APPLICATION AND LOCATION

THIS ROOF MOUNTING FRAME PROVIDES NECESSARY SUPPORT WHEN UNIT IS INSTALLED. THE FRAME CAN BE INSTALLED DIRECTLY ON DECK HAVING ADEQUATE STRUCTURAL STRENGTH OR ON ROOF SUPPORTS UNDER DECK.

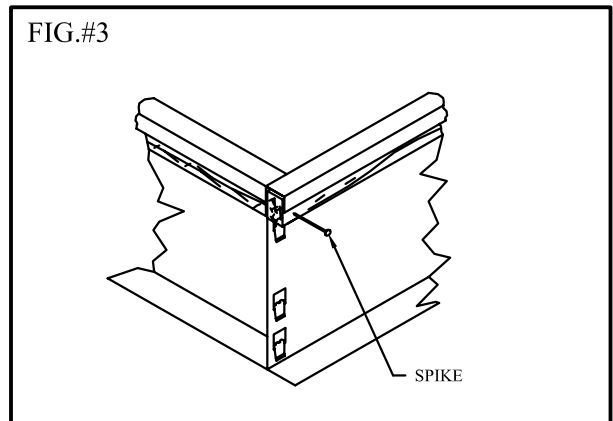
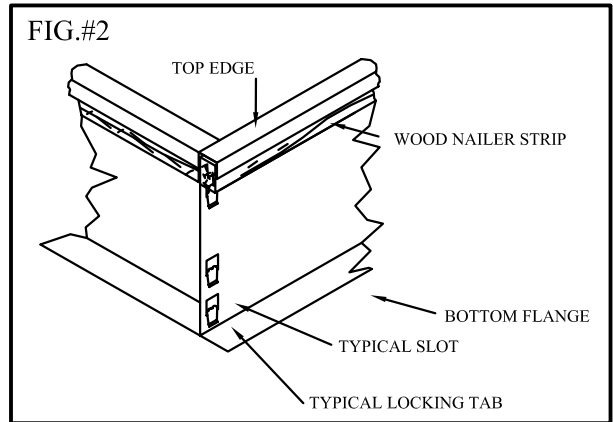
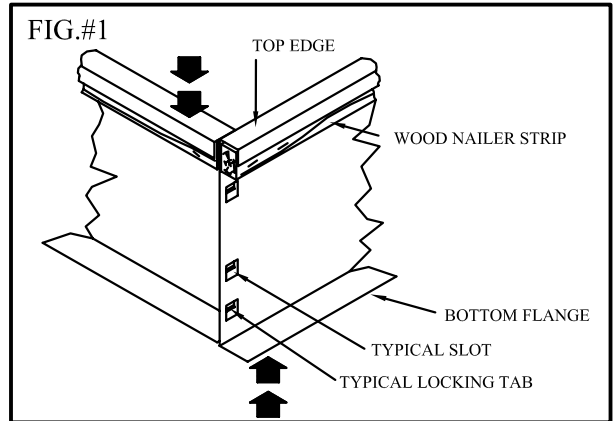

## SECURING FRAME

TO ASSURE PROPER MATING WITH UNIT, IT IS MANDATORY THE MOUNTING FRAME BE SQUARE TO ROOF STRUCTURE AS FOLLOWS:

- 1 - WITH FRAME SITUATED LEVEL IN DESIRED LOCATION ON ROOF TRUSSES, TACK WELD ONE CORNER OF FRAME.
- 2 - MEASURE FRAME DIAGONALLY FROM ONE CORNER AS SHOWN IN FIG.#4. THESE DIMENSIONS MUST BE EQUAL FOR FRAME TO SQUARE.
- 3 - IT IS EXTREMELY IMPORTANT TO SIGHT FRAME FROM ALL CORNERS TO MAKE CERTAIN FRAME IS NOT TWISTED ACROSS TOP SIDE. SHIM FRAME UNDER ANY LOW SIDES.
- 4 - AFTER FRAME HAS BEEN SQUARED, STRAIGHTENED AND SHIMMED, WELD OR ATTACH FRAME SECURELY TO ROOF.

MAXIMUM SLOPE TOLERANCE: 1/16" PER LINEAR FOOT IN ANY DIRECTION.

\* US PATENTS 5188333, 5255887  
CANADIAN PATENT 2073900  
ADDITIONAL PATENTS PENDING

### IMPORTANT: SQUARING FRAME

FRAME IS SQUARE WHEN CORNERS 1 TO 2 AND 3 TO 4 ARE EQUAL

IF A POURED ROOF IS USED, SUCH AS CONCRETE, BE SURE INSIDE OF MOUNTING FRAME IS ADEQUATELY BRACED TO ENSURE A SQUARE AND LEVEL FRAME.

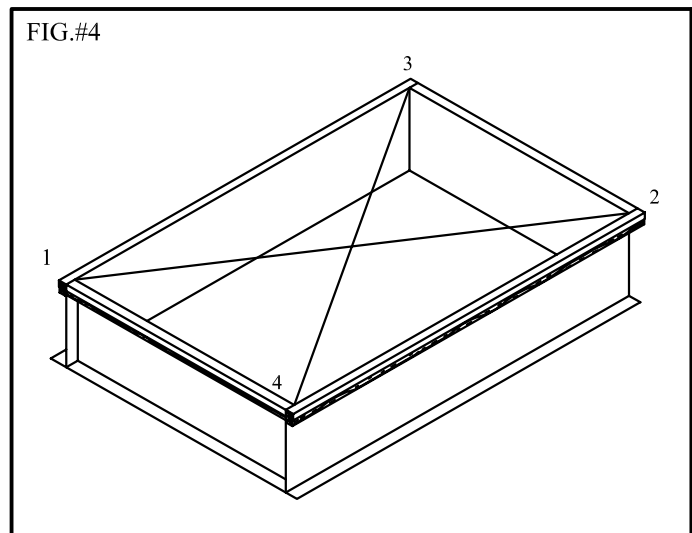

## CURBING AND FLASHING

- 1 - OUTSIDE OF FRAME SHOULD BE INSULATED WITH A RIGID TYPE INSULATION, PREFERABLY 2 IN. (51mm) THICK. DO NOT USE COMBUSTIBLE MATERIAL FOR FILLING AROUND FRAME.
- 2 - COUNTERFLASH AND SEAL AROUND FRAME AS SHOWN IN FIG.#5.

