

PACKAGED HEAT PUMP



LDT
Enlight™ Rooftop Units
Dual-Fuel - High Efficiency - 60 Hz

COMMERCIAL
PRODUCT SPECIFICATIONS

Bulletin No. 210982
 December 2023
 Supersedes all previous versions

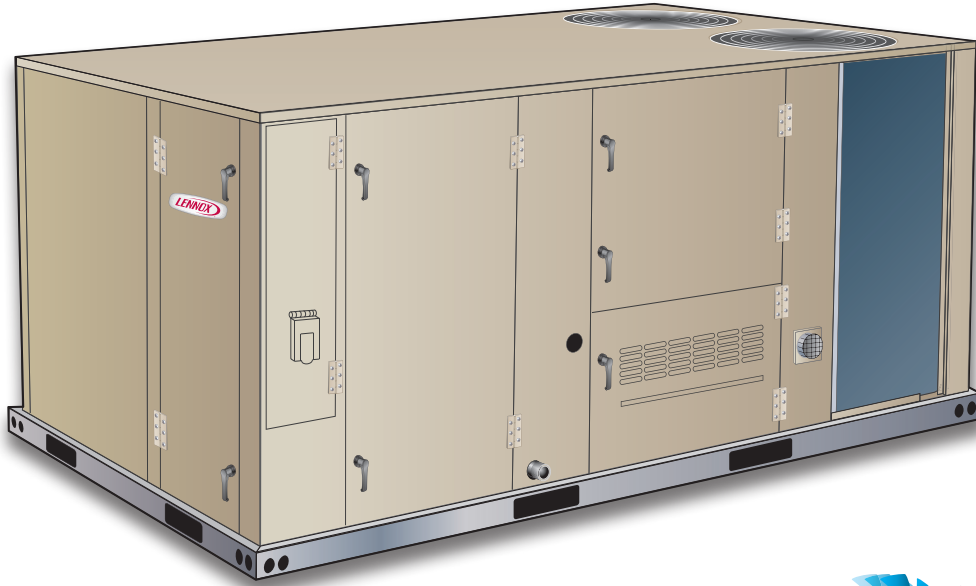

ENLIGHT



CORE
CONTROL SYSTEM

SMARTWIRE™ SYSTEM



ASHRAE 90.1
COMPLIANT

6.5 to 12.5 Tons

Net Cooling Capacity - 78,000 to 136,000 Btuh

Net Heating Capacity - 73,000 to 128,000 Btuh

Gas Input Heat Capacity - 130,000 to 240,000 Btuh

MODEL NUMBER IDENTIFICATION

LDT102H4ES1Y

Brand/Family
 L = Enlight™

Unit Type
 D = Packaged Dual-Fuel (Heat Pump/Gas Heating) Unit

Major Design Sequence
 T = 1st Generation

Nominal Cooling Capacity - Tons
 078 = 6.5 Tons
 092 = 7.5 Tons
 102 = 8.5 Tons
 122 = 10 Tons
 150 = 12.5 Tons

Cooling/Heating Efficiency
 H = High Efficiency

Refrigerant Type
 4 = R-410A

Voltage
 Y = 208/230V-3 phase-60Hz
 G = 460V-3 phase-60Hz
 J = 575V-3 phase-60Hz

Minor Design Sequence
 1 = 1st Revision

Heating Type
 S = Standard Gas Heat, 2 Stage
 M = Medium Gas Heat, 2 Stage
 H = High Gas Heat, 2 Stage

Blower Type
 E = MSAV® Multi-Stage Air Volume (DirectPlus™ ECM Direct Drive)

FEATURE HIGHLIGHTS

Lennox' Enlight™ rooftop units featuring the Lennox® CORE Control System create a bright future through a highly energy-efficient and environmentally sustainable design. Comprehensive configurations meet a wide range of applications, making it the most flexible product line Lennox has to offer.

1. Scroll Compressors
2. Check/Thermal Expansion Valves
3. Reversing Valve
4. Filter/Driers
5. Copper Tube Coil Construction
6. Outdoor Coil Fan Motors
7. Heat Exchanger/Inshot Burners
8. Heavy Gauge Steel Cabinet
9. Cabinet Insulation
10. Hinged Access Panels
11. DirectPlus™ Direct Drive ECM Blower System
12. Air Filters
13. Lennox® CORE Control System

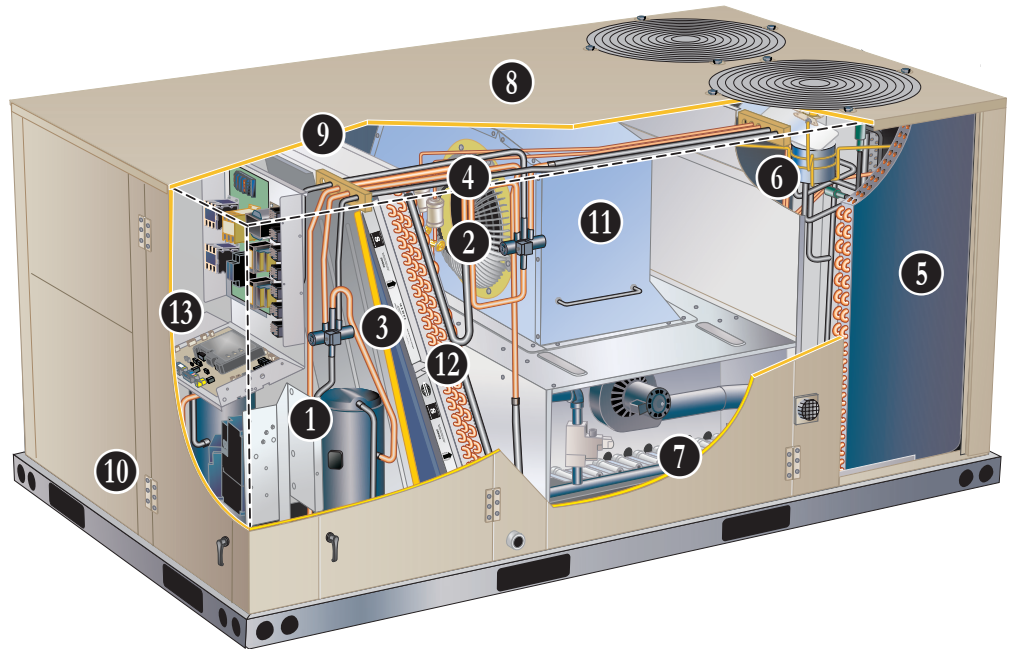

CONTENTS

Approvals And Warranty	3
Blower Data	28
Control System	7
Control System	8
Cooling/Heating Ratings	23
Dimensions	36
- 078 092 102	36
- 122 150	37
- Accessories	38
Electrical Data	31
- 6.5 Ton	31
- 7.5 Ton	31
- 8.5 Ton	32
- 10 Ton	32
- 12.5 Ton	33
Features And Benefits	3
High Altitude Derate	22
Model Number Identification	1
Optional Conventional Temperature Control Systems	12
Options / Accessories	17
Outdoor Sound Data	34
Sequence Of Operation	14
Sequence Of Operation	16
Specifications	20
- 6.5 Ton 7.5 Ton 8.5 Ton	20
- 10 Ton 12.5 Ton	21
- Gas Heat	22
Unit Clearances	34
Weight Data	35
- Options / Accessories	35
- Unit	35

APPROVALS AND WARRANTY

APPROVALS

- AHRI Standard 340/360 certified
- ETL and CSA listed
- Efficiency rating certified by CSA
- Unit and components are ETL, NEC, and CEC bonded for grounding to meet safety standards for servicing
- All models are ASHRAE 90.1 compliant
- All models meet DOE 2023 energy efficiency standards
- All models meet California Code of Regulations, Title 24 and ASHRAE 90.1-2022 Section 6.4.3.10 requirements for staged airflow
- ISO 9001 Registered Manufacturing Quality System

WARRANTY

- Compressors - Limited five years
- Lennox® CORE Unit Controller - Limited three years
- Stainless Steel Heat Exchanger - Limited fifteen years
- High Performance Economizers (optional) - Limited five years
- All other covered components - Limited one year

FEATURES AND BENEFITS

DUAL-FUEL OPERATION

(Heating Mode)

- Operates the heat pump for 1st stage heating
 - If 1st stage heat settings are not met, the 2nd stage activates gas heating (secondary heat source)
- Mechanical heat pump operation automatically terminates on gas heat start-up
- Lennox® CORE Control System automatically changes blower speeds between heat pump heating and gas heating
- Blower operates in high speed during 1st stage (heat pump) operation and terminates during changeover to gas heat operation
- Blower starts when heat exchanger is warm, and runs in high speed during 2nd stage (gas heat) operation
 - If continuous blower operation is available on the thermostat, a change in blower speed automatically occurs during heat pump to gas heat changeover

COOLING/HEATING SYSTEM

- Designed to maximize sensible and latent cooling performance at design conditions
- System can operate in the cooling mode from 0°F to 125°F without any additional controls

R-410A Refrigerant

- Non-chlorine based
- Ozone friendly

1 Compressor System

- System consists of one two-stage scroll compressor and one single-stage scroll compressor
- Resiliently mounted on rubber grommets for quiet operation

Compressor Crankcase Heaters

- Protects against refrigerant migration that can occur during low ambient operation

2 Check/Thermal Expansion Valves

- Ensures optimal performance throughout the application range
- Removable element head

3 Reversing Valve

- 4-way interchange reversing valve rapidly changes the direction of refrigerant flow resulting in quick changeover from cooling to heating and vice versa

4 Filter/Driers

- High capacity filter/drier protects the system from dirt and moisture

High Pressure Switches

- Protects the compressors from overload conditions
- Auto-reset

Low Pressure Switches

- Protects the compressors from low pressure conditions such as low refrigerant charge or low/no airflow

Indoor Coil Freeze Protection

- Protects the indoor coil from damaging ice build-up due to conditions such as low/no airflow, or low refrigerant charge

5 Coil Construction

- Copper tube construction
- Enhanced rippled-edge aluminum fins
- Flared shoulder tubing connections
- Silver soldered construction
- Factory leak tested

Indoor Coil

- Cross row circuiting
- Rifled copper tubing

Outdoor Coil

- Two independent formed coils allow separation for cleaning

FEATURES AND BENEFITS

COOLING / HEATING SYSTEM (continued)

Anti-Microbial Condensate Drain Pan

- Composite pan, sloped to meet drainage requirements per ASHRAE 62.1
- Anti-Microbial additive prevents growth of mold and mildew, which improves indoor air quality and reduces drain line blockage
- Side or bottom drain connections
- Reversible to allow connection at back of unit

6 Outdoor Coil Fan Motors

- All models have variable speed (ECM) fan motors for energy efficient operation and quiet operation
- Thermal overload protected
- Totally enclosed
- Permanently lubricated ball bearings
- Shaft up
- Wire basket mount

Outdoor Coil Fan

- PVC coated fan guards furnished

Required Selections

Cooling Capacity

- Specify nominal cooling capacity

Options/Accessories

Factory or Field Installed

Drain Pan Overflow Switch

- Monitors condensate level in drain pan
- Shuts down unit if drain becomes clogged

Field Installed

Condensate Drain Trap

- Constructed of PVC or copper

GAS HEATING SYSTEM

- Aluminized steel inshot burners
- Direct spark ignition
- Electronic flame sensor
- Combustion air inducer
- Redundant automatic dual stage gas valve with manual shut-off

7 Heat Exchanger

- Tubular construction, stainless steel
- Life cycle tested

Electronic Pilot Ignition

- Electronic spark igniter provides positive direct ignition of burners on each operating cycle
- Permits main gas valve to stay open only when the burners are proven to be lit
 - If loss of flame occurs, gas valve closes, shutting off the gas to the burners
- LED indicates status and aids in troubleshooting

- Watchguard circuit on module automatically resets ignition controls after one hour of continuous thermostat demand after unit lockout, eliminating nuisance service calls
- Factory installed in the gas heating compartment

Limit Control

- Redundant limit controls with fixed temperature setting
- Protects heat exchanger and other components from overheating

Safety Switches

- Flame roll-out switch
- Flame sensor
- Combustion air inducer proving switch
- Protects system operation

Required Selections

Gas Input Choice - Order one:

- Standard Gas Heat, 2 Stage (84,500/130,000 Btuh)
- Medium Gas Heat, 2 Stage (117,000/180,000 Btuh)
- High Gas Heat, 2 Stage (156,000/240,000 Btuh)

Options/Accessories

Field Installed

Bottom Gas Piping Kit

- Allows bottom gas entry

Combustion Air Intake Extensions

- Recommended for use with existing flue extension kits in areas where high snow areas can block intake air

Low Temperature Vestibule Heater

- Electric heater automatically controls minimum temperature in gas burner compartment when temperature is below -40°F
- CSA certified to allow operation of unit down to -60°F

LPG/Propane Kits

- Conversion kit to field change over units from Natural Gas to LPG/Propane

Options/Accessories

Field Installed

Vertical Vent Extension Kit

- Use to exhaust flue gases vertically above unit
- Required when unit vent is too close to fresh air intakes per building codes
- Also prevents ice formation on intake louvers
- Kit contains vent transition, vent tee, drain cap and installation hardware

NOTE - Straight vent pipes (4 in. B-Vent) and caps are not furnished and must be field supplied. Refer to kit instructions for additional information.

FEATURES AND BENEFITS

CABINET

8 Construction

- Heavy-gauge steel panels
- Full perimeter heavy-gauge galvanized steel base rail
- Base rails have rigging holes
- Three sides of the base rail have fork slots
- Raised edges around duct and power entry openings in the bottom of the unit for water protection

Airflow Choice

- Units are shipped in downflow (vertical) configuration

NOTE - Units can be field converted to horizontal airflow with optional Horizontal Discharge Kit.

Duct Flanges

- Provided for horizontal duct attachment

Power Entry

- Electrical lines can be routed through the unit base or through horizontal access knock-outs

Exterior Panels

- Constructed of heavy-gauge, galvanized steel
- Textured pre-paint with polyurethane finish
- Cyclic salt fog and UV exposure up to 1680 hours per ASTM D5894

9 Insulation

- Fully insulated with non-hygroscopic fiberglass insulation (conditioned areas)
- Unit base is fully insulated
- Base insulation serves as an air seal to the roof curb, eliminating the need to add a seal during installation

Access Panels

- Filter section
- Heating/blower section
- Compressor/controls section

Options/Accessories

Factory or Field Installed

Return Air Adaptor Plate

- For same size LC/LG/LH and TC/TG/TH unit replacement
- Installs on return air opening in unit to match return air opening on existing roof curbs
- Also see Accessory Air Resistance table

Combination Coil/Hail Guards

- Heavy gauge steel frame
- Painted to match cabinet
- Expanded metal mesh protects outdoor coil

Factory Installed

Corrosion Protection

- Completely flexible immersed coating
- Electrodeposited dry film process (AST ElectroFin E-Coat)
- ASTM B117 / DIN 53167 Salt Spray - 15,000+ hours
- ASTM G85 Annex A3 SWAAT Modified Salt Spray - 3,000 hours
- VA Master Construction Specification Division 23 for High Humidity Installations
- CID AA-52474A (GSA)
- Indoor Corrosion Protection:
 - Coated coil
 - Painted blower housing
 - Painted base
- Outdoor Corrosion Protection:
 - Coated coil
 - Painted outdoor base

10 Hinged Access Panels

- Tool-less access
- Filter section
- Blower/heating section
- Compressor/controls section
- Panel seals and quarter-turn latching handles provide a tight air and water seal

Field Installed

Horizontal Discharge Kit

- Consists of duct covers to block off downflow supply and return air openings for horizontal applications
- Also includes return air duct flanges for end return air when economizer is used in horizontal applications

NOTE - When configuring unit for horizontal application with economizer, a separate Horizontal Barometric Relief Damper with Hood must be ordered separately for installation in the return air duct.

FEATURES AND BENEFITS

BLOWER

11 DirectPlus™ Blower System

- High-efficiency, variable-speed ECM (electronically commutated) motor
- Eliminates the need for a separate variable-frequency drive
- MSAV® Multi-Stage Air Volume control modulates the amount of supply blower airflow according to cooling demand, heating demand, ventilation demand or smoke alarm
- The amount of airflow for each stage can be set according to a parameter in the Lennox® CORE Unit Controller
- Unit is shipped from the factory with preset airflows
- Fully variable speed motor modulates to maximize system efficiency
- Combines the motor and electronics into one unit
- Aerodynamically optimized impeller
- Backward curved blades mounted directly onto the rotor



- Air inlet grill reduces indoor sound levels without affecting air performance

ELECTRICAL

SmartWire™ System

- Keyed and color-coded wiring connectors prevent miswiring
- Wire coloring scheme is standardized across all models
- Each connection is intuitively labeled to make troubleshooting and servicing quick and easy

Electrical Plugs

- Positive connection electrical plugs are used to connect common accessories or maintenance parts for easy removal or installation

Phase/Voltage Detection

- Monitors power supply to ensure correct phase at unit start-up
 - If phase is incorrect, the unit will not start and an alarm code reports to the unit controller
- Prevents unit start-up if the unit is the incorrect phase; unit start-ups in the wrong phase could lead to issues such as compressors functioning in reverse
- Monitors power supply voltage to ensure proper voltage
 - If voltage is not correct (over/under voltage conditions) the unit will not start and an alarm code reports to the unit controller

Required Selections

Voltage Choice

- Specify when ordering base unit

Options/Accessories

Factory Installed

Circuit Breakers

- HACR type
- For overload and short circuit protection
- Factory wired and mounted in the power entry panel
- Current sensitive and temperature activated
- Manual reset

Short-Circuit Current Rating (SCCR)

- Higher short-circuit protection up to 100kA

NOTE - Disconnect Switch is not available as an option with High SCCR option.

Factory or Field Installed

Disconnect Switch

- Accessible from outside of unit
- Spring loaded weatherproof cover furnished

12 GFI Service Outlets (2)

- 115V ground fault circuit interrupter (GFCI) type options:
 - Factory installed, powered and wired
 - Factory installed, non-powered, field wired
 - Field installed, non-powered, field wired

Field Installed

GFI Weatherproof Cover

- Single-gang cover
- Heavy-duty UV-resistant polycarbonate case construction
- Hinged base cover with gasket

CONTROL SYSTEM

INDOOR AIR QUALITY

13 Air Filters

- Disposable 2 inch MERV 4 filters furnished as standard

Options/Accessories

Factory or Field Installed

Healthy Climate® High Efficiency Air Filters

- Disposable MERV 8 and MERV 13 (Minimum Efficiency Reporting Value based on ASHRAE 52.2) efficiency 2 inch pleated filters

Field Installed

Healthy Climate® High Efficiency MERV 16 Air Filters

- Disposable MERV 16 (Minimum Efficiency Reporting Value based on ASHRAE 52.2) efficiency 2 inch pleated filters

Healthy Climate® UVC Germicidal Light Kit

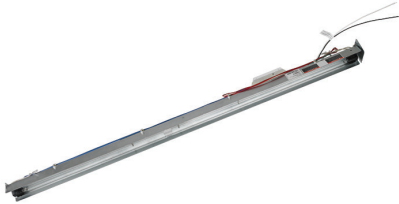

- Germicidal lamps emit ultra-violet (UV-C) energy, which has been proven to be effective in reducing microbes such as viruses, bacteria, yeasts, and molds
- UV-C energy greatly reduces the growth and proliferation of mold and other bioaerosols (bacteria and viruses) on illuminated surfaces (particularly coil and drain pan)
- Destroys the organism or controls its ability to reproduce
- Field installed in the blower/evaporator coil section
- Magnetic safety interlock terminates power when access panels are removed
- All necessary hardware for installation is included
- Lamps operate on 110/230V-1ph power supply

NOTE - Step-down transformer may be ordered separately for 460V and 575V units.

- Approved by ETL

Needlepoint Bipolar Ionization (NPBI) Kit

- NPBI technology integrates with system controls for effective air treatment
- Ionization has been shown to effectively reduce harmful pathogens, pollutants and odors

NOTE - Please visit www.sciencedirect.com for additional information.

- Brush-type ionizer introduces a high concentration of both positive and negative ions into the airstream
- The bipolar ions are then dispersed into the occupied space through the duct system proactively reducing the airborne contaminants
- Ions travel within the building air stream and attach to particles, pathogens, and gas molecules, making them larger and easier to capture in the filtration system
- UL 2998 certified for zero ozone emission

Indoor Air Quality (CO₂) Sensors

- Monitors CO₂ levels
- Reports to the Lennox® CORE Unit Controller, which adjusts economizer dampers as needed

Replacement Filter Media Kit With Frame

- Replaces existing pleated filter media
- Includes washable metal mesh screen and metal frame with clip for holding replaceable non-pleated filter

CONTROL SYSTEM

LENNOX® CORE CONTROL SYSTEM

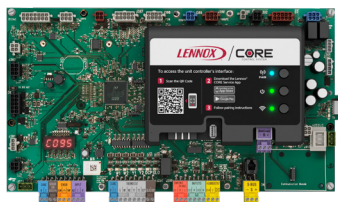

14 The Lennox® CORE Control System is designed to accelerate equipment install and service. Standard with all Enlight™ rooftop units, control system integrates key technologies that lower installation costs, drive system efficiency, and protect your investments.

The Lennox® CORE Unit Controller is a microprocessor-based controller that provides flexible control of all unit functions.

CORE Mobile Service App

- Guided Setup with progress indicators, detailed help, and exportable summaries to manage simple, trouble-free setup, reducing commissioning times
- Enhanced Test Functionality provides real-time sensor readings, trending, and reports that enable easy troubleshooting
- Ability to set and configure parameters of the Lennox® CORE Control System to manage sequence of operation
- Economizer test function ensures economizer is operating correctly



Additional Features:

- Built-In 7-Segment Display shows Unit Status and active alarms for easy troubleshooting
- Buttons for test and clearing delays
- SmartWire™ System with keyed and removable screw terminals ensure correct field wiring
- Built-in BACnet MS/TP and IP allow open integration to building management systems.
- Two-port Ethernet Switch enables daisy chaining for BACnet IP and automatic firmware updates

NOTE - Unit Internet Connection required.

- Profile setup copies key settings between units with the same configuration to reduce setup time
- USB port allows a technician to download and transfer unit information to help verify service was performed
- USB software updates on the Lennox® CORE Unit Controller enhance functionality without the need to change components
- Unit Controller Software

Configurable Built-In Functions

- Discharge Air Cooling Control
- Up to three distinct Cooling Airflows in Thermostat Mode
- Programmable independent heating, ventilation and cooling blower speeds
- Discharge Air Heating Control

- Economizer Control Options (See Economizer / Exhaust Air / Outdoor Air sections)
- Exhaust Fan Control Modes for fresh air damper position
- Configurable Morning Warm-up
- Night Setback Mode
- Fresh Air Tempering for Improved Ventilation
- Demand Control Ventilation
- Low Ambient Controls for operation down to 0°F
- Two Defrost Control Methods (demand and timed - packaged heat pumps only)

Component Protection / Unit Safeguards:

- Compressor Time-Off Delay
- Adjustable Blower On/Off Delay
- Return Air Temperature Limit Control
- Safety Switch Input allows Controller to respond to a external safety switch trip
- Service Relay Output
- Thermostat Bounce Delay
- Smoke Alarm Mode has four choices (unit off, positive pressure, negative pressure, purge)
- "Strike Three" Protection
- Gas Valve Time Delay Between First and Second Stage
- Minimum Compressor Run Time

Control Methods / Interfaces:

- DDC and 24V Thermostat
- BACnet MS/TP and IP
- LONTalk (Factory and Field Option)
- Lennox S-BUS
- Compatibility with Lennox Wireless Zone Sensors
- Zone Temperature Sensor Input
- Dehumidistat and Humidity Sensor Inputs
- Indoor Air Quality Inputs (2)
- Built-in Control Parameter Defaults
- Permanent Diagnostic Code Storage
- Field Adjustable Control Parameters (Over 200 settings)
- Multiple Configurable Digital Inputs
- LED Indicators
- PC Interface connects the Lennox® CORE Unit Controller to a PC with the Lennox Unit Controller Software

NOTE - Lennox® CORE Control System features vary with the type of rooftop unit in which the control is installed.

OPTIONS / ACCESSORIES

LENNOX® CORE CONTROL SYSTEM (continued)

Controls Options

Factory or Field Installed

Blower Proving Switch

- Monitors blower operation, shuts down unit if blower fails

Dirty Filter Switch

- Senses static pressure increase and issues alarm if necessary

Fresh Air Tempering

- Used in applications with high outside air requirements
- Controller energizes the first stage heat as needed to maintain a minimum supply air temperature for comfort, regardless of the thermostat demand
- When ordered as a factory option, sensor ships with the unit for field installation

Smoke Detector

- Photoelectric type
- Installed in supply air section, return air section or both sections
- Available with power board and single sensor (supply or return) or power board and two sensors (supply and return)
- Power board located in unit control compartment

Interoperability via BACnet® or LonTalk® Protocols

- Communication compatible with third-party automation systems that support the BACnet Application Specific Controller device profile, LonMark® Space Comfort Controller functional profile, or LonMark Discharge Air Controller functional profile

ECONOMIZER

- Economizer operation is set and controlled by the Lennox® CORE Control System
- Simple plug-in connections from economizer to control system for easy installation
- All Enlight™ rooftop units are equipped with factory installed CEC Title 24 approved sensors for outside, return and discharge air temperature monitoring

NOTE - Optional sensors may be used instead of unit sensors to determine whether outdoor air is suitable for free cooling. See the Options/Accessories table.

Factory or Field Installed

High Performance Economizer

- Approved for California Title 24 building standards
- Low leakage dampers are Air Movement and Control Association International (AMCA) Class 1A Certified - Maximum 3 CFM per sq. ft. leakage at 1 in. w.g.
- ASHRAE 90.1 compliant
- Downflow or Horizontal with Outdoor Air Hood
- Outdoor Air Hood is included when economizer is factory installed and is furnished with economizer when ordered for field installation
- Linked damper action
- High torque 24-volt fully-modulating spring return damper motor
- Return air and outdoor air dampers
- Plug-in connections to unit
- Barometric Relief Dampers with Exhaust Hood are also furnished

NOTE - Horizontal applications use furnished outdoor air hood and barometric relief dampers with exhaust hood. Requires optional Horizontal Discharge Kit. See dimension drawing on Page 39

Horizontal applications in reduced spaces requires optional Horizontal Low Profile Barometric Relief Dampers with Exhaust Hood and Horizontal Discharge Kit. See dimension drawing on Page 40

NOTE - High Performance Economizers are not approved for use with enthalpy controls in Title 24 applications.

NOTE - The Free Cooling setpoint for Title 24 applications must be set based on the Climate Zone where the system is installed. See Section 140.4 "Prescriptive Requirements for Space Conditioning Systems" of the California Energy Commission's 2022 Building Energy Efficiency Standards.

NOTE - Refer to Installation Instructions for complete setup information.

OPTIONS / ACCESSORIES

ECONOMIZER (continued)

Factory or Field Installed (continued)

Differential Sensible Control

- Factory setting
- Uses outdoor air and return air sensors that are furnished with the unit
- The Lennox® CORE Control System compares outdoor air temperature with return air and activates the economizer when the outdoor air is below the configured setpoint and cooler than return air

NOTE - Differential Sensible Control can be configured in the field to provide Offset Differential Sensible Control or Single Sensible Control.

In Offset Differential Sensible Control mode, the economizer is enabled if the temperature differential (offset) between outdoor air and return air reaches the configured setpoint.

In Single Sensible Control mode, the economizer is enabled when outdoor air temperature falls below the configured setpoint.

Global Control

- The unit controller communicates with a DDC system with one global sensor (enthalpy or sensible)
- Determines whether outside air is suitable for free cooling on all units connected to the control system
- Sensor must be field provided

Single Enthalpy Temperature Control (Not for Title 24)

- Outdoor air enthalpy sensor enables economizer if the outdoor enthalpy is less than the setpoint of the control

Differential Enthalpy Control (Not for Title 24)

- Order two Single Enthalpy Controls
- One is field installed in the return air section
- One is installed in the outdoor air section
- Allows the economizer control to select between outdoor air or return air, whichever has lower enthalpy

Field Installed

Outdoor Air CFM Control

- Maintains constant outdoor air volume levels on the supply air fan and varying unit airflows
- Velocity sensor located in the rooftop unit outdoor air section, the Lennox® CORE Control system changes the economizer position to help minimize the effect of supply fan speed changes on outdoor air volume levels
- Setpoint for outdoor air volume is established by field testing

NOTE - Not available with Demand Control Ventilation (CO₂ Sensor) or Building Pressure Control.

Building Pressure Control

- Maintains constant building pressure level
- Includes a static pressure transducer and outdoor static pressure assembly
- Using differential pressure information between the outdoor air and the building air, the Lennox® CORE Control system changes the economizer position to help maintain a constant building pressure

NOTE - Not available with Demand Control Ventilation (CO₂ Sensor) or Outdoor Air CFM Control.

EXHAUST

Factory or Field Installed

Power Exhaust Fan

- Installs internal to unit for downflow applications only with economizer option
- Provides exhaust air pressure relief
- Interlocked to run when supply air blower is operating
- Fan runs when outdoor air dampers are 50% open (adjustable)
- Motor is overload protected
- Fan is 20 in. diameter
- Five blades
- One 1/3 hp motor

NOTE - Requires Economizer and Downflow Barometric Relief Dampers

Field Installed

Horizontal Low Profile Barometric Relief Dampers

- For use when unit is configured for horizontal applications requiring an economizer in a reduced space
- Allows relief of excess air
- Aluminum blade dampers prevent blow back and outdoor air infiltration during off cycle
- Field installed in return air duct
- Bird screen and hood furnished

NOTE - Requires Horizontal Discharge Kit.

OPTIONS / ACCESSORIES

OUTDOOR AIR

Factory or Field Installed

Outdoor Air Damper

- Downflow or Horizontal
- Linked mechanical dampers
- 0 to 25% (fixed) outdoor air adjustable
- Installs in unit
- Includes outdoor air hood
- Motorized model features fully modulating spring return damper motor with plug-in connection
- Manual model features parallel blade, gear-driven dampers with adjustable fixed position

NOTE - Manual Outdoor Air Damper is a field installed option only.

ROOF CURBS

Field Installed

- Nailer strip furnished (downflow only)
- Mates to unit
- US National Roofing Contractors Approved
- Shipped knocked down

Hybrid Roof Curbs, Downflow

- Interlocking tabs fasten corners together
- No tools required for assembly
- Can also be fastened together with furnished hardware
- Available in 8, 14, 18, and 24 inch heights

Adjustable Pitch Curb

- Fully adjustable pitch curbs (3/4 in. per foot in any direction) provide a level platform for rooftop units allowing flexible installations on roofs with uneven or sloped angles
- Interlocking tabs fasten corners together
- No tools required for assembly
- Hardware is furnished to connect upper curb with lower curb
- Available in 14 inch height

Adaptor Curbs (not shown)

- Curbs are regionally sourced
- Dimensions vary based upon the source

NOTE - Contact your local sales representative for a detailed cut sheet with applicable dimensions.

CEILING DIFFUSERS

Field Installed

Ceiling Diffusers

(Flush or Step-Down)

- White powder coat finish on diffuser face and grilles
- Insulated UL listed duct liner
- Diffuser box has collars for duct connection
- Step-down diffusers have double deflection blades
- Flush diffusers have fixed blades
- Provisions for suspending
- Internally sealed to prevent recirculation
- Removable return air grille
- Adapts to T-bar ceiling grids or plaster ceilings

Transitions (Supply and Return)

- Used with diffusers
- Installs in roof curb
- Galvanized steel construction
- Flanges furnished for duct connection to diffusers
- Fully insulated

OPTIONAL CONVENTIONAL TEMPERATURE CONTROL SYSTEMS

CS8500 Commercial 7-Day Programmable Thermostat

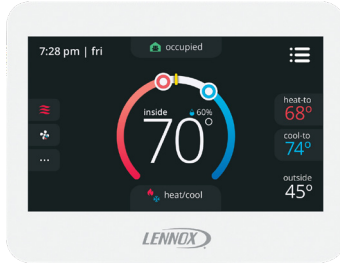

- Fully Communicating Sensor
- Full Color Touchscreen Interface
- Variable Speed System Control (On Compatible Units)
- Up To 4 Heat / 4 Cool
- Built-In Sensors For Temperature, Humidity And Optional CO₂
- Remote Sensor Options For Occupancy, Temperature
- BACnet Capable Options
- 5-2 or 7-Day Scheduling
- Smooth Setback Recovery
- Heat/Cool Auto-Changeover
- Four-Wire Installation
- FDD, ASHRAE, IECC Compliant

CS7500 Commercial 7-Day Programmable Thermostat



- Premium Universal Thermostat
- Full Color Touchscreen Interface
- Up To 4 Heat / 3 Cool
- Built-In Sensors For Temperature and Humidity
- Remote Sensors Options For Temperature, Discharge Air, Outdoor Air
- 5-2 or 7-Day Scheduling
- Smooth Setback Recovery
- Heat/Cool Auto-Changeover
- FDD, ASHRAE, IECC Compliant

CS3000 Commercial 5-2 Day Programmable Thermostat



- Conventional Multi-Stage Thermostat
- Intuitive Display
- Push-Button Operation
- Up To 2 Heat / 2 Cool
- Built-In Temperature Sensor
- Remote Temperature Sensing
- Up to 5-2 Day Scheduling
- Smooth Setback Recovery
- Heat/Cool Auto-changeover

Wireless/Wired Temperature/Humidity Room Sensor (LCS-5030)



- Simple Push-Button Override
- Variable Speed System Control (On Compatible Units)
- Up To 4 Heat / 4 Cool
- AA Battery / 24VAC Powered
- Bluetooth™ Mesh Operation
- SBUS Wired Operation
- Automatic Sensor Averaging
- Locking Hex Screw

Wireless Repeater for LCS-5030



- Extends Effective Range of Wireless Sensor (LCS-5030)
- 24VAC Only
- Locking Hex Screw

NOTE - Wireless only.

OPTIONAL CONVENTIONAL TEMPERATURE CONTROL SYSTEMS

Wired Temperature/Humidity Room Sensor (Non-Communicating)



- Terminal blocks for wiring connections
- Five-wire sensor connection
- Off-white plastic enclosure
- Non-adjustable
- Relative humidity range: 0 -100%
- +/- 3% Accuracy

OPTIONAL CONVENTIONAL TEMPERATURE CONTROL SYSTEMS

Description	Catalog No.
CS8500 Commercial 7 Day Programmable Thermostat	
CS8500 7-Day Thermostat	No CO ₂ Sensing 24K55
	With CO ₂ Sensing 24K53
Sensors/Accessories	¹ Remote non-adjustable wall-mount 10k 47W37
	¹ Remote non-adjustable wall-mount 11k 94L61
Sysbus Network Cable (Yellow) for CS8500 and LCS-5030 Wired Room Sensor	
Twisted pair 100% shielded communication cable, Red and Black	500 ft. box 27M19
22 AWG, yellow jacket, rated at 75°C, 300V, Plenum rated	1000 ft. box 94L63
Insulation - Low smoke PVC, NEC, CMP	2500 ft. roll 68M25
CS7500 Commercial 7-Day Programmable Thermostat	
CS7500 7-Day Thermostat	24K41
Sensors/Accessories	² Remote non-adjustable wall-mount 20k 47W36
	² Remote non-adjustable wall-mount 10k 47W37
	Remote non-adjustable discharge air (duct mount) 19L22
	Outdoor temperature sensor X2658
CS3000 Commercial 5-2 Day Programmable Thermostat	
CS3000 5-2 Day Thermostat	11Y05
Sensors/Accessories	Remote non-adjustable wall mount 10k averaging 47W37
	Thermostat wall mounting plate X2659
Universal Thermostat Guard with Lock (clear)	
	Inside Dimensions (H x W x D) 5-7/8 x 8-3/8 x 3 in. 39P21
Temperature/Humidity Room Sensors	
LCS-5030 Wireless/Wired Temperature/Humidity Room Sensor	21L07
Wireless Repeater for LCS-5030	21L09
A335MT13AE1 Wired Temperature/Humidity Room Sensor (Non-Communicating)	21W06

¹ Up to nine of the same type remote temperature sensors can be connected in parallel.

² Remote wall-mount sensors can be applied in any of the following combinations:

One Sensor - (1) 47W36, Two Sensors - (2) 47W37, Three Sensors - (2) 47W36 and (1) 47W37

Four Sensors - (4) 47W36, Five Sensors - (3) 47W36 and (2) 47W37

SEQUENCE OF OPERATION

Objective: Outline the unit functions as a result of room thermostat or zone sensor demands.

Given: When economizer is present, it will function as an integral part of the unit cooling system. When not present, unit will function as if economizer is present but outdoor ambient is high and sensed as not suitable.

UNIT OPERATION WITH 2-STAGE THERMOSTAT (2 COOL AND 2 HEAT STAGES, Y1, Y2, W1, W2)

Supply Air Blower Speed

Unit has following supply air blower speed setting:

- Ventilation speed
- Cooling Speed - Low
- Cooling Speed - High
- Heating speed
- Smoke speed (Used only in smoke removal option - not discussed)

¹ Unit Features An Economizer And Outdoor Air Is Suitable

Cooling - Thermostat Mode (Y1, Y2)

Y1 Demand:

All compressors are off, supply air blower is on low cooling speed to minimize blower power consumption, economizer modulates (minimum to maximum open position) to maintain 55°F supply air temperature (default unit controller setting).

Y2 Demand:

All compressors are off, supply air blower is on high cooling speed providing higher cooling capacity, and economizer modulates to maintain 55°F supply air temperature. If economizer stays at maximum open for 3 minutes, compressor 1 is energized while supply air blower stays on high cooling speed providing maximum cooling capacity.

¹ *Outdoor air suitability is determined by the energy state of outdoor ambient (enthalpy or sensible) and its ability to achieve the desired free cooling effects. Outdoor air suitability can also be determined by a third party controller and provided to the rooftop unit via a network connection.*

Unit Does Not Feature An Economizer Or Outdoor Air Is Not Suitable

Y1 Demand:

Compressor 1 operates, and supply air blower operates at low cooling speed.

Y2 Demand:

All compressors operate and supply air blower operates at high cooling speed.

SEQUENCE OF OPERATION

UNIT OPERATION WITH 3-STAGE THERMOSTAT OR ZONE SENSOR (3 COOL AND 2 HEAT STAGES, Y1, Y2, Y3 AND W1, W2)

Supply Air Blower Speed

Unit has following supply air blower speed setting:

- Ventilation speed
- Cooling Speed - Low
- Cooling Speed - Medium
- Cooling Speed - High
- Heating speed
- Smoke speed (Used only in smoke removal option - not discussed)

¹ Unit Features An Economizer And Outdoor Air Is Suitable

Cooling - Thermostat or Zone Sensor Mode (Y1, Y2, Y3)

Y1 Demand:

All compressors are off, supply air blower is on low cooling speed to minimize blower power consumption, economizer modulates (minimum to maximum open position) to maintain 55°F supply air temperature (default unit controller setting).

Y2 Demand:

All compressors are off, supply air blower is on high cooling speed providing higher cooling capacity, and economizer modulates to maintain 55°F supply air temperature. If economizer stays at maximum open for 3 minutes, compressor 1 is energized while supply air blower stays on high cooling speed providing maximum cooling capacity. After compressors are energized the economizer stays at maximum open.

Y3 Demand:

Compressors 1 and 2 are energized while supply air blower stays on high cooling speed.

¹ Outdoor air suitability is determined by the energy state of outdoor ambient (enthalpy or sensible) and its ability to achieve the desired free cooling effects. Outdoor air suitability can also be determined by a third party controller and provided to the rooftop unit via a network connection.

Unit Does Not Feature An Economizer or Outdoor Air Is Not Suitable

Y1 Demand:

Compressor 1 operates at part load and supply air blower operates at low cooling speed.

Y2 Demand:

Compressor 1 operates at part load with compressor 2 ON, and supply air blower operates at medium cooling speed.

Y3 Demand:

All compressors operate and supply air blower operates at high cooling speed.

Defrost Mode

Coil Sensors (RT48 - Circuit 1 and RT49 - Circuit 2) and Ambient Sensor (RT17) provides input to the Lennox® CORE Unit Controller to initiate a defrost cycle if needed.

Coil sensors are located on a return bend for each circuit on the front of the outdoor coil.

Ambient sensor is located on the inside of the corner mullion on the back of the outdoor coil section.

If a coil sensor measures a temperature below 35°F during mechanical heating mode, defrost logic is enabled. The system will constantly monitor coil and ambient temperatures and will initiate a defrost cycle if the controller determines that the target temperature difference between the coil and ambient temperature has been satisfied, or when the accumulated run time with coil temperature below 35°F reaches 6 hours.

Defrost will not be activated on more than one circuit at the time.

If the ambient sensor fails, or the circuit is in uncalibrated state, the controller will switch to time/temperature defrost operation.

Whichever circuit is not in a defrost cycle will be energized during to maintain discharge air temperature.

SEQUENCE OF OPERATION

Heating - Thermostat or Zone Sensor

W1 Demand:

A first-stage heating demand (W1) will activate the controller to check the Outdoor Air Temperature and Balance Point (default is 35°F). User adjustable from 10°F to 65°F.

If the Outdoor Air Temperature is more than the Balance Point, the controller will energize compressors 1 and 2 and the outdoor fans.

If the Outdoor Air Temperature is less than the Balance Point, the controller will lock out Mechanical Heating and will enable gas heat only.

NOTE – L1 and L2 reversing valves are de-energized in the heating mode.

W2 Demand:

A second-stage heating demand (W2) will de-energize Mechanical Heating and High Gas Heat will be energized.

OUTDOOR AIR DAMPER

The minimum damper position for “occupied low blower” and “occupied high blower” is adjusted during unit setup to provide minimum fresh air requirements per ASHRAE 62.1 at the corresponding supply air blower speeds.

When supply air blower is off or the unit is in unoccupied mode, the outdoor air damper is closed.

When unit is in occupied mode and supply air blower is operating at a speed below the “midpoint” blower speed, the outdoor air damper is at minimum “low blower” position.

When unit is in occupied mode and supply air blower is operating at a speed equal to or above the “midpoint” blower speed, the outdoor air damper is at minimum “high blower” position.

NOTE - The “midpoint” blower speed is an average of the minimum and maximum blower speed (minimum speed + maximum speed divided by 2).

POWER EXHAUST OPERATION

NOTE - POWER EXHAUST OPERATION IS THE SAME FOR ALL CONTROL OPTIONS

Single-stage power exhaust fan is an option available to units with Economizer and for downflow applications only.

Power exhaust fan operates when economizer outdoor air dampers are 50% open (adjustable) and when supply air blower is ON.

OPTIONS / ACCESSORIES

Item Description	Catalog Number	Unit Model No					
		078	092	102	122	150	
COOLING SYSTEM							
Condensate Drain Trap	PVC	22H54	X	X	X	X	X
	Copper	76W27	X	X	X	X	X
Drain Pan Overflow Switch		21Z07	OX	OX	OX	OX	OX
GAS HEATING SYSTEM							
Bottom Gas Piping Kit		54W95	X	X	X	X	X
Combustion Air Intake Extensions		19W51	X	X	X	X	X
Gas Heat Input	130,000 Btuh	Factory	O	O	O	O	O
	180,000 Btuh	Factory	O	O	O	O	O
	240,000 Btuh	Factory		O	O	O	O
Low Temperature Vestibule Heater	208/230V-3ph	22A51	X	X	X	X	X
	460V	22A55	X	X	X	X	X
	575V	13X65	X	X	X	X	X
LPG/Propane Conversion Kits	Standard Heat	14N22	X	X	X	X	X
	Medium Heat	14N23	X	X	X	X	X
	High Heat	14N25	X	X	X	X	X
Vertical Vent Extension		42W16	X	X	X	X	X
BLOWER - SUPPLY AIR							
Blower Option	DirectPlus™ Blower System with MSAV®	Factory	O	O	O	O	O
CABINET							
Combination Coil/Hail Guards		24C86	OX	OX	OX		
		24C87				OX	OX
Corrosion Protection		Factory	O	O	O	O	O
Horizontal Discharge Kit		51W25	X	X	X	X	X
Return Air Adaptor Plate (for LC/LG/LH and TC/TG/TH unit replacement)		54W96	OX	OX	OX	OX	OX
CONTROLS							
Blower Proving Switch		21Z10	OX	OX	OX	OX	OX
Commercial Controls	CPC Einstein Integration	Factory	O	O	O	O	O
	LonTalk® Module	54W27	OX	OX	OX	OX	OX
	Novar® LSE	Factory	O	O	O	O	O
Dirty Filter Switch		53W67	OX	OX	OX	OX	OX
Fresh Air Tempering		21Z08	OX	OX	OX	OX	OX
Smoke Detector - Supply or Return (Power board and one sensor)		11K76	OX	OX	OX	OX	OX
Smoke Detector - Supply and Return (Power board and two sensors)		11K80	OX	OX	OX	OX	OX

NOTE - Catalog numbers shown are for ordering field installed accessories.
OX = Configure To Order (Factory Installed) or Field Installed.
O = Configure To Order (Factory Installed).
X = Field Installed.

OPTIONS / ACCESSORIES

Item Description	Catalog Number	Unit Model No					
		078	092	102	122	150	
INDOOR AIR QUALITY							
Air Filters							
Healthy Climate® High Efficiency Air Filters 20 x 25 x 2 in. (Order 4 per unit)	MERV 8	50W61	OX	OX	OX	OX	OX
	MERV 13	52W41	OX	OX	OX	OX	OX
	MERV 16	21U41	X	X	X	X	X
Replacement Media Filter With Metal Mesh Frame (includes non-pleated filter media)		Y3063	X	X	X	X	X
Indoor Air Quality (CO₂) Sensors							
Sensor - Wall-mount, off-white plastic cover with LCD display		77N39	X	X	X	X	X
Sensor - Wall-mount, off-white plastic cover, no display		23V86	X	X	X	X	X
Sensor - Black plastic case with LCD display, rated for plenum mounting		87N52	X	X	X	X	X
Sensor - Wall-mount, black plastic case, no display, rated for plenum mounting		87N54	X	X	X	X	X
CO ₂ Sensor Duct Mounting Kit - for downflow applications		85L43	X	X	X	X	X
Aspiration Box - for duct mounting non-plenum rated CO ₂ sensors (77N39)		90N43	X	X	X	X	X
Needlepoint Bipolar Ionization (NPBI)							
Needlepoint Bipolar Ionization (NPBI) Kit		22U15	X	X	X	X	X
UVC Germicidal Lamps							
¹ Healthy Climate® UVC Light Kit (110/230v-1ph)		21A93	X	X	X	X	X
Step-Down Transformers	460V primary, 230V secondary	10H20	X	X	X	X	X
	575V primary, 230V secondary	10H21	X	X	X	X	X
ELECTRICAL							
Voltage 60 Hz	208/230V - 3 phase	Factory	O	O	O	O	O
	460V - 3 phase	Factory	O	O	O	O	O
	575V - 3 phase	Factory	O	O	O	O	O
Disconnect Switch	80 amp	54W56	OX	OX	OX	OX	OX
² Short-Circuit Current Rating (SCCR) of 100kA (includes Phase/Voltage Detection)		Factory	O	O	O	O	O
GFI Service Outlets	15 amp non-powered, field-wired (208/230V, 460V only)	74M70	OX	OX	OX	OX	OX
	15 amp factory-wired and powered (208/230V, 460V)	Factory	O	O	O	O	O
	³ 20 amp non-powered, field-wired (208/230V, 460V, 575V)	67E01	X	X	X	X	X
	³ 20 amp non-powered, field-wired (575V only)	Factory	O	O	O	O	O
Weatherproof Cover for GFI		10C89	X	X	X	X	X

¹ Lamps operate on 110-230V single-phase power supply. Step-down transformer may be ordered separately for 460V and 575V units. Alternately, 110V power supply may be used to directly power the UVC ballast(s).

² Disconnect Switch not available with higher SCCR option. Short-Circuit Current Rating option not available on field installed electric heat.

³ Canada requires a minimum 20 amp circuit. Select 20 amp, non-powered, field wired GFI.

NOTE - Catalog numbers shown are for ordering field installed accessories.

OX = Configure To Order (Factory Installed) or Field Installed.

O = Configure To Order (Factory Installed).

X = Field Installed.

OPTIONS / ACCESSORIES

Item Description	Catalog Number	Unit Model No				
		078	092	102	122	150
ECONOMIZER						
High Performance Economizer (Approved for California Title 24 Building Standards / AMCA Class 1A Certified)						
High Performance Economizer (Downflow or Horizontal) Includes Economizer Dampers with Outdoor Air Hood and Barometric Relief Dampers with Exhaust Hood Downflow Applications - Use furnished Outdoor Air Hood and Barometric Relief Dampers with Exhaust Hood Horizontal Applications - Use furnished Outdoor Air Hood and Barometric Relief Dampers with Exhaust Hood - Order Horizontal Discharge Kit separately Horizontal Applications (reduced height) - Order Horizontal Low Profile Barometric Relief Dampers with Exhaust Hood and Horizontal Discharge Kit (51W25) separately	20U80	OX	OX	OX	OX	OX
Horizontal Low Profile Barometric Relief Dampers						
Horizontal Low Profile Barometric Relief Dampers (Exhaust hood furnished)	53K04	X	X	X	X	X
Economizer Controls						
Differential Enthalpy (Not for Title 24)	Order 2 21Z09	OX	OX	OX	OX	OX
Sensible Control	Sensor is Furnished Factory	O	O	O	O	O
Single Enthalpy (Not for Title 24)	21Z09	OX	OX	OX	OX	OX
Building Pressure Control	13J77	X	X	X	X	X
Outdoor Air CFM Control	13J76	X	X	X	X	X
Global Control	Sensor Field Provided Factory	O	O	O	O	O
OUTDOOR AIR						
Outdoor Air Dampers With Outdoor Air Hood						
Motorized	14G28	OX	OX	OX	OX	OX
Manual	14G29	X	X	X	X	X
POWER EXHAUST						
Standard Static	208/230V-3ph 53W44	OX	OX	OX	OX	OX
	460V-3ph 53W45	OX	OX	OX	OX	OX
	575V-3ph 53W46	OX	OX	OX	OX	OX
ROOF CURBS						
Hybrid Roof Curbs, Downflow						
8 in. height	11F54	X	X	X	X	X
14 in. height	11F55	X	X	X	X	X
18 in. height	11F56	X	X	X	X	X
24 in. height	11F57	X	X	X	X	X
Adjustable Pitch Curb						
14 in. height	54W50	X	X	X	X	X
CEILING DIFFUSERS						
Step-Down - Order one	RTD11-95S 13K61	X	X			
	RTD11-135S 13K62			X	X	X
Flush - Order one	FD11-95S 13K56	X	X			
	FD11-135S 13K57			X	X	X
Transitions (Supply and Return) - Order one	C1DIFF30B-1 12X65	X	X			
	C1DIFF31B-1 12X66			X	X	X

NOTE - Catalog numbers shown are for ordering field installed accessories.
OX = Configure To Order (Factory Installed) or Field Installed.
O = Configure To Order (Factory Installed).
X = Field Installed.

SPECIFICATIONS		6.5 TON 7.5 TON 8.5 TON		
General Data	Nominal Tonnage	6.5 Ton	7.5 Ton	8.5 Ton
	Efficiency Type	High	High	High
	Model Number	LDT078H4E	LDT092H4E	LDT102H4E
	Blower Type	DirectPlus™ ECM Direct Drive with MSAV®	DirectPlus™ ECM Direct Drive with MSAV®	DirectPlus™ ECM Direct Drive with MSAV®
Cooling Performance	Gross Cooling Capacity - Btuh	79,000	92,000	100,000
	¹ Net Cooling Capacity - Btuh	78,000	90,000	98,000
	AHRI Rated Air Flow - cfm	2400	2800	2800
	Total Unit Power - kW	6.4	7.6	8.3
	¹ EER (Btuh/Watt)	12.2	11.9	11.9
	¹ IEER (Btuh/Watt)	16.5	16.0	15.5
	Refrigerant Type	R410A	R410A	R410A
	Refrigerant Charge Furnished	Circuit 1 Circuit 2	12 lbs. 0 oz. 12 lbs. 8 oz.	11 lbs. 10 oz. 11 lbs. 10 oz.
Heating Performance	¹ Total High Heat Capacity - Btuh	73,000	84,000	94,000
	¹ AHRI Rated Air Flow - cfm	2600	3000	3400
	Total Unit Power - kW	6.1	7.0	7.9
	¹ C.O.P.	3.5	3.5	3.5
	¹ Total Low Heat Capacity - Btuh	40,000	46,000	53,000
	Total Unit Power (kW) ¹ C.O.P.	5.2 2.25	6.0 2.25	6.9 2.25
Gas Heating Options Available - See Page 22		Standard (2 stage), Medium (2 Stage)	Standard (2 stage), Medium (2 Stage), High (2 Stage)	
Compressor Type (number)		Two-Stage Scroll (1) Single-Stage Scroll (1)		
Outdoor Coil	Net face area (total) - sq. ft.	25.9	25.9	25.9
	Tube diameter - in.	3/8	3/8	3/8
	Number of rows	3	3	3
	Fins per inch	20	20	20
Outdoor Coil Fans	Motor - (No.) hp	(2) 1/3 ECM	(2) 1/3 ECM	(2) 1/3 ECM
	Motor rpm	530-950	530-950	650-1010
	Total Motor watts	140-620	140-620	220-700
	Diameter - (No.) in.	(2) 24	(2) 24	(2) 24
	Number of blades	3	3	3
	Total Air volume - cfm	3600-7000	3600-7000	4600-7500
Indoor Coil	Net face area (total) - sq. ft.	12.8	12.8	12.8
	Tube diameter - in.	3/8	3/8	3/8
	Number of rows	4	4	4
	Fins per inch	14	14	14
	Drain connection - Number and size Expansion device type	(1) 1 in. NPT coupling Balanced Port Thermostatic Expansion Valve (removable element head)		
Indoor Blower	Nominal motor output	3.75 hp (ECM)	3.75 hp (ECM)	3.75 hp (ECM)
	Blower wheel nominal diameter x width - in.	(1) 22 x 19	(1) 22 x 19	(1) 22 x 19
Filters	Type of filter	MERV 4, Disposable		
	Number and size - in.	(4) 20 x 25 x 2		
Electrical characteristics		208/230V, 460V or 575V - 60 hertz - 3 phase		

NOTE - Net capacity includes evaporator blower motor heat deduction. Gross capacity does not include evaporator blower motor heat deduction.

¹ AHRI Certified to AHRI Standard 340/360:

Cooling Ratings - 95°F outdoor air temperature and 80°F db/67°F wb entering indoor coil air.

High Temperature Heating Ratings - 47°F db/43°F wb outdoor air temperature and 70°F entering indoor coil air.

Low Temperature Heating Ratings - 17°F db/15°F wb outdoor air temperature and 70°F entering indoor coil air.

SPECIFICATIONS		10 TON 12.5 TON	
General Data	Nominal Tonnage	10 Ton	12.5 Ton
	Efficiency Type	High	High
	Model Number	LDT122H4E	LDT150H4E
	Blower Type	DirectPlus™ ECM Direct Drive with MSAV®	DirectPlus™ ECM Direct Drive with MSAV®
Cooling Performance	Gross Cooling Capacity - Btuh	121,000	141,000
	¹ Net Cooling Capacity - Btuh	118,000	136,000
	AHRI Rated Air Flow - cfm	3400	4200
	Total Unit Power - kW	9.9	12.6
	¹ EER (Btuh/Watt)	11.9	10.8
	¹ IEER (Btuh/Watt)	15.5	14.3
	Refrigerant Type	R410A	R410A
	Refrigerant Charge Furnished	Circuit 1 Circuit 2	21 lbs. 8 oz. 20 lbs. 8 oz.
Heating Performance	¹ Total High Heat Capacity - Btuh	114,000	128,000
	¹ AHRI Rated Air Flow - cfm	3600	4200
	Total Unit Power - kW	9.5	11
	¹ C.O.P.	3.45	3.35
	¹ Total Low Heat Capacity - Btuh	65,000	73,000
	Total Unit Power (kW)	8.5	10.2
	¹ C.O.P.	2.25	2.10
Gas Heating Options Available - See Page 22		Standard (2 stage), Medium (2 Stage), High (2 Stage)	
Compressor Type (number)		Two-Stage Scroll (1) Single-Stage Scroll (1)	
Outdoor Coil	Net face area (total) - sq. ft.	40.4	40.4
	Tube diameter - in.	3/8	3/8
	Number of rows	3	3
	Fins per inch	20	20
Outdoor Coil Fans	Motor - (No.) hp	(3) 1/3 ECM	(3) 1/3 ECM
	Motor rpm	530-950	530-950
	Total Motor watts	180-800	180-800
	Diameter - (No.) in.	(3) 24	(3) 24
	Number of blades	3	3
	Total Air volume - cfm	5500-10,600	5500-10,600
Indoor Coil	Net face area (total) - sq. ft.	12.8	12.8
	Tube diameter - in.	3/8	3/8
	Number of rows	4	4
	Fins per inch	14	14
	Drain connection - Number and size	(1) 1 in. NPT coupling	
	Expansion device type	Balanced Port Thermostatic Expansion Valve (removable element head)	
Indoor Blower	Nominal motor output	3.75 hp (ECM)	3.75 hp (ECM)
	Blower wheel nominal diameter x width - in.	(1) 22 x 19	(1) 22 x 19
Filters	Type of filter	MERV 4, Disposable	
	Number and size - in.	(4) 20 x 25 x 2	
Electrical characteristics		208/230V, 460V or 575V - 60 hertz - 3 phase	

NOTE - Net capacity includes evaporator blower motor heat deduction. Gross capacity does not include evaporator blower motor heat deduction.

¹ AHRI Certified to AHRI Standard 340/360:

Cooling Ratings - 95°F outdoor air temperature and 80°F db/67°F wb entering indoor coil air.

High Temperature Heating Ratings - 47°F db/43°F wb outdoor air temperature and 70°F entering indoor coil air.

Low Temperature Heating Ratings - 17°F db/15°F wb outdoor air temperature and 70°F entering indoor coil air.

SPECIFICATIONS**GAS HEAT**

			Standard	Medium	High
		Heat Input Type			
		Number of Gas Heat Stages	2	2	2
Gas Heating Performance	Input - Btuh	First Stage	85,000	117,000	156,000
		Second Stage	130,000	180,000	240,000
	Output - Btuh	Second Stage	105,000	146,000	194,000
		Temperature Rise Range - °F	15 - 45	30 - 60	40 - 70
Minimum Air Volume - cfm			2150	2250	2600
Thermal Efficiency			81%	81%	81%
Gas Supply Connections			3/4 in. NPT	3/4 in. NPT	3/4 in. NPT.
Recommended Gas Supply Pressure - Nat. / LPG			7 in. w.g. / 11 in. w.g.		
Gas Supply Pressure Range	Min./Max. (Natural)		4.7 - 10.5 in. w.g.		
	Min./Max. (LPG)		10.8 - 13.5 in. w.g.		

HIGH ALTITUDE DERATE

NOTE - Units may be installed at altitudes up to 2000 feet above sea level without any modifications.

At altitudes above 2000 feet units must be derated to match gas manifold pressures shown in table below.

At altitudes above 4500 feet unit must be derated 4% for each 1000 feet above sea level.

NOTE - This is the only permissible derate for these units.

Refer to the Installation Instructions for more detailed information.

Heat Input Type	Altitude Feet	Gas Manifold Pressure in. w.g.		Input Rate (Btuh)
		Natural Gas	LPG/ Propane	
Standard (2 stage)	2001 - 4500	1.6 / 3.1	4.4 / 8.9	84,500 / 120,000
Medium (2 stage)	2001 - 4500	1.6 / 3.1	4.4 / 8.9	117,000 / 166,000
High (2 stage)	2001 - 4500	1.6 / 3.1	4.4 / 8.9	156,000 / 221,000

COOLING/HEATING RATINGS

NOTE – For Temperatures and Capacities not shown in tables, see bulletin – Cooling Unit Rating Table Correction Factor Data in Miscellaneous Engineering Data section.

6.5 TON - COOLING LDT078H4E (1 COMPRESSOR - PART LOAD)

Entering Wet Bulb Temperature	Total Air Volume	Outdoor Air Temperature Entering Outdoor Coil																			
		65°F					75°F					85°F					95°F				
		Total Cool Cap.	Comp. Motor Input	Sensible To Total Ratio (S/T)			Total Cool Cap.	Comp. Motor Input	Sensible To Total Ratio (S/T)			Total Cool Cap.	Comp. Motor Input	Sensible To Total Ratio (S/T)			Total Cool Cap.	Comp. Motor Input	Sensible To Total Ratio (S/T)		
				Dry Bulb					Dry Bulb					Dry Bulb					Dry Bulb		
		cfm	kBtuh	kW	75°F	80°F	85°F	kBtuh	kW	75°F	80°F	85°F	kBtuh	kW	75°F	80°F	85°F	kBtuh	kW	75°F	80°F
63°F	1440	32.4	1.37	0.65	0.77	0.88	30.5	1.65	0.65	0.78	0.9	28.2	1.95	0.65	0.79	0.92	25.7	2.28	0.66	0.8	0.95
	1800	34.8	1.35	0.69	0.83	0.96	32.8	1.63	0.69	0.84	0.98	30.4	1.93	0.7	0.86	1	27.8	2.25	0.71	0.89	1
	2160	36.6	1.34	0.74	0.88	1	34.5	1.62	0.74	0.91	1	32	1.92	0.76	0.93	1	29.3	2.24	0.77	0.97	1
67°F	1440	35	1.35	0.52	0.63	0.73	33.1	1.63	0.51	0.63	0.74	30.8	1.92	0.51	0.63	0.75	28.1	2.25	0.5	0.63	0.76
	1800	37.6	1.34	0.55	0.67	0.79	35.5	1.61	0.54	0.67	0.8	32.9	1.91	0.54	0.67	0.82	30.2	2.23	0.54	0.69	0.84
	2160	39.5	1.32	0.57	0.71	0.83	37.2	1.61	0.57	0.72	0.87	34.7	1.91	0.57	0.73	0.89	31.8	2.23	0.57	0.75	0.92
71°F	1440	37.8	1.34	0.41	0.51	0.6	35.7	1.61	0.4	0.5	0.6	33.4	1.91	0.38	0.49	0.6	30.7	2.23	0.37	0.49	0.61
	1800	40.4	1.32	0.42	0.53	0.64	38.2	1.61	0.4	0.53	0.65	35.7	1.9	0.4	0.53	0.64	32.9	2.23	0.39	0.53	0.66
	2160	42.3	1.32	0.43	0.56	0.68	40	1.6	0.42	0.56	0.69	37.4	1.9	0.42	0.56	0.71	34.4	2.22	0.4	0.56	0.72

6.5 TON - COOLING LDT078H4E (2 COMPRESSORS - PART LOAD / FULL LOAD)

Entering Wet Bulb Temperature	Total Air Volume	Outdoor Air Temperature Entering Outdoor Coil																			
		85°F					95°F					105°F					115°F				
		Total Cool Cap.	Comp. Motor Input	Sensible To Total Ratio (S/T)			Total Cool Cap.	Comp. Motor Input	Sensible To Total Ratio (S/T)			Total Cool Cap.	Comp. Motor Input	Sensible To Total Ratio (S/T)			Total Cool Cap.	Comp. Motor Input	Sensible To Total Ratio (S/T)		
				Dry Bulb					Dry Bulb					Dry Bulb					Dry Bulb		
		cfm	kBtuh	kW	75°F	80°F	85°F	kBtuh	kW	75°F	80°F	85°F	kBtuh	kW	75°F	80°F	85°F	kBtuh	kW	75°F	80°F
63°F	1680	62.1	3.79	0.67	0.82	0.96	57.1	4.39	0.68	0.83	0.98	51.8	5.05	0.69	0.86	1	46	5.8	0.71	0.9	1
	2100	66.3	3.77	0.73	0.9	1	61.3	4.37	0.74	0.92	1	55.6	5.04	0.76	0.96	1	49.8	5.78	0.79	0.98	1
	2520	69.7	3.77	0.78	0.97	1	64.6	4.36	0.8	0.99	1	59.3	5.02	0.83	1	1	53.8	5.76	0.87	1	1
67°F	1680	67.3	3.77	0.52	0.65	0.78	62.2	4.37	0.52	0.66	0.79	56.8	5.03	0.52	0.67	0.82	50.7	5.77	0.52	0.68	0.85
	2100	71.6	3.76	0.56	0.7	0.86	66.4	4.36	0.56	0.72	0.88	60.5	5.02	0.55	0.73	0.91	54.1	5.77	0.56	0.76	0.96
	2520	75	3.75	0.59	0.76	0.93	69.3	4.36	0.59	0.78	0.96	63.3	5.02	0.6	0.8	0.98	56.6	5.75	0.61	0.84	1
71°F	1680	72.6	3.75	0.39	0.51	0.63	67.4	4.36	0.38	0.51	0.63	61.9	5.02	0.37	0.51	0.64	55.7	5.75	0.35	0.51	0.66
	2100	77.2	3.75	0.41	0.55	0.68	71.7	4.36	0.4	0.55	0.69	65.8	5.01	0.38	0.55	0.71	59.2	5.76	0.38	0.56	0.73
	2520	80.5	3.75	0.42	0.58	0.73	74.7	4.36	0.41	0.59	0.75	68.5	5.02	0.41	0.59	0.77	61.8	5.76	0.4	0.61	0.81

6.5 TON - COOLING LDT078H4E (2 COMPRESSORS - FULL LOAD)

Entering Wet Bulb Temperature	Total Air Volume	Outdoor Air Temperature Entering Outdoor Coil																			
		85°F					95°F					105°F					115°F				
		Total Cool Cap.	Comp. Motor Input	Sensible To Total Ratio (S/T)			Total Cool Cap.	Comp. Motor Input	Sensible To Total Ratio (S/T)			Total Cool Cap.	Comp. Motor Input	Sensible To Total Ratio (S/T)			Total Cool Cap.	Comp. Motor Input	Sensible To Total Ratio (S/T)		
				Dry Bulb					Dry Bulb					Dry Bulb					Dry Bulb		
		cfm	kBtuh	kW	75°F	80°F	85°F	kBtuh	kW	75°F	80°F	85°F	kBtuh	kW	75°F	80°F	85°F	kBtuh	kW	75°F	80°F
63°F	2080	76.9	4.52	0.68	0.82	0.95	71.8	5.12	0.69	0.84	0.96	66.2	5.8	0.7	0.86	0.98	60.1	6.56	0.71	0.89	1
	2600	81.9	4.54	0.73	0.9	1	76.4	5.15	0.75	0.92	1	70.7	5.81	0.76	0.94	1	64.7	6.58	0.79	0.96	1
	3120	86	4.56	0.79	0.96	1	80.7	5.16	0.81	0.97	1	74.9	5.84	0.83	0.99	1	68.5	6.6	0.86	1	1
67°F	2080	82.9	4.54	0.53	0.66	0.79	77.5	5.15	0.53	0.67	0.8	71.7	5.82	0.53	0.67	0.82	65.5	6.58	0.53	0.69	0.85
	2600	87.9	4.57	0.57	0.71	0.86	82.1	5.17	0.57	0.72	0.89	75.9	5.84	0.58	0.74	0.91	69.3	6.6	0.57	0.76	0.94
	3120	91.4	4.59	0.6	0.77	0.93	85.4	5.2	0.6	0.78	0.95	79	5.87	0.61	0.81	0.97	72.1	6.63	0.62	0.84	0.99
71°F	2080	88.9	4.57	0.4	0.52	0.64	83.4	5.18	0.39	0.52	0.64	77.4	5.85	0.38	0.52	0.65	70.9	6.62	0.37	0.52	0.66
	2600	94	4.6	0.41	0.55	0.69	88.1	5.21	0.41	0.56	0.7	81.7	5.88	0.4	0.56	0.72	74.9	6.64	0.39	0.57	0.74
	3120	97.8	4.62	0.43	0.59	0.74	91.4	5.23	0.42	0.59	0.76	84.9	5.9	0.42	0.6	0.78	77.6	6.66	0.41	0.61	0.81

6.5 TON - HEATING LDT078H4E

Indoor Coil Air Volume 70°F Dry Bulb cfm	Air Temperature Entering Outdoor Coil									
	65°F		45°F		25°F		5°F		-15°F	
	Total Heating Capacity	Comp. Motor Input	Total Heating Capacity	Comp. Motor Input	Total Heating Capacity	Comp. Motor Input	Total Heating Capacity	Comp. Motor Input	Total Heating Capacity	Comp. Motor Input
	kBtuh	kW	kBtuh	kW	kBtuh	kW	kBtuh	kW	kBtuh	kW
2080	97.0	5.79	70.4	5.13	49.8	4.65	33.2	4.29	14.7	4.06
2600	100.1	5.27	72.2	4.77	50.9	4.40	33.9	4.14	15.7	3.96
3120	102.4	4.94	73.4	4.54	51.8	4.24	34.6	4.06	16.1	3.93

COOLING/HEATING RATINGS

NOTE – For Temperatures and Capacities not shown in tables, see bulletin – Cooling Unit Rating Table Correction Factor Data in Miscellaneous Engineering Data section.

7.5 TON - COOLING LDT092H4E (1 COMPRESSOR - PART LOAD)

Entering Wet Bulb Temperature	Total Air Volume	Outdoor Air Temperature Entering Outdoor Coil																			
		65°F					75°F					85°F					95°F				
		Total Cool Cap.	Comp. Motor Input	Sensible To Total Ratio (S/T)			Total Cool Cap.	Comp. Motor Input	Sensible To Total Ratio (S/T)			Total Cool Cap.	Comp. Motor Input	Sensible To Total Ratio (S/T)			Total Cool Cap.	Comp. Motor Input	Sensible To Total Ratio (S/T)		
				Dry Bulb					Dry Bulb					Dry Bulb					Dry Bulb		
cfm	kBtuh	kW	75°F	80°F	85°F	kBtuh	kW	75°F	80°F	85°F	kBtuh	kW	75°F	80°F	85°F	kBtuh	kW	75°F	80°F	85°F	
63°F	1600	34.1	1.38	0.67	0.8	0.92	31.9	1.65	0.67	0.81	0.94	29.5	1.96	0.68	0.82	0.96	26.7	2.29	0.69	0.84	0.99
	2000	36.4	1.36	0.72	0.86	0.99	34.3	1.64	0.72	0.88	1	31.7	1.94	0.74	0.9	1	28.8	2.27	0.75	0.94	1
	2400	38.3	1.35	0.77	0.93	1	36	1.63	0.78	0.95	1	33.4	1.93	0.79	0.97	1	30.5	2.26	0.82	1	1
67°F	1600	36.8	1.36	0.54	0.65	0.76	34.7	1.64	0.53	0.65	0.77	32.2	1.94	0.52	0.65	0.78	29.3	2.27	0.52	0.66	0.8
	2000	39.3	1.34	0.56	0.7	0.83	37	1.62	0.56	0.7	0.84	34.3	1.93	0.56	0.71	0.86	31.4	2.25	0.56	0.73	0.89
	2400	41.2	1.34	0.59	0.74	0.89	38.8	1.62	0.59	0.75	0.91	36	1.92	0.59	0.77	0.94	32.9	2.25	0.6	0.79	0.97
71°F	1600	39.7	1.34	0.41	0.52	0.62	37.5	1.63	0.4	0.52	0.63	34.9	1.92	0.39	0.51	0.63	32	2.25	0.38	0.51	0.63
	2000	42.3	1.33	0.42	0.55	0.67	39.9	1.61	0.42	0.55	0.68	37.2	1.91	0.41	0.55	0.69	34.2	2.24	0.39	0.55	0.7
	2400	44.1	1.33	0.44	0.58	0.72	41.7	1.61	0.43	0.58	0.73	38.8	1.92	0.42	0.58	0.74	35.6	2.24	0.4	0.59	0.76

7.5 TON - COOLING LDT092H4E (2 COMPRESSORS - PART LOAD / FULL LOAD)

Entering Wet Bulb Temperature	Total Air Volume	Outdoor Air Temperature Entering Outdoor Coil																			
		85°F					95°F					105°F					115°F				
		Total Cool Cap.	Comp. Motor Input	Sensible To Total Ratio (S/T)			Total Cool Cap.	Comp. Motor Input	Sensible To Total Ratio (S/T)			Total Cool Cap.	Comp. Motor Input	Sensible To Total Ratio (S/T)			Total Cool Cap.	Comp. Motor Input	Sensible To Total Ratio (S/T)		
				Dry Bulb					Dry Bulb					Dry Bulb					Dry Bulb		
cfm	kBtuh	kW	75°F	80°F	85°F	kBtuh	kW	75°F	80°F	85°F	kBtuh	kW	75°F	80°F	85°F	kBtuh	kW	75°F	80°F	85°F	
63°F	1920	72.7	4.68	0.68	0.82	0.93	66.9	5.38	0.68	0.83	0.95	60.7	6.18	0.7	0.86	0.96	54.2	7.07	0.71	0.89	0.98
	2400	77.7	4.68	0.73	0.89	0.98	71.8	5.38	0.74	0.91	0.99	65.7	6.17	0.76	0.92	1	59.2	7.07	0.79	0.94	1
	2880	82.1	4.68	0.78	0.94	1	76.1	5.38	0.8	0.95	1	69.7	6.17	0.83	0.97	1	62.9	7.06	0.86	0.99	1
67°F	1920	78.6	4.67	0.53	0.66	0.78	72.7	5.38	0.52	0.66	0.79	66.4	6.17	0.52	0.67	0.82	59.5	7.07	0.52	0.68	0.85
	2400	83.7	4.69	0.56	0.71	0.85	77.5	5.39	0.56	0.72	0.87	70.7	6.17	0.56	0.74	0.9	63.5	7.07	0.57	0.76	0.92
	2880	87.5	4.69	0.59	0.76	0.92	80.8	5.38	0.6	0.77	0.93	73.9	6.18	0.61	0.8	0.94	66.4	7.08	0.62	0.84	0.97
71°F	1920	84.8	4.68	0.4	0.52	0.63	78.8	5.39	0.38	0.51	0.64	72.2	6.17	0.37	0.51	0.65	65	7.05	0.35	0.51	0.66
	2400	90.1	4.7	0.41	0.55	0.68	83.6	5.4	0.4	0.55	0.69	76.6	6.18	0.39	0.55	0.71	69.2	7.07	0.38	0.56	0.74
	2880	93.8	4.71	0.43	0.58	0.74	87.1	5.41	0.42	0.59	0.76	79.9	6.19	0.42	0.6	0.78	72.1	7.08	0.4	0.61	0.81

7.5 TON - COOLING LDT092H4E (2 COMPRESSORS - FULL LOAD)

Entering Wet Bulb Temperature	Total Air Volume	Outdoor Air Temperature Entering Outdoor Coil																			
		85°F					95°F					105°F					115°F				
		Total Cool Cap.	Comp. Motor Input	Sensible To Total Ratio (S/T)			Total Cool Cap.	Comp. Motor Input	Sensible To Total Ratio (S/T)			Total Cool Cap.	Comp. Motor Input	Sensible To Total Ratio (S/T)			Total Cool Cap.	Comp. Motor Input	Sensible To Total Ratio (S/T)		
				Dry Bulb					Dry Bulb					Dry Bulb					Dry Bulb		
cfm	kBtuh	kW	75°F	80°F	85°F	kBtuh	kW	75°F	80°F	85°F	kBtuh	kW	75°F	80°F	85°F	kBtuh	kW	75°F	80°F	85°F	
63°F	2400	89.7	5.43	0.69	0.83	0.96	83.6	6.14	0.69	0.85	0.99	77.1	6.94	0.71	0.87	1	70	7.86	0.72	0.9	1
	3000	95.4	5.47	0.74	0.9	1	88.8	6.17	0.76	0.93	1	81.8	6.97	0.77	0.96	1	74.6	7.88	0.8	0.99	1
	3600	99.6	5.5	0.8	0.98	1	92.7	6.19	0.82	1	1	86.2	6.99	0.84	1	1	79.6	7.92	0.87	1	1
67°F	2400	96.6	5.48	0.54	0.67	0.79	90.3	6.18	0.53	0.67	0.81	83.5	6.98	0.54	0.68	0.83	76.1	7.89	0.53	0.7	0.86
	3000	102.1	5.51	0.57	0.72	0.87	95.2	6.21	0.58	0.73	0.89	88.1	7.01	0.58	0.75	0.92	80.3	7.91	0.58	0.77	0.96
	3600	106.1	5.54	0.61	0.78	0.94	99	6.24	0.61	0.79	0.97	91.4	7.03	0.61	0.82	0.99	83.2	7.93	0.63	0.85	1
71°F	2400	103.5	5.52	0.4	0.53	0.64	96.8	6.22	0.39	0.52	0.65	89.8	7.01	0.39	0.53	0.66	82.1	7.92	0.37	0.52	0.68
	3000	109	5.56	0.42	0.56	0.7	102.1	6.26	0.41	0.56	0.71	94.7	7.05	0.41	0.57	0.73	86.7	7.95	0.4	0.58	0.75
	3600	113.3	5.59	0.44	0.6	0.75	106	6.28	0.43	0.6	0.77	97.9	7.06	0.42	0.61	0.79	89.9	7.97	0.42	0.63	0.82

7.5 TON - HEATING LDT092H4E

Indoor Coil Air Volume 70°F Dry Bulb cfm	Air Temperature Entering Outdoor Coil									
	65°F		45°F		25°F		5°F		-15°F	
	Total Heating Capacity	Comp. Motor Input	Total Heating Capacity	Comp. Motor Input	Total Heating Capacity	Comp. Motor Input	Total Heating Capacity	Comp. Motor Input	Total Heating Capacity	Comp. Motor Input
	kBtuh	kW	kBtuh	kW	kBtuh	kW	kBtuh	kW	kBtuh	kW
2400	111.9	6.67	81.1	5.92	57.4	5.33	38.4	4.92	19.2	4.84
3000	115.3	6.09	83.1	5.51	58.7	5.06	39.3	4.77	19.8	4.78
3600	118.0	5.73	84.7	5.25	59.8	4.89	40.2	4.69	20.4	4.74

COOLING/HEATING RATINGS

NOTE – For Temperatures and Capacities not shown in tables, see bulletin – Cooling Unit Rating Table Correction Factor Data in Miscellaneous Engineering Data section.

8.5 TON - COOLING LDT102H4E (1 COMPRESSOR - PART LOAD)

Entering Wet Bulb Temperature	Total Air Volume	Outdoor Air Temperature Entering Outdoor Coil																							
		65°F						75°F						85°F						95°F					
		Total Cool Cap.	Comp. Motor Input	Sensible To Total Ratio (S/T)			Total Cool Cap.	Comp. Motor Input	Sensible To Total Ratio (S/T)			Total Cool Cap.	Comp. Motor Input	Sensible To Total Ratio (S/T)			Total Cool Cap.	Comp. Motor Input	Sensible To Total Ratio (S/T)						
				Dry Bulb					Dry Bulb					Dry Bulb					Dry Bulb						
		cfm	kBtuh	kW	75°F	80°F	85°F	kBtuh	kW	75°F	80°F	85°F	kBtuh	kW	75°F	80°F	85°F	kBtuh	kW	75°F	80°F	85°F			
63°F	1760	35	1.36	0.68	0.82	0.95	32.8	1.64	0.69	0.83	0.97	30.1	1.94	0.69	0.85	1	27.2	2.27	0.69	0.87	1				
	2200	37.3	1.33	0.74	0.89	1	35	1.62	0.74	0.91	1	32.3	1.92	0.75	0.94	1	29.2	2.25	0.77	0.97	1				
	2640	39.2	1.33	0.78	0.96	1	36.8	1.61	0.79	0.98	1	34.1	1.91	0.82	1	1	31.3	2.24	0.84	1	1				
67°F	1760	37.8	1.33	0.54	0.66	0.78	35.6	1.62	0.53	0.66	0.79	32.9	1.92	0.53	0.66	0.81	29.9	2.25	0.52	0.68	0.83				
	2200	40.2	1.32	0.57	0.71	0.83	37.9	1.61	0.57	0.72	0.87	35	1.91	0.57	0.73	0.89	31.9	2.24	0.57	0.74	0.93				
	2640	42	1.31	0.6	0.76	0.92	39.5	1.6	0.6	0.77	0.94	36.6	1.9	0.61	0.79	0.97	33.3	2.23	0.61	0.81	1				
71°F	1760	40.8	1.32	0.41	0.53	0.64	38.5	1.6	0.4	0.52	0.64	35.7	1.9	0.39	0.51	0.64	32.7	2.24	0.37	0.52	0.65				
	2200	43.2	1.31	0.42	0.56	0.69	40.8	1.59	0.42	0.56	0.7	37.9	1.9	0.41	0.56	0.71	34.7	2.23	0.39	0.56	0.72				
	2640	45.1	1.31	0.44	0.6	0.74	42.5	1.59	0.43	0.59	0.75	39.6	1.89	0.43	0.6	0.76	36.2	2.23	0.42	0.61	0.79				

8.5 TON - COOLING LDT102H4E (2 COMPRESSORS - PART LOAD / FULL LOAD)

Entering Wet Bulb Temperature	Total Air Volume	Outdoor Air Temperature Entering Outdoor Coil																							
		85°F						95°F						105°F						115°F					
		Total Cool Cap.	Comp. Motor Input	Sensible To Total Ratio (S/T)			Total Cool Cap.	Comp. Motor Input	Sensible To Total Ratio (S/T)			Total Cool Cap.	Comp. Motor Input	Sensible To Total Ratio (S/T)			Total Cool Cap.	Comp. Motor Input	Sensible To Total Ratio (S/T)						
				Dry Bulb					Dry Bulb					Dry Bulb					Dry Bulb						
		cfm	kBtuh	kW	75°F	80°F	85°F	kBtuh	kW	75°F	80°F	85°F	kBtuh	kW	75°F	80°F	85°F	kBtuh	kW	75°F	80°F	85°F			
63°F	2160	81	5.32	0.68	0.82	0.92	74.9	6.1	0.68	0.83	0.93	68.2	6.97	0.69	0.86	0.94	61.5	7.96	0.71	0.87	0.96				
	2700	86.9	5.34	0.73	0.88	0.97	80.6	6.11	0.74	0.89	0.98	73.9	6.98	0.76	0.9	1	66.6	7.97	0.79	0.92	1				
	3240	91.9	5.36	0.78	0.92	1	85.2	6.12	0.8	0.93	1	78.2	6.99	0.82	0.95	1	70.8	7.99	0.84	0.97	1				
67°F	2160	87.7	5.34	0.53	0.66	0.78	81.1	6.11	0.52	0.66	0.8	74.1	6.98	0.51	0.67	0.82	66.6	7.99	0.52	0.68	0.84				
	2700	93.2	5.36	0.56	0.7	0.85	86.2	6.13	0.56	0.72	0.87	78.9	7	0.57	0.73	0.88	70.9	8.01	0.57	0.76	0.9				
	3240	97.4	5.39	0.59	0.76	0.9	90.1	6.15	0.6	0.78	0.91	82.2	7.02	0.6	0.8	0.93	74	8.02	0.61	0.83	0.95				
71°F	2160	94.4	5.36	0.4	0.51	0.63	87.7	6.14	0.38	0.51	0.64	80.4	7.01	0.37	0.51	0.64	72.6	8	0.35	0.51	0.66				
	2700	100	5.39	0.41	0.55	0.68	92.8	6.16	0.4	0.55	0.69	85.2	7.03	0.39	0.56	0.71	77	8.02	0.38	0.56	0.73				
	3240	104.2	5.42	0.42	0.58	0.73	96.7	6.19	0.42	0.59	0.75	88.7	7.06	0.41	0.6	0.78	80	8.05	0.4	0.61	0.81				

8.5 TON - COOLING LDT102H4E (2 COMPRESSORS - FULL LOAD)

Entering Wet Bulb Temperature	Total Air Volume	Outdoor Air Temperature Entering Outdoor Coil																							
		85°F						95°F						105°F						115°F					
		Total Cool Cap.	Comp. Motor Input	Sensible To Total Ratio (S/T)			Total Cool Cap.	Comp. Motor Input	Sensible To Total Ratio (S/T)			Total Cool Cap.	Comp. Motor Input	Sensible To Total Ratio (S/T)			Total Cool Cap.	Comp. Motor Input	Sensible To Total Ratio (S/T)						
				Dry Bulb					Dry Bulb					Dry Bulb					Dry Bulb						
		cfm	kBtuh	kW	75°F	80°F	85°F	kBtuh	kW	75°F	80°F	85°F	kBtuh	kW	75°F	80°F	85°F	kBtuh	kW	75°F	80°F	85°F			
63°F	2720	100.3	6	0.69	0.83	0.97	93.3	6.77	0.7	0.85	0.98	86.1	7.63	0.71	0.88	0.99	78.3	8.63	0.72	0.91	1				
	3400	106.3	6.05	0.74	0.91	1	99.1	6.8	0.76	0.94	1	91.4	7.67	0.77	0.96	1	83.8	8.67	0.8	0.98	1				
	4080	111.1	6.08	0.8	0.97	1	103.9	6.84	0.82	0.99	1	96.5	7.71	0.84	1	1	88.8	8.71	0.88	1	1				
67°F	2720	107.7	6.05	0.53	0.67	0.8	100.6	6.81	0.53	0.68	0.81	92.9	7.68	0.53	0.68	0.84	85	8.68	0.54	0.7	0.87				
	3400	113.7	6.1	0.57	0.72	0.88	106.2	6.86	0.58	0.74	0.9	97.9	7.72	0.58	0.75	0.93	89.5	8.71	0.59	0.78	0.96				
	4080	117.8	6.13	0.6	0.78	0.95	110	6.89	0.61	0.8	0.97	101.6	7.75	0.62	0.82	0.98	92.8	8.74	0.63	0.86	1				
71°F	2720	115.1	6.11	0.4	0.52	0.64	107.8	6.86	0.39	0.52	0.65	99.9	7.73	0.38	0.52	0.66	91.7	8.74	0.37	0.53	0.68				
	3400	121.5	6.15	0.42	0.56	0.7	113.7	6.91	0.41	0.57	0.72	105.1	7.77	0.4	0.57	0.73	96.4	8.77	0.4	0.58	0.75				
	4080	125.8	6.18	0.43	0.6	0.75	117.7	6.94	0.43	0.61	0.78	109	7.81	0.42	0.62	0.8	99.7	8.8	0.42	0.62	0.83				

8.5 TON - HEATING LDT102H4E

Indoor Coil Air Volume 70°F Dry Bulb cfm	Air Temperature Entering Outdoor Coil									
	65°F		45°F		25°F		5°F		-15°F	
	Total Heating Capacity	Comp. Motor Input	Total Heating Capacity	Comp. Motor Input	Total Heating Capacity	Comp. Motor Input	Total Heating Capacity	Comp. Motor Input	Total Heating Capacity	Comp. Motor Input
	kBtuh	kW	kBtuh	kW	kBtuh	kW	kBtuh	kW	kBtuh	kW
2720	123.0	7.24	89.4	6.43	63.3	5.79	42.6	5.35	22.0	5.11
3400	126.6	6.63	91.6	6.00	64.7	5.52	43.6	5.19	22.7	5.06
4080	129.7	6.25	93.4	5.74	66.0	5.35	44.7	5.11	23.4	5.02

COOLING/HEATING RATINGS

NOTE – For Temperatures and Capacities not shown in tables, see bulletin – Cooling Unit Rating Table Correction Factor Data in Miscellaneous Engineering Data section.

10 TON - COOLING LDT122H4E (1 COMPRESSOR - PART LOAD)

Entering Wet Bulb Temperature	Total Air Volume	Outdoor Air Temperature Entering Outdoor Coil																			
		65°F					75°F					85°F					95°F				
		Total Cool Cap.	Comp. Motor Input	Sensible To Total Ratio (S/T)			Total Cool Cap.	Comp. Motor Input	Sensible To Total Ratio (S/T)			Total Cool Cap.	Comp. Motor Input	Sensible To Total Ratio (S/T)			Total Cool Cap.	Comp. Motor Input	Sensible To Total Ratio (S/T)		
				Dry Bulb					Dry Bulb					Dry Bulb					Dry Bulb		
cfm	kBtuh	kW	75°F	80°F	85°F	kBtuh	kW	75°F	80°F	85°F	kBtuh	kW	75°F	80°F	85°F	kBtuh	kW	75°F	80°F	85°F	
63°F	2080	41.7	1.87	0.68	0.8	0.93	38.8	2.15	0.67	0.81	0.95	35.7	2.48	0.67	0.82	0.97	32.3	2.87	0.67	0.84	0.99
	2600	44.8	1.84	0.72	0.87	1	41.8	2.12	0.72	0.89	1	38.5	2.43	0.73	0.9	1	35	2.82	0.74	0.93	1
	3120	47.2	1.81	0.77	0.93	1	44.1	2.09	0.78	0.95	1	40.7	2.4	0.79	0.97	1	37.1	2.79	0.81	1	1
67°F	2080	45.4	1.83	0.53	0.65	0.77	42.4	2.1	0.52	0.65	0.77	39.2	2.43	0.51	0.65	0.78	35.7	2.82	0.5	0.65	0.79
	2600	48.6	1.8	0.57	0.7	0.83	45.4	2.07	0.56	0.7	0.85	42	2.4	0.55	0.7	0.86	38.4	2.77	0.54	0.72	0.89
	3120	51	1.77	0.6	0.75	0.9	47.7	2.05	0.59	0.76	0.92	44.1	2.36	0.59	0.77	0.94	40.3	2.74	0.58	0.78	0.96
71°F	2080	49.1	1.78	0.41	0.52	0.63	46.1	2.06	0.4	0.51	0.62	42.8	2.39	0.37	0.5	0.63	39.2	2.77	0.35	0.49	0.62
	2600	52.5	1.75	0.43	0.55	0.68	49.2	2.03	0.41	0.55	0.68	45.8	2.34	0.39	0.54	0.68	42.1	2.71	0.38	0.54	0.69
	3120	55	1.72	0.44	0.58	0.72	51.6	2	0.43	0.58	0.73	47.9	2.32	0.42	0.58	0.74	43.9	2.67	0.4	0.58	0.75

10 TON - COOLING LDT122H4E (2 COMPRESSORS - PART LOAD / FULL LOAD)

Entering Wet Bulb Temperature	Total Air Volume	Outdoor Air Temperature Entering Outdoor Coil																			
		85°F					95°F					105°F					115°F				
		Total Cool Cap.	Comp. Motor Input	Sensible To Total Ratio (S/T)			Total Cool Cap.	Comp. Motor Input	Sensible To Total Ratio (S/T)			Total Cool Cap.	Comp. Motor Input	Sensible To Total Ratio (S/T)			Total Cool Cap.	Comp. Motor Input	Sensible To Total Ratio (S/T)		
				Dry Bulb					Dry Bulb					Dry Bulb					Dry Bulb		
cfm	kBtuh	kW	75°F	80°F	85°F	kBtuh	kW	75°F	80°F	85°F	kBtuh	kW	75°F	80°F	85°F	kBtuh	kW	75°F	80°F	85°F	
63°F	2560	98.6	6.57	0.67	0.81	0.92	90.8	7.51	0.67	0.82	0.93	82.4	8.61	0.68	0.84	0.94	73.5	9.88	0.68	0.86	0.96
	3200	105.8	6.54	0.72	0.87	0.96	97.8	7.5	0.73	0.89	0.97	89.5	8.57	0.74	0.9	0.99	80.5	9.82	0.76	0.91	1
	3840	112.2	6.53	0.77	0.92	1	104	7.47	0.78	0.93	1	95.3	8.54	0.8	0.94	1	85.7	9.78	0.83	0.96	1
67°F	2560	107	6.55	0.52	0.64	0.77	98.9	7.49	0.51	0.65	0.78	90.3	8.56	0.5	0.65	0.8	81	9.81	0.49	0.66	0.82
	3200	114.4	6.55	0.55	0.7	0.84	105.6	7.47	0.55	0.7	0.86	96.6	8.54	0.55	0.72	0.88	86.7	9.8	0.54	0.73	0.89
	3840	119.9	6.55	0.58	0.75	0.89	110.7	7.47	0.58	0.76	0.91	101.2	8.56	0.58	0.78	0.92	91	9.8	0.59	0.81	0.94
71°F	2560	115.8	6.52	0.39	0.51	0.62	107.5	7.46	0.37	0.5	0.63	98.6	8.54	0.35	0.5	0.63	88.9	9.8	0.33	0.49	0.64
	3200	123.3	6.54	0.4	0.54	0.67	114.3	7.46	0.39	0.54	0.68	104.9	8.52	0.38	0.54	0.69	94.7	9.77	0.36	0.54	0.71
	3840	128.8	6.54	0.42	0.58	0.73	119.4	7.44	0.41	0.58	0.74	109.6	8.54	0.4	0.58	0.76	98.9	9.79	0.38	0.58	0.78

10 TON - COOLING LDT122H4E (2 COMPRESSORS - FULL LOAD)

Entering Wet Bulb Temperature	Total Air Volume	Outdoor Air Temperature Entering Outdoor Coil																			
		85°F					95°F					105°F					115°F				
		Total Cool Cap.	Comp. Motor Input	Sensible To Total Ratio (S/T)			Total Cool Cap.	Comp. Motor Input	Sensible To Total Ratio (S/T)			Total Cool Cap.	Comp. Motor Input	Sensible To Total Ratio (S/T)			Total Cool Cap.	Comp. Motor Input	Sensible To Total Ratio (S/T)		
				Dry Bulb					Dry Bulb					Dry Bulb					Dry Bulb		
cfm	kBtuh	kW	75°F	80°F	85°F	kBtuh	kW	75°F	80°F	85°F	kBtuh	kW	75°F	80°F	85°F	kBtuh	kW	75°F	80°F	85°F	
63°F	3200	121.2	7.37	0.68	0.82	0.96	112.6	8.36	0.69	0.84	0.98	103.3	9.48	0.7	0.86	0.99	93.3	10.77	0.7	0.89	1
	4000	129.1	7.41	0.74	0.9	1	120	8.38	0.75	0.92	1	110.1	9.51	0.76	0.95	1	100	10.78	0.78	0.97	1
	4800	135.3	7.46	0.79	0.96	1	125.6	8.42	0.81	0.98	1	116.3	9.55	0.83	0.99	1	106.4	10.85	0.86	1	1
67°F	3200	130.9	7.43	0.53	0.66	0.79	121.8	8.39	0.53	0.66	0.8	112.3	9.52	0.52	0.67	0.82	101.9	10.81	0.52	0.68	0.85
	4000	138.7	7.47	0.56	0.71	0.86	129.1	8.45	0.57	0.72	0.88	119	9.56	0.57	0.74	0.91	108	10.85	0.57	0.76	0.94
	4800	144.5	7.53	0.6	0.77	0.93	134.2	8.47	0.6	0.78	0.95	123.6	9.58	0.6	0.8	0.98	112.5	10.89	0.61	0.83	0.99
71°F	3200	140.7	7.49	0.4	0.52	0.64	131.3	8.46	0.38	0.52	0.64	121.4	9.57	0.37	0.51	0.65	110.7	10.87	0.35	0.51	0.66
	4000	148.8	7.55	0.41	0.55	0.69	138.7	8.51	0.4	0.55	0.7	128.3	9.63	0.39	0.56	0.72	117	10.92	0.38	0.56	0.74
	4800	154.6	7.61	0.43	0.59	0.74	144	8.56	0.42	0.59	0.76	133.3	9.67	0.41	0.6	0.78	121.5	10.97	0.41	0.61	0.81

10 TON - HEATING LDT122H4E

Indoor Coil Air Volume 70°F Dry Bulb cfm	Air Temperature Entering Outdoor Coil									
	65°F		45°F		25°F		5°F		-15°F	
	Total Heating Capacity	Comp. Motor Input	Total Heating Capacity	Comp. Motor Input	Total Heating Capacity	Comp. Motor Input	Total Heating Capacity	Comp. Motor Input	Total Heating Capacity	Comp. Motor Input
	kBtuh	kW	kBtuh	kW	kBtuh	kW	kBtuh	kW	kBtuh	kW
3200	147.7	9.01	110.3	8.01	79.4	7.25	53.8	6.66	26.9	6.18
4000	152.3	8.23	112.7	7.44	81.7	6.89	55.5	6.43	28.1	6.00
4800	155.7	7.73	115.8	7.10	84.1	6.67	57.7	6.30	29.5	5.95

COOLING/HEATING RATINGS

NOTE – For Temperatures and Capacities not shown in tables, see bulletin – Cooling Unit Rating Table Correction Factor Data in Miscellaneous Engineering Data section.

12.5 TON - COOLING LDT150H4E (1 COMPRESSOR - PART LOAD)

Entering Wet Bulb Temperature	Total Air Volume	Outdoor Air Temperature Entering Outdoor Coil																			
		65°F					75°F					85°F					95°F				
		Total Cool Cap.	Comp. Motor Input	Sensible To Total Ratio (S/T)			Total Cool Cap.	Comp. Motor Input	Sensible To Total Ratio (S/T)			Total Cool Cap.	Comp. Motor Input	Sensible To Total Ratio (S/T)			Total Cool Cap.	Comp. Motor Input	Sensible To Total Ratio (S/T)		
				Dry Bulb					Dry Bulb					Dry Bulb					Dry Bulb		
cfm	kBtuh	kW	75°F	80°F	85°F	kBtuh	kW	75°F	80°F	85°F	kBtuh	kW	75°F	80°F	85°F	kBtuh	kW	75°F	80°F	85°F	
63°F	2400	49.2	2.35	0.67	0.79	0.91	46	2.71	0.67	0.8	0.93	42.7	3.13	0.67	0.81	0.95	38.9	3.61	0.67	0.82	0.97
	3000	52.7	2.33	0.71	0.85	0.98	49.5	2.7	0.72	0.87	1	45.9	3.11	0.72	0.88	1	42	3.58	0.73	0.91	1
	3600	55.4	2.31	0.76	0.91	1	52.2	2.68	0.77	0.93	1	48.4	3.1	0.78	0.95	1	44.4	3.58	0.79	0.98	1
67°F	2400	53.2	2.32	0.53	0.65	0.76	50	2.69	0.52	0.64	0.76	46.6	3.11	0.51	0.64	0.77	42.8	3.59	0.5	0.64	0.78
	3000	56.9	2.31	0.56	0.69	0.82	53.6	2.67	0.55	0.69	0.83	49.9	3.1	0.55	0.7	0.85	45.8	3.57	0.54	0.7	0.87
	3600	59.7	2.3	0.59	0.73	0.88	56.2	2.66	0.58	0.74	0.9	52.3	3.08	0.58	0.75	0.91	48	3.56	0.58	0.76	0.94
71°F	2400	57.5	2.31	0.41	0.52	0.62	54.1	2.66	0.4	0.51	0.62	50.6	3.08	0.38	0.5	0.62	46.7	3.57	0.36	0.5	0.62
	3000	61.4	2.29	0.43	0.55	0.67	57.8	2.65	0.41	0.54	0.67	54	3.07	0.4	0.54	0.68	49.8	3.55	0.38	0.53	0.68
	3600	64.3	2.28	0.44	0.58	0.71	60.5	2.64	0.43	0.57	0.72	56.5	3.06	0.42	0.58	0.73	52.2	3.54	0.4	0.58	0.74

12.5 TON - COOLING LDT150H4E (2 COMPRESSORS - PART LOAD / FULL LOAD)

Entering Wet Bulb Temperature	Total Air Volume	Outdoor Air Temperature Entering Outdoor Coil																			
		85°F					95°F					105°F					115°F				
		Total Cool Cap.	Comp. Motor Input	Sensible To Total Ratio (S/T)			Total Cool Cap.	Comp. Motor Input	Sensible To Total Ratio (S/T)			Total Cool Cap.	Comp. Motor Input	Sensible To Total Ratio (S/T)			Total Cool Cap.	Comp. Motor Input	Sensible To Total Ratio (S/T)		
				Dry Bulb					Dry Bulb					Dry Bulb					Dry Bulb		
cfm	kBtuh	kW	75°F	80°F	85°F	kBtuh	kW	75°F	80°F	85°F	kBtuh	kW	75°F	80°F	85°F	kBtuh	kW	75°F	80°F	85°F	
63°F	3000	111.9	7.78	0.68	0.82	0.93	103.3	8.85	0.68	0.83	0.95	94.3	10.13	0.69	0.85	0.96	84.4	11.63	0.7	0.88	0.98
	3600	118.1	7.77	0.72	0.87	0.97	109.4	8.89	0.73	0.89	0.98	100	10.15	0.74	0.91	1	90.3	11.63	0.76	0.93	1
	4200	123.5	7.78	0.76	0.92	1	114.5	8.89	0.77	0.93	1	105.4	10.15	0.79	0.95	1	95.4	11.61	0.82	0.97	1
67°F	3000	121	7.78	0.53	0.65	0.78	112.3	8.88	0.52	0.66	0.79	102.8	10.15	0.52	0.67	0.81	92.8	11.62	0.51	0.68	0.84
	3600	127.5	7.8	0.55	0.69	0.84	118.2	8.89	0.55	0.7	0.86	108.4	10.16	0.55	0.72	0.88	97.8	11.64	0.55	0.73	0.91
	4200	132.5	7.81	0.58	0.74	0.89	123	8.92	0.58	0.75	0.91	112.8	10.19	0.58	0.77	0.92	101.8	11.63	0.58	0.79	0.94
71°F	3000	130.6	7.8	0.39	0.52	0.63	121.4	8.89	0.38	0.51	0.64	112	10.18	0.37	0.51	0.64	101.5	11.62	0.35	0.5	0.65
	3600	137.2	7.82	0.41	0.54	0.67	127.6	8.91	0.4	0.54	0.68	117.5	10.18	0.38	0.54	0.69	106.7	11.65	0.37	0.54	0.71
	4200	142.4	7.84	0.42	0.57	0.71	132.4	8.92	0.41	0.57	0.73	122	10.19	0.4	0.57	0.74	110.6	11.67	0.39	0.58	0.77

12.5 TON - COOLING LDT150H4E (2 COMPRESSORS - FULL LOAD)

Entering Wet Bulb Temperature	Total Air Volume	Outdoor Air Temperature Entering Outdoor Coil																			
		85°F					95°F					105°F					115°F				
		Total Cool Cap.	Comp. Motor Input	Sensible To Total Ratio (S/T)			Total Cool Cap.	Comp. Motor Input	Sensible To Total Ratio (S/T)			Total Cool Cap.	Comp. Motor Input	Sensible To Total Ratio (S/T)			Total Cool Cap.	Comp. Motor Input	Sensible To Total Ratio (S/T)		
				Dry Bulb					Dry Bulb					Dry Bulb					Dry Bulb		
cfm	kBtuh	kW	75°F	80°F	85°F	kBtuh	kW	75°F	80°F	85°F	kBtuh	kW	75°F	80°F	85°F	kBtuh	kW	75°F	80°F	85°F	
63°F	3800	136.7	8.54	0.7	0.84	0.98	127	9.72	0.7	0.86	0.99	116.8	11.02	0.71	0.88	1	106	12.6	0.73	0.91	1
	4400	142.3	8.56	0.73	0.89	1	132.2	9.75	0.74	0.91	1	121.6	11.04	0.76	0.94	1	110.6	12.59	0.78	0.97	1
	5000	146.7	8.6	0.77	0.94	1	136.7	9.75	0.78	0.96	1	125.9	11.05	0.8	0.98	1	115.1	12.58	0.83	1	1
67°F	3800	147	8.59	0.54	0.67	0.81	136.9	9.74	0.54	0.68	0.82	126.7	11.06	0.54	0.69	0.85	115.5	12.61	0.54	0.71	0.87
	4400	152.5	8.62	0.57	0.71	0.85	142.1	9.79	0.56	0.72	0.88	131.4	11.08	0.56	0.74	0.9	119.8	12.64	0.57	0.76	0.94
	5000	156.8	8.64	0.58	0.74	0.9	146.3	9.81	0.59	0.76	0.93	135	11.11	0.59	0.78	0.95	123.1	12.63	0.6	0.8	0.98
71°F	3800	157.6	8.64	0.41	0.53	0.65	147.3	9.8	0.4	0.53	0.66	136.7	11.13	0.38	0.53	0.67	125.1	12.65	0.37	0.53	0.68
	4400	163.3	8.68	0.41	0.55	0.69	152.6	9.84	0.41	0.56	0.7	141.4	11.15	0.4	0.56	0.71	129.6	12.69	0.39	0.57	0.73
	5000	167.7	8.7	0.42	0.57	0.72	156.9	9.87	0.42	0.58	0.74	145.2	11.19	0.41	0.58	0.76	132.9	12.69	0.4	0.59	0.78

12.5 TON - HEATING LDT150H4E

Indoor Coil Air Volume 70°F Dry Bulb cfm	Air Temperature Entering Outdoor Coil									
	65°F		45°F		25°F		5°F		-15°F	
	Total Heating Capacity	Comp. Motor Input	Total Heating Capacity	Comp. Motor Input	Total Heating Capacity	Comp. Motor Input	Total Heating Capacity	Comp. Motor Input	Total Heating Capacity	Comp. Motor Input
	kBtuh	kW	kBtuh	kW	kBtuh	kW	kBtuh	kW	kBtuh	kW
3800	165.2	10.12	122.9	9.10	88.0	8.23	59.6	7.57	29.5	7.07
4400	168.0	9.53	125.0	8.67	89.7	7.94	60.9	7.38	30.4	6.99
5000	172.0	9.10	128.2	8.36	92.5	7.73	63.2	7.25	32.1	6.94

BLOWER DATA

BLOWER TABLE INCLUDES RESISTANCE FOR BASE UNIT ONLY (NO HEAT SECTION) WITH DRY INDOOR COIL AND AIR FILTERS IN PLACE.

FOR ALL UNITS ADD:

- 1 – Wet indoor coil air resistance of selected unit.
 - 2 – Any factory installed options air resistance (heat section, Economizer, etc.)
 - 3 – Any field installed accessories air resistance (duct resistance, diffuser, etc.)
- See Page 29 for wet coil and option/accessory air resistance data.

Maximum Static Pressure With Gas Heat - 2.0 in. w.g.

Minimum Air Volume Required For Different Gas Heat Sizes:

Standard - 2150 cfm; Medium - 2250 cfm; High - 2600 cfm

Total Air Volume cfm	Total Static Pressure - in. w.g.													
	0.2		0.4		0.6		0.8		1.0		1.2		1.4	
	RPM	Watts	RPM	Watts	RPM	Watts	RPM	Watts	RPM	Watts	RPM	Watts	RPM	Watts
1750	759	223	864	298	961	359	1049	420	1128	508	1199	607	1260	704
2000	846	271	943	345	1035	410	1117	488	1189	598	1255	704	1313	804
2250	945	303	1030	391	1111	476	1184	577	1247	697	1310	806	1367	905
2500	1035	366	1109	476	1180	583	1245	688	1306	797	1368	903	1426	1008
2750	1113	476	1182	601	1248	715	1310	809	1371	902	1432	1011	1491	1129
3000	1195	596	1261	718	1324	827	1385	922	1444	1024	1503	1146	1559	1279
3250	1282	711	1346	827	1406	935	1464	1044	1521	1167	1576	1306	1629	1460
3500	1372	821	1432	940	1489	1060	1544	1192	1598	1337	1650	1494	1700	1663
3750	1461	949	1517	1081	1571	1221	1624	1373	1675	1532	1725	1700	1773	1875
4000	1549	1109	1602	1256	1653	1413	1703	1576	1753	1743	1801	1916	1847	2091
4250	1637	1298	1687	1458	1735	1625	1784	1795	1831	1966	1877	2139	1923	2310
4500	1724	1510	1772	1678	1818	1851	1864	2023	1910	2195	1955	2365	2000	2530
4750	1811	1738	1856	1910	1901	2083	1946	2254	1990	2423	2034	2587	2079	2746
5000	1897	1973	1941	2144	1985	2314	2028	2480	2071	2644	2114	2805	2158	2959
5250	1983	2205	2026	2373	2069	2538	2111	2699	2153	2860	2195	3017	---	---
5500	2070	2428	2112	2595	2153	2756	2194	2912	---	---	---	---	---	---
5750	2156	2643	2197	2809	---	---	---	---	---	---	---	---	---	---

Total Air Volume cfm	Total Static Pressure - in. w.g.											
	1.6		1.8		2.0		2.2		2.4		2.6	
	RPM	Watts	RPM	Watts	RPM	Watts	RPM	Watts	RPM	Watts	RPM	Watts
1750	1316	793	1373	875	1432	963	1491	1064	1548	1175	1604	1300
2000	1368	894	1425	982	1483	1081	1540	1196	1596	1322	1650	1458
2250	1423	1001	1480	1101	1537	1216	1593	1344	1647	1483	1700	1629
2500	1483	1117	1539	1236	1594	1368	1648	1509	1700	1657	1752	1810
2750	1547	1256	1601	1394	1654	1539	1705	1690	1756	1846	1806	2004
3000	1612	1425	1664	1577	1715	1734	1765	1893	1815	2053	1864	2213
3250	1680	1623	1729	1787	1778	1949	1828	2110	1876	2269	1925	2426
3500	1748	1835	1796	2003	1844	2165	1893	2324	1942	2479	1991	2633
3750	1819	2048	1866	2214	1914	2374	1963	2530	2012	2684	2061	2837
4000	1893	2260	1940	2423	1988	2581	2036	2737	2084	2891	2134	3044
4250	1969	2475	2016	2634	2063	2790	2111	2945	2159	3098	---	---
4500	2046	2689	2093	2844	2140	2998	2187	3153	---	---	---	---
4750	2124	2900	2170	3053	---	---	---	---	---	---	---	---
5000	2203	3111	---	---	---	---	---	---	---	---	---	---
5250	---	---	---	---	---	---	---	---	---	---	---	---
5500	---	---	---	---	---	---	---	---	---	---	---	---

BLOWER DATA

FACTORY INSTALLED OPTIONS/FIELD INSTALLED ACCESSORY AIR RESISTANCE - in. w.g.

Air Volume cfm	Wet Indoor Coil		Gas Heat Exchanger			Economizer	Filters			Return Air Adaptor Plate
	092, 102	122	Standard Heat	Medium Heat	High Heat		MERV 8	MERV 13	MERV 16	
1750	0.04	0.04	0.06	0.02	0.02	0.05	0.01	0.03	0.06	0.00
2000	0.05	0.05	0.07	0.05	0.06	0.06	0.01	0.03	0.08	0.00
2250	0.06	0.06	0.07	0.07	0.08	0.08	0.01	0.04	0.09	0.00
2500	0.07	0.07	0.09	0.10	0.11	0.11	0.01	0.05	0.10	0.00
2750	0.08	0.08	0.09	0.11	0.12	0.12	0.02	0.05	0.11	0.00
3000	0.10	0.09	0.11	0.12	0.13	0.13	0.02	0.06	0.12	0.02
3250	0.11	0.10	0.12	0.15	0.16	0.15	0.02	0.06	0.13	0.02
3500	0.12	0.11	0.12	0.16	0.17	0.15	0.03	0.07	0.15	0.04
3750	0.14	0.13	0.14	0.19	0.20	0.15	0.03	0.08	0.16	0.07
4000	0.15	0.14	0.14	0.21	0.22	0.19	0.04	0.08	0.17	0.09
4250	0.17	0.15	0.14	0.24	0.28	0.19	0.04	0.09	0.19	0.11
4500	0.19	0.17	0.15	0.26	0.32	0.22	0.04	0.09	0.20	0.12
4750	0.20	0.18	0.16	0.29	0.37	0.25	0.05	0.10	0.21	0.16
5000	0.22	0.20	0.16	0.34	0.43	0.29	0.06	0.10	0.23	0.18
5250	0.24	0.22	0.16	0.37	0.47	0.32	0.06	0.11	0.24	0.19
5500	0.25	0.23	0.18	0.44	0.54	0.34	0.07	0.12	0.25	0.22
5750	0.27	0.25	0.19	0.49	0.59	0.45	0.07	0.12	0.27	0.25
6000	0.29	0.27	0.20	0.54	0.64	0.52	0.08	0.13	0.28	0.27

POWER EXHAUST FAN PERFORMANCE

Return Air System Static Pressure in. w.g.	Air Volume Exhausted cfm
0	3175
0.05	2955
0.10	2685
0.15	2410
0.20	2165
0.25	1920
0.30	1420
0.35	1200

BLOWER DATA

CEILING DIFFUSERS AIR RESISTANCE - in. w.g.

Unit Size	RTD11 Step-Down Diffuser				FD11 Flush Diffuser
	Air Volume cfm	2 Ends Open	1 Side, 2 Ends Open	All Ends & Sides Open	
078 & 092 Models	2400	0.21	0.18	0.15	0.14
	2600	0.24	0.21	0.18	0.17
	2800	0.27	0.24	0.21	0.20
	3000	0.32	0.29	0.25	0.25
	3200	0.41	0.37	0.32	0.31
	3400	0.50	0.45	0.39	0.37
	3600	0.61	0.54	0.48	0.44
	3800	0.73	0.63	0.57	0.51
102 & 122 Models	3600	0.36	0.28	0.23	0.15
	3800	0.40	0.32	0.26	0.18
	4000	0.44	0.36	0.29	0.21
	4200	0.49	0.40	0.33	0.24
	4400	0.54	0.44	0.37	0.27
	4600	0.60	0.49	0.42	0.31
	4800	0.65	0.53	0.46	0.35
	5000	0.69	0.58	0.50	0.39
150 Models	5200	0.75	0.62	0.54	0.43
	4200	0.22	0.19	0.16	0.10
	4400	0.28	0.24	0.20	0.12
	4600	0.34	0.29	0.24	0.15
	4800	0.40	0.34	0.29	0.19
	5000	0.46	0.39	0.34	0.23
	5200	0.52	0.44	0.39	0.27
	5400	0.58	0.49	0.43	0.31
5600	0.64	0.54	0.47	0.35	
5800	0.70	0.59	0.51	0.39	

CEILING DIFFUSER AIR THROW DATA

Model No.	Air Volume cfm	¹ Effective Throw Range	
		RTD11 Step-Down	FD11 Flush
		ft.	ft.
078, 092 Models	2600	24 - 29	19 - 24
	2800	25 - 30	20 - 28
	3000	27 - 33	21 - 29
	3200	28 - 35	22 - 29
	3400	30 - 37	22 - 30
102, 122 Models	3600	25 - 33	22 - 29
	3800	27 - 35	22 - 30
	4000	29 - 37	24 - 33
	4200	32 - 40	26 - 35
	4400	34 - 42	28 - 37
150 Models	5600	39 - 49	28 - 37
	5800	42 - 51	29 - 38
	6000	44 - 54	40 - 50
	6200	45 - 55	42 - 51
	6400	46 - 55	43 - 52
6600	47 - 56	45 - 56	

¹ Throw is the horizontal or vertical distance an air stream travels on leaving the outlet or diffuser before the maximum velocity is reduced to 50 ft. per minute. Four sides open.

ELECTRICAL DATA**6.5 TON**

Model No.		LDT078H4E		
		208/230V-3ph	460V-3ph	575V-3ph
¹ Voltage - 60Hz				
Compressor 1 (Non-Inverter)	Rated Load Amps	12.9	7.1	4.6
	Locked Rotor Amps	105	62	39
Compressor 2 (Non-Inverter)	Rated Load Amps	8.5	3.8	3.5
	Locked Rotor Amps	70	31	27
Outdoor Fan Motors (2)	Full Load Amps (2 ECM)	2.8	1.4	1.1
	Total	5.6	2.8	2.2
Power Exhaust (1) 0.33 HP	Full Load Amps	2.4	1.3	1
Service Outlet 115V GFI (amps)		15	15	20
Indoor Blower Motor	Horsepower	3.75	3.75	3.75
	Full Load Amps	8.7	4.7	4.1
² Maximum Overcurrent Protection (MOCP)	Unit Only	50	25	20
	With (1) 0.33 HP Power Exhaust	50	25	20
³ Minimum Circuit Ampacity (MCA)	Unit Only	39	21	16
	With (1) 0.33 HP Power Exhaust	42	22	17

NOTE - All units have a minimum Short Circuit Current Rating (SCCR) of 5000 amps.

¹ Extremes of operating range are plus and minus 10% of line voltage.² HACR type breaker or fuse.³ Refer to National or Canadian Electrical Code manual to determine wire, fuse and disconnect size requirements.**ELECTRICAL DATA****7.5 TON**

Model No.		LDT092H4E		
		208/230V-3ph	460V-3ph	575V-3ph
¹ Voltage - 60Hz				
Compressor 1 (Non-Inverter)	Rated Load Amps	12.9	7.1	4.6
	Locked Rotor Amps	105	62	39
Compressor 2 (Non-Inverter)	Rated Load Amps	13.7	6.1	4.8
	Locked Rotor Amps	83.1	43	33
Outdoor Fan Motors (2)	Full Load Amps (2 ECM)	2.8	1.4	1.1
	Total	5.6	2.8	2.2
Power Exhaust (1) 0.33 HP	Full Load Amps	2.4	1.3	1
Service Outlet 115V GFI (amps)		15	15	20
Indoor Blower Motor	Horsepower	3.75	3.75	3.75
	Full Load Amps	8.7	4.7	4.1
² Maximum Overcurrent Protection (MOCP)	Unit Only	50	25	20
	With (1) 0.33 HP Power Exhaust	60	30	20
³ Minimum Circuit Ampacity (MCA)	Unit Only	45	23	17
	With (1) 0.33 HP Power Exhaust	47	24	18

NOTE - All units have a minimum Short Circuit Current Rating (SCCR) of 5000 amps.

¹ Extremes of operating range are plus and minus 10% of line voltage.² HACR type breaker or fuse.³ Refer to National or Canadian Electrical Code manual to determine wire, fuse and disconnect size requirements.

ELECTRICAL DATA**8.5 TON**

Model No.		LDT102H4E		
		208/230V-3ph	460V-3ph	575V-3ph
¹ Voltage - 60Hz				
Compressor 1 (Non-Inverter)	Rated Load Amps	12.9	7.1	4.6
	Locked Rotor Amps	105	62	39
Compressor 2 (Non-Inverter)	Rated Load Amps	16	7.8	5.7
	Locked Rotor Amps	110	52	38.9
Outdoor Fan Motors (2)	Full Load Amps (2 ECM)	2.8	1.4	1.1
	Total	5.6	2.8	2.2
Power Exhaust (1) 0.33 HP	Full Load Amps	2.4	1.3	1
Service Outlet 115V GFI (amps)		15	15	20
Indoor Blower Motor	Horsepower	3.75	3.75	3.75
	Full Load Amps	8.7	4.7	4.1
² Maximum Overcurrent Protection (MOCP)	Unit Only	60	30	20
	With (1) 0.33 HP Power Exhaust	60	30	20
³ Minimum Circuit Ampacity (MCA)	Unit Only	48	25	19
	With (1) 0.33 HP Power Exhaust	50	26	20

NOTE - All units have a minimum Short Circuit Current Rating (SCCR) of 5000 amps.

¹ Extremes of operating range are plus and minus 10% of line voltage.² HACR type breaker or fuse.³ Refer to National or Canadian Electrical Code manual to determine wire, fuse and disconnect size requirements.**ELECTRICAL DATA****10 TON**

Model No.		LDT122H4E		
		208/230V-3ph	460V-3ph	575V-3ph
¹ Voltage - 60Hz				
Compressor 1 (Non-Inverter)	Rated Load Amps	16.7	7.1	5.7
	Locked Rotor Amps	110	54.7	47.8
Compressor 2 (Non-Inverter)	Rated Load Amps	19.6	8.2	6.6
	Locked Rotor Amps	136	66.1	55.3
Outdoor Fan Motors (2)	Full Load Amps (3 ECM)	2.8	1.4	1.1
	Total	5.6	2.8	2.2
Power Exhaust (1) 0.33 HP	Full Load Amps	2.4	1.3	1
Service Outlet 115V GFI (amps)		15	15	20
Indoor Blower Motor	Horsepower	3.75	3.75	3.75
	Full Load Amps	8.7	4.7	4.1
² Maximum Overcurrent Protection (MOCP)	Unit Only	70	30	25
	With (1) 0.33 HP Power Exhaust	80	35	25
³ Minimum Circuit Ampacity (MCA)	Unit Only	59	27	22
	With (1) 0.33 HP Power Exhaust	61	28	23

NOTE - All units have a minimum Short Circuit Current Rating (SCCR) of 5000 amps.

¹ Extremes of operating range are plus and minus 10% of line voltage.² HACR type breaker or fuse.³ Refer to National or Canadian Electrical Code manual to determine wire, fuse and disconnect size requirements.

ELECTRICAL DATA**12.5 TON**

Model No.		LDT150H4E		
		208/230V-3ph	460V-3ph	575V-3ph
¹ Voltage - 60Hz				
Compressor 1 (Non-Inverter)	Rated Load Amps	17.6	8.5	6.3
	Locked Rotor Amps	136	66.1	55.3
Compressor 2 (Non-Inverter)	Rated Load Amps	22.6	10	7.5
	Locked Rotor Amps	166.2	74.6	54
Outdoor Fan Motors (2)	Full Load Amps (3 ECM)	2.8	1.4	1.1
	Total	5.6	2.8	2.2
Power Exhaust (1) 0.33 HP	Full Load Amps	2.4	1.3	1
Service Outlet 115V GFI (amps)		15	15	20
Indoor Blower Motor	Horsepower	3.75	3.75	3.75
	Full Load Amps	8.7	4.7	4.1
² Maximum Overcurrent Protection (MOCP)	Unit Only	80	35	30
	With (1) 0.33 HP Power Exhaust	80	40	30
³ Minimum Circuit Ampacity (MCA)	Unit Only	63	30	24
	With (1) 0.33 HP Power Exhaust	66	32	25

NOTE - All units have a minimum Short Circuit Current Rating (SCCR) of 5000 amps.

¹ Extremes of operating range are plus and minus 10% of line voltage.

² HACR type breaker or fuse.

³ Refer to National or Canadian Electrical Code manual to determine wire, fuse and disconnect size requirements.

FIELD WIRING NOTES

- For use with copper wiring only
- Field wiring not furnished
- All wiring must conform to NEC or CEC and local electrical codes
- For specific wiring information, please refer to the installation instructions

UNIT CLEARANCES

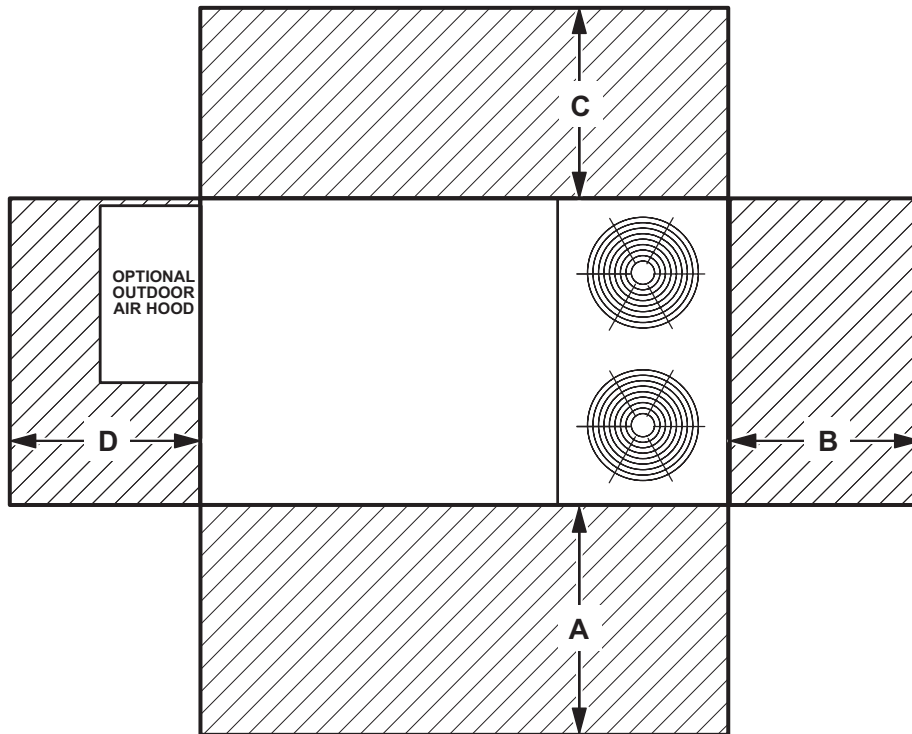

1 Unit Clearance	A		B		C		D		Top Clearance
	in.	mm	in.	mm	in.	mm	in.	mm	
Service Clearance	60	1524	36	914	36	934	60	1524	Unobstructed
Clearance to Combustibles	36	914	1	25	1	25	1	25	
Minimum Operation Clearance	36	914	36	914	36	914	36	914	

NOTE - Entire perimeter of unit base requires support when elevated above the mounting surface.

¹ Service Clearance - Required for removal of serviceable parts.

Clearance to Combustibles - Required clearance to combustible material.

Minimum Operation Clearance - Required clearance for proper unit operation.

OUTDOOR SOUND DATA

Unit Model Number	Octave Band Sound Power Levels dBA, re 10 ⁻¹² Watts Center Frequency - Hz							1 Sound Rating Number (dBA)
	125	250	500	1000	2000	4000	8000	
LDT078, 092, 102	70	79	84	83	77	72	66	88
LDT122, 150	73	74	75	72	66	60	50	85

Note - The octave sound power data does not include tonal corrections.

¹ Sound Rating Number according to AHRI Standard 270-95 or AHRI Standard 370-2001 (includes pure tone penalty). Sound Rating Number is the overall A-Weighted Sound Power Level, (Lwa), dB (100 Hz to 10,000 Hz).

WEIGHT DATA				UNIT
Model Number	Net		Shipping	
	lbs.	kg	lbs.	kg
078 Base Unit	1121	509	1206	548
078 Max. Unit	1264	574	1349	612
092 Base Unit	1121	509	1206	548
092 Max. Unit	1264	574	1349	612
102 Base Unit	1123	510	1208	548
102 Max. Unit	1266	575	1351	613
122 Base Unit	1264	574	1349	612
122 Max. Unit	1407	639	1492	677
150 Base Unit	1264	574	1349	612
150 Max. Unit	1407	639	1492	677

WEIGHT DATA		OPTIONS / ACCESSORIES	
		Shipping Weight	
		lbs.	kg
ECONOMIZER / OUTDOOR AIR / EXHAUST			
Economizer			
Economizer Dampers		60	27
Outdoor Air Hood (downflow)		23	10
Barometric Relief Dampers (downflow)		8	4
Barometric Relief Dampers (low profile horizontal)		20	9
Outdoor Air Dampers			
Motorized		51	23
Manual		39	18
Power Exhaust		31	14
GAS HEAT EXCHANGER (NET WEIGHT)			
Medium Heat (adder over standard heat)		9	5
High Heat (adder over standard heat)		32	15
COMBINATION COIL/HAIL GUARDS			
078/092/102		50	23
122/150		60	27
ROOF CURBS			
Hybrid Roof Curbs, Downflow			
8 in. height		103	47
14 in. height		125	57
18 in. height		147	67
24 in. height		169	77
Adjustable Pitch Curb, Downflow			
14 in. height		169	77
CEILING DIFFUSERS			
Step-Down	RTD11-95S	118	54
	RTD11-135S	135	61
Flush	FD11-95S	118	54
	FD11-135S	135	61
Transitions	C1DIFF30B-1	30	14
	C1DIFF31B-1	32	15

Model No.	CORNER WEIGHTS																CENTER OF GRAVITY							
	AA				BB				CC				DD				EE				FF			
	Base		Max.		Base		Max.		Base		Max.		Base		Max.		Base		Max.		Base		Max.	
	lbs.	kg	lbs.	kg	lbs.	kg	lbs.	kg	lbs.	kg	lbs.	kg	lbs.	kg	lbs.	kg	in.	mm	in.	mm	in.	mm	in.	mm
LDT078	296	134	334	152	248	112	279	127	260	118	293	133	318	144	358	163	44	1118	43	1092	27	686	28	711
LDT092	296	134	334	152	248	112	279	127	260	118	293	133	318	144	358	163	44	1118	43	1092	27	686	28	711
LDT102	297	135	334	152	248	113	280	127	260	118	293	133	318	144	359	163	44	1118	43	1092	27	686	28	711

Base Unit - The unit with NO OPTIONS.

Max. Unit - The unit with ALL OPTIONS Installed (Economizer, etc.).

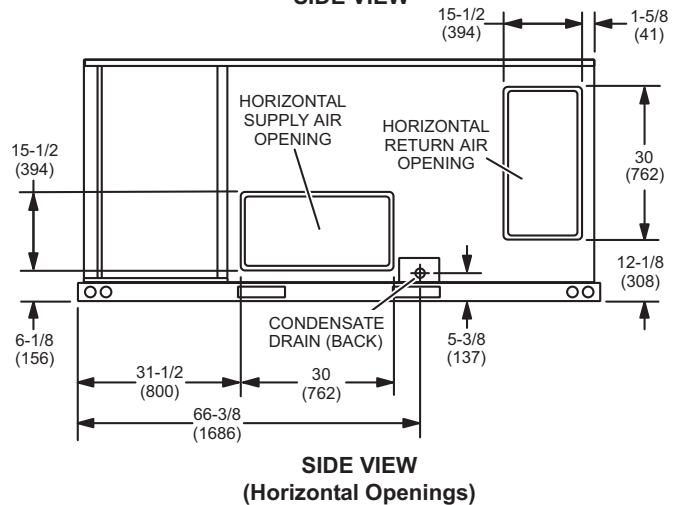
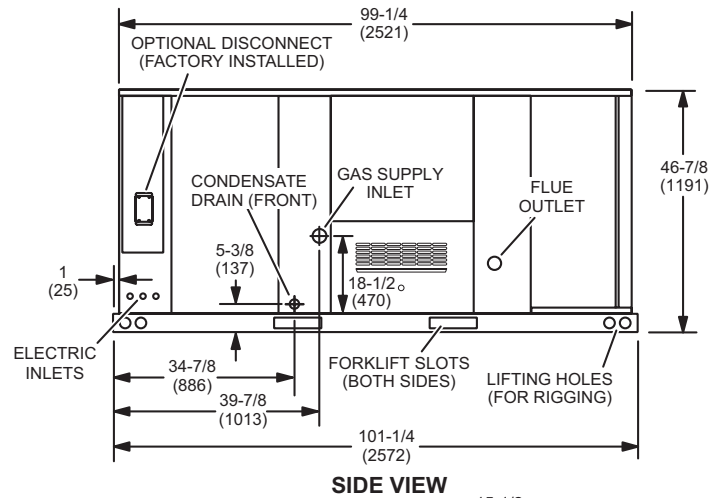
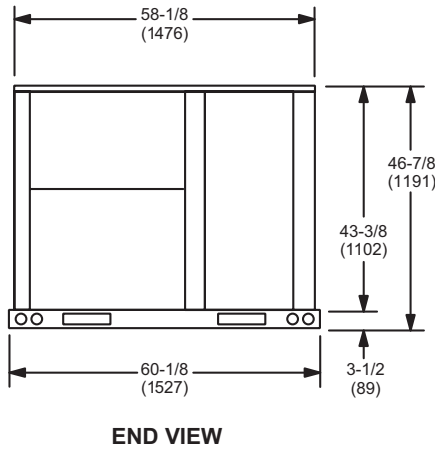
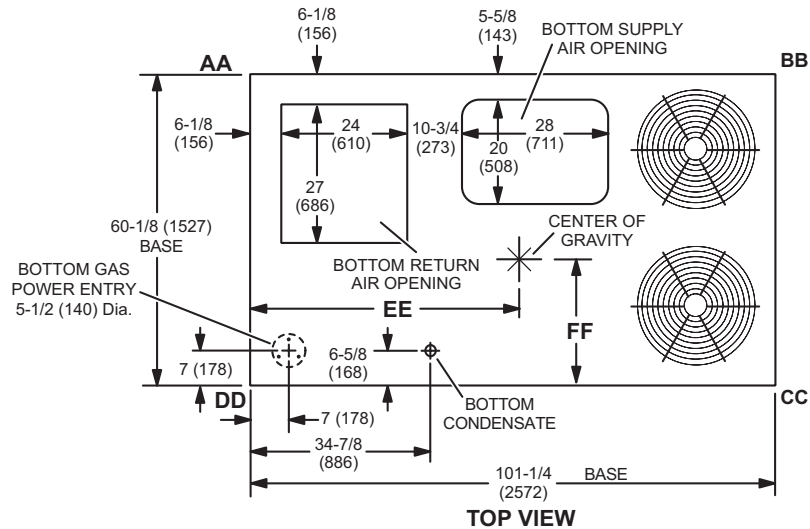

Model No.	CORNER WEIGHTS														CENTER OF GRAVITY									
	AA				BB				CC				DD				EE				FF			
	Base		Max.		Base		Max.		Base		Max.		Base		Max.		Base		Max.		Base		Max.	
	lbs.	kg	lbs.	kg	lbs.	kg	lbs.	kg	lbs.	kg	lbs.	kg	lbs.	kg	lbs.	kg	in.	mm	in.	mm	in.	mm	in.	mm
LDT122	328	149	366	166	284	129	316	144	299	136	333	151	352	160	392	178	56.5	1435	55.5	1010	25.5	648	26.5	673
LDT150	328	149	366	166	284	129	316	144	299	136	333	151	352	160	392	178	56.5	1435	55.5	1010	25.5	648	26.5	673

Base Unit - The unit with NO OPTIONS.

Max. Unit - The unit with ALL OPTIONS Installed (Economizer, etc.).

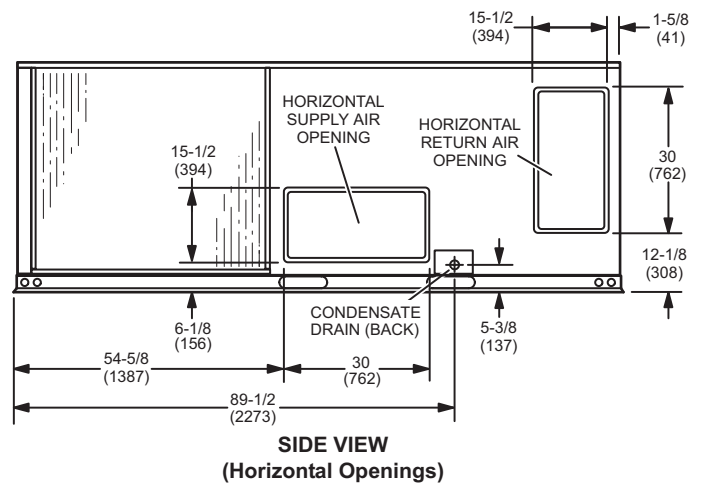
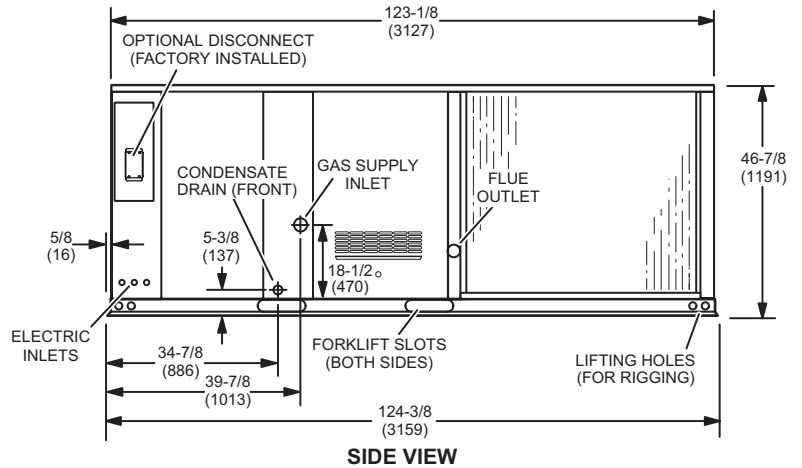
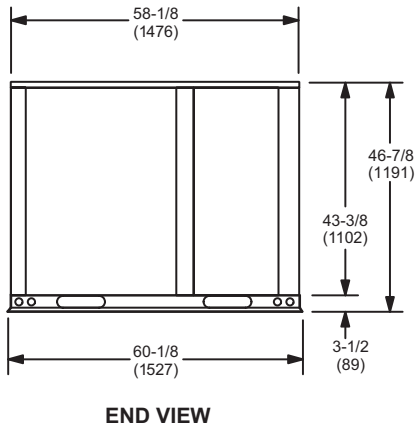
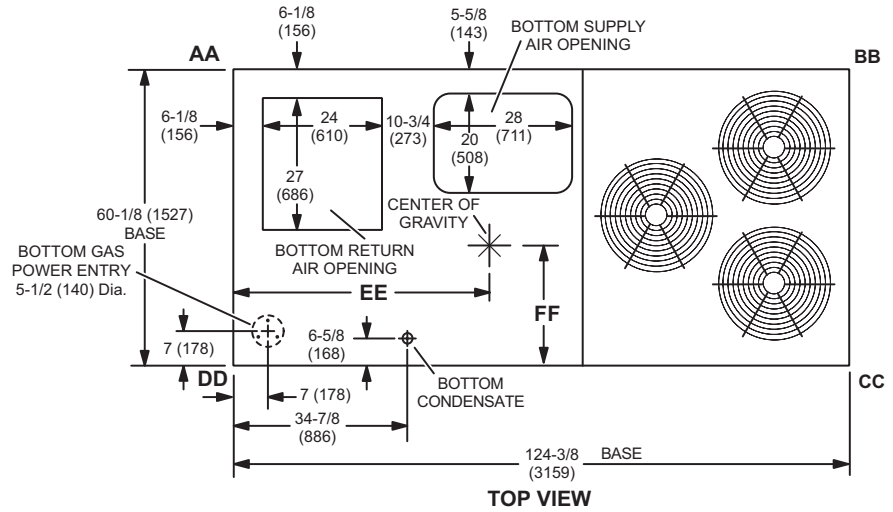

OUTDOOR AIR HOOD DETAIL

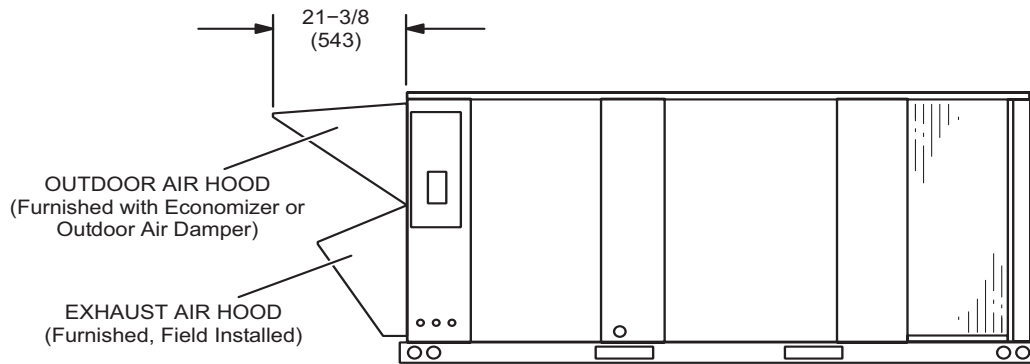

UNIT ON CURB LOCATION - 122 AND 150 MODELS

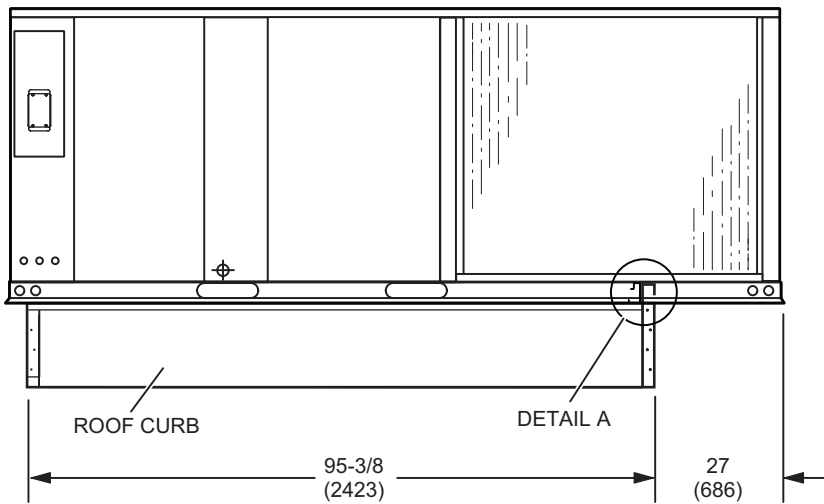

SIDE VIEW

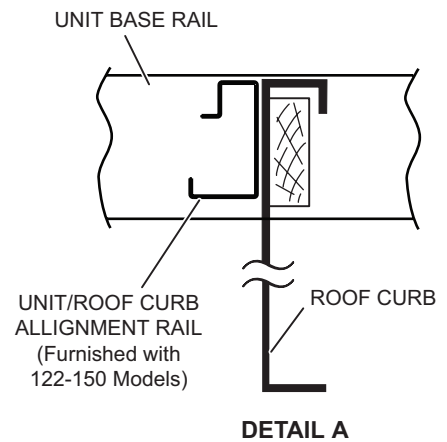

HORIZONTAL ECONOMIZER APPLICATION

(With Furnished Barometric Relief Dampers and Optional Horizontal Discharge Kit - Required)

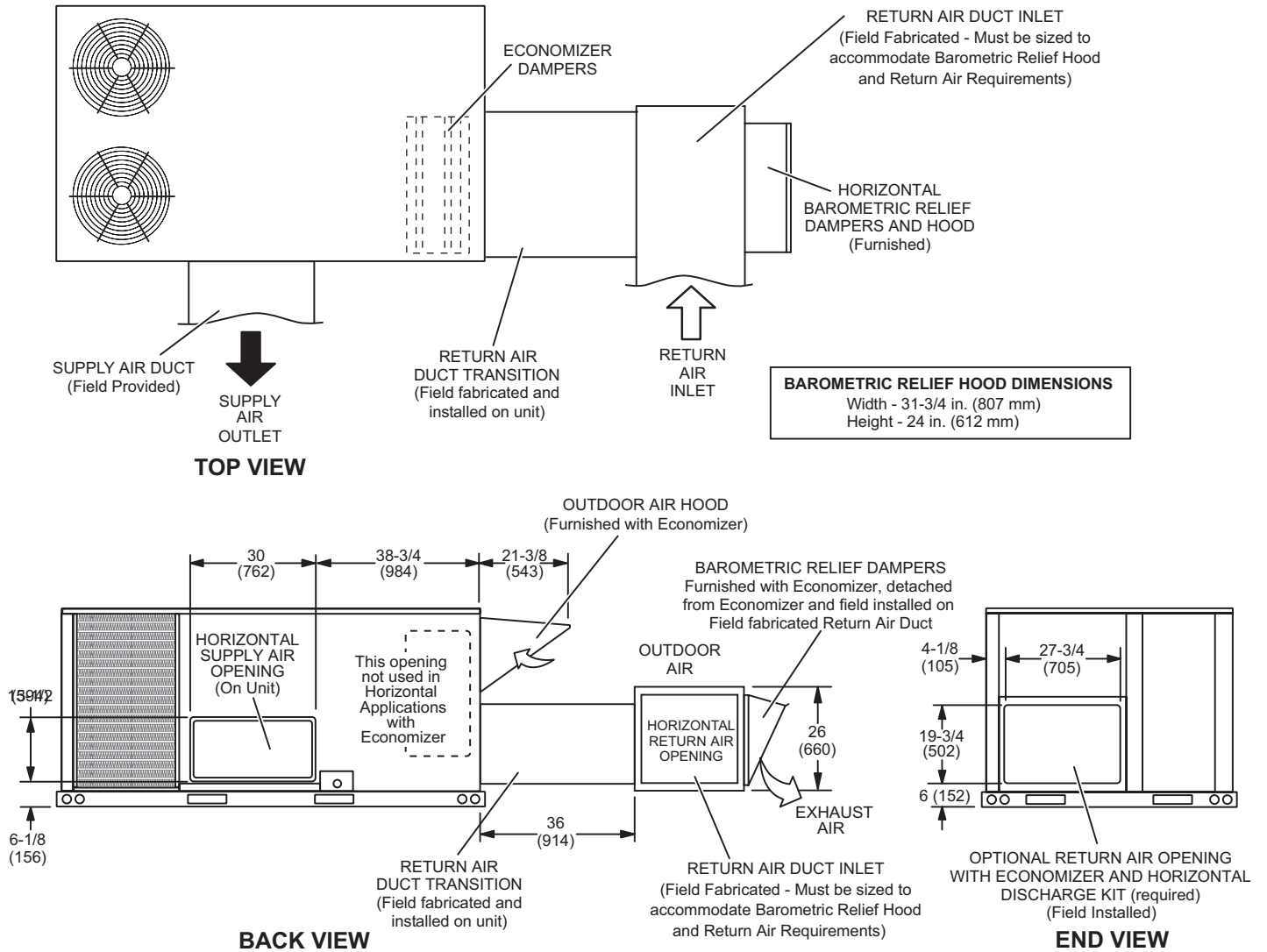

NOTE - Return Air Duct and Transition must be supported.

**BAROMETRIC RELIEF DAMPERS
(Furnished with Economizer)**

(Field installed in horizontal return air duct adjacent to unit)

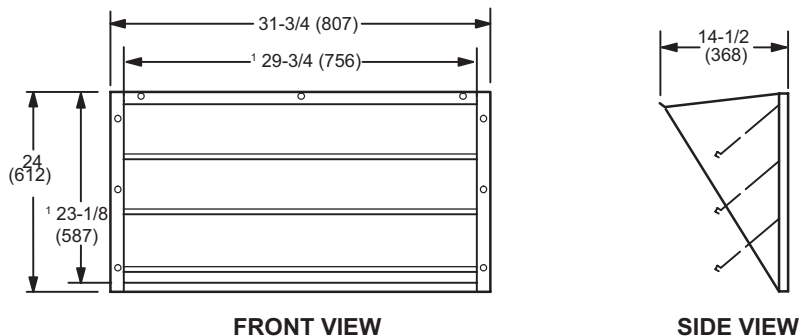

¹ NOTE - Opening size required in return air duct.

HORIZONTAL ECONOMIZER APPLICATION

(with Optional Low Profile Horizontal Barometric Relief Dampers and Horizontal Discharge Kit - Required)

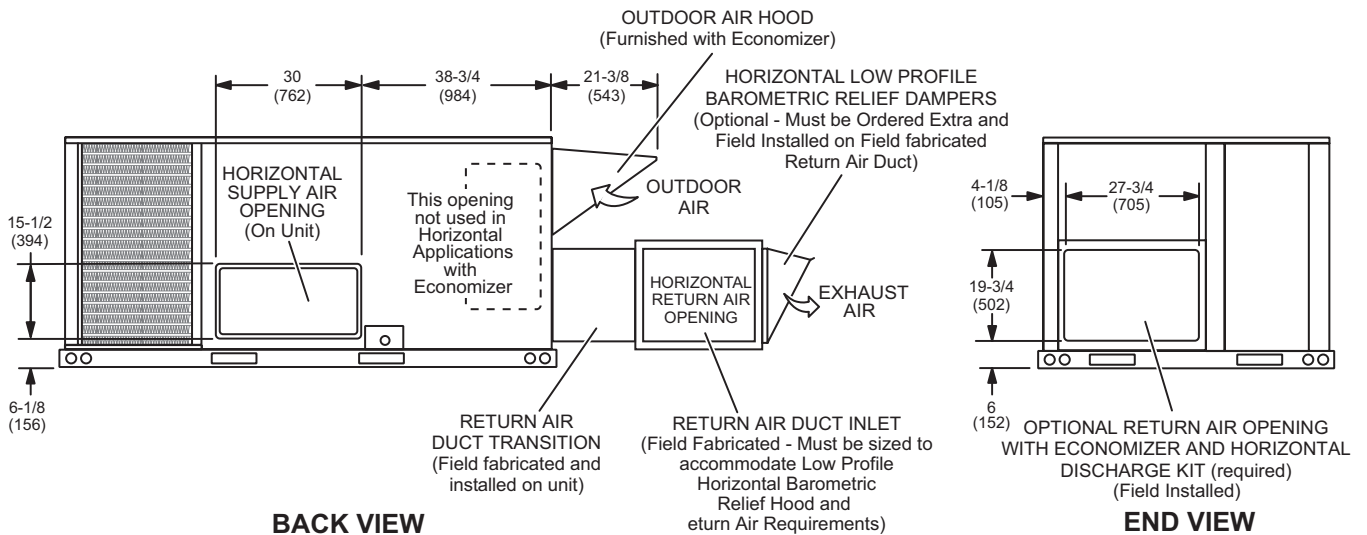
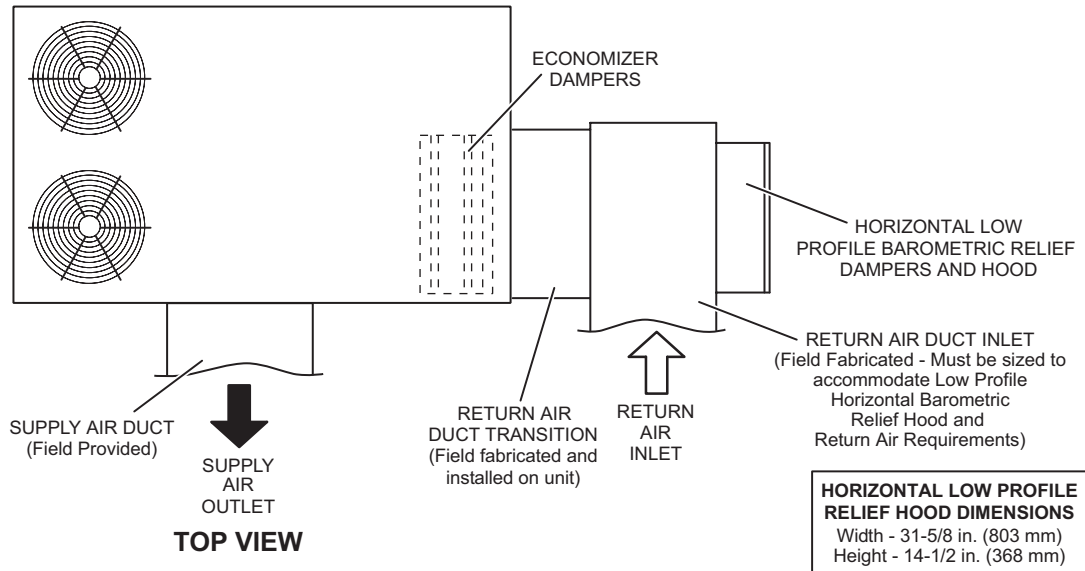

NOTE - Return Air Duct and Transition must be supported.

HORIZONTAL LOW PROFILE BAROMETRIC RELIEF DAMPERS

(Field installed in horizontal return air duct adjacent to unit)

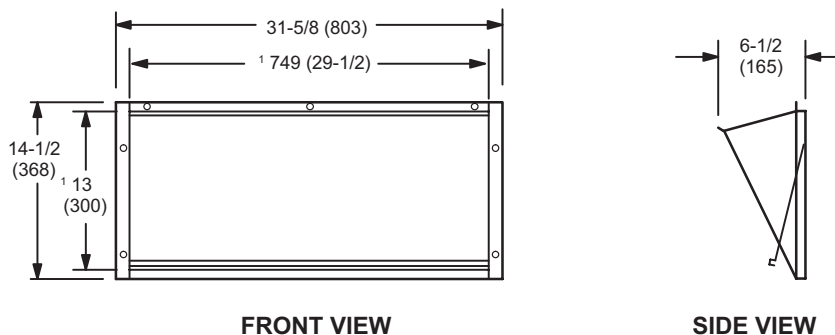

¹ NOTE - Opening size required in return air duct.

HYBRID ROOF CURBS - DOUBLE DUCT OPENING

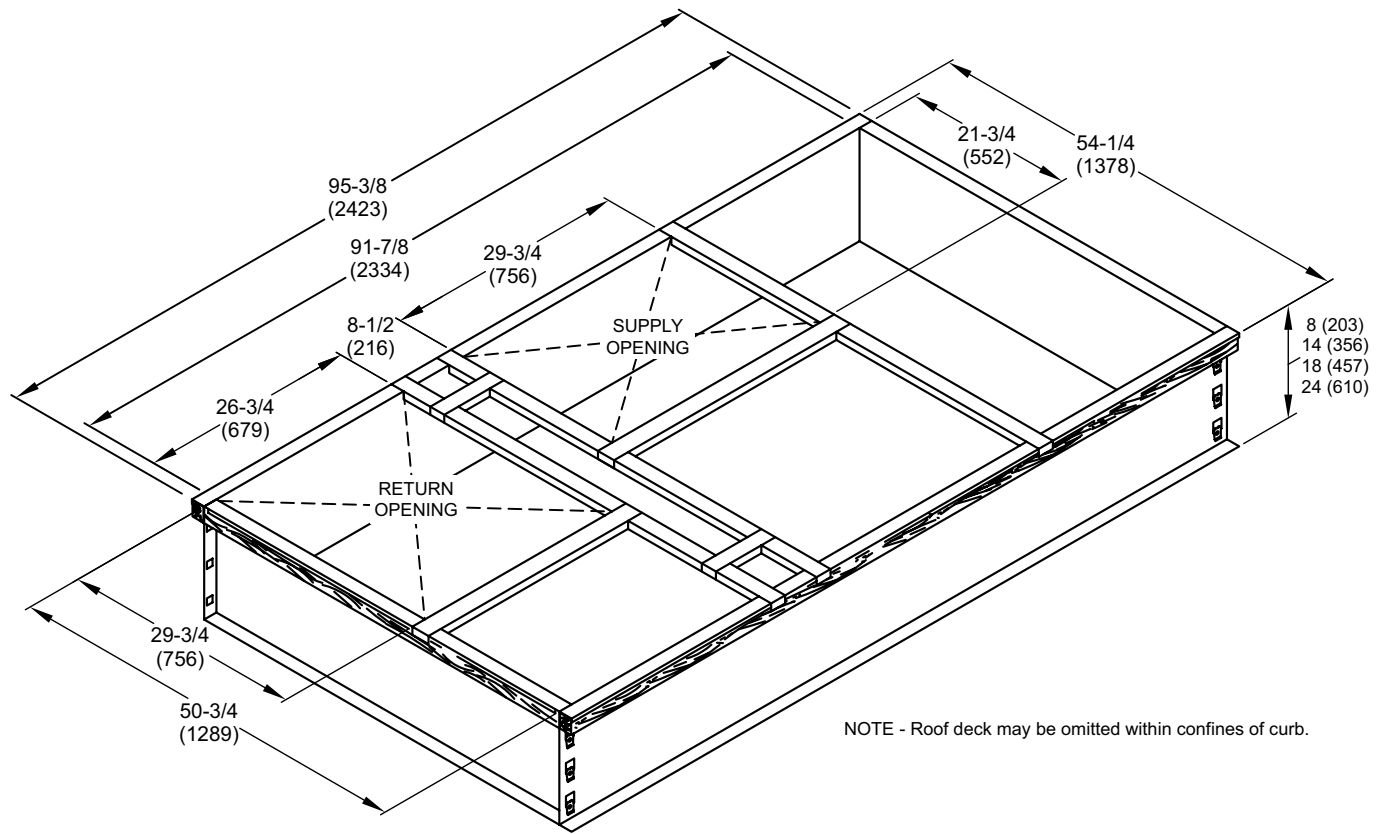

NOTE - Roof deck may be omitted within confines of curb.

TYPICAL FLASHING DETAIL FOR ROOF CURB

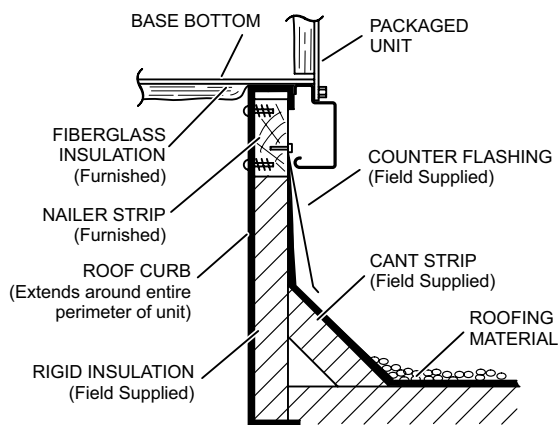

DETAIL ROOF CURB

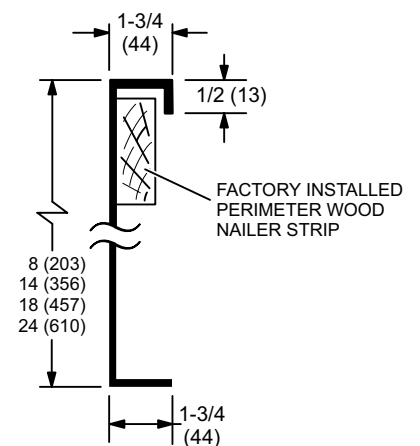

ADJUSTABLE PITCH CURBS - DOUBLE DUCT OPENING

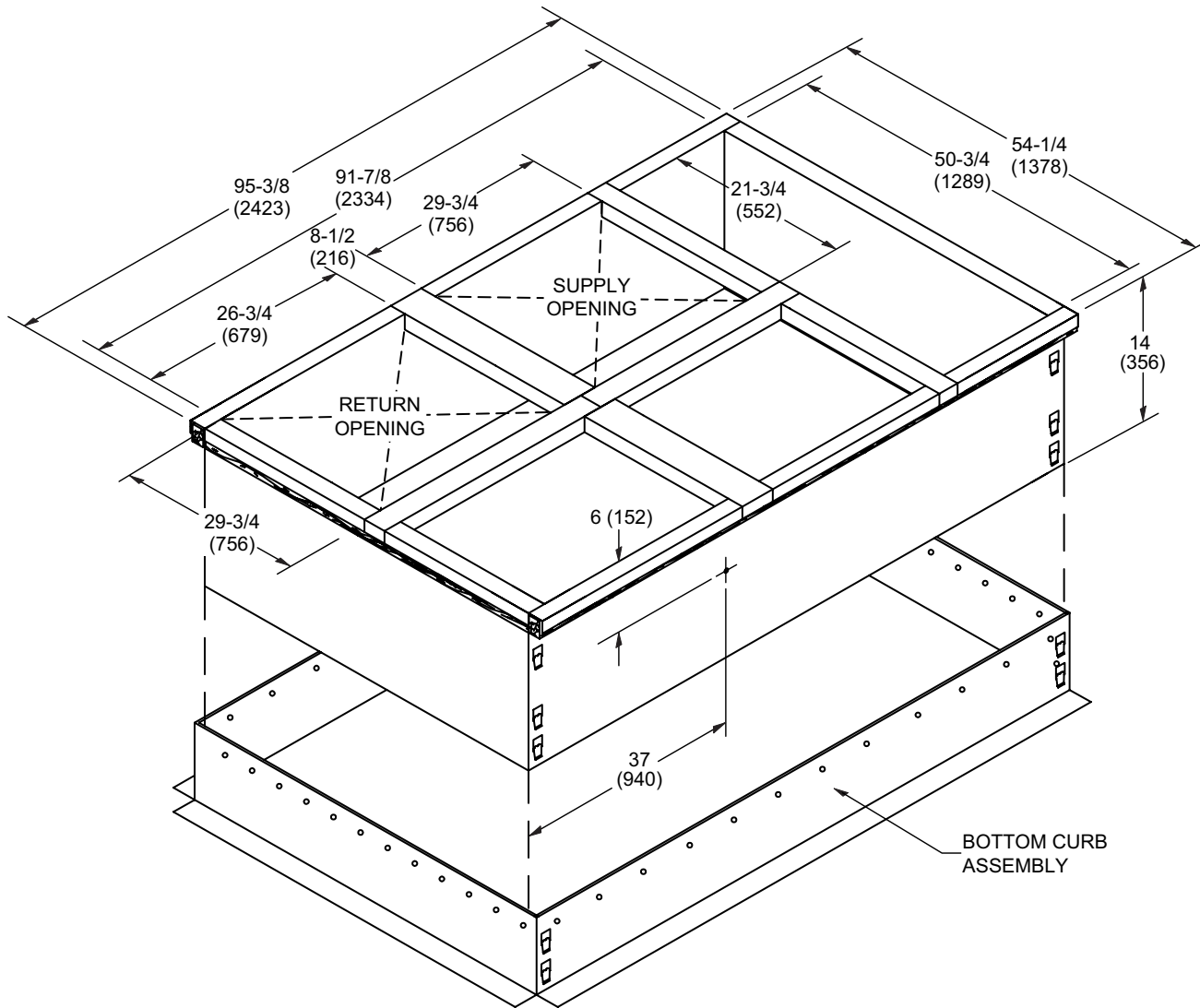

NOTE - Maximum slope pitch is 3/4 in. per 1 foot (19 mm per 305 mm) in any one direction.

TYPICAL FLASHING DETAIL FOR ROOF CURB

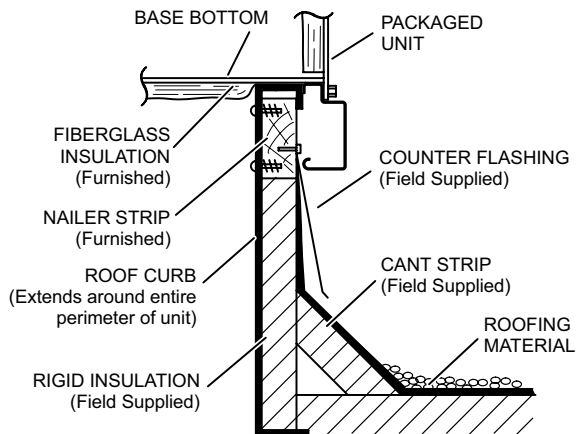

DETAIL ROOF CURB

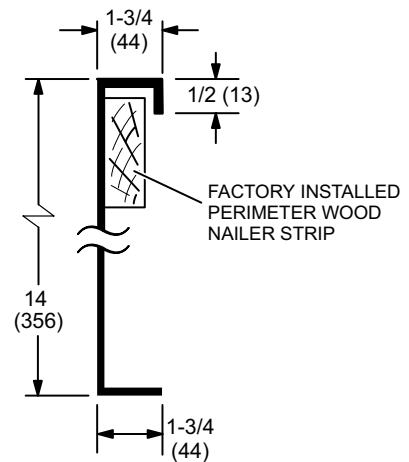

ROOF CURBS WITH SUPPLY & RETURN AIR TRANSITIONS FOR CEILING DIFFUSERS

C1DIFF30B-1 ROUND TRANSITIONS
(for 078 and 092 models)

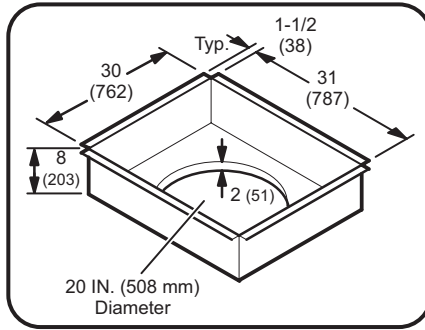

C1DIFF31B-1 RECTANGULAR TRANSITIONS
(for 102, 122 and 150 models)

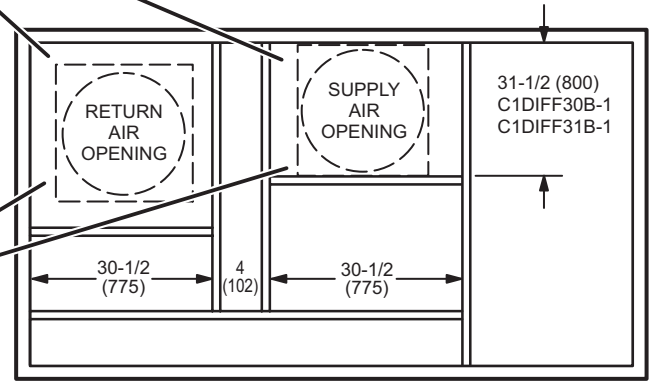
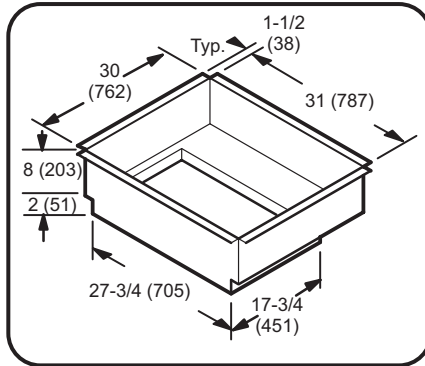

TOP VIEW

COMBINATION CEILING SUPPLY AND RETURN DIFFUSERS

STEP-DOWN CEILING DIFFUSER

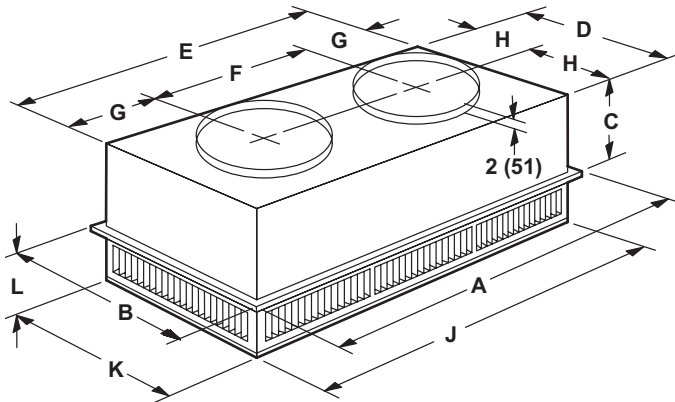

FLUSH CEILING DIFFUSER

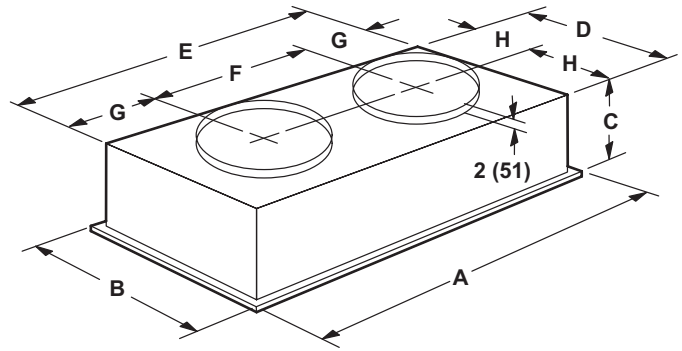

Model Number		RTD11-95S
A	in.	47-5/8
	mm	1159
B	in.	29-5/8
	mm	752
C	in.	14-3/8
	mm	365
D	in.	27-1/2
	mm	699
E	in.	45-1/2
	mm	1158
F	in.	22-1/2
	mm	572
G	in.	11-1/2
	mm	292
H	in.	13-3/4
	mm	349
J	in.	45-1/2
	mm	1156
K	in.	27-1/2
	mm	699
L	in.	8-1/8
	mm	206
Duct Size	in.	20 round
	mm	508 round

Model Number		FD11-95S
A	in.	47-5/8
	mm	1159
B	in.	29-5/8
	mm	752
C	in.	16-5/8
	mm	422
D	in.	27
	mm	686
E	in.	45
	mm	1143
F	in.	22-1/2
	mm	572
G	in.	11-1/4
	mm	286
H	in.	13-1/2
	mm	343
Duct Size	in.	20 round
	mm	508 round

COMBINATION CEILING SUPPLY AND RETURN DIFFUSERS

STEP-DOWN CEILING DIFFUSER

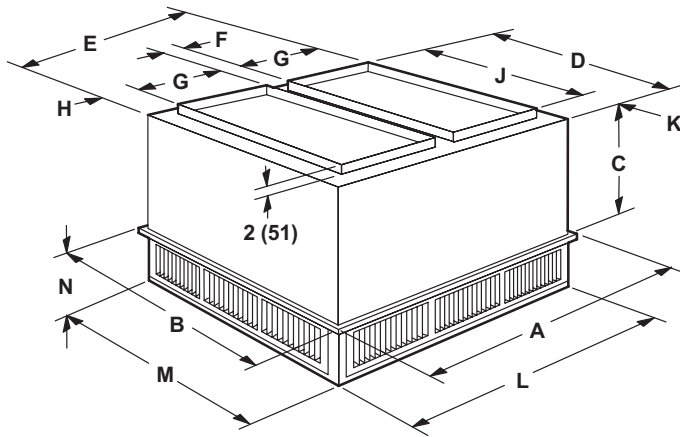

FLUSH CEILING DIFFUSER

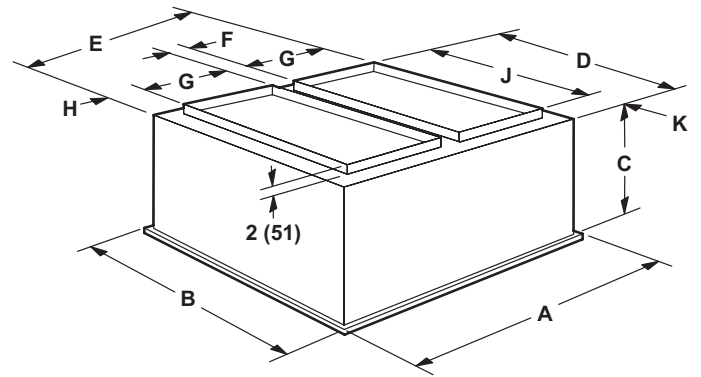

Model Number		RTD11-135S
A	in.	47-5/8
	mm	1210
B	in.	35-5/8
	mm	905
C	in.	20-5/8
	mm	524
D	in.	33-1/2
	mm	851
E	in.	45-1/2
	mm	1156
F	in.	4-1/2
	mm	114
G	in.	18
	mm	457
H	in.	2-1/2
	mm	64
J	in.	28
	mm	711
K	in.	2-3/4
	mm	70
L	in.	45-1/2
	mm	1156
M	in.	33-1/2
	mm	851
N	in.	9-1/8
	mm	232
Duct Size	in.	18 x 28
	mm	457 x 711

Model Number		FD11-135S
A	in.	47-5/8
	mm	1210
B	in.	35-5/8
	mm	905
C	in.	23-1/4
	mm	591
D	in.	33
	mm	838
E	in.	45
	mm	1143
F	in.	4-1/2
	mm	114
G	in.	18
	mm	457
H	in.	2-1/4
	mm	57
J	in.	28
	mm	711
K	in.	2-1/2
	mm	64
Duct Size	in.	18 x 28
	mm	457 x 711

REVISIONS

Sections	Description of Change
Specifications	Updated Gas Heating Performance and Thermal Efficiency values.
High Altitude Derate	Updated Gas Manifold Pressure and Input Rate values.



Visit us at www.Lennox.com

For the latest technical information, www.LennoxCommercial.com

Contact us at 1-800-4-LENNOX

NOTE - Due to Lennox' ongoing commitment to quality, Specifications, Ratings and Dimensions subject to change without notice and without incurring liability. Improper installation, adjustment, alteration, service or maintenance can cause property damage or personal injury. Installation and service must be performed by a qualified installer and servicing agency.

©2023 Lennox Industries, Inc.