



SUBMITTAL DATA – Multi-Position AHU

MPC024S4S-1P – MMA024SM4-1P

SINGLE ZONE MINI-SPLIT HEAT PUMP

Job: _____
Location: _____
Schedule No.: _____
System Designation: _____

Engineer: _____
Architect: _____
Date: _____
For: Reference Approval Review Construction

FEATURES

Outdoor Unit: MPC024S4S-1P



- DC Inverter Control
- Compressor Overcurrent Protection
- Base Pan Heater
- Defrost Control

Indoor Unit: MMA024SM4-1P



- Constant torque blower motor
- Multi-position cabinet (upflow, downflow, horizontal)
- Completely insulated with foil faced fiberglass insulation
- Low leakage (less than 2%) cabinet

PIPING

Line Set and Elevation Guidelines

Maximum Line Set Length ft. (m)	164 (50)
Maximum Elevation - Outdoor Unit Below/Above Indoor Unit ft. (m)	82 (25)
Liquid Line Set Diameter (in.)	3/8
Gas Line Set Diameter (in.)	5/8
Pre-Charged (ft.)	25
Additional Charge of Refrigerant (oz/ft.)	0.32

PRODUCT WARRANTY

Compressor – Twelve year limited warranty*
 All other covered components - Twelve year limited warranty*
 *Product registration required

OPTIONAL ACCESSORIES

Hail Guards (M9GARD22Q-1)
 Programmable Controller (M0STAT120N-1)
 M30 Smart Wi-Fi Thermostat (M0STAT64Q-2)



NOTE – Due to Lennox' ongoing commitment to quality, Specifications, Ratings, and Dimensions are subject to change without notice and without incurring liability. Improper installation, adjustment, alteration, service or maintenance can cause property damage or personal injury. Installation and service must be performed by a qualified installer and servicing agency.



SUBMITTAL DATA – Multi-Position AHU

MPC024S4S-1P – MMA024SM4-1P

SINGLE ZONE MINI-SPLIT HEAT PUMP

OUTDOOR SPECIFICATIONS

PERFORMANCE	
Cooling Capacity (Min/Max) (Btu/h) ¹	24,000 (6,100/28,200)
EER2	12.3
SEER2	19.0
Heating Capacity (Min/Max) (Btu/h) ¹	24,600 (11,700/33,000)
HSPF2	11.0
Outdoor Fan Total Air Volume (CFM)	2,235
Ambient Temperature Operating Range	
Cooling	-13°F - 122°F
Heating	-13°F - 86°F

ELECTRICAL DATA	
Power Supply (V/Hz/Φ)	208-230/60/1
Minimum Circuit Ampacity (A)	23
Maximum Overcurrent Protection (A)	30
Outdoor Fan Motor RLA (A)	0.60
Compressor RLA (A)	15
No. of Compressors	1

GENERAL DATA	
Connection Ratio (%)	100%
Max. # of Indoor Units	1 unit
Sound Data (dBA) - Cooling/Heating	60/60
Refrigerant type	R-410A
Factory refrigerant charge	5 lbs. 3 oz.

DIMENSIONS		
Unit Dimensions (in)	Height	31-7/8
	Width	40-1/2
	Depth	18
Shipping Weight (lb)	135	
Net Weight (lb)	125	

NOTES

1. Cooling and Heating Capacity data is rated at the following conditions:
 Cooling: 80°FDB / 67°FWB Indoor, 95°FDB Outdoor
 Heating: 70°FDB Indoor, 47°FDB / 43°FWB Outdoor

OUTDOOR DIMENSIONAL DRAWINGS - INCHES (MM)

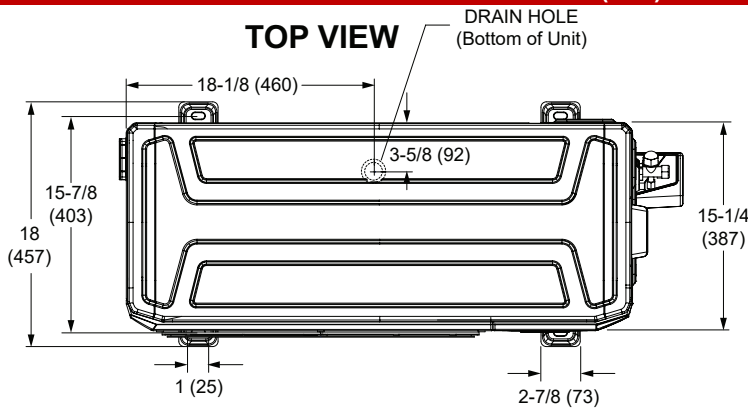

FRONT VIEW

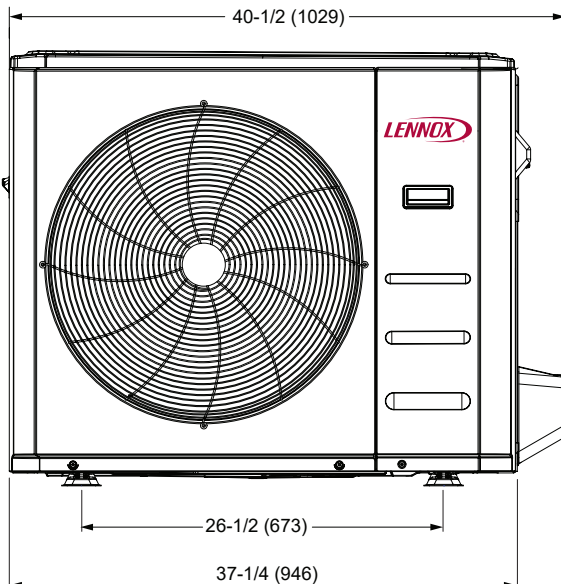

SIDE VIEW

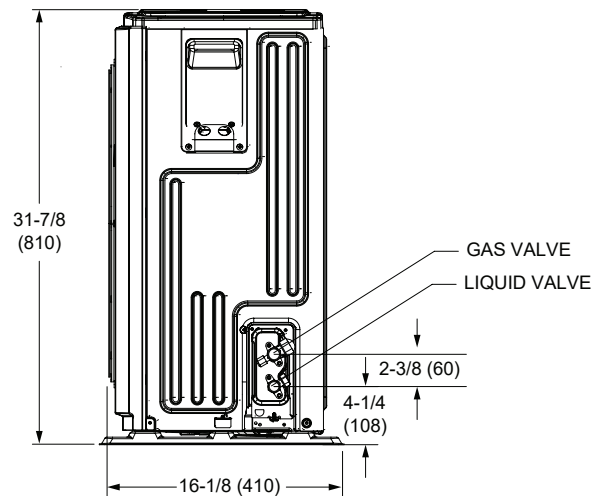

NOTE – Due to Lennox' ongoing commitment to quality, Specifications, Ratings, and Dimensions are subject to change without notice and without incurring liability. Improper installation, adjustment, alteration, service or maintenance can cause property damage or personal injury. Installation and service must be performed by a qualified installer and servicing agency.
 496007(202306) ©2023 Lennox Industries, Inc.



SUBMITTAL DATA – Multi-Position AHU

MPC024S4S-1P – MMA024SM4-1P

SINGLE ZONE MINI-SPLIT HEAT PUMP

INDOOR SPECIFICATIONS

PERFORMANCE

Airflow (CFM)	High	759
	Medium	694
	Low	629
External Static Pressure (in. w.g.)		0 - 0.80
Sound Pressure (dBA)	High	41
	Medium	39
	Low	38

ELECTRICAL DATA

Power Supply (V/Hz/Φ)	208/230V 60Hz 1Ph
Maximum Overcurrent Protection (MOCP)	15
Minimum Circuit Ampacity (MCA)	4

DIMENSIONS

Unit Dimensions (in)	Height	45
	Width	17-1/2
	Depth	21

Shipping Weight (lb)	128
----------------------	-----

PIPING

Liquid/Gas O.D. Flare (in.)	3/8 , 5/8
Drain Connection O.D. (in.)	3/4

FILTERS

Size of filter - in.	16 X 20 X 1
Optional Electric Heat	Electric Heat - Please see EHB
Electric Heat Net Weight - lbs.	13

INDOOR DIMENSIONAL DRAWINGS - INCHES (MM)

Model No.	018 / 024		036 / 048		060	
	in.	mm	in.	mm	in.	mm
A (Height)	45	1143	49	1245	53	1346
B Width)	17-1/2	445	21-1/4	540	24-1/2	622
C	15-5/8	397	19-1/8	486	22-5/8	575
D	15-1/8	384	18-5/8	473	22-1/8	562
E	1-1/4	32	1-1/4	32	1-1/8	28
F	1-1/2	38	1-5/8	41	1-5/8	41
G	5/8	16	5/8	16	3/4	19

NOTE – Due to Lennox' ongoing commitment to quality, Specifications, Ratings, and Dimensions are subject to change without notice and without incurring liability. Improper installation, adjustment, alteration, service or maintenance can cause property damage or personal injury. Installation and service must be performed by a qualified installer and servicing agency.



SUBMITTAL DATA – Multi-Position AHU

MPC024S4S-1P – MMA024SM4-1P

SINGLE ZONE MINI-SPLIT HEAT PUMP

INDOOR DIMENSIONAL DRAWINGS - INCHES (MM)

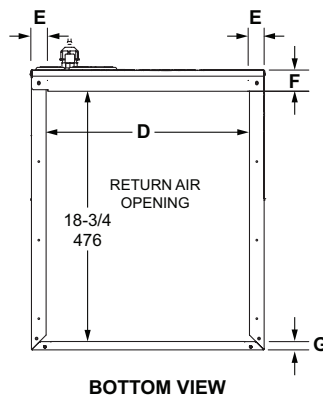
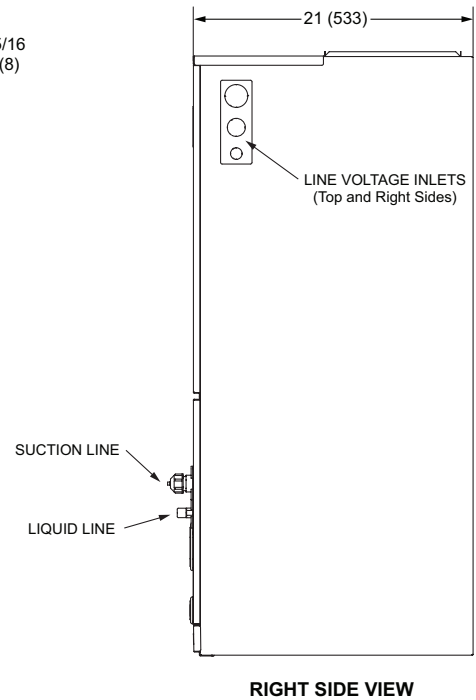
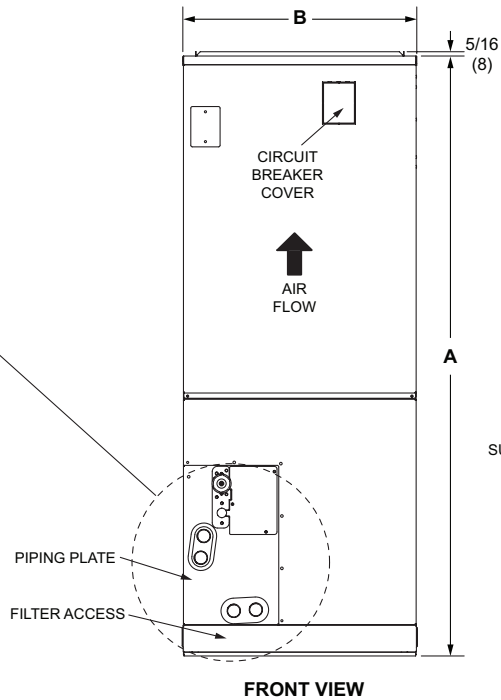
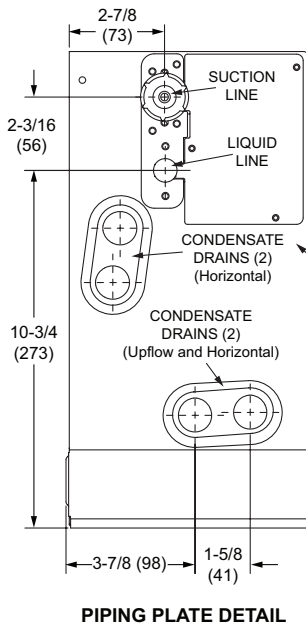
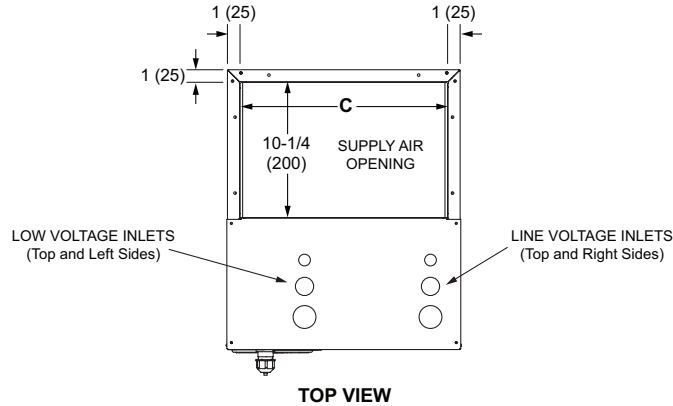

NOTE – Due to Lennox' ongoing commitment to quality, Specifications, Ratings, and Dimensions are subject to change without notice and without incurring liability. Improper installation, adjustment, alteration, service or maintenance can cause property damage or personal injury. Installation and service must be performed by a qualified installer and servicing agency.
496007(202306) ©2023 Lennox Industries, Inc.