

506295-01
4/2021
Supersedes 11/2009

HORIZONTAL DISCHARGE KIT

INSTALLATION INSTRUCTIONS FOR HORIZONTAL DISCHARGE KIT (51W25; 603374-01) USED WITH LG/LC/KG/KC/KH 092-150 UNITS

Shipping and Packing List

Package 1 of 1 contains:

- 1- Supply air cover (left)
- 1- Supply air cover (right)
- 1- Bag assembly containing:
16 Screws
- 1- Return air cover
- 1- Return air support bracket
- 1- Return air duct panel

Application

The horizontal discharge kit is used on LG/LC/KG/KC/KH 092-150 units.

Installation

- 1- Disconnect power to unit at unit disconnect.
- 2- Remove rear unit panels. See figure 1.
- 3- Install the supply air covers over downflow supply air opening. Center flanges will overlap and rear flanges fit underneath unit base pan. Secure cover in place with 4 screws provided. See figures 2 and 3.

⚠ WARNING

Improper installation, adjustment, alteration, service or maintenance can cause property damage, personal injury or loss of life. Installation and service must be performed by a qualified installer, service agency or the gas supplier

⚠ CAUTION

Danger of sharp metallic edges. Can cause injury. Take care when servicing unit to avoid accidental contact with sharp edges.

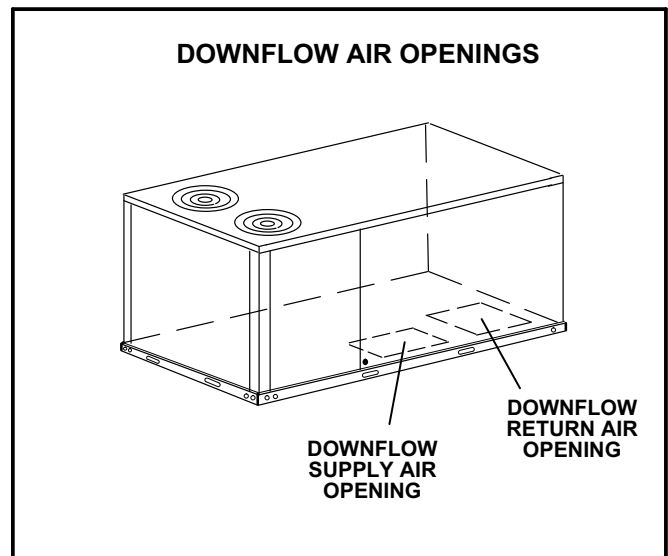
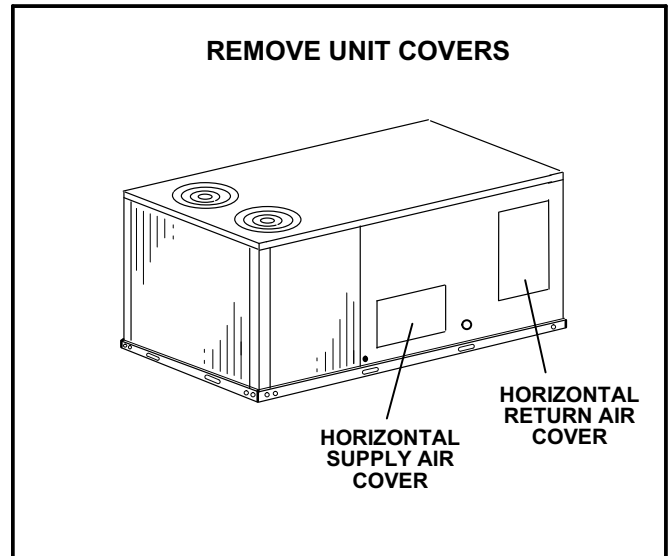

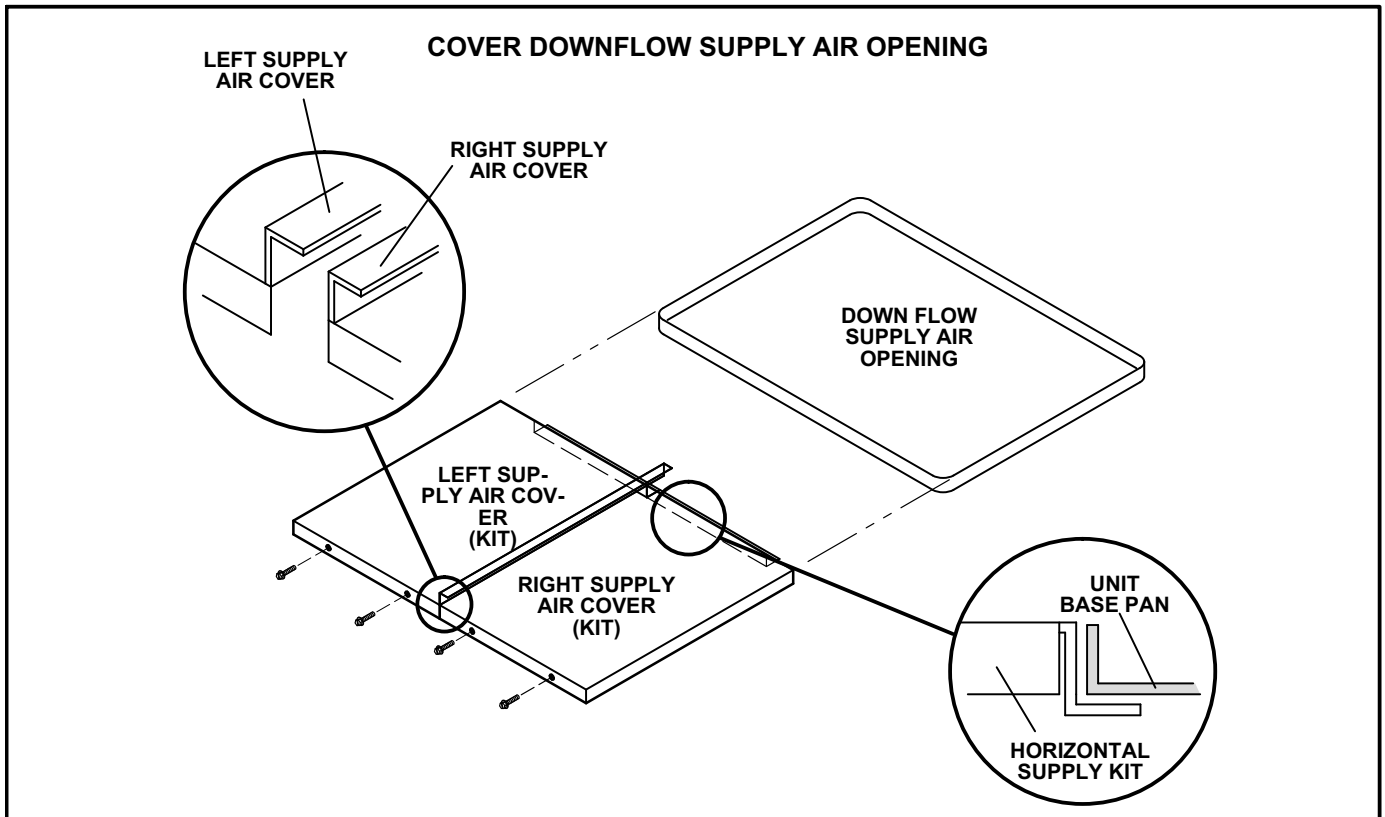

FIGURE 3

- 4- Remove the end panel and install the return air support bracket. See figures 4 and 5. Insert one end of panel onto return air opening crown and rotate to fit the other end in opening.

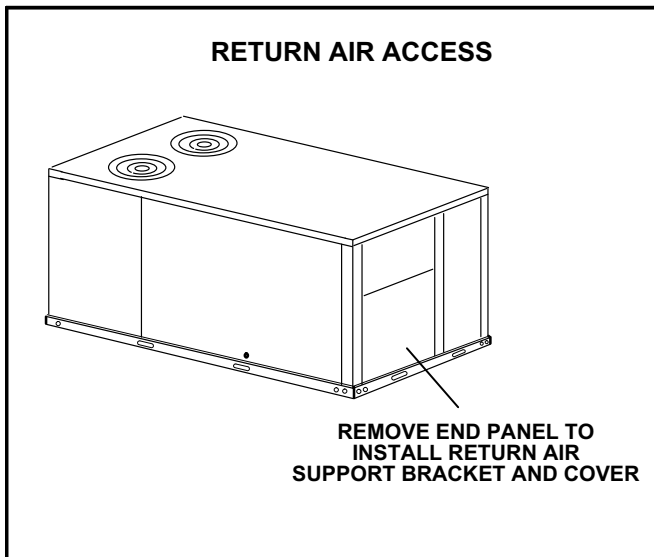

FIGURE 4

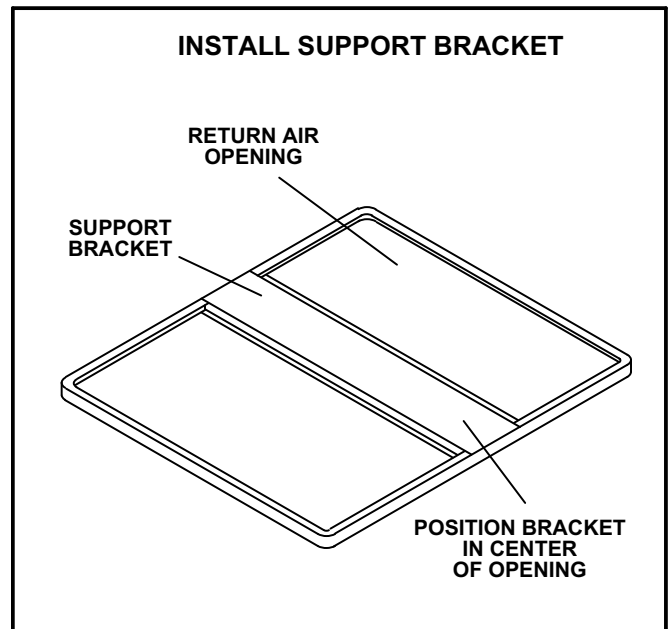

FIGURE 5

- 5- Position the return air panel over the return air opening with the offset edge toward the unit. Fit the offset edge under the return air opening crown. See figure 6.
- 6- Secure return air panel to the support bracket using screws provided. See figure 7.
- 7- Secure the return air cover to the return air opening crown with screws provided. Two screws are positioned on top of the cover and three screws are positioned on the front edge.

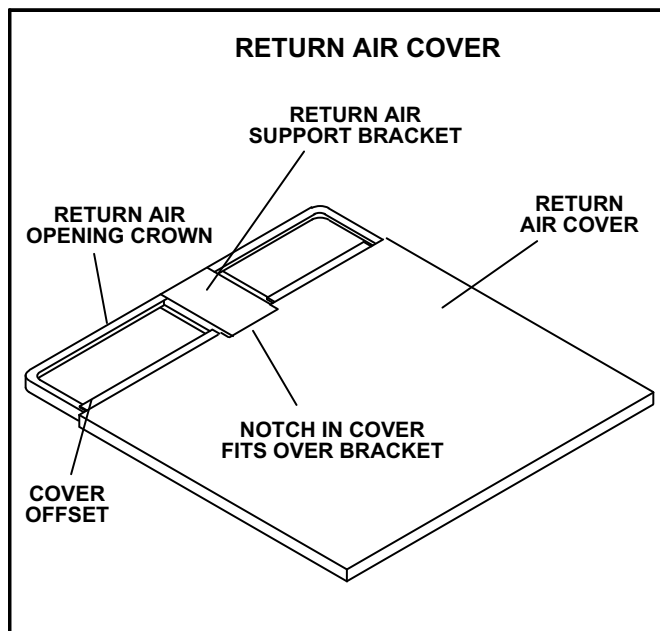

FIGURE 6

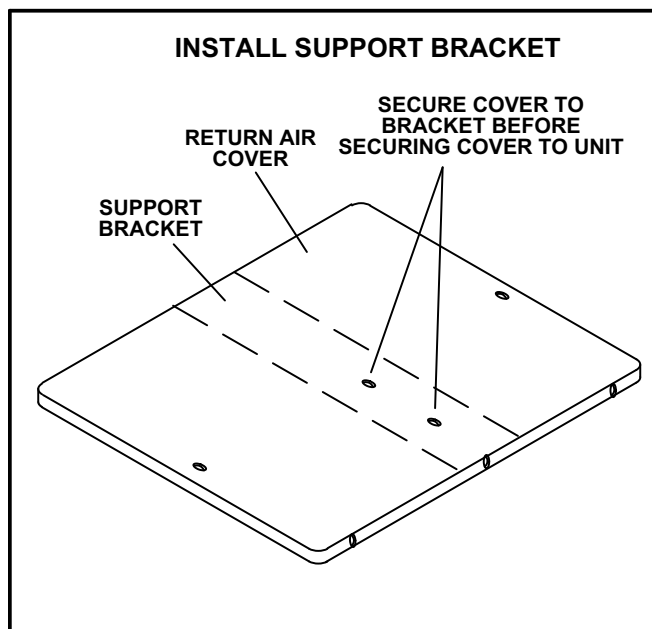

FIGURE 7

- 8- When no optional outdoor air accessory (economizer, outdoor air damper, etc.) is installed, replace the unit end panel. Discard the return air duct panel provided in kit.
- 9- When an outdoor air accessory is installed, secure the return air duct on the end of the unit and replace the rear horizontal return air cover. See figure 1.

Note - Outdoor air hoods, packaged with outdoor air accessory, are installed above the return air duct panel.