

NIDEC GEN 2 TO GEN 3 MOTOR CONVERSION

508423-01

11/2023

INSTALLATION INSTRUCTIONS FOR NIDEC INDOOR BLOWER MOTOR AND CONTROL MODULE REPLACEMENT USED ON ON CBA25UHV AND EQUIVALENT UNITS

⚠ WARNING

Improper installation, adjustment, alteration, service or maintenance can cause property damage, personal injury or loss of life. Installation and service must be performed by a licensed professional HVAC installer or equivalent, service agency, or the gas supplier.

⚠ CAUTION

As with any mechanical equipment, contact with sharp sheet metal edges can result in personal injury. Take care while handling this equipment and wear gloves and protective clothing.

⚠ WARNING



Electric Shock Hazard! – Disconnect all power supplies before servicing.

Replace all parts and panels before operating.

Failure to do so can result in death or electrical shock.

⚠ WARNING

Electric Shock Hazard.

Can cause injury or death.

Foil-faced insulation has conductive characteristics similar to metal. Be sure there are no electrical connections within 1/2" of the insulation. If the foil-faced insulation comes in contact with electrical voltage, the foil could provide a path for current to pass through to the outer metal cabinet. While the current produced may not be enough to trip existing electrical safety devices (e.g. fuses or circuit breakers), the current can be enough to cause an electric shock hazard that could cause personal injury or death.

NOTE – Due to the obsolescence of the Nidec Generation 2 motor platform, repair of older product that utilized this motor requires the replacement of the motor and its controls. Dimensional differences in the new Generation 3 motor require the 16X4 16-pin black programmed motor control box to be mounted on the blower housing. This kit provides the necessary mounting plate, harness and hardware to mount the 16X4 16-pin black programmed motor control box. A new Generation 3 motor with control must be ordered along with a 16X4 16-pin black programmed motor control box listed for the specific air handler in Table 1.

Shipping and Packing List

Package 1 of 1 contains:

- 1 - Installation instructions
- 2 - 16X4 programmed motor control
- 3 - Control-box-to-motor harness
- 4 - Motor mounting plate
- 5 - Mounting hardware

Application

Use the kit specified in the following table to replace the motor or control module in CBA25UHV and equivalent units.

Motor Removal and Replacement

- 1 - Disconnect all electrical power to unit. Wait at least five minutes before beginning service procedures. This will allow internal capacitors to fully discharge, avoiding possible electrical shock.
- 2 - Remove the blower access panel.
- 3 - Unplug the 5-pin (J48) connector motor power harness from the motor control module and the 16-pin (J49) connector harness from the 16X4 black programmed motor control box located on the end of the motor.
- 4 - Remove housing from unit.
- 5 - Remove motor assembly from housing.
- 6 - Replace motor with Gen 3 motor assembly.
- 7 - Set motor band spacing per figure 2.
- 8 - Install new motor in housing.
- 9 - Install blower assembly.

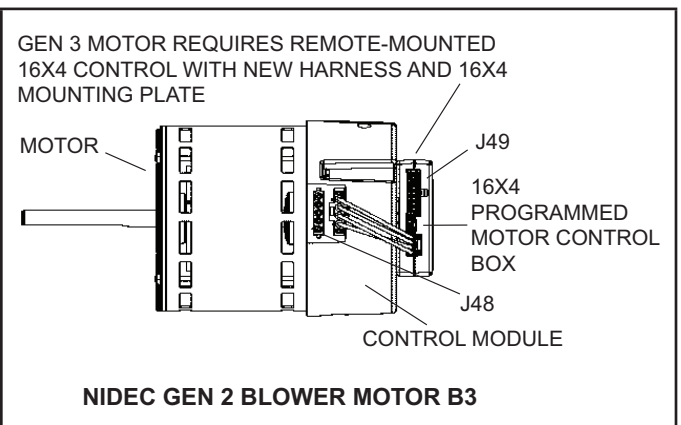

FIGURE 1

NOTE – Two kits are required to replace Gen 2 motors. All replacement 16-pin control modules look alike. Make sure the part number is the correct one for the unit.

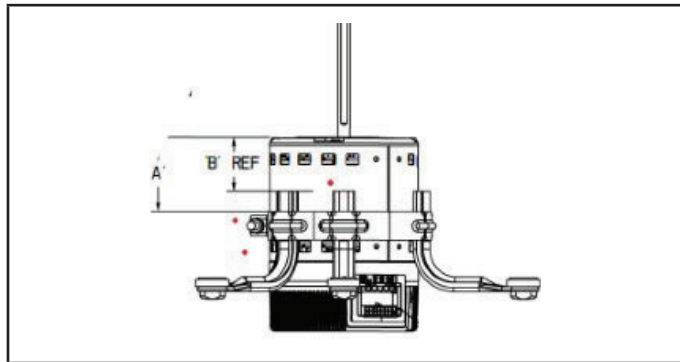

FIGURE 2

Unit	“A”	Unit	“A”
18	1.05	42	1.88
24	1.05	48	1.88
30	1.05	60	1.88
36	1.05	--	--

⚠ IMPORTANT

Generation 2 motors and controls are not compatible with the new Generation 3 motors. All Generation 2 components, motor, control and 16-pin box must be replaced.

- 1 - Install the motor control mounting plate onto blower housing using existing clearance holes on blower wrapper using item 4 (see figure 3). Install mounting plate so that existing 16-pin harness will reach the 16X4 16-pin black programmed motor control box
- 2 - Install 16-pin box with item 5 mounting hardware. See Table 1 for correct part number.
- 3 - Plug the 5-pin connector (J48) on the existing motor power harness into the jack on the motor control module.
- 4 - Install new harness (item 3) into the 16x4 black programmed motor control module and the 4-pin connector on the motor module located on the motor.
- 5 - Reconnect the existing 16-pin harness plug (J49) into the new 16X4 16-pin black programmed motor control box located on the blower housing.
- 6 - Restore power to unit.

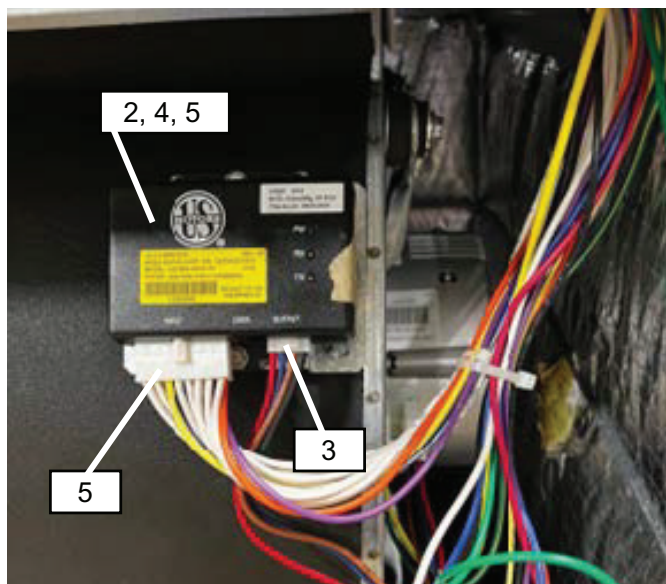
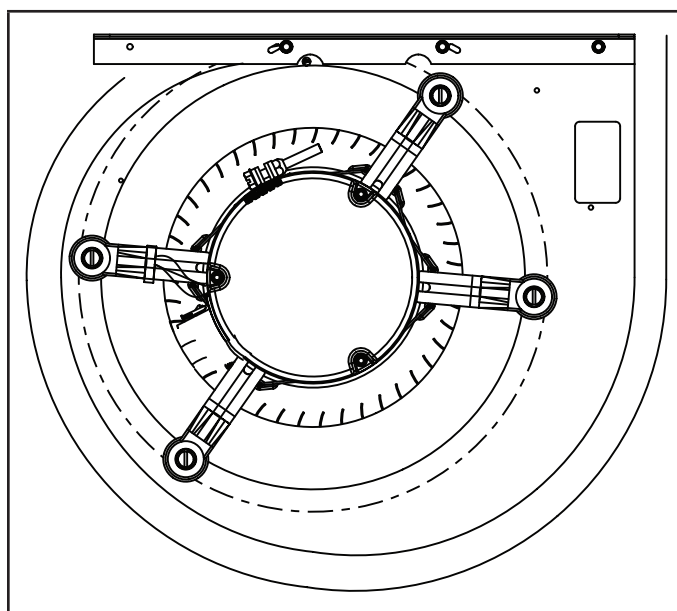

FIGURE 3

NOTE – Orient connections towards return opening.



NOTE – Orient motor connections as shown.

TABLE 1

Repair Part for Dash Numbers Built with Gen 2 16 Pin Nidec Motors									
Old Part Number	Model Number (used to convert all dash number)	Allied Model Number	Allied Model Number	Motor HP	Gen 3 Motor Part Number (16X4 16-Pin Programmed Motor Control Box is not - Included)	Gen 3 Motor With Motor Control Cat (16X4 16-Pin Programmed Motor Control Box is not Included)	Coversions kit with 16X4 Programmed Control box, harness mounting plate and hardware	Cat #	
104758-19	CBA/CBX25UHV-018	BCE5V18MA4X/ BCE5V18MA4X/NA M18V1TA 4	BCE3M18V00NA4X/	1/2	107598-01	24Y86	626023-02	26146	
104758-20	CBA/CBX25UHV-024	BCE5V24MA4X/NA M18V1TA 4/HCG24V1P BCE530MA4X/ BCE530MA4X/NA M30V1TA4/ HC30V 1P	BCE3M24V00NA4X/ HCG24V1M	1/2	107598-01	24Y86	626023-03	26154	
104758-21	CBA/CBX25UHV-030	BCE5V36MA4X/ BCE5V36MA4X/NA M36V1TA 4/HCG36V1P	BCE3M30V00NA4X/	1/2	107598-01	24Y86	626023-04	26156	
104758-22	CBA/CBX25UHV-036	BCE5V42MA4X/ BCE5V42MA4X/NA M42V1TA 4/HCG42V1P	BCE3M36V00NA4X/ HCG36V1M	1/2	107598-01	24Y86	626023-05	26157	
104758-23	CBA25UHV-042	BCE5V48MA4X/ BCE5V48MA4X/NA M48V1TA 4/HCG48V1P	N/A	1	107598-03	24Y89	626023-06	26158	
104758-24	CBA25UHV-048	BCE5V60MA4X/ BCE5V60MA4X/NA M60V1TA 4/HCG60V1P	N/A	1	107598-03	24Y89	626023-07	26159	
104758-25	CBA25UHV-060	N/A	N/A	1	107598-03	24Y89	626023-08	26160	
104758-05	CBX25UHV-042	N/A	BCE3M42V00NA4X/ HCG42V1M	3/4	107598-02	24Y88	626023-09	26161	
104758-06	CBX25UHV-048	N/A	BCE3M48V00NA4X/ HCG48V1M	1	107598-03	24Y89	626023-10	26162	
104758-07	CBX25UHV-060	N/A	BCE3M60V00NA4X/ HCG60V1M	1	107598-03	24Y89	626023-11	26163	