

ROOFTOP UNIT KITS AND ACCESSORIES

508121-01
5/2022
Supersedes 2/2022

BLOWER MOTOR & IMPELLER REPLACEMENT KIT

INSTALLATION INSTRUCTIONS FOR BLOWER MOTOR & IMPELLER REPLACEMENT KIT USED WITH SGH/SCH036 & 060 AND LG/LC/LH/LD 024-074 UNITS

Shipping and Packing List

Package 1 of 1 contains:

- 1- Blower motor and impeller assembly
- 1- Bag assembly containing:
 - 6-Bolts
 - 1-Adapter control harness

⚠ WARNING

Improper installation, adjustment, alteration, service or maintenance can cause property damage, personal injury or loss of life. Installation and service must be performed by a licensed professional HVAC installer or equivalent, service agency, or the gas supplier

Application

See table 1 for usage.

Kit Adapter Control Harness -

Use the kit harness and make the 9-pin control harness connection in the blower compartment on older model SGH/SCH units. Discard the kit harness when the control connector (J335 or Modbus harness) is located in the blower compartment. See figure 3.

TABLE 1

	Unit	Voltage
21P21 - 621157-03	SGH/SCH036 & 060 LG/LC/LH/LD 024-074	Y
21P22 - 621157-04	SGH/SCH036 - 060 LG/LC/LH/LD 024-074	G, J

Installation

- 1- Disconnect electrical power to unit. Wait five minutes before continuing service procedures to avoid electrical shock. This will allow internal capacitors time to fully discharge.
- 2- Open access panels as shown in figure 1 or 2.

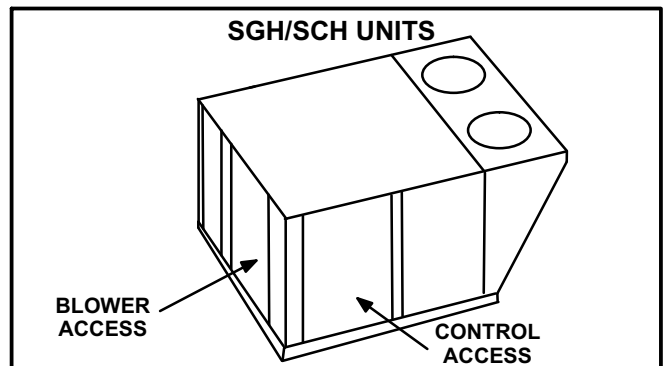

FIGURE 1

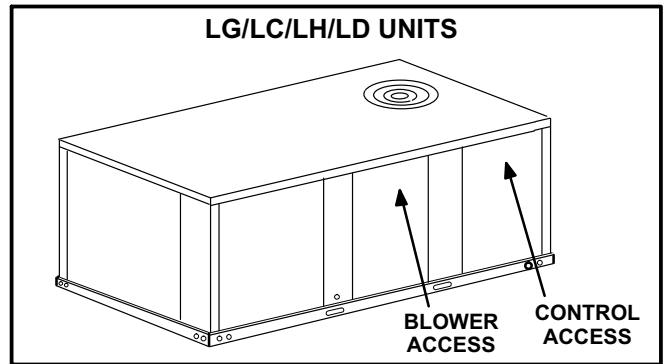

FIGURE 2

CONTROL HARNESS CONNECTOR LOCATION - SGH/SCH UNITS

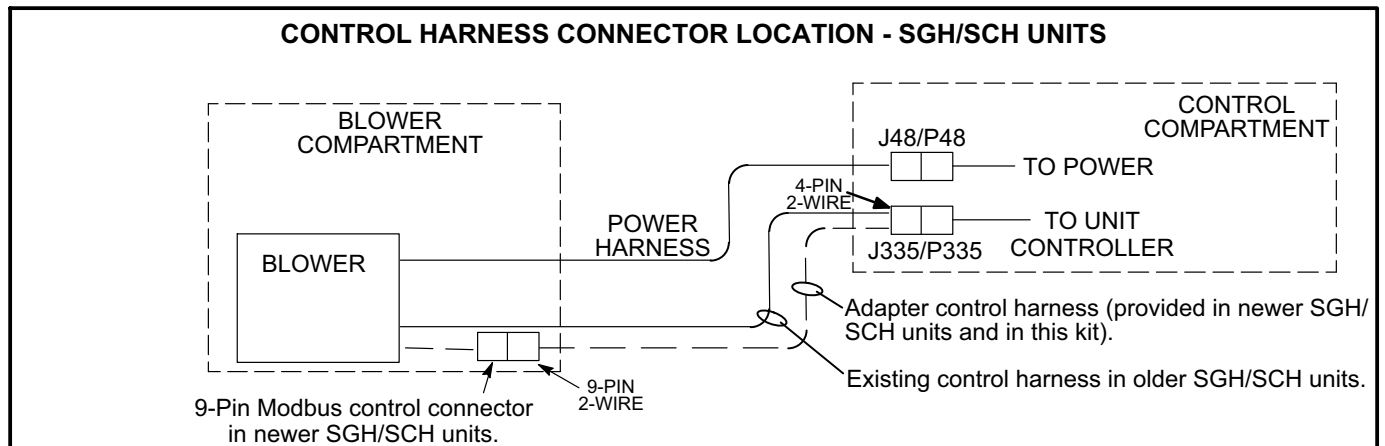

FIGURE 3



⚠ CAUTION

As with any mechanical equipment, contact with sharp sheet metal edges can result in personal injury. Take care while handling this equipment and wear gloves and protective clothing.

3- SGH/SCH Units -

Disconnect J48 from P48 in the controls area and unscrew the GND terminal from the control panel. See figure 4.

LG/LC/LH/LD Units -

Disconnect J48 from P48 in the blower area and unscrew the GND terminal from the blower deck.

4- Older SGH/SCH Units -

Disconnect J335 from P335 control connectors located in the control box.

Newer SGH/SCH & LG/LC/LH/LD Units -

Disconnect the Modbus 9-pin blower control plug located in the blower area.

5- Cut wire ties where necessary and pull power and/or control harnesses from control area into blower section.

Note - The top panel may need to be raised to pull the control harness through the convoluted tubing in between the blower and controls section.

6- Remove four screws securing blower assembly to unit. See figure 5.

7- If unit was equipped with a blower proving switch, remove switch from blower housing.

8- LGM/LCM Units -

When present, remove PT6 pressure transducer

bracket and silicone tubing from housing. See figure 5. If needed, remove the inlet ring to disconnect the tubing from the inlet ring barb. See figure 7. Disconnect the pressure transducer wire connector.

9- Use the handle on the blower assembly to slide the assembly out of unit.

10- Turn the blower assembly upside down. See figure 6.

11- Remove the inlet grill, inlet ring, and the side of the housing shown in figure 7.

12- Remove the motor / impeller secured to the housing. See figures 6 and 7.

13- Install replacement motor / impeller on blower housing in the same manner the existing motor / impeller was removed. Secure with 6 bolts provided in this kit. Tighten to 21.7 ft.-lbs.

14- If unit was equipped with a blower proving switch, re-attach the proving switch to the housing in the same manner it was removed.

15- LGM/LCM Units -

Attach the pressure transducer bracket, wire connector, and silicone tubing to the housing in reverse order of removal.

16- Replace the blower housing side, inlet ring, and inlet grill which was previously disassembled. Tighten inlet ring screws to 10.8 ft.-lbs. Tighten inlet grill screws to 3.7 ft.-lbs.

17- Install blower assembly flanges into rails on the blower deck in the same manner it was removed. Secure into place using four screws shown in figure 5.

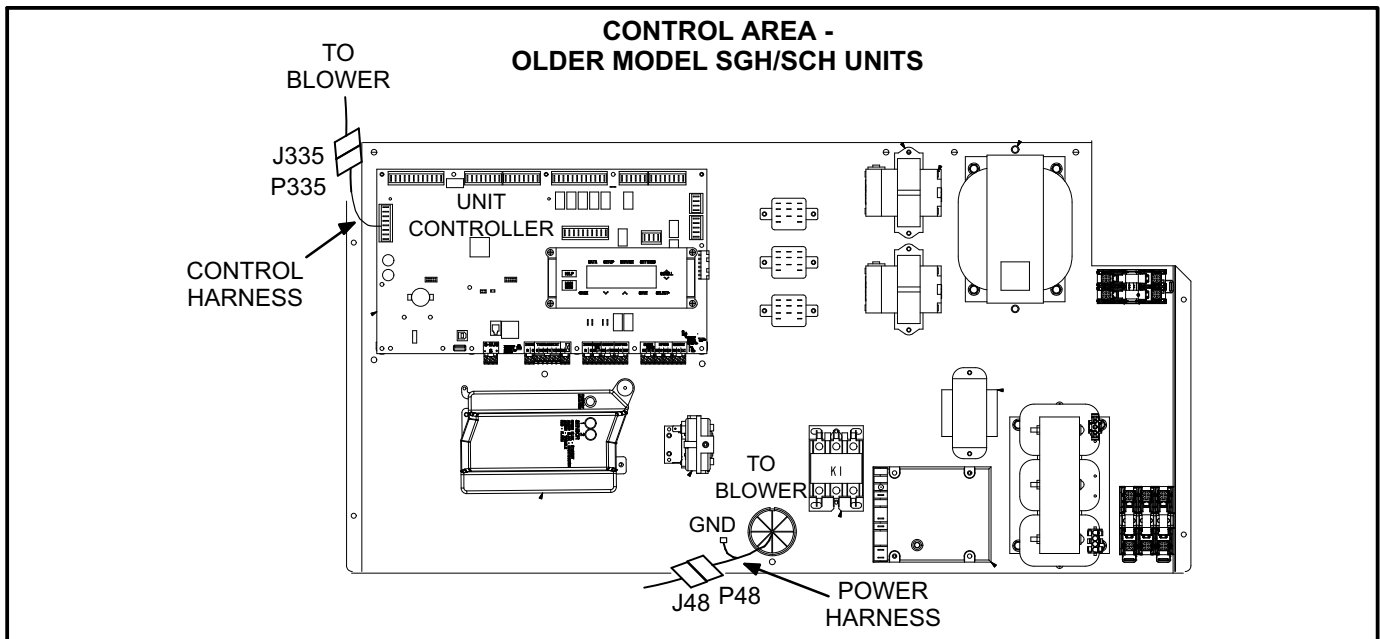

FIGURE 4

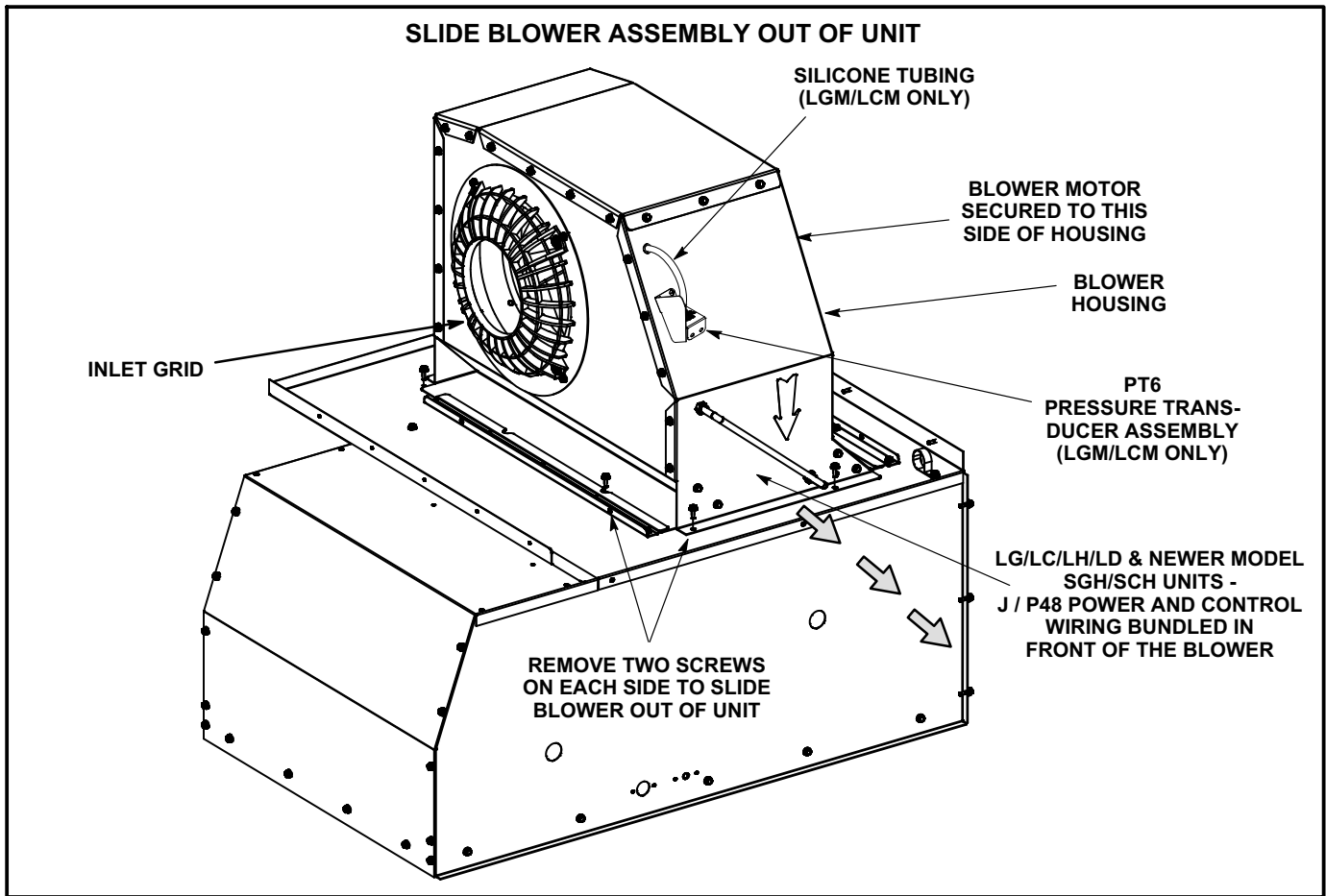

FIGURE 5

18- Uncoil P48 power harness and Modbus control harnesses secured to replacement blower motor / impeller.

19- *SGH/SCH Units* -

Route P48 harness through unit to control area in the same manner as they were removed. Connect P48 to J48 and screw GND terminal to control panel as shown in figure 4.

LG/LC/LH/LD Units -

Connect P48 to J48 in blower compartment. Screw GND terminal to blower deck in the same manner it was removed.

20- *Older SGH/SCH Units* -

Locate harness provided in the kit and connect the 9-pin plug to the blower Modbus/P335 control harness. Route the J335 end of the harness through

the unit to the control area in the same manner it was removed. Connect J335 to P335.

Newer SGH/SCH and LG/LC/LH/LD Units -

Discard the kit harness. Connect the Modbus plug in the blower area to the blower motor 9-pin control plug.

21- Bundle harnesses and use wire ties to secure kit harnesses to unit harnesses in the same manner they were removed.

Warranty Return

Package malfunctioned motor / impeller in the same manner as the replacement was provided. Use the same packaging. Return malfunctioned motor / impeller along with a copy of the warranty claim form to the nearest LPP store or warehouse.

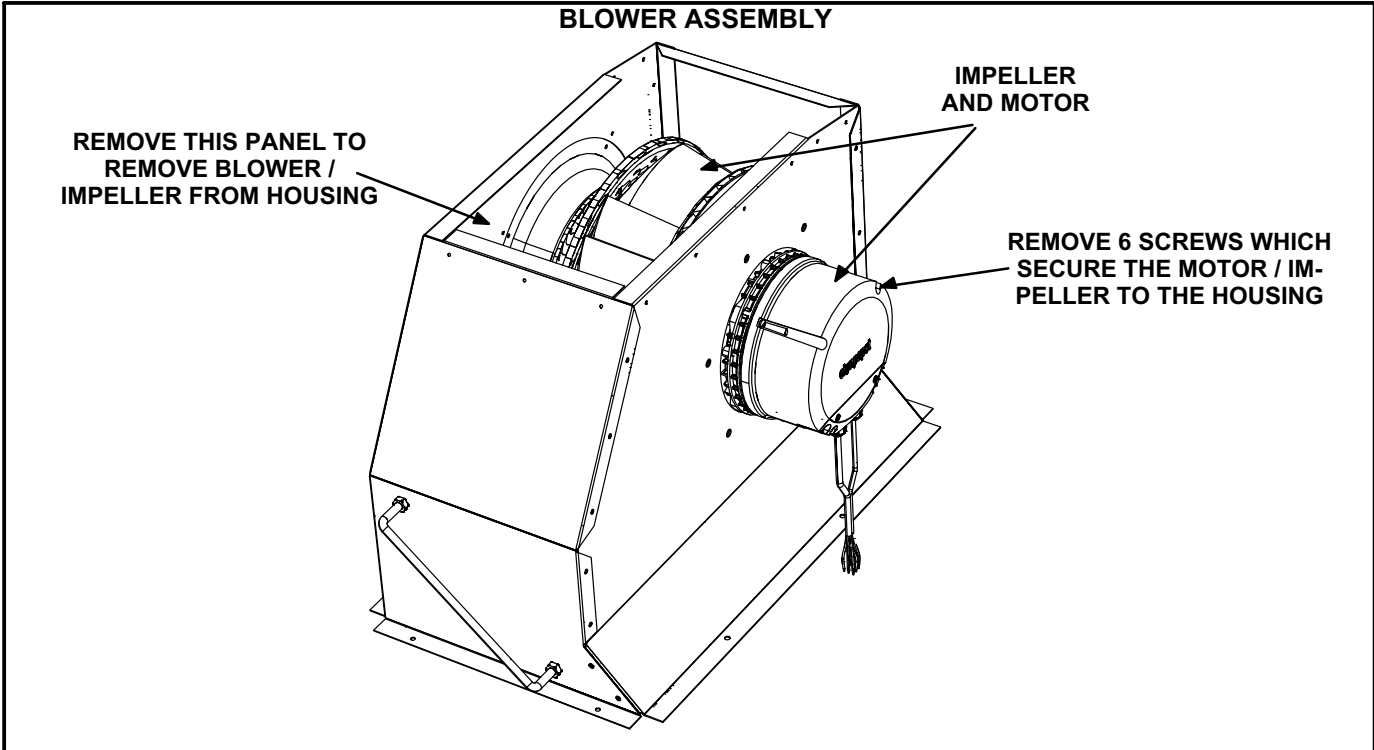

FIGURE 6

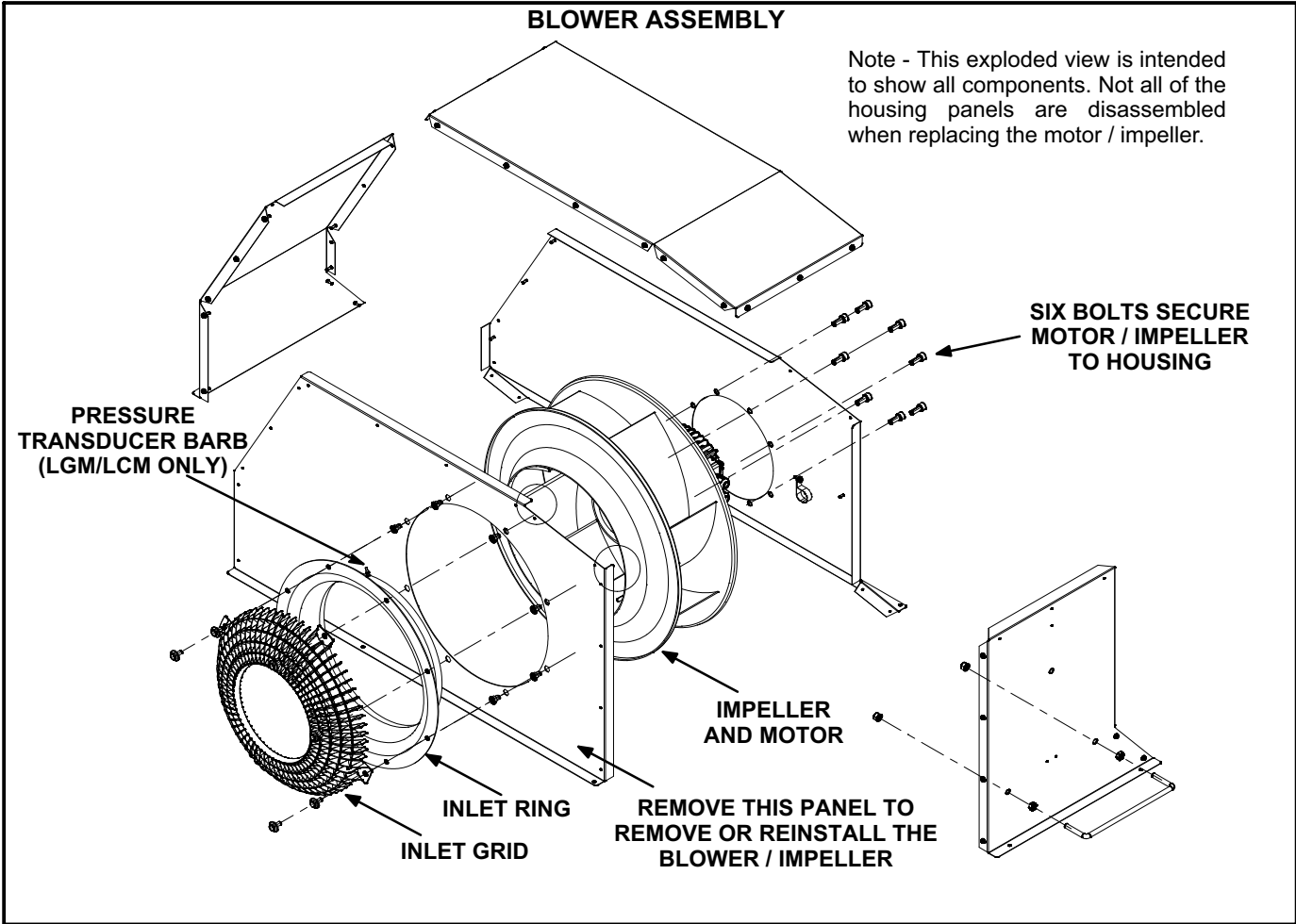

FIGURE 7