

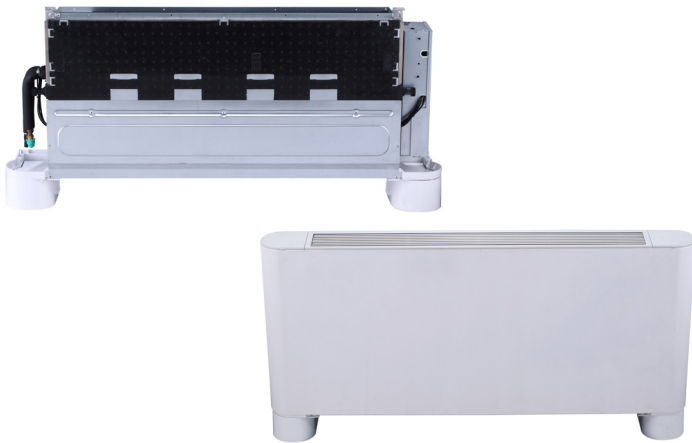

# VRF

©2020 Lennox Industries Inc. Dallas, Texas, USA



**THIS MANUAL MUST BE LEFT WITH THE OWNER FOR FUTURE REFERENCE**

### **⚠ WARNING**

**Improper installation, adjustment, alteration, service or maintenance can cause property damage, personal injury or loss of life.**

**Installation and service must be performed by a licensed professional HVAC installer, service agency or the gas supplier.**

**Failure to follow safety warnings and these instructions exactly could result in property damage, dangerous operation, serious injury, or death.**

**Any additions, changes, or conversions required in order for the appliance to satisfactorily meet the application needs must be made by a licensed professional HVAC installer (or equivalent) using factory-specified parts.**

**Do not use this system if any part has been under water. A flood-damaged appliance is extremely dangerous. Immediately call a licensed professional HVAC service technician (or equivalent) to inspect the system and to replace all controls and electrical parts that have been wet, or to replace the system, if deemed necessary.**

**The State of California has determined that this product may contain or produce a chemical or chemicals, in very low doses, which may cause serious illness or death. It may also cause cancer, birth defects, or reproductive harm.**

### **⚠ CAUTION**

**As with any mechanical equipment, personal injury can result from contact with sharp sheet metal edges. Be careful when you handle this equipment.**

# INSTALLATION INSTRUCTIONS

## VSCA Floor Standing Cased / VSEA Floor Standing Exposed

VRF SYSTEMS -- Floor Standing Indoor Units  
508061-01  
03/2020

### General

The VSC Floor Standing Cased / VSE Floor Standing Exposed non-ducted indoor units are matched with an outdoor heat recovery or heat pump unit to create a VRF (variable refrigerant flow) system that uses HFC-410A refrigerant. Refer to the Product Specification bulletin (EHB) for the proper use of these indoor units with specific heat pumps, heat recovery units, mode switching devices, branch pipes, line sets and controls.

These instructions are intended as a general guide and do not supersede local codes in any way. Consult authorities having jurisdiction before installation.

### Shipping and Packing List

Check the components for shipping damage. If you find any damage, immediately contact the last carrier.

Package 1 of 1 contains the following:

- 1 - Assembled indoor unit
- 4 - Foot bolts
- 1 - Receiver/Display panel
- 2 - Refrigerant piping insulation sleeves
- 1 - Resistor
- 2 - Brass flare nut
- 1 - Controller Wiring harness
- 1 - Water level switch cable
- 1 - Installation manual

Optional accessories, purchased separately:

- 1 - Wired controller V0STAT55P-3 (19X69)
- 2 - Base (VSEA only)
- 2 - Support feet V8VSA001-3P (19X68)

## Safety Requirements

### ⚠ WARNING

#### ELECTRICAL SHOCK, FIRE, OR EXPLOSION HAZARD.

Do not touch the unit or the controller if your hands are wet.

DO NOT spray water on the indoor unit for any reason.

Do not replace a fuse with a fuse of a different rating. Do not use a jumper wire to replace a fuse. Do not insert your hands, tools or any other item into the air intake or air outlet at either the indoor or outdoor unit.

Do not allow children to operate the system.

## Model Number Identification

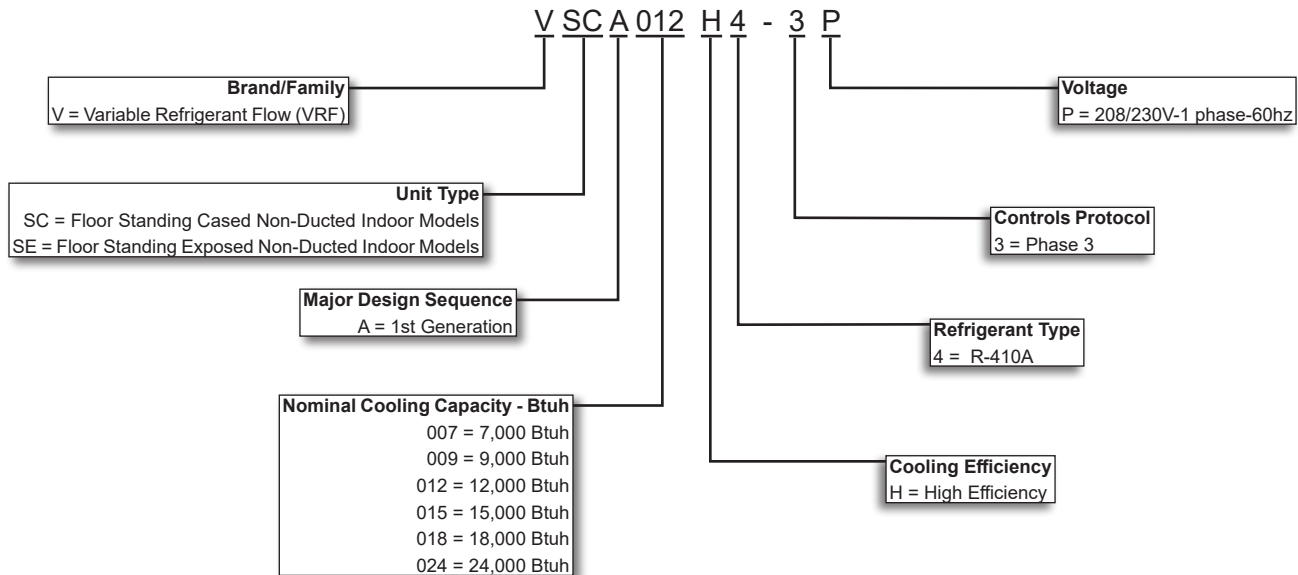

## System Piping

### ⚠ CAUTION

VRF system piping is customized for each installation. The LVSS piping report is an engineered design that must be followed. The piping diagram or diagrams included within the LVSS report have been prepared based on the information provided to the Lennox VRF applications department.

When the indicated lengths change from the figures stated within the report, it is imperative that prior to the commencement of the refrigerant pipe work installation, Lennox VRF applications department are informed of these proposed changes.

Upon receipt of this new information the Lennox VRF applications department will confirm any changes that may be applicable to this installation. If changes are required, a new piping diagram will be produced and will supersede all other previously provided documents.

Failure to provide this information regarding changes to the original design may lead to insufficient capacity, equipment failure, warranty being made void and the refusal to commission the system.

**Dimensions - VSCA Cased**

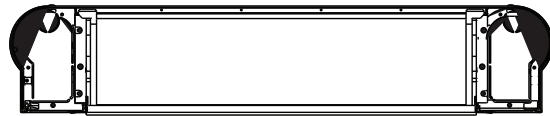

**BOTTOM OF UNIT**

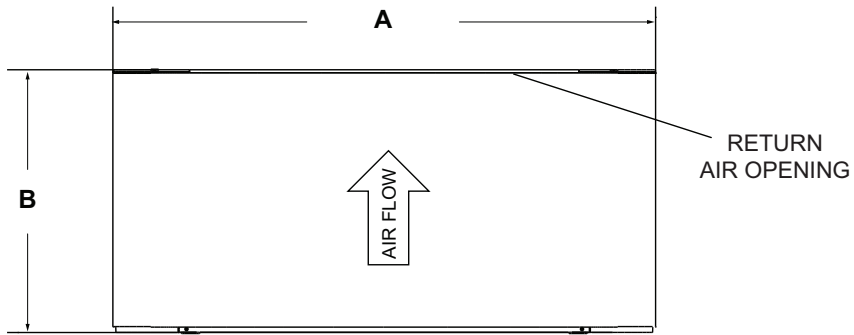

**FRONT VIEW**

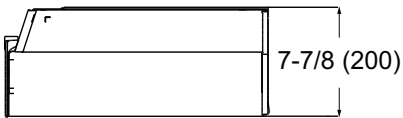

**RIGHT SIDE VIEW**



**TOP OF UNIT**

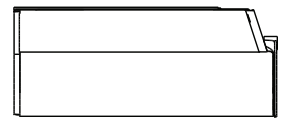

**LEFT SIDE VIEW**

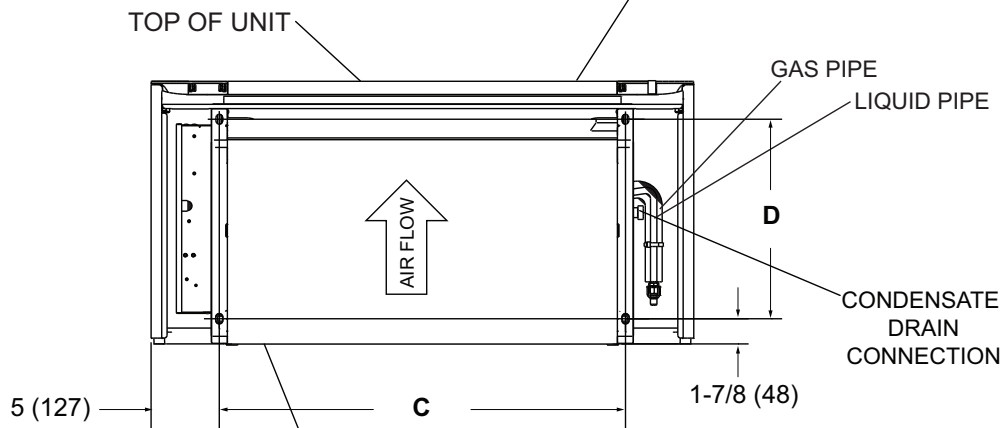

**BACK VIEW**

Unit Model	VSCA007, 009, 012		VSCA015		VSCA018		VSCA024	
	Inches	MM	Inches	MM	Inches	MM	Inches	MM
<b>A</b>	40-1/8	1019	48-7/8	1241	53-1/2	1359	53-1/2	1359
<b>B</b>	19-1/2	495	19-1/2	495	23-1/4	591	23-1/4	591
<b>C</b>	30	762	38-3/4	984	43-1/2	1105	43-1/2	1105
<b>D</b>	14-3/4	375	14-3/4	375	15-3/8	391	15-3/8	391

**Dimensions - VSCA Cased**

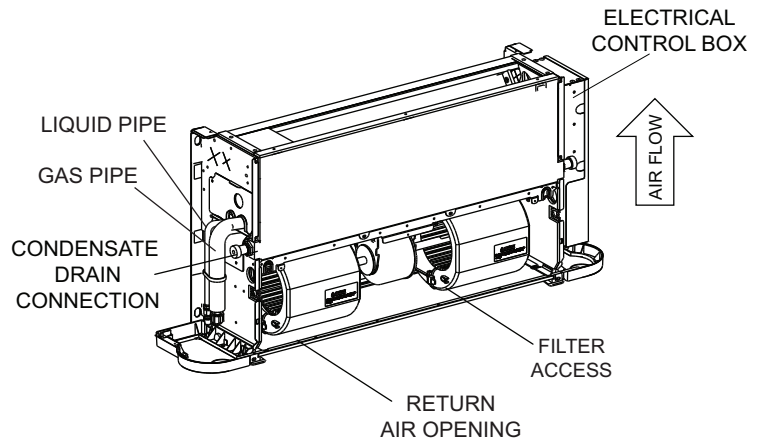
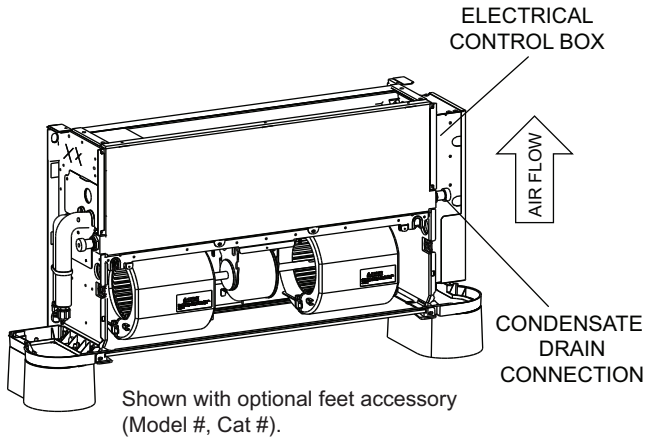

**Dimensions - VSCE Exposed**

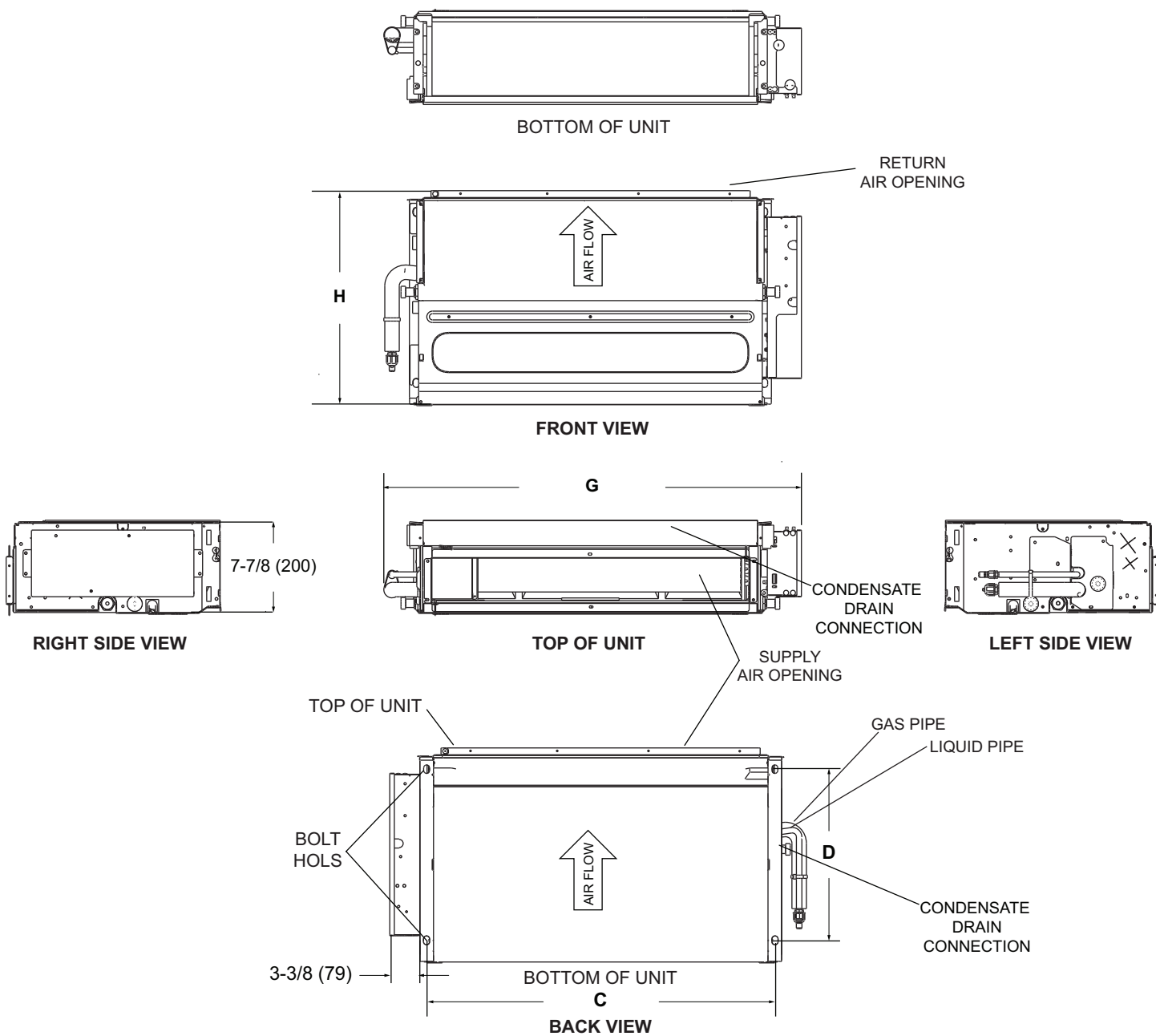

Unit Model	VSEA007, 009, 012		VSEA015		VSEA018		VSEA024	
	Inches	MM	Inches	MM	Inches	MM	Inches	MM
<b>C</b>	30	762	38-3/4	984	43-1/2	1105	43-1/2	1105
<b>D</b>	14-3/4	375	14-3/4	375	15-3/8	391	15-3/8	391
<b>G</b>	36	914	44-5/8	1133	49-3/8	1254	49-3/8	1254
<b>H</b>	18-1/2	470	18-1/2	470	22-1/4	565	22-1/4	565

**Dimensions - VSCE Exposed**

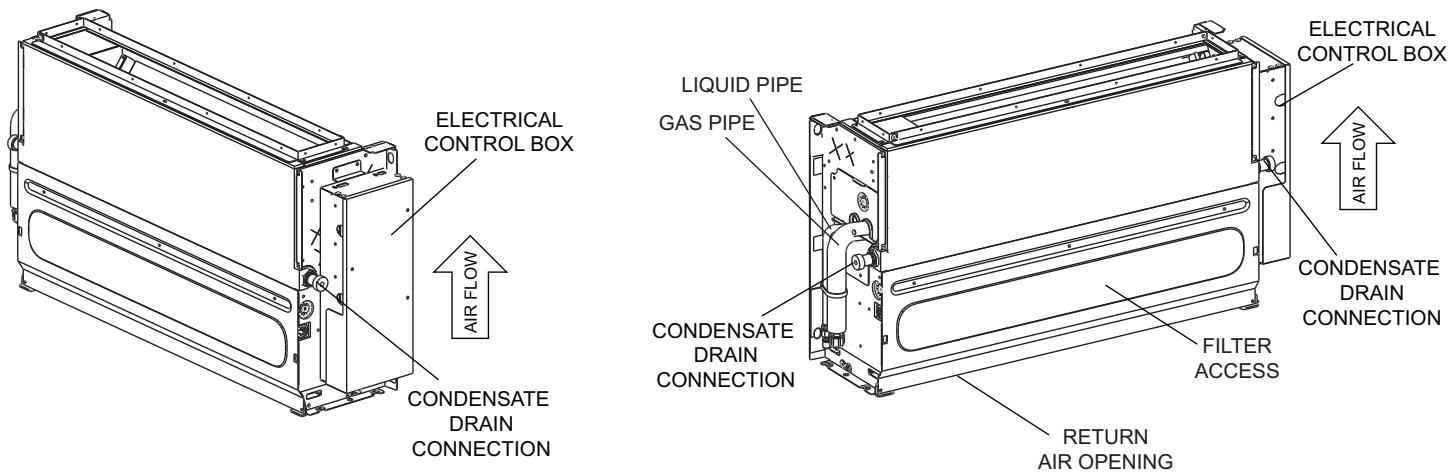

**Clearances**

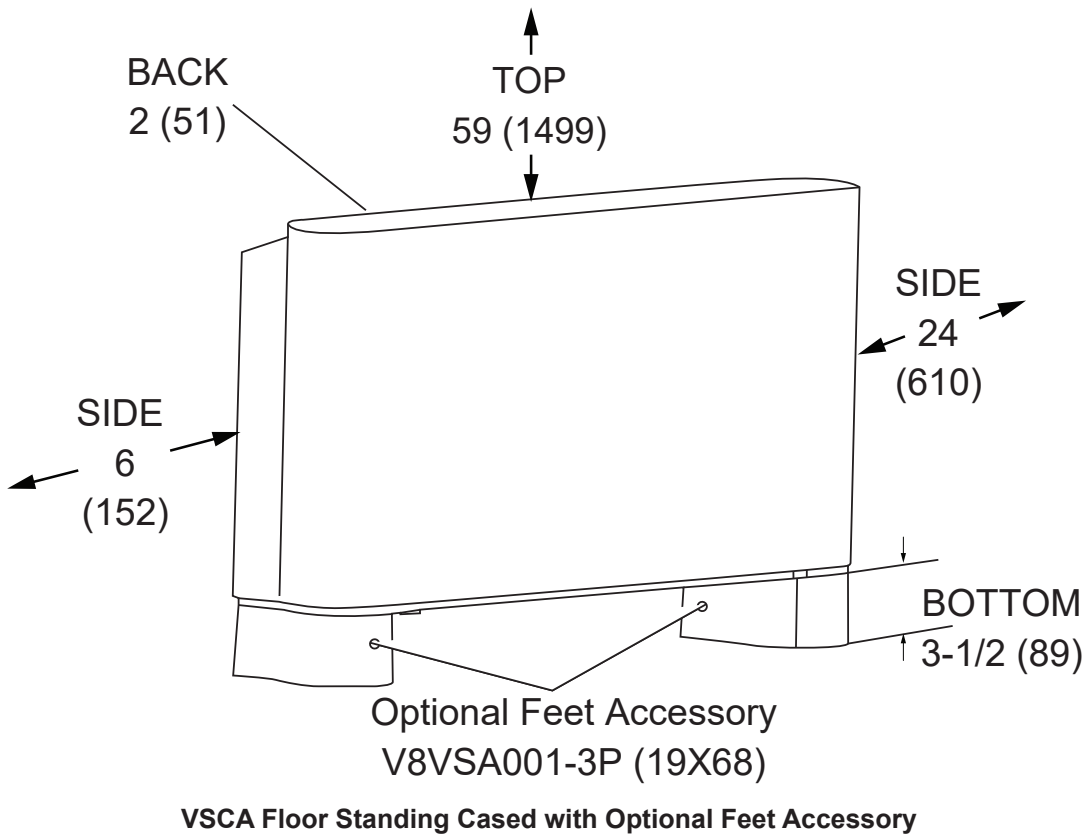
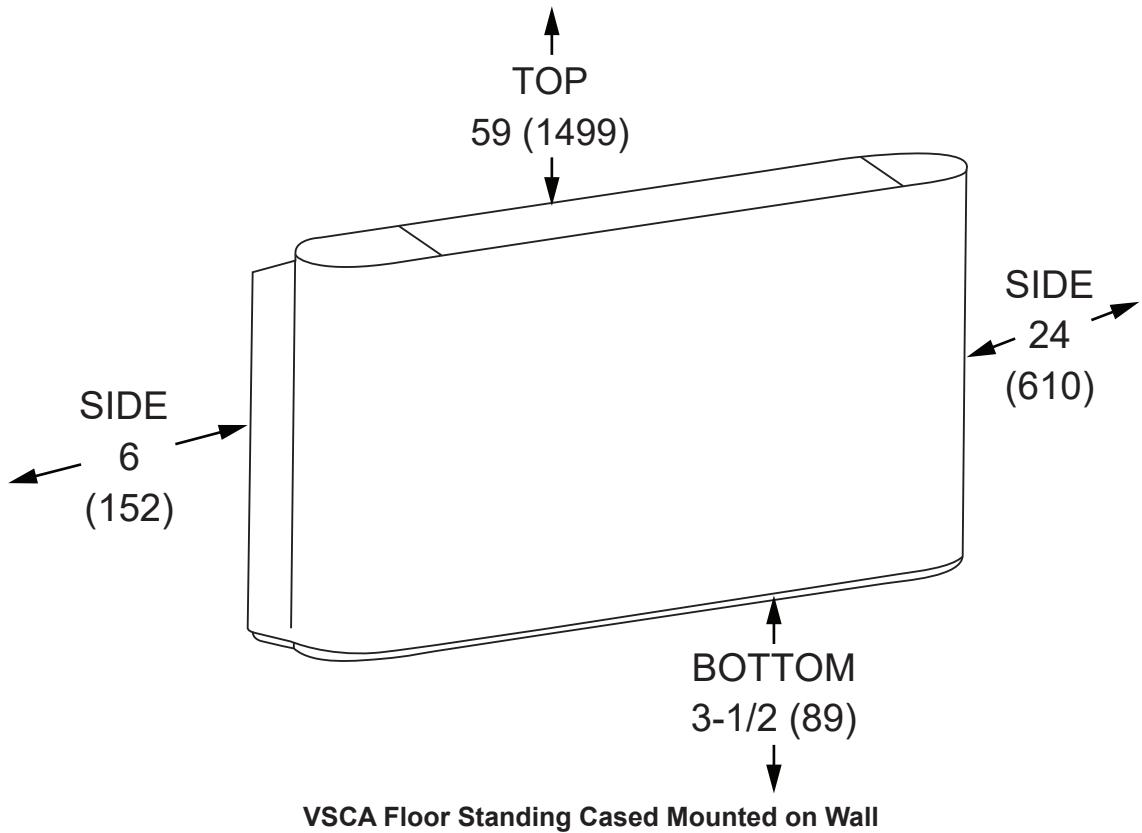

**Clearances**

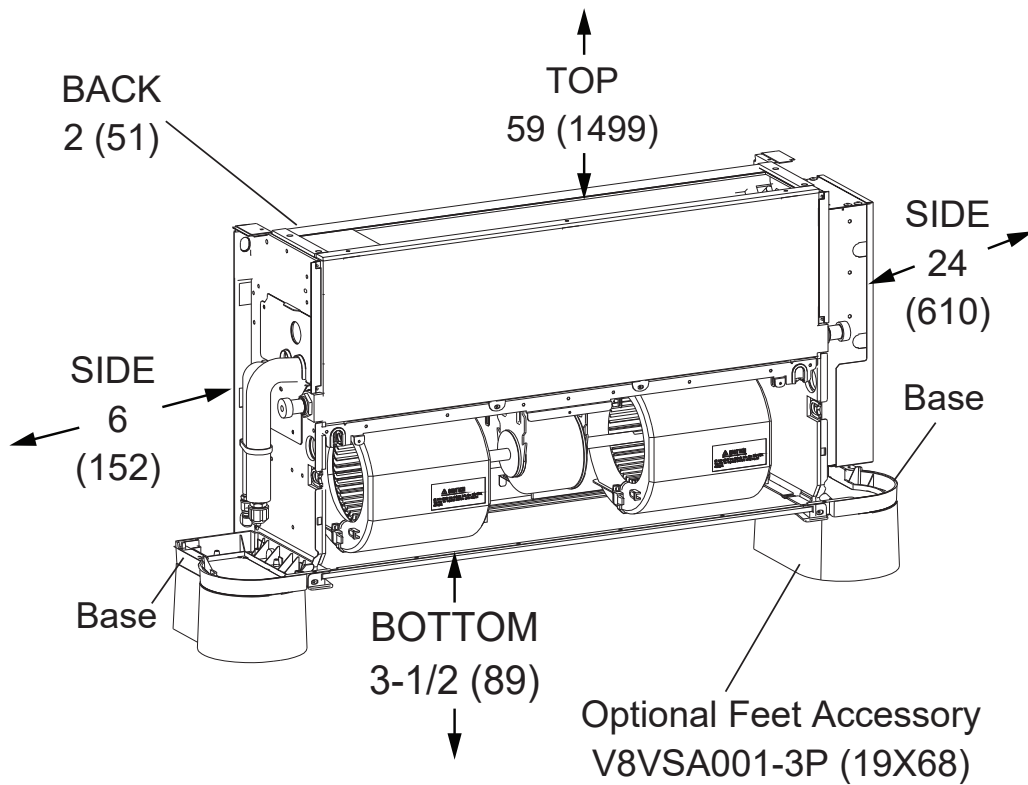
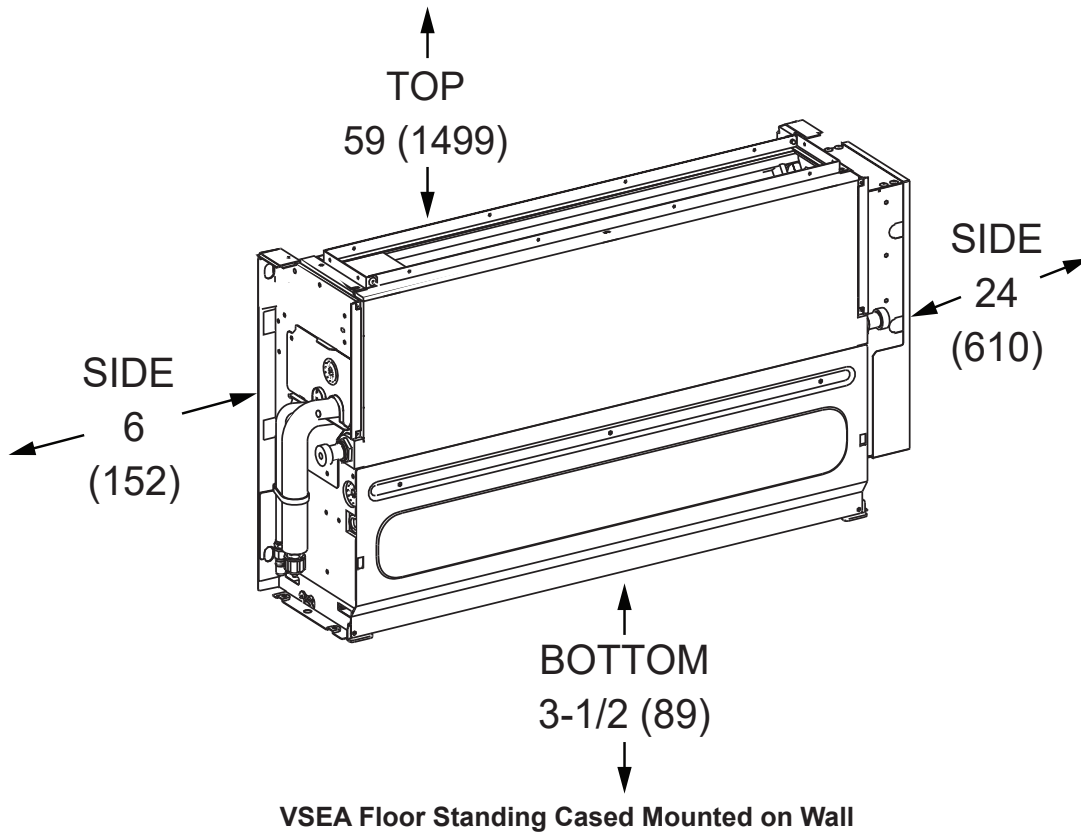

**VSEA Floor Standing Exposed with Optional Feet Accessory**



## Unit Placement

In addition to clearances, the following items should be considered:

### ▲WARNING

Use the provided and specified components when installing equipment. Failure to do so may result in unit falling, water leaking or electrical shocks, causing personal injury or equipment or property damage. Check stability of wall, floor, or ceiling and unit support. If support is not capable of carrying weight of the unit, unit may fall causing personal injury or equipment damage.

Consider the possibility of earthquakes in your area when installing the equipment. If the unit is not correctly secured, it may fall, causing personal injury or equipment damage.

Safely dispose of packing materials, which include nails, wood and other sharp objects, as well as plastic wrapping. Children playing with plastic wrap or bags risk the danger of suffocation.

### ▲CAUTION

Do not place items which may be damaged by water under or around the indoor unit.

The unit should be installed at least 8 feet above the floor (if possible) to ensure maximum performance and comfort, when installed in the horizontal position only.

### AVOID

Do not install the unit in the following locations:

- Areas exposed to petrochemicals or petrochemical products
- Areas exposed to salt or other corrosive materials or caustic gasses
- Areas exposed to extreme voltage variations (such as factories)
- Tightly enclosed areas that may impede service of the unit
- Areas exposed to fossil fuels (such as oil or gas in kitchens)
- Areas exposed to strong electromagnetic forces
- Areas exposed to acids or alkaline detergents (laundry rooms)

### DO:

- Locate the unit so that it is not exposed to direct sunlight
- Locate the indoor unit so that the room can be uniformly cooled.
- Ensure the structural wall or floor can support the weight of the unit.
- Select a location where condensate line will have the shortest run to a suitable drain per local codes.

- Allow sufficient space around unit for proper operation and maintenance (filter must be able to be removed from the front/bottom of the unit).
- Install unit a minimum of 3 feet away from any antenna, power cord (line) radio, telephone, security system, or intercom. Electrical interference and radio frequencies from any of these sources may affect operation
- Be sure to instruct customers how to properly operate the unit (especially maintenance of air filter, and operation procedure) by having them carry out operations themselves while looking at the manual provided with the controller.

## Installation

1. Locate a suitable position within the space where maintenance access and supply air will not be restricted or affected by obstacles. The minimum clearances are given on Page 5.

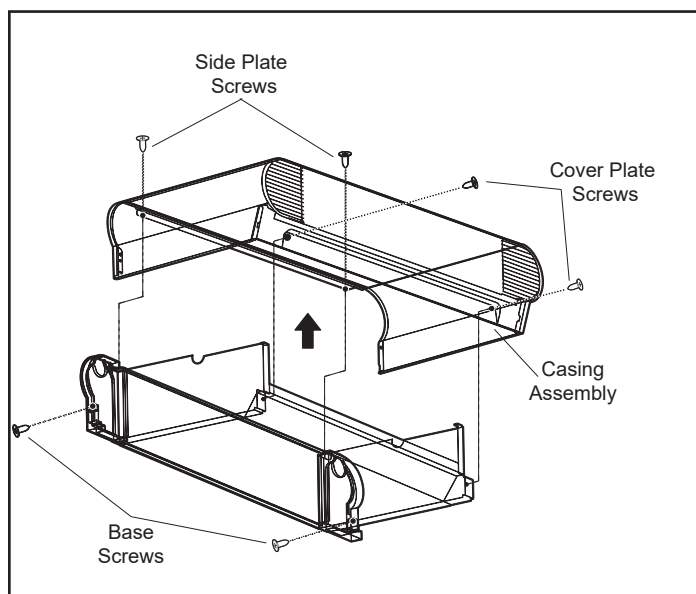
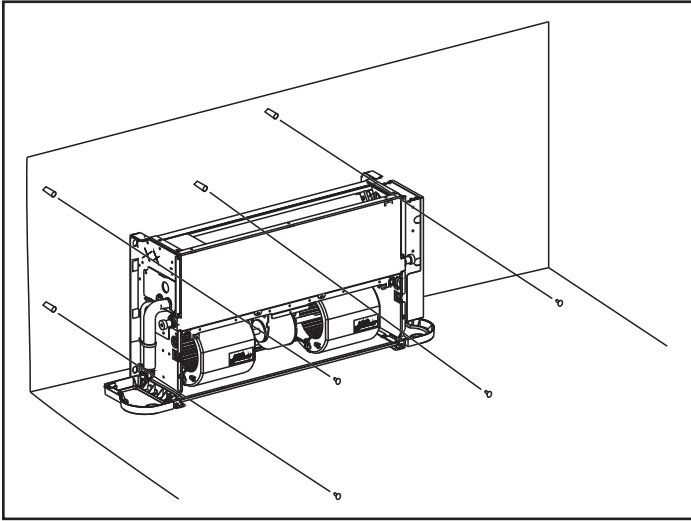

**Figure 1. Remove Casing Assembly (VSC Only)**

1. Remove the unit casing (VSC units only) by removing the six screws shown in Figure 1. After installation is complete, re-install the unit casing by replacing the cover plate and side plate screws. It is not necessary to replace the base screws.
2. The unit can be secured to a wall or mounted on optional support feet V8VSA001-3P (19X68).

## Secure to Wall (VSC or VSE Units)

Locate the unit on a wall which is both capable of supporting the unit's weight and which is constructed to enable the unit to fit flush on the wall. An uneven wall may lead to vibration and subsequent unit damage.

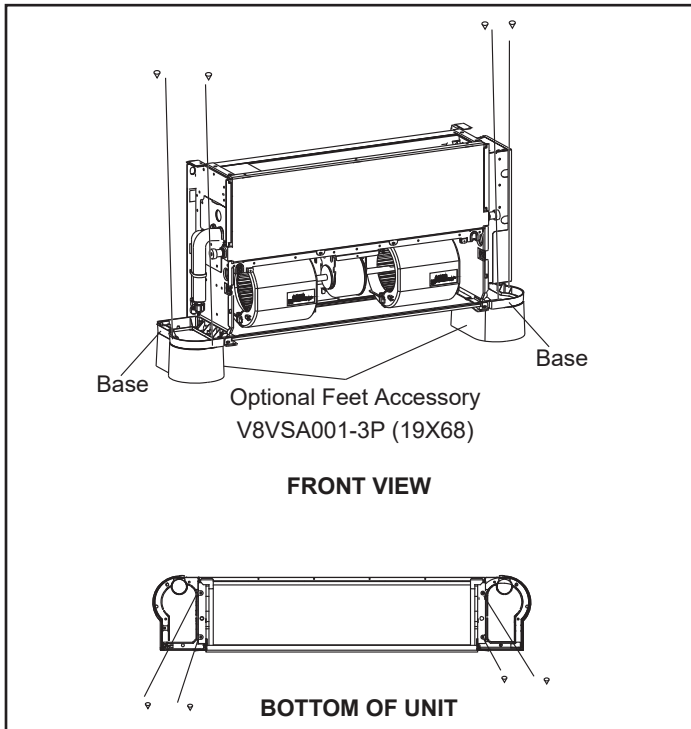

**Figure 2. Secure to Wall**

1. Mark the locations of the screws on the wall and use suitable fasteners to secure the four mounting holes to the wall. See Figure 2, and the dimension drawings on Page 4 to ensure proper positioning of the unit.
2. The unit should be installed high enough for a gravity drain to function properly. If necessary, a field provided external pump can be installed at the unit. See Page 4 for pipe connection locations.

## Mount to Optional Feet

1. Place the mounting holes on the unit base into the corresponding feet locating pin and install four screws as shown in Figure 3.



**Figure 3. Mount to Optional Feet**

## Refrigerant Piping Connections

### **⚠ WARNING**

Refrigerant leaks are unlikely; however, if a refrigerant leak occurs, open a door or windows to dilute the refrigerant in the room. Turn off the unit and all other appliances that may cause a spark. Call a licensed professional HVAC technician (or equivalent) to repair the leak.

Use only R410A refrigerant to charge this system. Use of other refrigerant or gas will damage the equipment. Do not allow air or other contaminants to enter system during installation of refrigerant piping. Contaminants will result in lower system capacity and abnormally high operating pressures and may result in system failure or explosion.

Insulate all refrigerant piping.

Refrigerant pipes may be very hot during unit operation. Do not allow contact between wiring and bare copper pipes.

After refrigerant piping connections have been completed, check the system for leaks per commissioning instructions.

Field piping consists of two copper lines connected to the indoor unit. Table 1 lists the connection sizes at the indoor unit. The connections are made using the provided brass flare nuts at the end of the refrigerant piping connections.

### **Both lines must be individually insulated.**

1. The seal on the unit refrigerant piping connections should remain in place until the last possible moment. This will prevent dust or water from getting into the refrigerant piping before it is connected.
2. Slowly loosen one of the flare nuts to release the factory nitrogen charge.
3. Remove the flare nuts from the connections on the unit and discard the seal from each of the piping connections.
4. Slide the flare nuts onto the ends of the field-provided refrigerant piping **before** using a suitable flaring tool to flare the end of the copper pipe.
5. Apply recommended HFC-410A refrigerant lubricant to the outside of the flared refrigerant lines (Figure 4-A).
6. Align the threaded connections with the flared refrigerant lines. Tighten the flare nuts lightly at first to obtain a smooth match (Figure 4-B).
7. Once snug, continue another half-turn on each nut which should create a leak-free joint. A torque wrench may be used to tighten flare nuts using Table 2 recommendations. See Figure 5. **Do not over-tighten a flared joint. Flared connections should always be accessible and must be insulated to prevent condensation.**

8. After refrigerant piping has been installed and checked for leaks, apply insulation over all flared joints ensuring an air tight seal has been made between unit connections and field supplied insulated piping. All field piping connections shall be insulated and air tight to prevent unwanted condensation build-up. Figure 6.

**! IMPORTANT!**

The compressor in this unit contains PVE oil (Polyvinylether). PVE oil is formulated for hydrofluorocarbon (HFC) refrigerants, such as R-410a, which this system contains. While it may have some miscibility properties with mineral-based oil and POE oil (Polyolester), it is not recommended to mix PVE oil with any other type of refrigerant oil.

**Table 1. Refrigerant Piping Connections**

Nominal Capacity (Btuh)	Liquid Line in.	Vapor Line in.
7000	1/4	1/2
9000		
12000		
15000		
18000		
24000	3/8	5/8

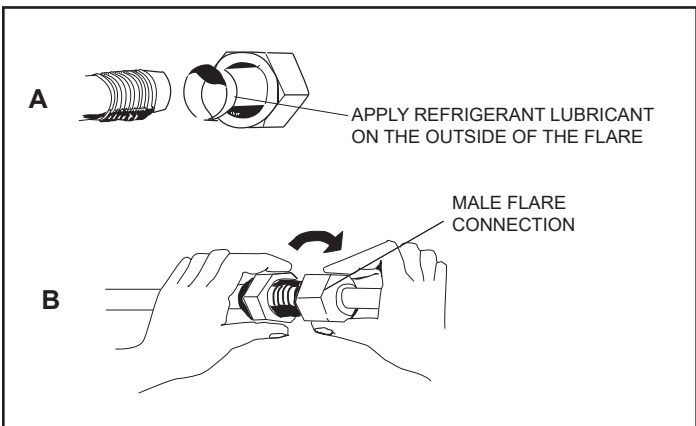

**Figure 4. Making Connections (Male to Female Connection)**

**! IMPORTANT!**

Always use two wrenches when tightening flare nuts to avoid twisting refrigerant piping. **DO NOT** over-tighten flare nuts.

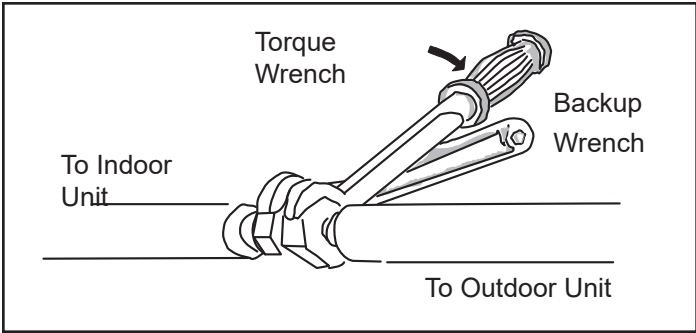

**Figure 5. Tighten Flare Nut**

**Table 2. Flare Nut Torque Recommendations**

Outside Diameter	Recommended Torque	No torque wrench available Finger tighten and use an appropriately sized wrench to turn an additional:
Inches	U.S.	
1/4"	15 ft.-lb.	1/4 turn
3/8"	26 ft.-lb.	1/2 turn
1/2"	41 ft.-lb.	7/8 turn
5/8"	48 ft.-lb.	1 full turn

**! IMPORTANT**

Flared connections should always be accessible and must be insulated to prevent condensation. See Figure 6.

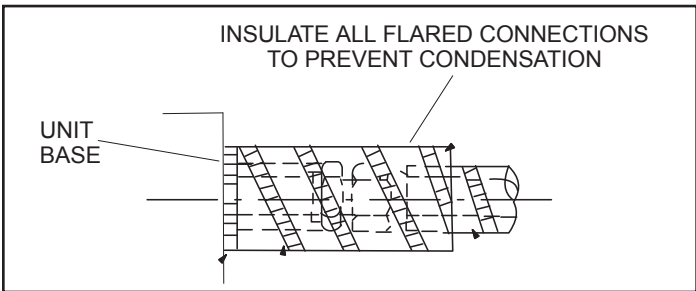

**Figure 6. Insulate Flared Connections**

**! IMPORTANT**

Support ALL piping within 12 in. (305 mm) of any mechanical fitting such as a flared connection.

## Condensate Piping Connections

### ⚠ CAUTION

Make sure that drain piping is properly routed and insulated in order to prevent both leaks and condensation.

1. Make a water-tight connection between the field-provided condensate drain line and the flexible condensate connector (1" O.D.).
2. Confirm proper slope (not less than 1/4 inch per foot) and routing of condensate lines to ensure moisture is drained away from the indoor unit.
3. Drain should be as short as possible and should not have any droops or kinks that would restrict condensate flow and shall be approved resistant pipe.
4. There must be a 2-inch space between the end of the condensate drain and the final termination point (ground, open drain, etc.) to ensure that the line will drain freely.
5. After the system installation is complete, the condensate drain line must be checked for leaks and proper drainage. If a field-provided condensate pump has been installed, it must be checked to ensure proper operation. This check is part of the commissioning sequence.

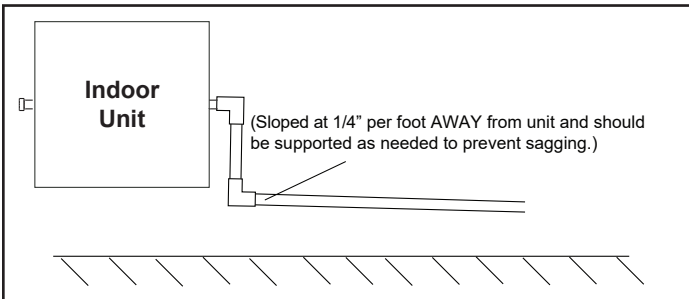

Figure 7. Single Indoor Unit Using a Properly Sloped Gravity Drain

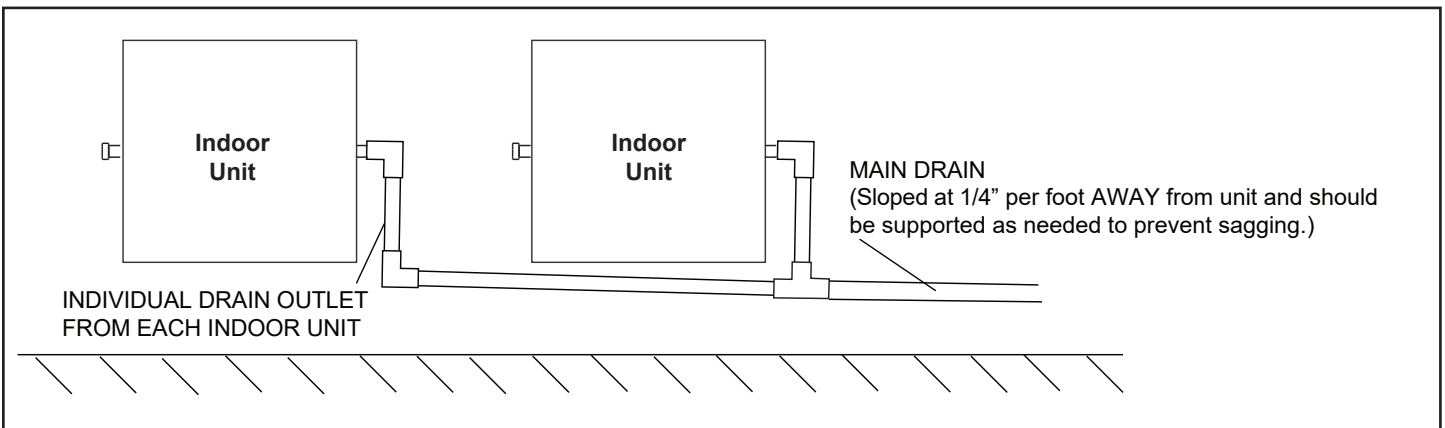

Figure 8. Multiple Indoor Units Using a Single Properly Sloped Gravity Drain

## IMPORTANT!

Drain should have a slope of at least 1/4 inch per foot and should be approved corrosion-resistant pipe. You must confirm operation of every drain and pump in the system as part of the commissioning procedure.

### Using an External Water Level Switch

Disconnect the closed circuit loop, CN 5. Connect the water level switch cable accessory to CN 5. See unit wiring diagrams for location of CN 5.

The connection has 5 VDC current, do not supply field voltage.

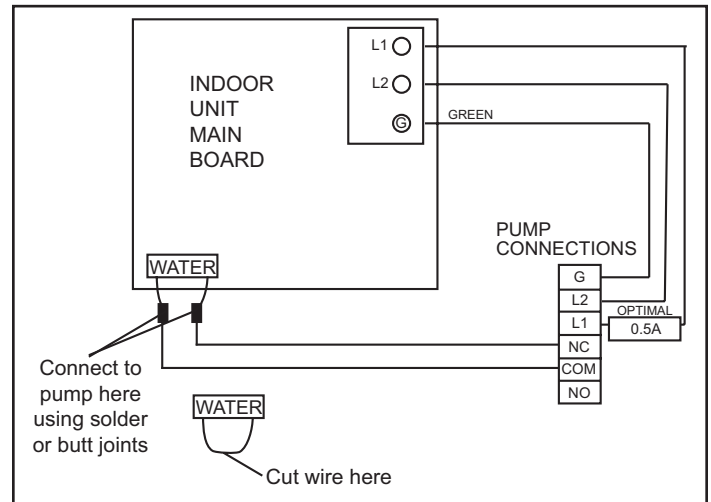

Figure 9. External Water Level Switch Connection

## Wiring Connections

### ⚠ WARNING

Isolate the power supply before accessing unit electrical terminals.

Install unit so that unit disconnect is accessible.

Follow all local and national codes, as well as this installation instruction, during installation. Do NOT overload electrical circuit, as this may lead to failure and possible fire.

Use specified wiring and cable to make electrical connections. Clamp cables securely and make sure that connections are tight to avoid strain on wiring. Insecure wiring connections may result in equipment failure and risk of fire.

Wiring must be installed so that all cover plates can be securely closed.

### ⚠ CAUTION

This unit must be properly grounded and protected by a circuit breaker. The ground wire for the unit must not be connected to a gas or water pipe, a lightning conductor or a telephone ground wire.

Do not connect power wires to the outdoor unit until all other wiring and piping connections have been completed.

Install all wiring at least 3 feet away from televisions, radios or other electronic devices in order to avoid the possibility of interference with the unit operation. Do not install the unit near a lighting appliance that includes a ballast. The ballast may affect remote control operation.

### ⚠ CAUTION

A disconnection device having an air gap contact separation in all active conductors should be incorporated in the fixed wiring according to the National Wiring Regulation.

In the U.S.A., wiring must conform with current local codes and the current National Electric Code (NEC). In Canada, wiring must conform with current local codes and the current Canadian Electrical Code (CEC). Refer to unit nameplate for minimum circuit ampacity and maximum overcurrent protection size.

*NOTE - Three-conductor shielded cable must be used for the communication wiring. This is necessary to ensure proper system communication and operation.*

- A circuit breaker capable of shutting down the power supply to the entire system must be installed.
- A single switch can be used to supply power to units on the same system. However, branch switches and circuit breakers must be selected carefully.

- Fit the power supply wiring of each unit with a switch and fuse as shown in the wiring diagram.
  - Install a wiring interrupter or ground-fault circuit interrupter for the power wiring.
  - Make sure the ground resistance is no greater than 100Ω. This value can be as high as 500Ω when using a grounding fault circuit interrupter since the protective ground resistance can be applied.
1. Pull the return air filter grille forward and remove the filters.
  2. Remove one screw from each safety strap assembly (one on each side) and remove return air grille.
  3. Locate the control box in the center of the unit, below and behind the fan motor.
  4. Remove the two screws holding the control box onto the motor mounting bracket, and the screw at each end of the control box holding securing the box to the chassis of the unit. Lower the control box to obtain access to cover.
  5. Remove the screws securing the cover and remove cover from control box.
  6. Locate the terminal strip in the control box. Connect the power wiring (sized per NEC/CEC and local codes) and communications cable (three-conductor shielded cable) per figures 12 and 13. Refer to unit nameplate for rated voltage.
  7. If the indoor unit is the final unit in a group that is wired in series, install the provided resistor across terminals P and Q. See figure 14.

### Tightening torque for the terminal screws

- Use the correct screwdriver for fighting the terminal screws. If the screwdriver blade is too small, the head of the screw might be damaged, and the screw will not be properly tightened.
- If the terminal screws are over tightened, screws might be damaged.
- Refer to the table below for the tightening torque of the terminal screws.

**Table 3. Terminal Screw Tightening Torque**

	Tightening torque (lb-ft)
Terminal base of remote controller/Signal transmission wire (X2M)	0.58-0.72
Terminal base of power supply (X1M)	0.87-1.06
Grounding terminal (M4)	1.06-1.43

- After wiring, confirm all connections are correct; Then turn on power supply to the unit.

Indoor units and MS boxes on the same refrigeration circuit should have a common power supply but must have an independent disconnect switch installed adjacent

to the fan coil for servicing and maintenance purposes. Indoor unit and MS box power supply MUST not be taken from the outdoor unit. Always follow NEC/CEC and Local Codes.

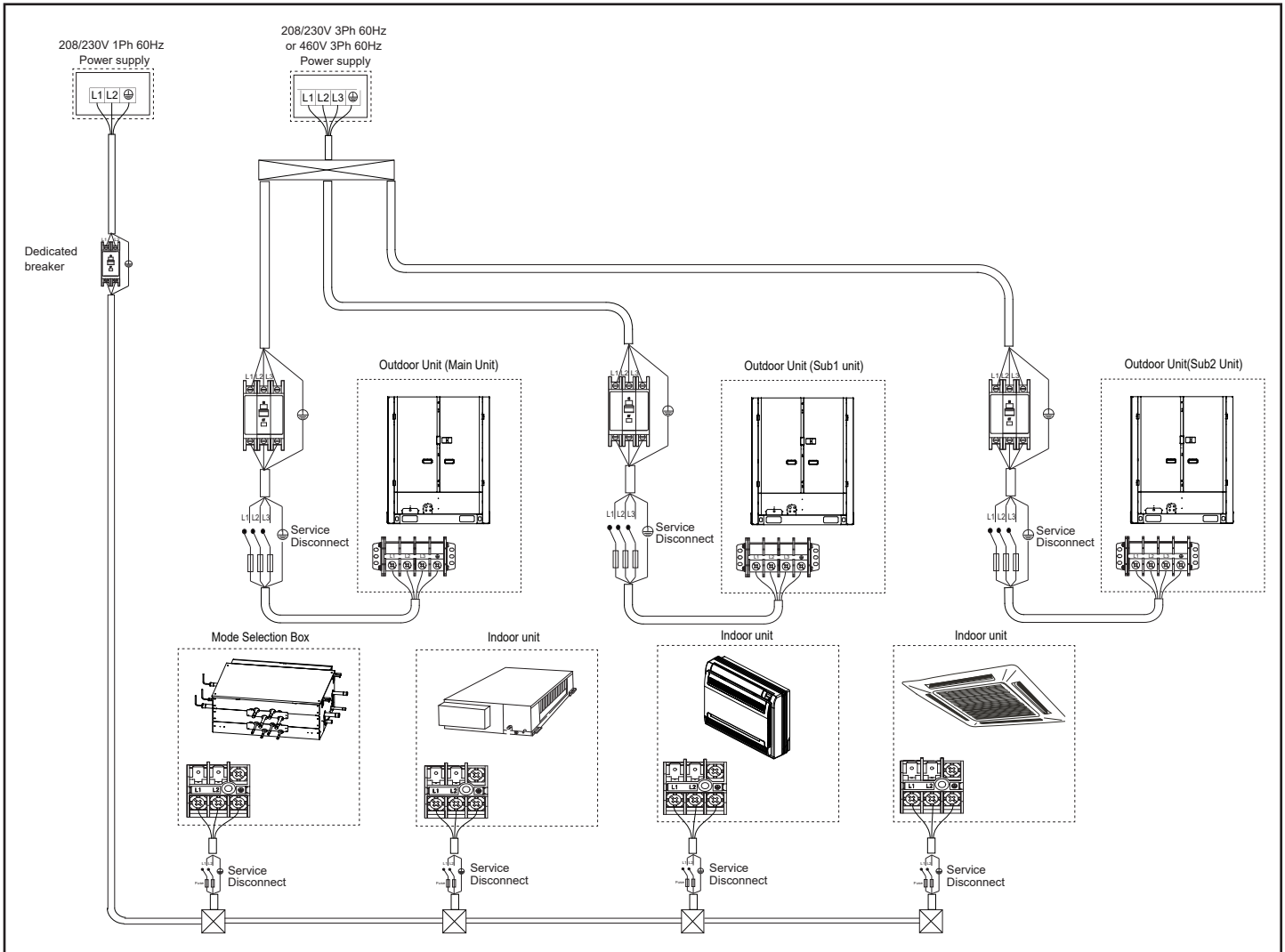
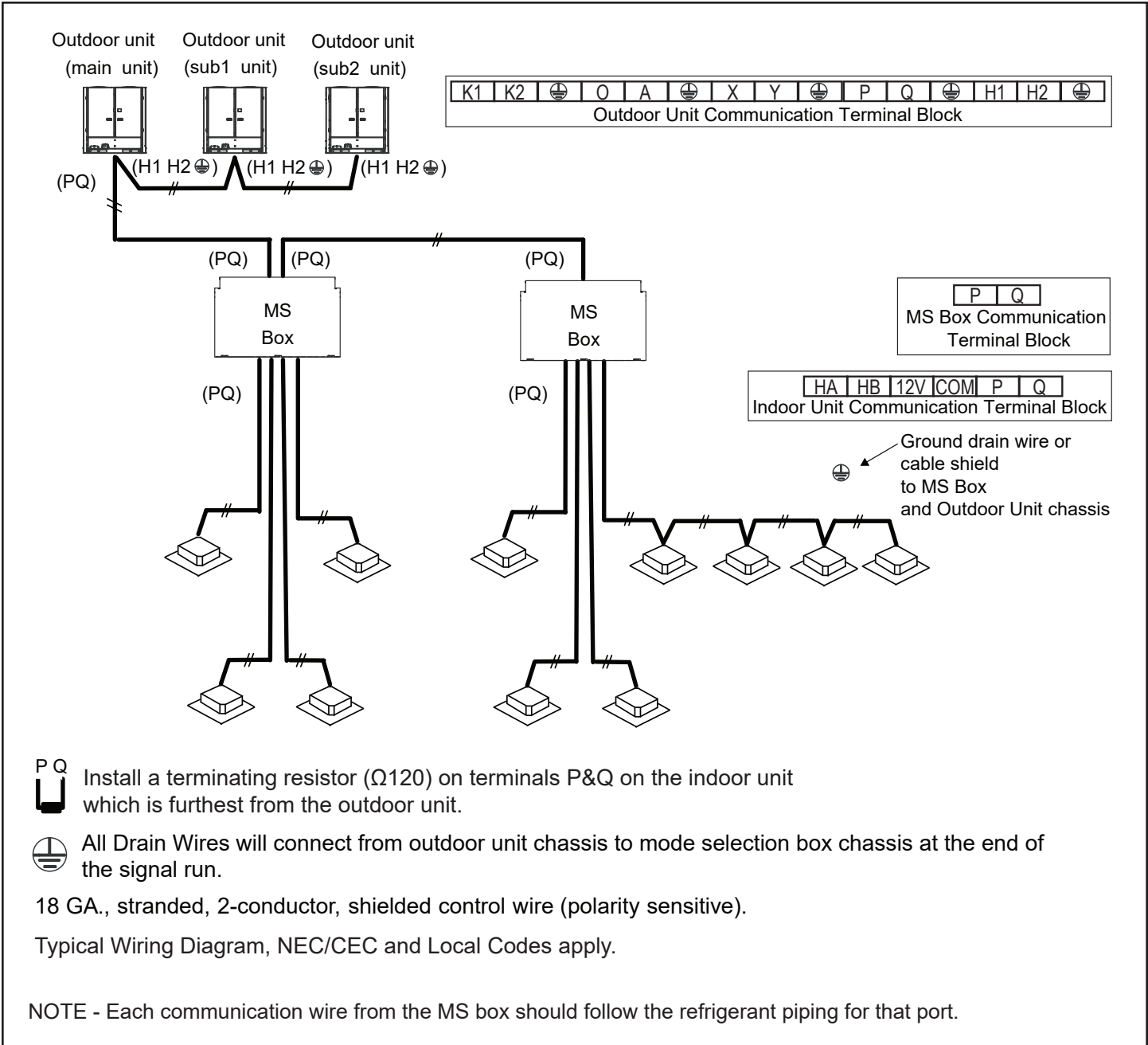

Figure 10. Typical Power Wiring Diagram (VRF Heat Recovery System Shown)

**⚠ IMPORTANT**

DO NOT adjust DIP switch settings. Settings may only be adjusted by a trained technician as part of the commissioning procedures.



**Figure 11. Typical Communication Wiring Diagram (VRF Heat Recovery System)**

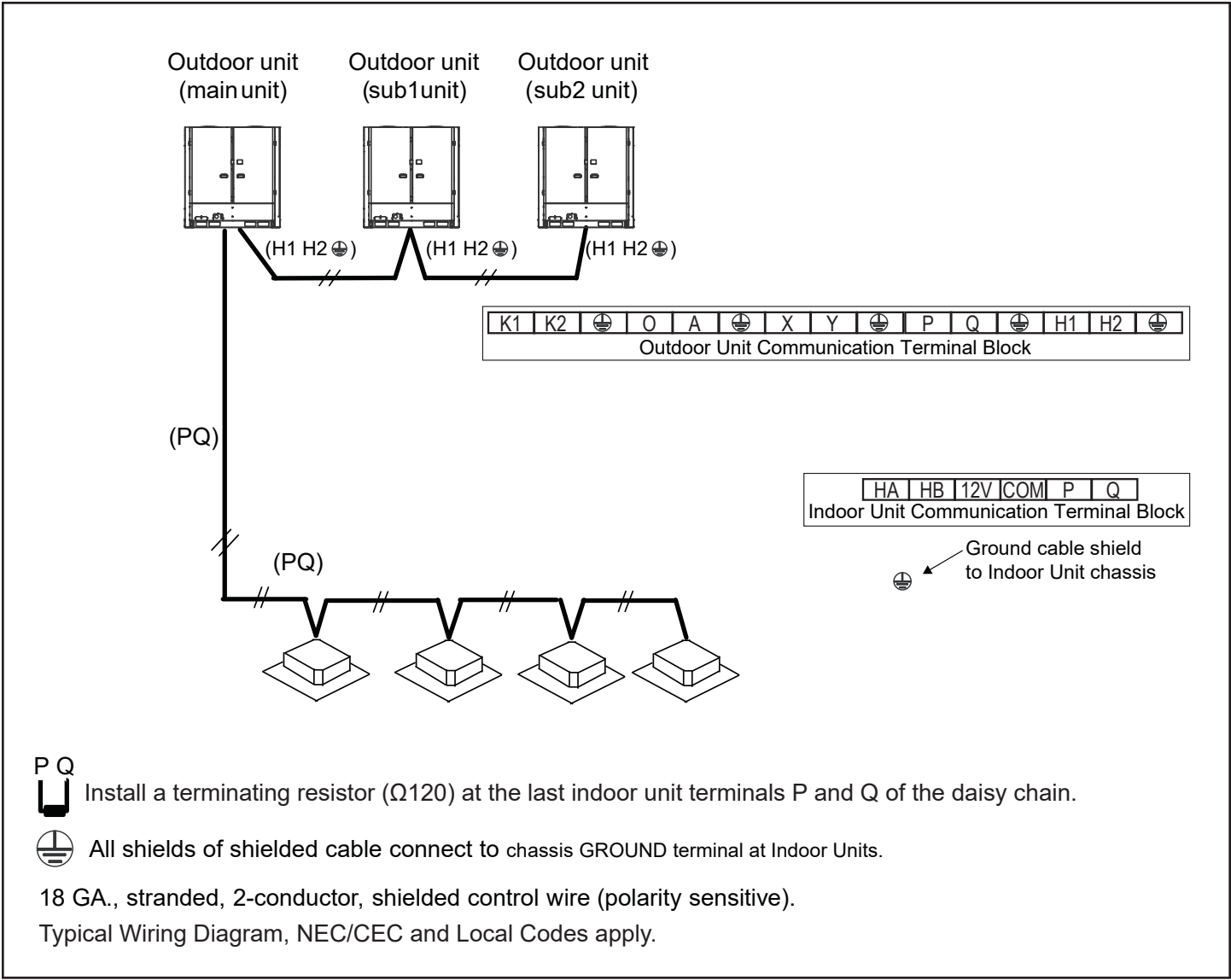

Figure 12. Typical Communication Wiring Diagram (VRF Heat Pump System)



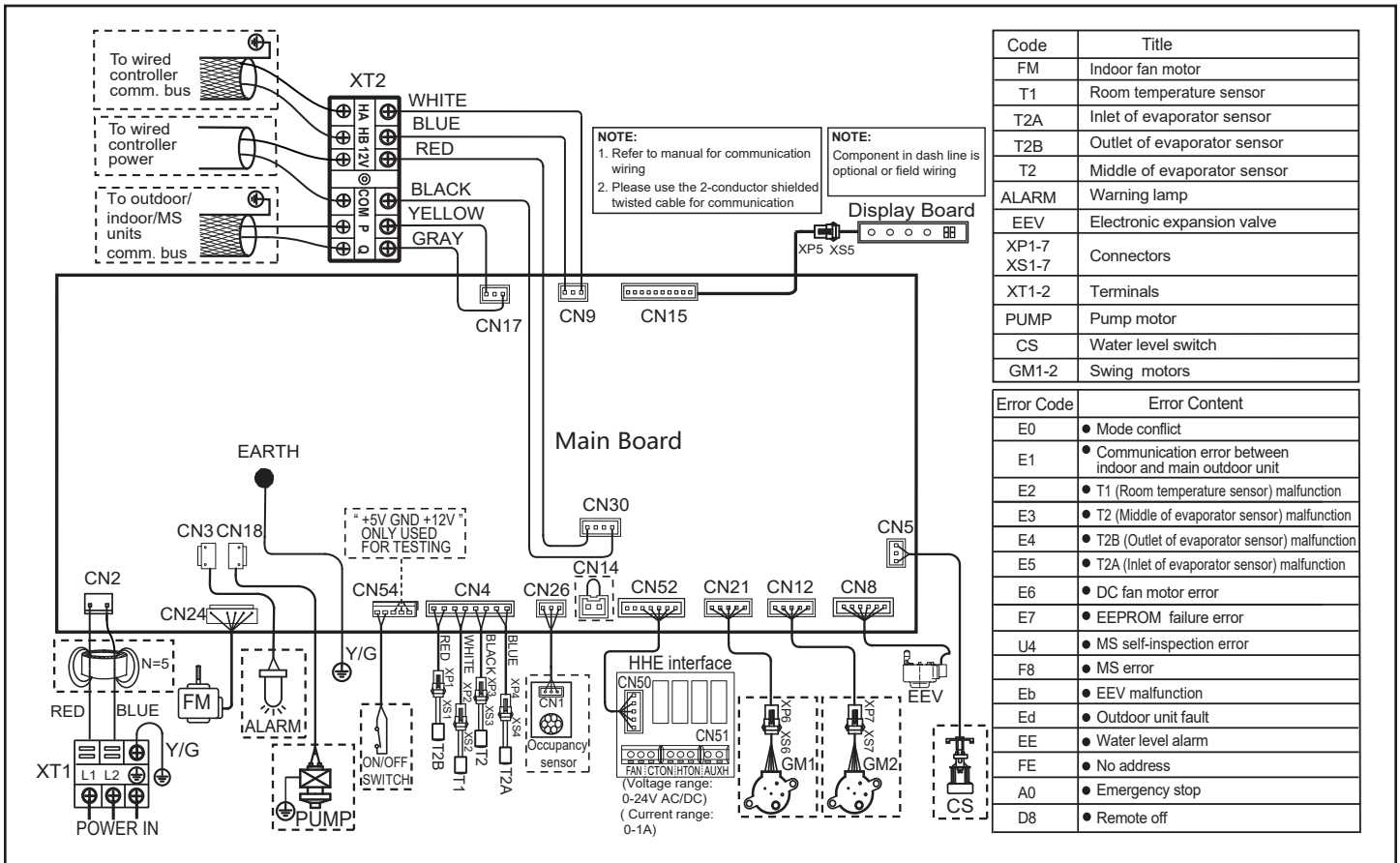

Figure 13. VSCA & VSEA Wiring Diagram

### Connect Receiver/Display

The unit's Receiver/Display is field installed and connected as shown in Figure 14.

1. Align the plastic tabs on the back of the receiver to the slots on the top of the unit's electrical control box and slide the tabs into the slots.

2. Connect the 10-wire harness connection to the unit's main control board CN 05.
3. Connect the 5-wire harness connection to the optional wired controller V0STAT55P-3 (19X69) if used.

See Page 14 for spot check and troubleshooting instructions using the Receiver/Display panel.

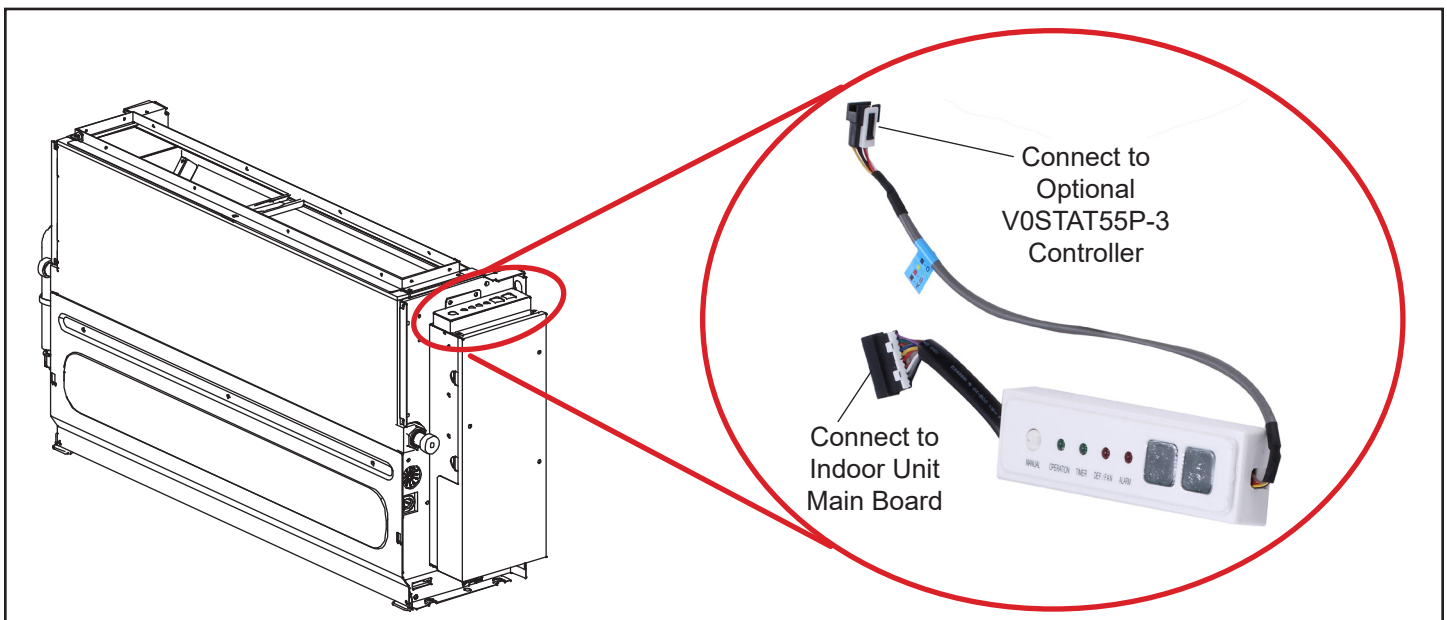

Figure 14. Install Receiver/Display

## Optional Wired Controller V0STAT55P-3 (19X69)



Figure 15. V0STAT55P-3 Controller Assembly

### General

V0STAT55P-3 is an optional wired non-programmable local controller that controls VSC/VSE Floor Standing indoor units. These instructions are intended as a general guide and do not supersede local codes in any way. Consult authorities having jurisdiction before installation.

### Shipping & Packing List

- 1 - Wired Controller
- 4 - Mounting screws
- 4 - Plastic anchors
- 1 - Connection Wiring Harness - 49 ft. (15 m)

### Requirements

- Be sure that the indoor unit power supply has been turned off before beginning installation.
- This controller should be used only as described in this manual.
- Do not install the controller on outside walls (where there is unconditioned space on opposite side of wall) or in locations where direct sunlight may be present.

Table 4. V0STAT55P-3 Specifications

Input voltage	12 VDC
Ambient temperature	23~110°F (-5~43°C)
Ambient humidity	RH40%~RH90%

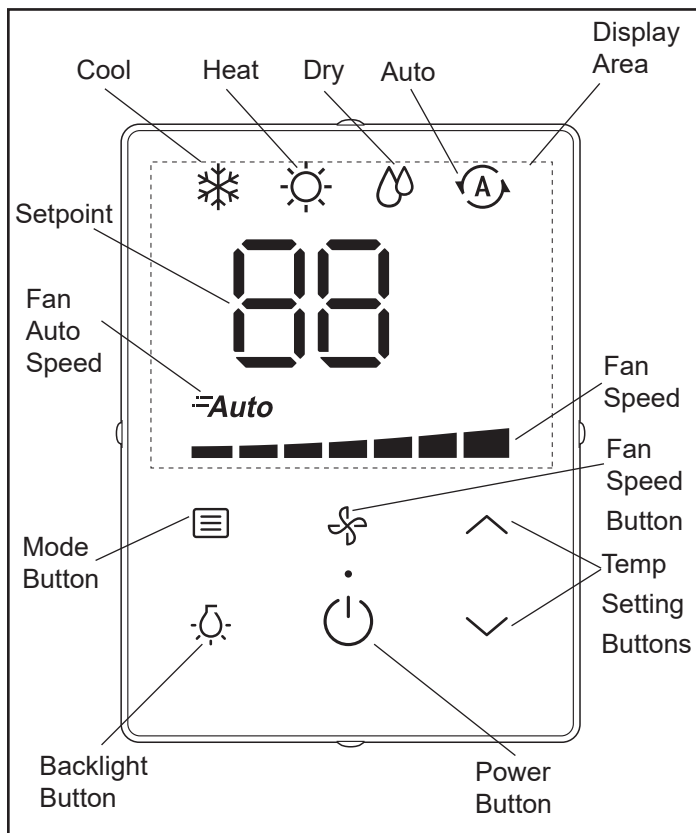

Figure 16. V0STAT55P-3 Display & Buttons

### ▲IMPORTANT

Frequent changes to operating mode may cause system malfunction. Allow at least one minute between mode changes to allow the system to stabilize.

### ▲IMPORTANT

Electrostatic discharge can affect electronic components. Take precautions to neutralize electrostatic charge by touching your hand and tools to metal prior to handling the control.

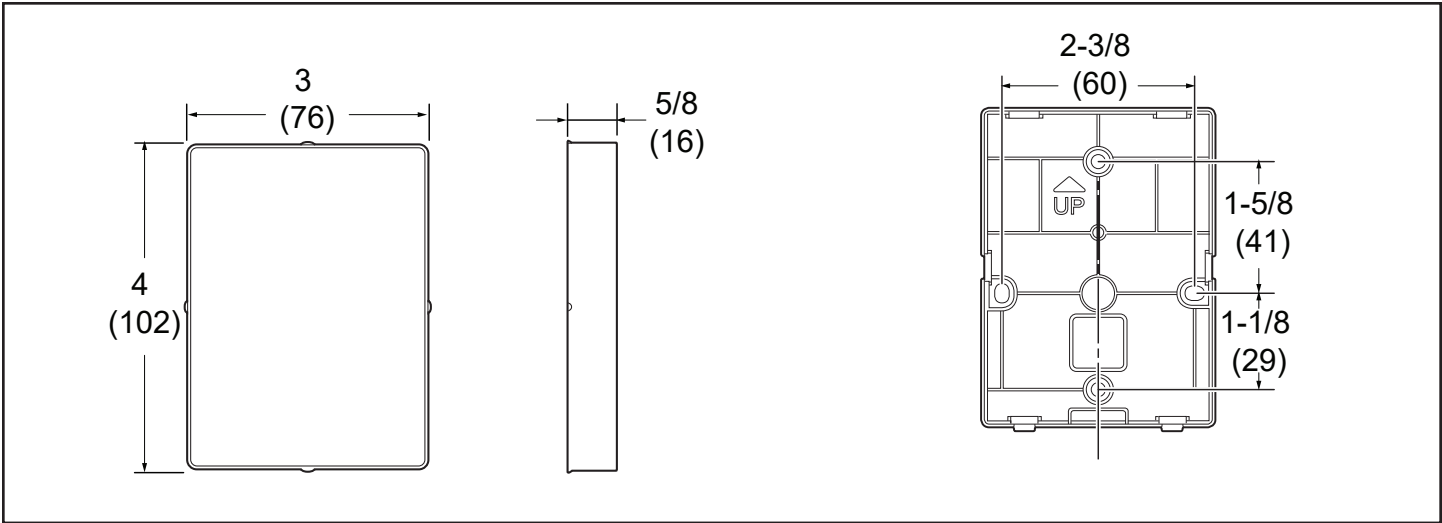

Figure 17. V0STAT55P-3 Dimensions

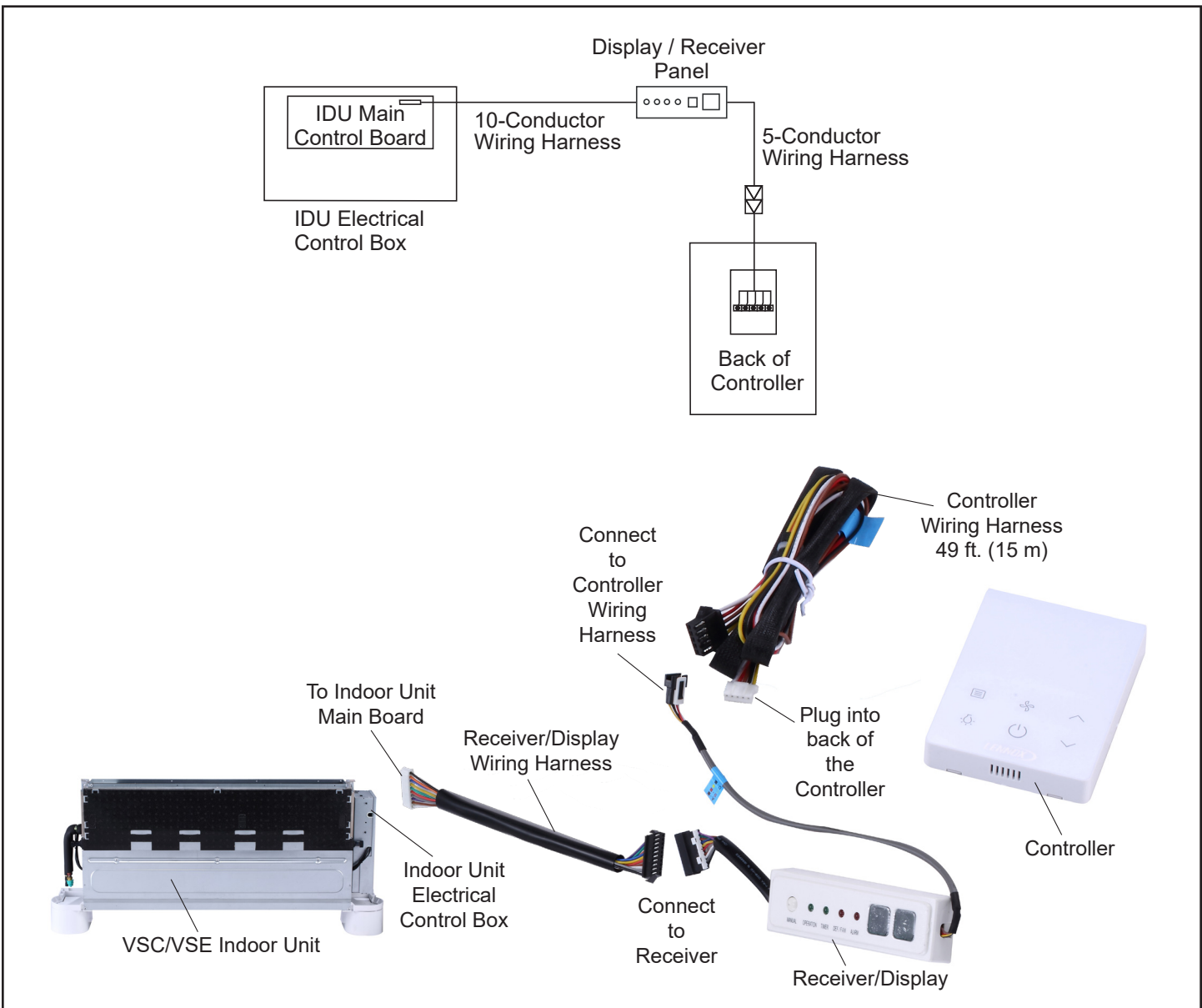

Figure 18. V0STAT55P-3 Schematic and Connection Diagram

## Controller Installation

The V0STAT55P-3 controller can be mounted inside of the VSC/VSE unit or on a wall.

## Operation

**NOTE** - Indoor units connected to a local controller may also be controlled by a centralized controller. Indoor units respond to the last command sent. It is recommended that indoor units be controlled from a single source of control, either local controller or centralized controller but not both, to avoid conflicts in commands.

After powering on the controller, wait 30 seconds for initialization. The indoor unit cannot be controlled by the controller until initialization is complete.

### Start/Stop Operation

Press the Power button.

- Controller ON: LED display lit.
- Controller OFF: LED display not lit.

### Set Operation Mode

Press the Mode button to scroll through the mode selections.

- Cool – System operates in cooling mode.
- Heat – System operates in heating mode.
- Dry -- System operates in dehumidification mode. **NOTE** - fan speed cannot be adjusted during dry mode.
- Auto -- System operates in auto mode.
- Fan – Fan only, no heating or cooling.

### To set (or change) the room temperature setting (set-point)

Press the up-arrow & down-arrow buttons to adjust the set-point.

When in Auto mode, separate heating and cooling setpoints can be set. Press the Mode button to switch between heating and cooling setpoints.

### Backlight

- The backlight turns on when the controller is powered on. The backlight automatically turns off after 4 seconds.
- Press the Backlight button to turn on the backlight. Press any button except for Backlight and Power to turn off the backlight.

### Temperature Unit Display

- Press the Mode button and the Down arrow button and hold for 3 seconds to toggle between Fahrenheit and Celsius temperature display.

## Spot Check Instructions

Use the Spot Check Performance table below and the Manual button on the unit Receiver/Display to view diagnostic information the indoor unit.

**Table 4. Spot Check Performance Identification Table**

No.	Content	Recorded Value/Date
0	Normal display	
1	Communication address of indoor unit	
2	Indoor unit capacity (horsepower)	
3	Network address of indoor unit	
4	The actual setpoint temperature	
5	The actual indoor temperature T1	
6	The middle coil temperature T2	
7	The coil inlet temperature T2A	
8	The coil outlet temperature T2B	
9	The actual superheat temperature	
10	The actual subcool temperature	
11	Error Code	
12	Indoor software version	
13	End (--)	

This Spot Check Performance table is located on the unit service panel.  
The diagnostic information can also be obtained using the wired remote controller.

## Troubleshooting

### Digital Display

The indoor unit is equipped with a receiver that has a digital display that provides an error code. Refer to the table to view the error codes. The error code will replace the temperature setting displayed on the receiver. If more than one error has occurred, the codes will alternate so that all codes are shown.

Make note of the code (E1, EE, etc.), then reset the display by pressing the ON/OFF button on the unit controller. Press the ON/OFF button a second time to reapply power to unit. If the code is still displayed, disconnect and restore power at the unit disconnect switch or circuit breaker. If the problem was temporary, the code will not reappear. If the error code reappears after power has been broken and restored at the disconnect switch or circuit breaker, call VRF Technical Support 1-844-438-8731.



Figure 19. Receiver/Display

Table 5. Fault Code Display on Indoor Unit Receiver

Error Code	Description
FE	No address
E0	Mode conflict
E1	Communication error between indoor and main outdoor unit
E2	T1 (Room temperature sensor) malfunction
E3	T2 (Middle of evaporator sensor) malfunction
E4	T2B (Outlet of evaporator sensor) malfunction
E5	T2A (Inlet of evaporator sensor) malfunction
E6	DC fan motor error
E7	EEPROM failure
Eb	EXV malfunction
Ed	Outdoor unit Fault
EE	High Water Alarm
A0	Emergency stop
D8	Remote off
U4	MS self-inspection error
F8	MS error

Table 6. Fault Code Display on Controller

Error Code	Description
F0	Communication/Address error between indoor units and wired controller
F1	Communication/Wiring error between indoor units and wired controller
E2	Controller temperature sensor error

**Technical Support**

1-844-GET-VRF1

(1-844-438-8731)

[vrftechsupport@lennoxind.com](mailto:vrftechsupport@lennoxind.com)

[www.LennoxVRF.com](http://www.LennoxVRF.com)

Download the app  
from the Apple App Store or the Google Play store.

