

**OUTDOOR COIL  
REPLACEMENT KIT**

**INSTALLATION INSTRUCTIONS FOR OUTDOOR COIL REPLACEMENT KIT (15D63; 616351-01)  
USED ON LGH/LCH/KG/KC PACKAGED ROOFTOP UNITS**

**Shipping and Packing List**

**Package 1 of 1 contains:**

- 1- End cap
- 4- Diagonal coil support rails
- 1- Coil top support
- 4- Middle channels
- 4- Coil edge protectors
- 1- Wall brace

**Bag assembly containing:**

- 12-Coil mounting brackets
- 12-Grommets
- 24-#10 Sheet metal screws
- 4-Hex flange screws

*Note - Four replacement coils are packaged separately from this kit.*

**Application**

This kit is used on LGH/LCH/KG/KC 210 and KG/KC 240S & 300S units equipped with three refrigerant circuits. Four coils replace two existing coils.

**⚠ WARNING**

**Improper installation, adjustment, alteration, service or maintenance can cause property damage, personal injury or loss of life. Installation and service must be performed by a licensed professional HVAC installer or equivalent, service agency, or the gas supplier**

**⚠ CAUTION**

**As with any mechanical equipment, contact with sharp sheet metal edges can result in personal injury. Take care while handling this equipment and wear gloves and protective clothing.**

**Remove Existing Coils**

It is recommended to remove the existing outdoor coils and move to an area on the ground where the replacement coils can be partially assembled.

- 1- Remove condenser access panel and condenser covers on the front and back side of unit. Remove plumbing cover. See figure 1.
- 2- Use an approved method to remove refrigerant from all three stages.

**⚠ IMPORTANT**

**The Clean Air Act of 1990 bans the intentional venting of refrigerant (CFC's and HCFC's) as of July 1, 1992. Approved methods of recovery, recycling or reclaiming must be followed. Fines and/or incarceration may be levied for non-compliance.**

- 3- Unbraid copper piping to coils.
- 4- Remove and retain two screws at the top and bottom of each diagonal coil support rail. See figure 2.
- 5- Slide coils out of unit from the back side.

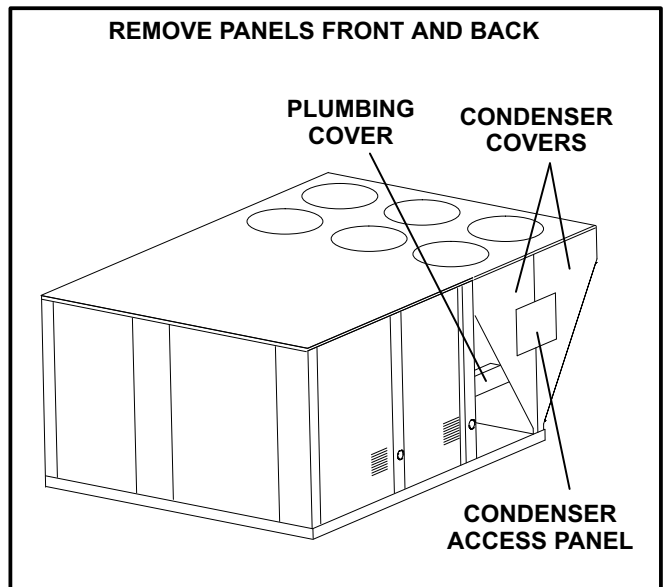

**FIGURE 1**

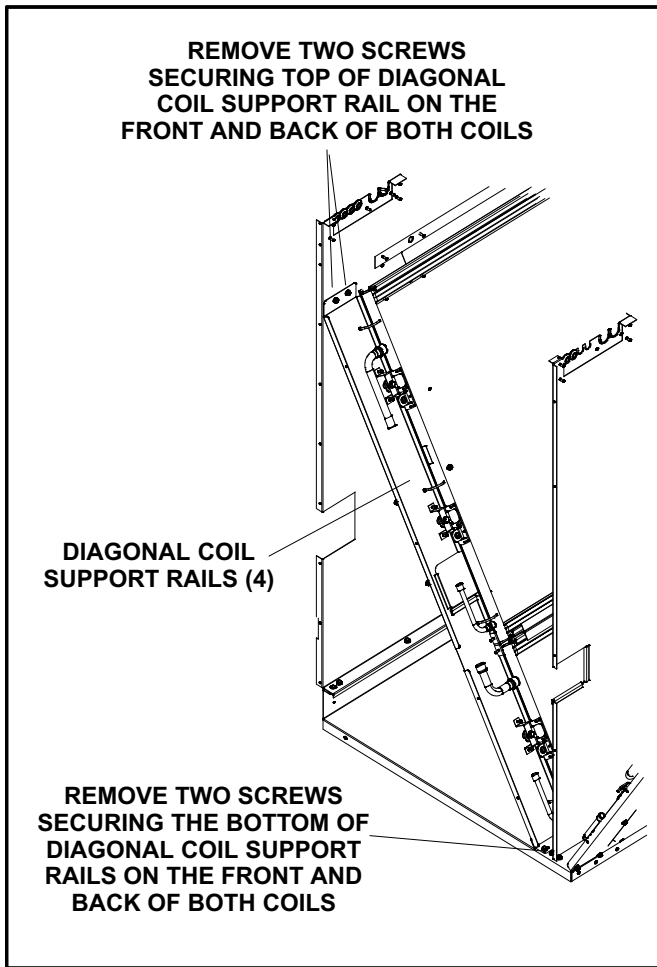

FIGURE 2

## Disassemble Outdoor Section

See figure 3.

- 1- Disconnect the wiring from all condenser fans.
- 2- Remove and discard the end cap, bottom coil channels, and brackets above coils.
- 3- Remove and reuse vertical, triangular, and rectangular condenser dividers, and the two condenser section top panels.

*Note - Lift edge of top panels and pivot where flanges overlap to remove.*

- 4- Remove and discard the wall brace secured to the panel between the compressor and condenser sections. See figure 3.

**PARTIALLY DISASSEMBLE OUTDOOR SECTION**

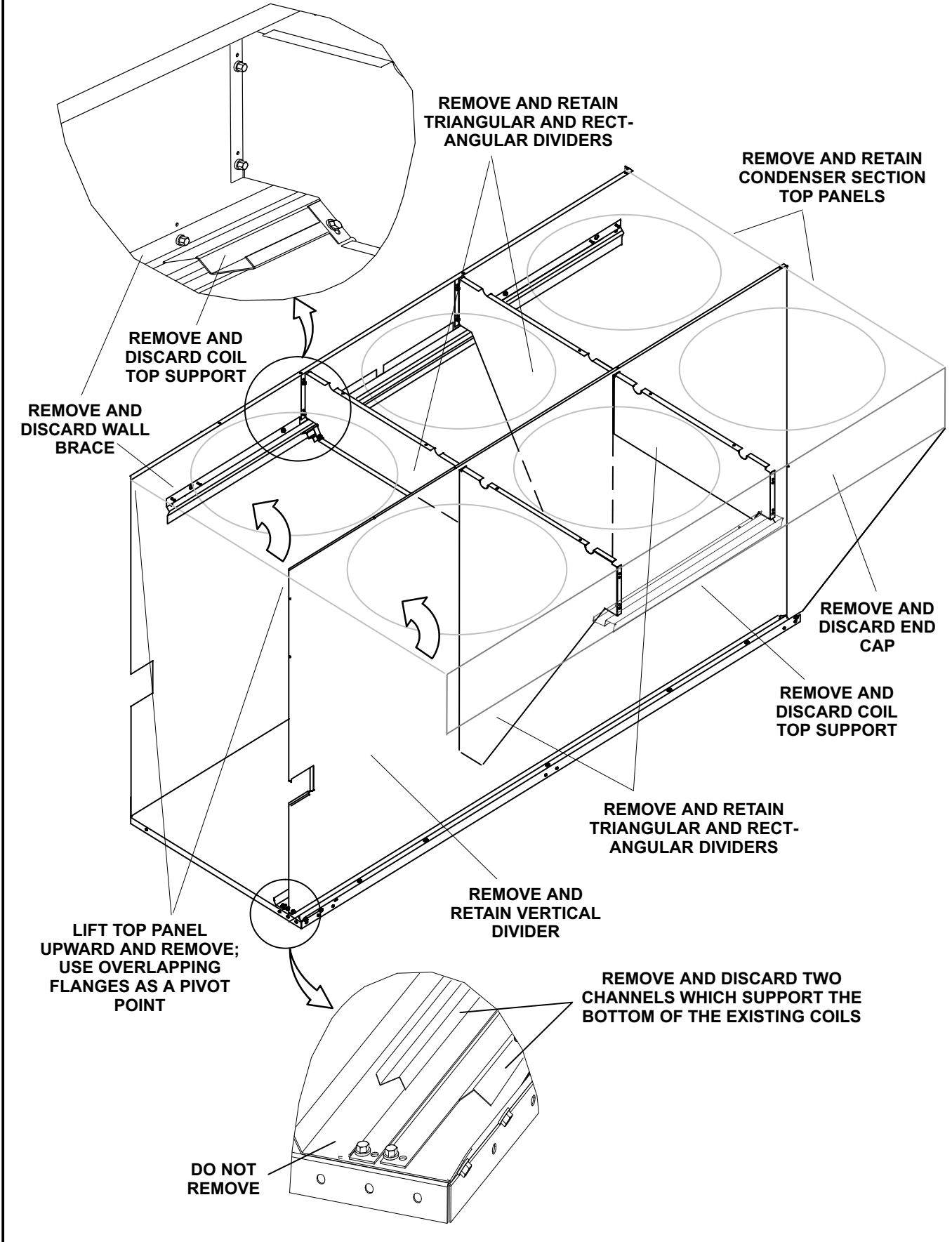

**FIGURE 3**

## Prepare Replacement Coils

Coil seals and protectors must be removed from the existing coil and reused on the replacement coils. It is recommended to move the existing outdoor coils to an area on the ground where the replacement coils can be partially assembled.

- 1- Remove hardware securing diagonal coil support rails to all eight coil mounting brackets. See figure 4.
- 2- Cut wire ties and remove and retain seals fitted on the existing diagonal coil support rail flanges. Discard diagonal support flanges.
- 3- Cut the retained seals to fit the replacement diagonal support flanges. Secure seals with new wire ties.
- 4- Remove and retain coil protectors from existing coil.
- 5- Fit the four retained coil protectors and the four coil protectors provided in kit on replacement coils.
- 6- Remove and retain the seals from all four sides of the rectangular plumbing opening in the front inner diagonal coil support rail. See figure 6.
- 7- Install all twelve kit grommets in the replacement coil manifold brackets. See figure 5.
- 8- Secure the middle channels to the diagonal support brackets to create an H-shaped frame. See figure 6.
- 9- Position coils in the middle channels on the H-shaped frame. Align holes in the coil manifold brackets between holes provided in the diagonal support for the coil mounting bracket. See figure 7.
- 10- Secure all twelve coil mounting brackets to the diagonal support rails. See figure 8.

- 11- Install the bolts securing the coil manifold bracket to the coil mounting brackets. Use eight retained bolts and four bolts provided in kit.

*IMPORTANT - The grommet must be installed between the coil mounting bracket and diagonal support to prevent corrosion.*

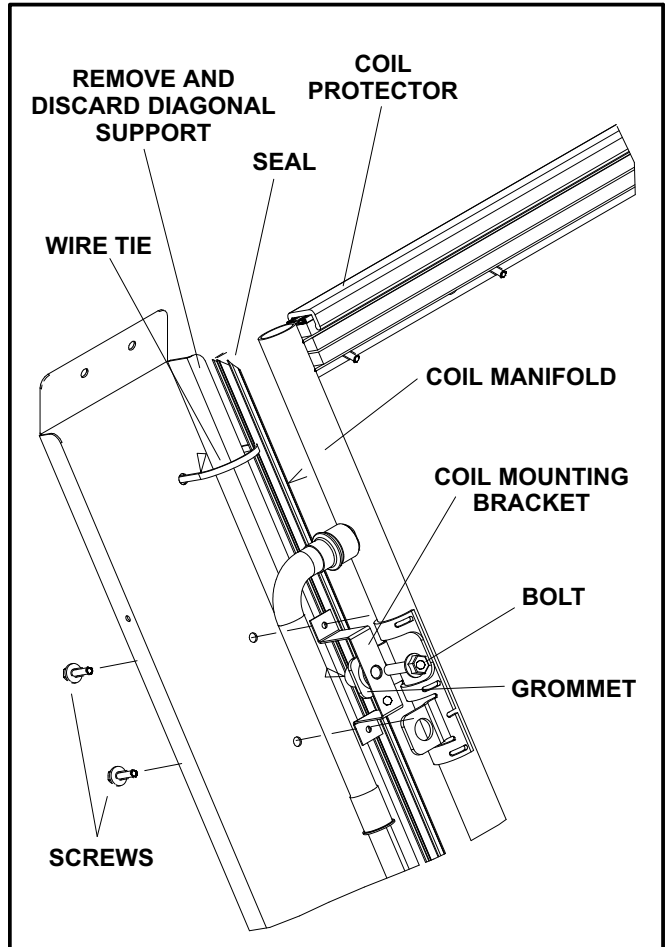

FIGURE 4

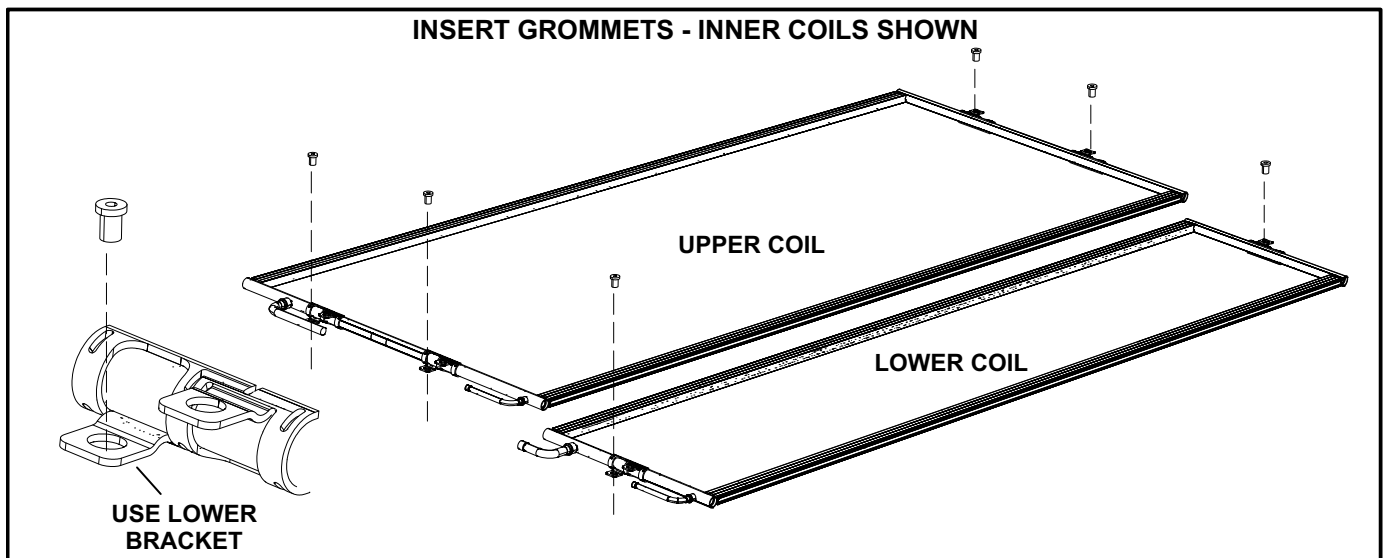

FIGURE 5

ASSEMBLE H-FRAME - INNER COIL SHOWN

DETAIL A

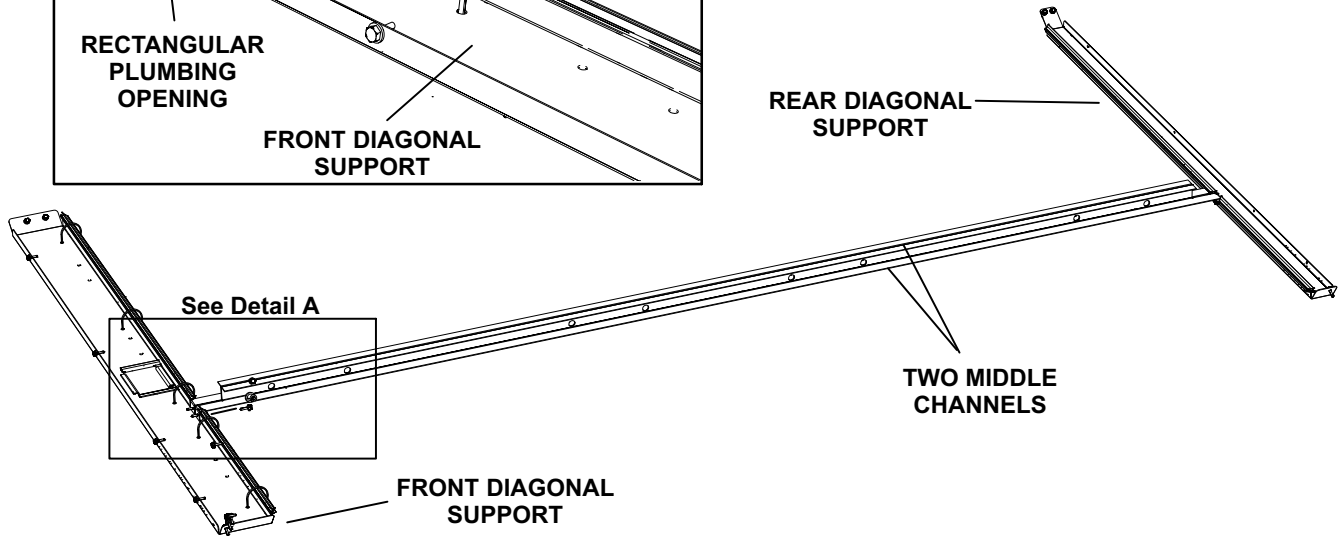
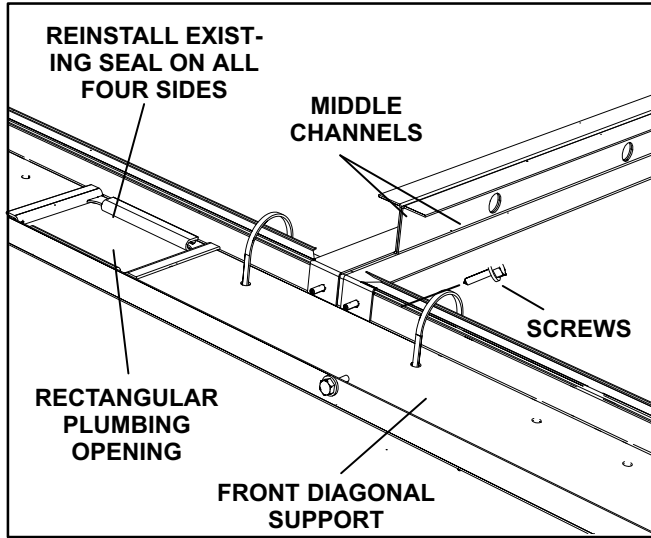

FIGURE 6

ALIGN COILS WITH H-FRAME

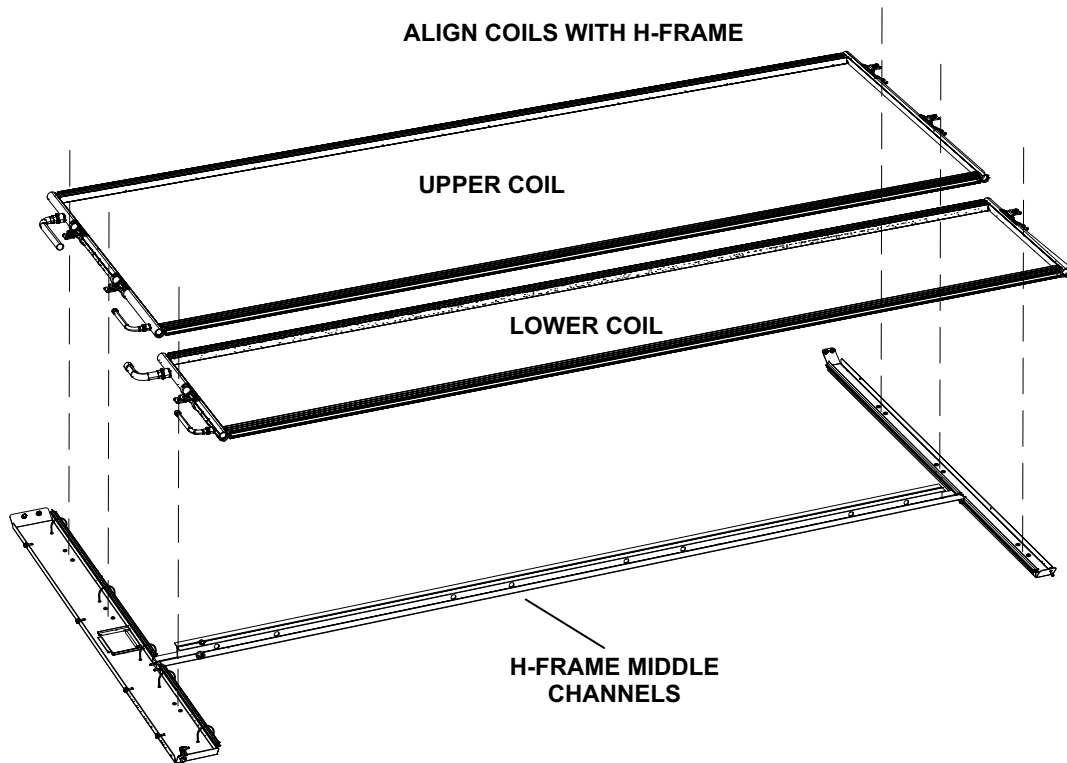
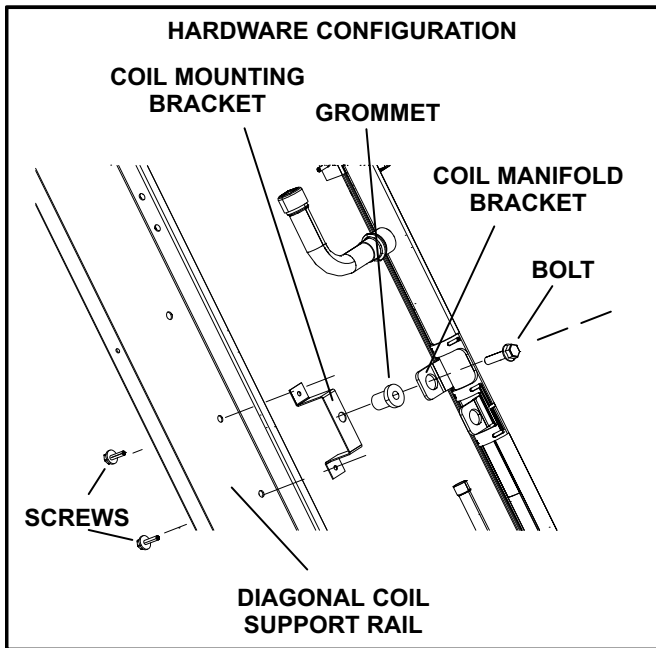
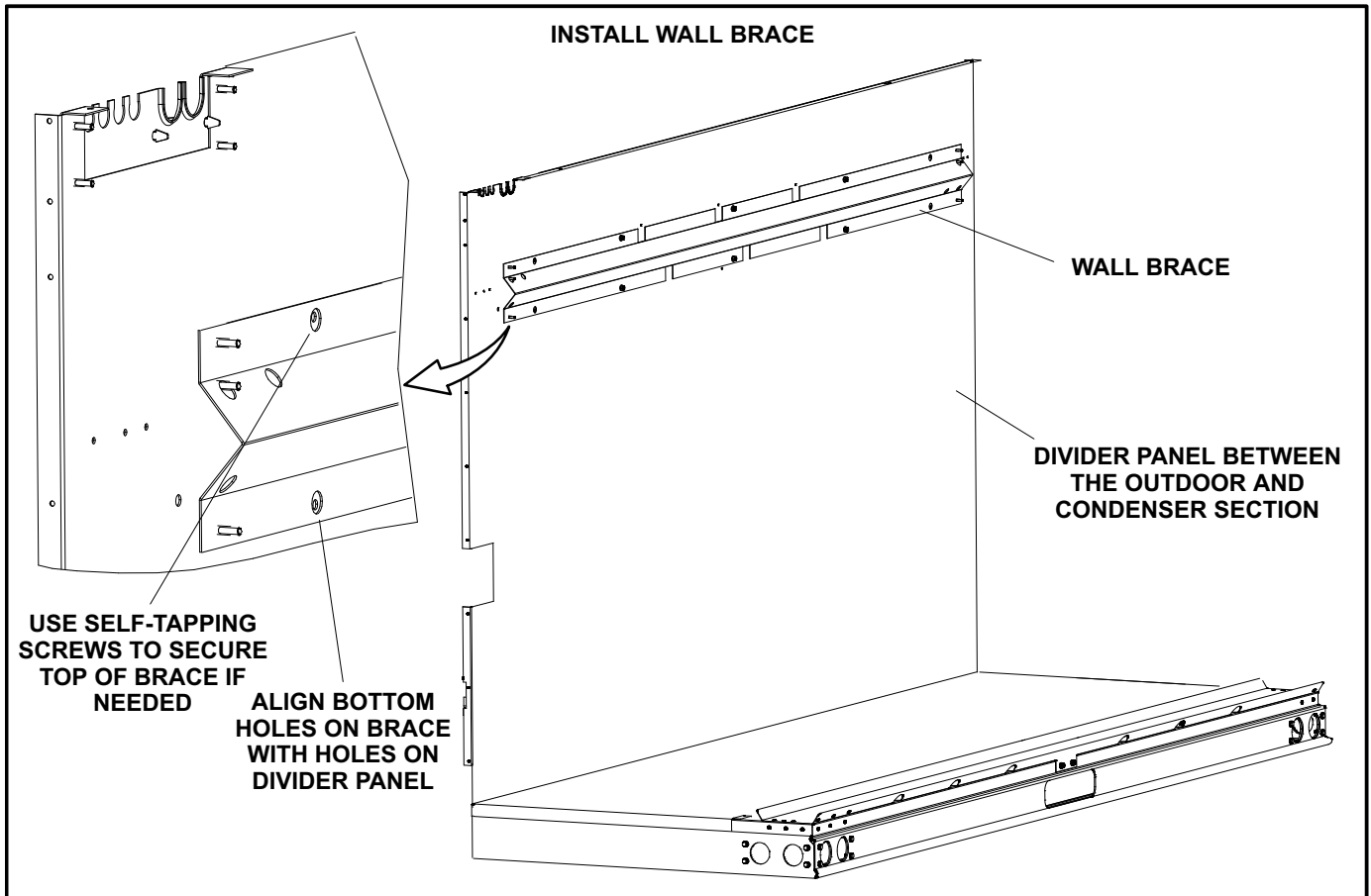

FIGURE 7



**Install Replacement Coils**

- 1- Secure the wall brace to the panel between the compressor and condenser sections. See figure 9.
- 2- Install the retained divider panels in the same manner they were removed.
- 3- Replace the condenser section top panels.
- 4- Install the top coil support, provided in kit, on to the outer triangular and rectangular panels. See figure 10.
- 5- Install the end cap, provided in kit, onto the outer top panel.
- 6- Install the coil assemblies into the unit. Secure the diagonal support brackets to the unit. See figure 11.
- 7- Braze plumbing in the same manner it was removed. Leak check all three systems.
- 8- Use an approved method to charge all three circuits with reclaimed refrigerant or amount of refrigerant listed on nameplate.
- 9- Replace access panels and plumbing cover.



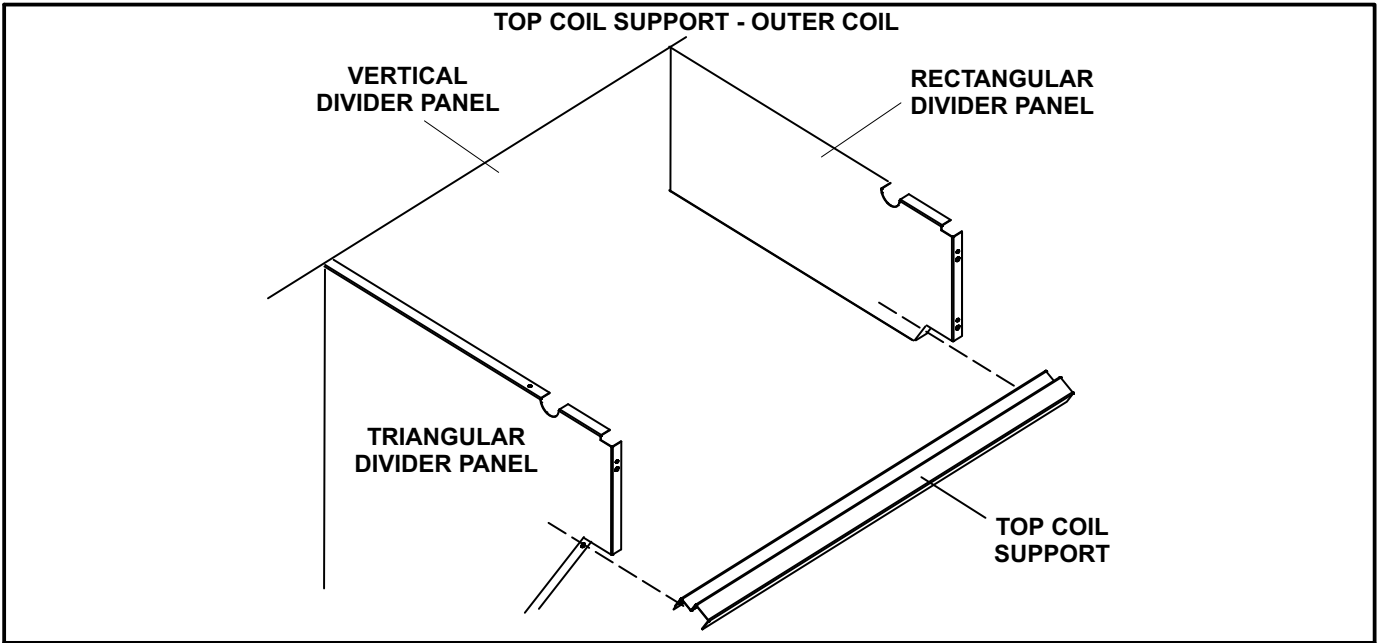

FIGURE 10

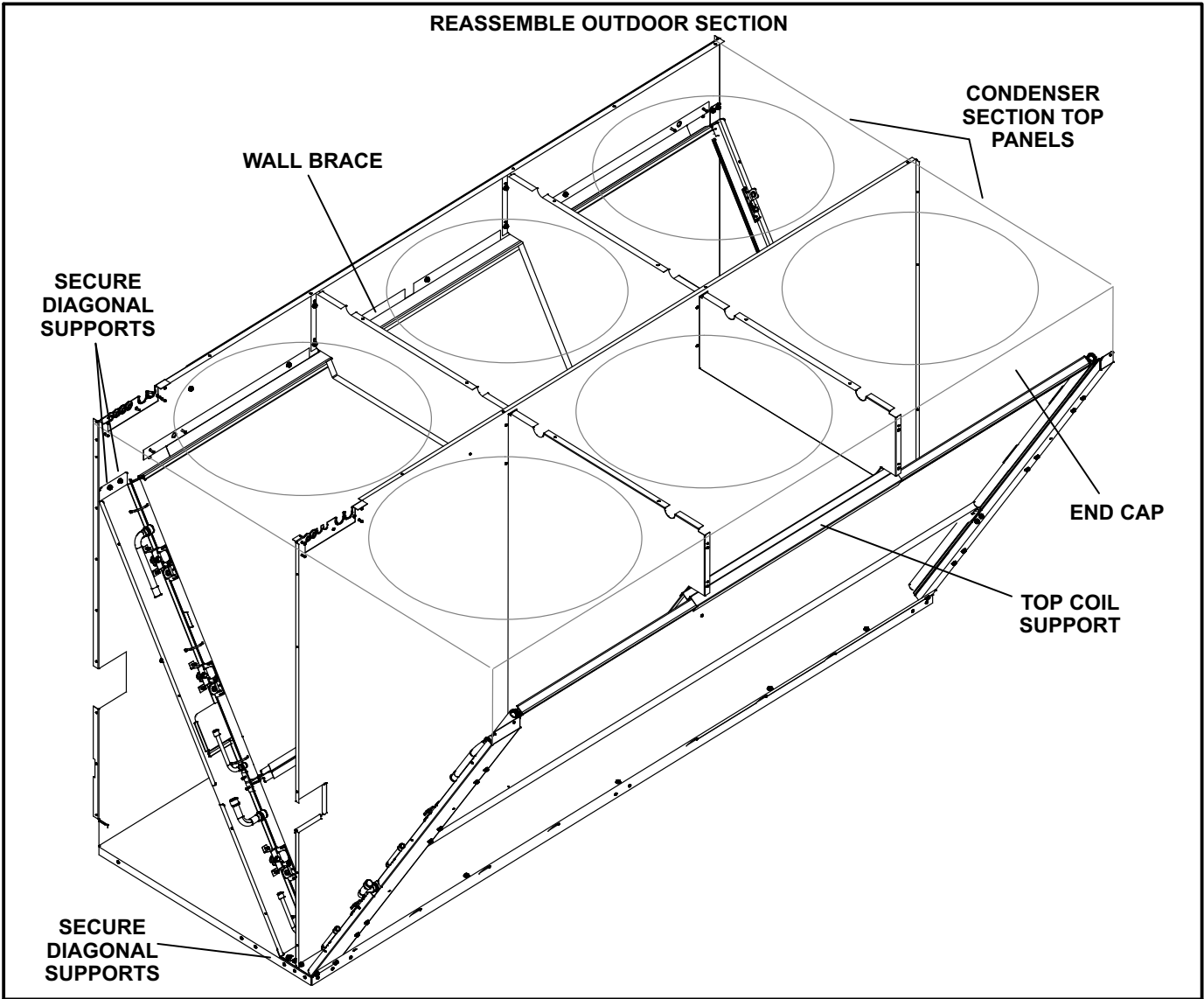

FIGURE 11