

KEY	DESCRIPTION
A55	CONTROL, BOARD LENNOX
A178	BOARD,COMPRESSORS 3 & 4
F3	FUSE, ELECTRIC HEAT
F4	FUSE, UNIT
F42	FUSE, ELECTRIC HEAT 1 A, 2A
F43	FUSE, ELECTRIC HEAT 3, 4
F44	FUSE, ELECTRIC HEAT 5, 6
F45	FUSE, ELECTRIC HEAT 7, 8
HE1	ELEMENT, ELECTRIC HEAT 1
HE3	ELEMENT, ELECTRIC HEAT 3
HE4	ELEMENT, ELECTRIC HEAT 4
HE5	ELEMENT, ELECTRIC HEAT 5
HE7	ELEMENT, ELECTRIC HEAT 7
HE8	ELEMENT, ELECTRIC HEAT 8
K9,-1	RELAY, HEAT
K15,-1	CONTACTOR, ELECTRIC HEAT 1,2
K16,-1	CONTACTOR, ELECTRIC HEAT 1A,2A
K17,-1	CONTACTOR, ELECTRIC HEAT 3,4
K18,-1	CONTACTOR, ELECTRIC HEAT 5,6

S15	SWITCH, LIMIT PRIMARY ELECTRIC HEAT
S20	SWITCH, LIMIT SECONDARY ELECTRIC HEAT 1,2
S107	SWITCH, PRIMARY ELECTRIC HEAT
S157	SWITCH, LIMIT SECONDARY ELECTRIC HEAT 1A
S158	SWITCH, LIMIT SECONDARY ELECTRIC HEAT 2A
S159	SWITCH, LIMIT SECONDARY ELECTRIC HEAT 3,4
S160	SWITCH, LIMIT SECONDARY ELECTRIC HEAT 5,6
TB2	TERMINAL STRIP, UNIT
TB3	TERMINAL STRIP, ELECTRIC HEAT

J/P	DESCRIPTION
7	ELECTRIC HEAT CONTROL
37	ELECTRIC HEAT CONTROL

DESIGNATION	VOLTAGE
G	460/60/3

- ⚠ NOT USED ON 15 AND 30KW UNITS
- ⚠ TB3 IS USED IN SOME UNITS
- ⚠ TB2, S48 OR CB10 MAY BE USED
- ⚠ REMOVE JUMPER PLUG WHEN FIELD INSTALLING ELECTRIC HEAT
- ⚠ F61 USED ON UNITS WITH SCCR OPTION
- ⚠ TB2 IS USED IN SOME SCCR OPTION UNITS ONLY

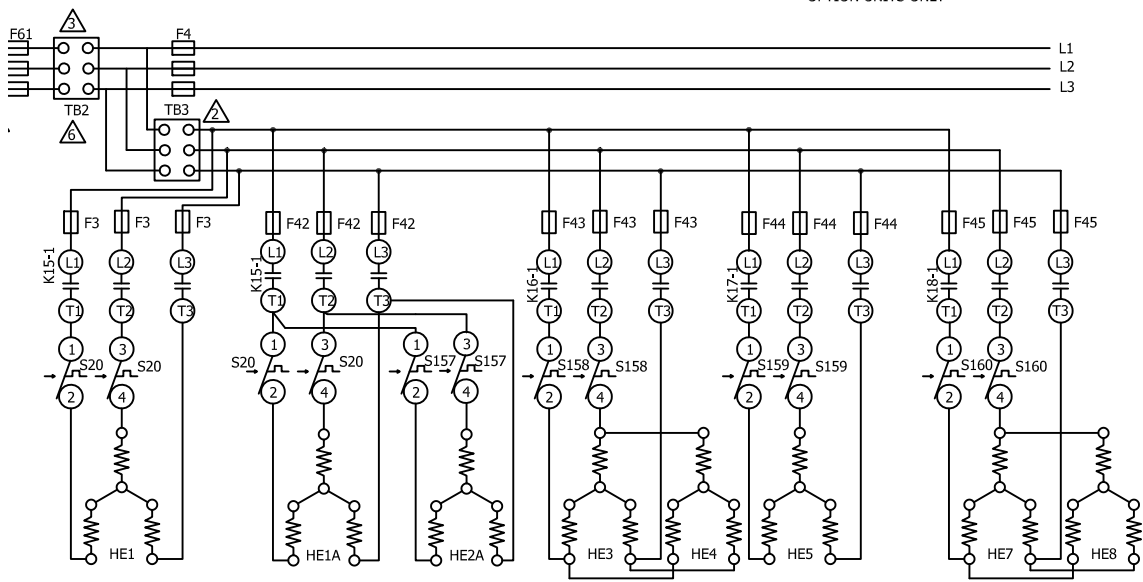

KW	HE1	HE1A	HE2A	HE3	HE4	HE5	HE7	HE8
15		7.5	7.5					
30		15	15					
45	15			7.5		15	7.5	
60	15			15		15	15	
90	15			15	15	15	15	15

← DENOTES OPTIONAL COMPONENTS

2021/09	WIRING DIAGRAM	9/21
	538126-02	
HEATING ELECTRIC HEAT E1EH,EHA-15,30,45,60,90 - G, J		
SECTION A		REV.0
Supersedes 538126-01	New Form No. 538126-02	